

HR



MOTORI ORBITALI

ORBITAL MOTORS

CARATTERISTICHE DEL MOTORE MOTOR FEATURES

HR

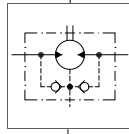

S

Versione Base
Standard Version

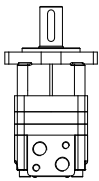

A4

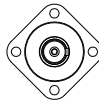

A2

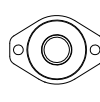

W

Versione Ruota
Wheel Version

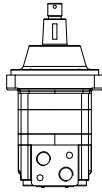

C4

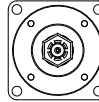

C

Versione Corta
Bearingless Version

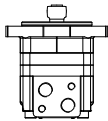

B4

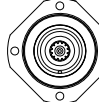

F

Versione Freno
Brake Version

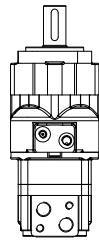

A4

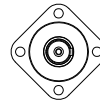

L

Versione Freno-Ruota
Wheel Version with brake

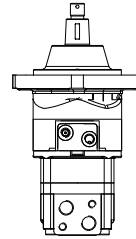

C4

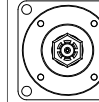

M

Versione corta per riduttore
Short Version for Gear Box

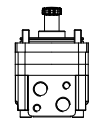

M4

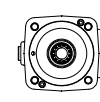

Albero supportato da due robusti cuscinetti a rulli conici che assicurano una grande tenuta ai carichi radiali (Max 40000 N).

Shaft supported by two heavy duty tapered roller bearings that ensure outstanding radial load capacity Max 40000 N [Max. 9000 lbf].

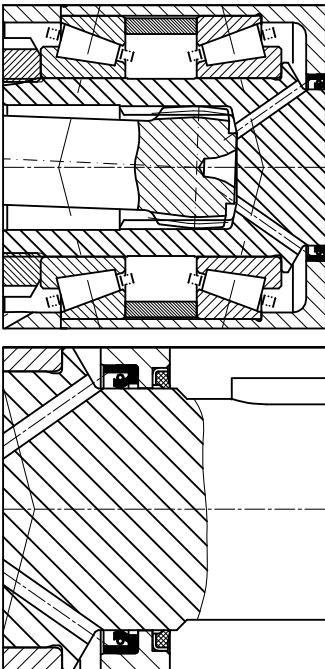

Guarnizione dell'albero in uscita ad alta pressione. Il motore è in grado di lavorare con pressioni in carcassa fino a 160 bar.

Dust Seal for high pressure of the output shaft. The motor can work with casing pressure up to 160 bar [2320 psi].

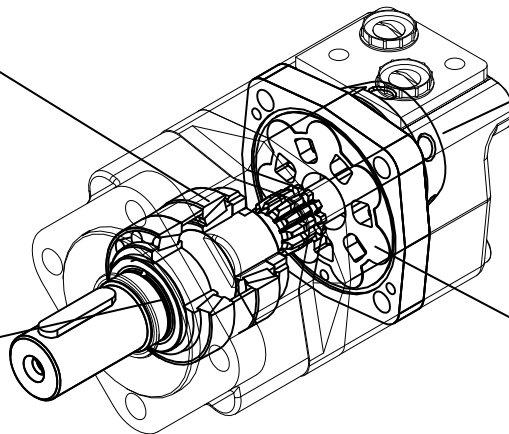

Distribuzione con valvola a disco con recupero automatico dei giochi effettuato dal fluido in pressione; viene così raggiunto un livello più basso di drenaggio ed un rendimento più elevato. Il motore è provvisto di valvole di drenaggio interne.

Disc valve distribution with automatic compensation of backlash done by fluid under pressure: lower drain figures are then guaranteed together with high efficiency. The motor is supplied with internally built-in check valves.

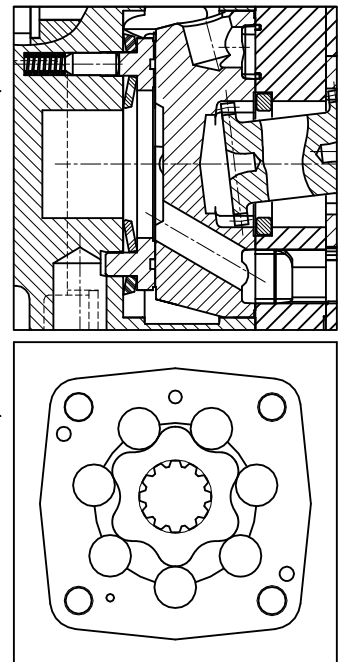

Organo motore roller che consente elevate pressioni di esercizio e lunga durata.

Heavy duty, roller type stator meant to work at high pressure and to guarantee extra long lasting.

CARATTERISTICHE TECNICHE TECHNICAL SPECIFICATIONS

Motore Motor	Cilindrata Displacement cm ³ /giro [in ³ /rev]	Max. pressione in ingresso Max. input pressure bar [psi]		Pressione diff. max. Max. differential pressure bar [psi]		Coppia max.* Max. torque*		Portata max. Max. flow		Velocità max. Max. speed		Potenza max. Max. power	
		Cont	Int ¹⁾	Cont	Int ¹⁾	Cont	Int ¹⁾	Cont	Int ¹⁾	Cont	Int ¹⁾	Cont	Int ¹⁾
HR 080	80.4 [4.9]	Cont Int ¹⁾ Peak ²⁾	210 [3045] 310 [4495] 310 [4495]	Cont Int ¹⁾ Peak ²⁾	205 [2972] 310 [4495] 310 [4495]	Cont Int ¹⁾	235 [173] 345 [254]	Cont Int ¹⁾	75 [19.8] 80 [21.1]	Cont Int ¹⁾	932 995	Cont Int ¹⁾	23 [30.8] 36 [48.2]
HR 100	100 [6.1]	Cont Int ¹⁾ Peak ²⁾	210 [3045] 310 [4495] 310 [4495]	Cont Int ¹⁾ Peak ²⁾	205 [2972] 310 [4495] 310 [4495]	Cont Int ¹⁾	295 [217] 445 [328]	Cont Int ¹⁾	75 [19.8] 95 [25]	Cont Int ¹⁾	750 950	Cont Int ¹⁾	23.1 [30.9] 44.2 [59.2]
HR 130	125.7 [7.66]	Cont Int ¹⁾ Peak ²⁾	210 [3045] 310 [4495] 310 [4495]	Cont Int ¹⁾ Peak ²⁾	205 [2972] 310 [4495] 310 [4495]	Cont Int ¹⁾	375 [276] 545 [401]	Cont Int ¹⁾	75 [19.8] 95 [25]	Cont Int ¹⁾	596 755	Cont Int ¹⁾	23.4 [31.3] 43.1 [57.7]
HR 160	160 [9.76]	Cont Int ¹⁾ Peak ²⁾	210 [3045] 310 [4495] 310 [4495]	Cont Int ¹⁾ Peak ²⁾	205 [2972] 260 [3770] 310 [4495]	Cont Int ¹⁾	465 [342] 570 [420]	Cont Int ¹⁾	75 [19.8] 95 [25]	Cont Int ¹⁾	468 593	Cont Int ¹⁾	18.2 [24.3] 22.5 [30.1]
HR 200	200 [12.2]	Cont Int ¹⁾ Peak ²⁾	210 [3045] 310 [4495] 310 [4495]	Cont Int ¹⁾ Peak ²⁾	205 [2972] 260 [3770] 310 [4495]	Cont Int ¹⁾	580 [427] 670 [494]	Cont Int ¹⁾	75 [19.8] 95 [25]	Cont Int ¹⁾	375 475	Cont Int ¹⁾	15.2 [20.3] 22.5 [30.1]
HR 250	250 [15.25]	Cont Int ¹⁾ Peak ²⁾	210 [3045] 310 [4495] 310 [4495]	Cont Int ¹⁾ Peak ²⁾	205 [2972] 260 [3770] 310 [4495]	Cont Int ¹⁾	710 [523] 820 [604]	Cont Int ¹⁾	75 [19.8] 95 [25]	Cont Int ¹⁾	300 380	Cont Int ¹⁾	14.2 [19] 19.5 [26.1]
HR 315	314.5 [19.18]	Cont Int ¹⁾ Peak ²⁾	210 [3045] 310 [4495] 310 [4495]	Cont Int ¹⁾ Peak ²⁾	205 [2972] 240 [3480] 310 [4495]	Cont Int ¹⁾	885 [652] 960 [707]	Cont Int ¹⁾	75 [19.8] 95 [25]	Cont Int ¹⁾	238 302	Cont Int ¹⁾	11 [14.7] 19.5 [26.1]
HR 400	393 [23.97]	Cont Int ¹⁾ Peak ²⁾	210 [3045] 310 [4495] 310 [4495]	Cont Int ¹⁾ Peak ²⁾	155 [2247] 190 [2755] 225 [3250]	Cont Int ¹⁾	860 [633] 980 [722]	Cont Int ¹⁾	75 [19.8] 95 [25]	Cont Int ¹⁾	190 241	Cont Int ¹⁾	11 [14.7] 13 [17.4]

		HR 080	HR 100	HR 130	HR 160	HR 200	HR 250	HR 315	HR 400
Pressione max avviamento a vuoto Max starting pressure with no load	bar [psi]	11 [159]	10 [145]	10 [145]	8 [116]	8 [116]	8 [116]	8 [116]	8 [116]
Coppia min. di spunto (A press. diff. max) Min. starting torque (At. Max Δp)	Nm [lbf·ft]	Cont. 180 [133] Int. 270 [199]	Cont. 230 [169] Int. 340 [250]	Cont. 300 [221] Int. 420 [309]	Cont. 370 [272] Int. 440 [324]	Cont. 465 [343] Int. 522 [385]	Cont. 568 [419] Int. 640 [472]	Cont. 700 [516] Int. 760 [560]	Cont. 680 [501] Int. 775 [571]

¹⁾ Le condizioni intermittenti non devono durare più del 10% di ogni minuto.
Intermittent duty must not exceed 10% each minute.

²⁾ Le condizioni di picco non devono durare più del 1% di ogni minuto.
Peak duty must not exceed 1% each minute.

* Per i motori con gli alberi riportati nella tabella sottostante la coppia massima ammissibile è:

* For motors with the shafts in the table below the Max. admissible torque is reduced as follows:

* Coppia max. ammissibile per tipo d'albero * Max. admissible torque for shaft type	Nm [lbf·ft]	ALBERO CILINDRICO CL254 CL254 CYLINDRICAL SHAFT	ALBERO SCANALATO SE250 SE250 SPLINED SHAFT
		Cont	300 [221]
Int ¹⁾	410 [302]	450 [332]	

¹⁾ Le condizioni intermittenti non devono durare più del 10% di ogni minuto.
Intermittent duty must not exceed 10% each minute.

MASSIMA PRESSIONE AMMESSA SULLA GUARNIZIONE ALBERO MAX PERMISSIBLE SHAFT SEAL PRESSURE

Pressione massima di scarico senza drenaggio o massima pressione nella linea di drenaggio.
Per condizioni di pressione e velocità non contemplate dal presente grafico si consiglia di contattare la S.A.M. Hydraulik.

Max. return pressure without drain line or max. pressure in the drain line.
For pressure and speeds not showed in the curve below, please contact S.A.M. Hydraulik.

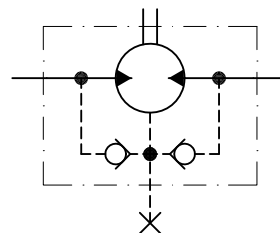
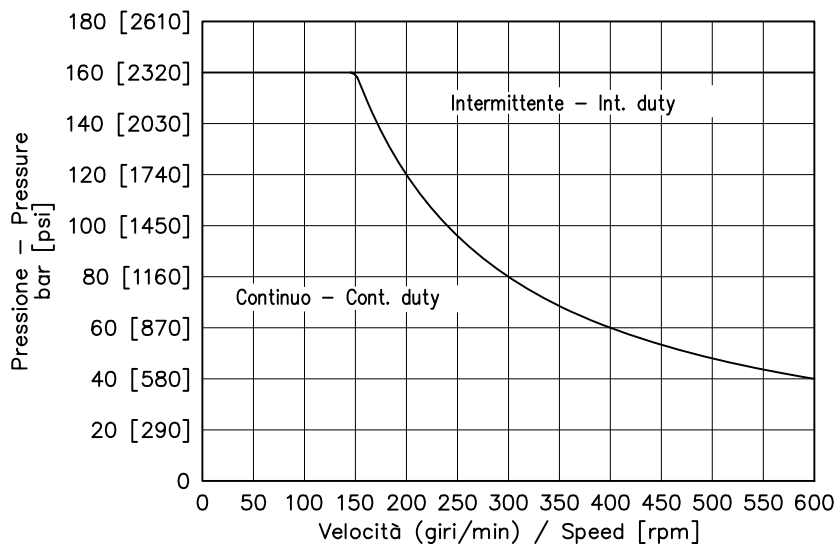

PERDITE DI CARICO PER ATTRAVERSAMENTO PRESSURE LOSS

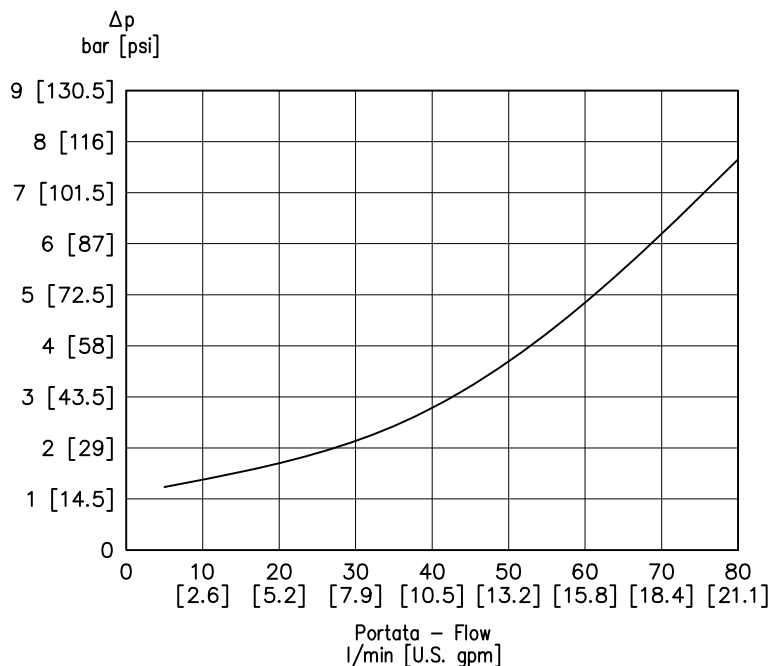

Il diagramma è stato ottenuto con prove eseguite su un numero significativo di motori, utilizzando un olio avente una viscosità cinematica di 37 cSt alla temperatura di 45 C°.

Diagram according to tests done with a relevant number of motors and using hydraulic oil with cinematic viscosity of 37 cSt at 45° temperature.

CODICI DI ORDINAZIONE ORDERING CODES

Le seguenti lettere o numeri del codice, sono state sviluppate per identificare tutte le configurazioni possibili dei motori HR. Usare il seguente modulo per identificare le caratteristiche desiderate. **Tutte le lettere o numeri del codice devono comparire in fase d'ordine.** Si consiglia di leggere attentamente il catalogo prima di iniziare la compilazione del codice di ordinazione.

The following alphanumeric digits system has been developed to identify all of the configuration options for the HR motors. Use the model code below to specify the desired features. **All alphanumeric digits system of the code must be present when ordering.** We recommend to carefully read the catalogue before filling the ordering code.

CODICE PRODOTTO / MODEL CODE

1	2	2A	3	4	5	6	7	8	8A	9	10

1 - SERIE / SERIES

HR	Motore orbitale Orbital motor
----	----------------------------------

2 - VERSIONI / VERSIONS

S	Versione Base Standard Version	STANDARD
W	Versione Ruota Wheel Version	
C	Versione Corta Bearingless Version	
F	Versione Freno Brake Version	
L	Versione Freno-Ruota Wheel Version with brake	
M	Versione corta per riduttore Short Bearingless Version for Gear Box	

2A - CARATTERISTICA VERSIONE / VERSION FEATURE

		VERSIONI / VERSIONS					
		S	W	C	M	F	L
XX	Versione base Standard version	•	•	•	/	•	•
OK	Doppio attacco drenaggio 1/4 G (BSPP) (lato mandata) Double drain port 1/4 G (BSPP) (at delivery side)	•	•	• ⁽¹⁾	/	/	/
SK	Doppio attacco drenaggio 7/16" - 20UNF (lato mandata) Double drain port 7/16" - 20UNF (at delivery side)	•	•	• ⁽¹⁾	/	/	/
LW	Bassi trafileamenti Low leakage	•	•	•	•	•	•
SW	Doppio attacco drenaggio 7/16" - 20UNF (lato mandata) + Bassi trafileamenti Double drain port 7/16" - 20UNF (at delivery side) + Low leakage	•	•	• ⁽¹⁾	/	/	/
KW	Doppio attacco drenaggio 1/4 G (BSPP) (lato mandata) + Bassi trafileamenti Double drain port 1/4 G (BSPP) (at delivery side) + Low leakage	•	•	• ⁽¹⁾	/	/	/
03	Versione per Riduttore Brevini SDU31 + Bassi trafileamenti Brevini SDU31 gear box Version + Low leakage	/	/	/	•	/	/
04	Versione 12 Molle / 10 Contatti (disponibile con cilindrata 100 e 315) 12 Springs / 10 Contacts Version (available with displacement 100 and 315)	/	/	/	/	•	•
05	Versione 8 Molle (disponibile con cilindrata 250 - 315 - 400) 8 Springs Version (available with displacement 250 - 315 - 400)	/	/	/	/	•	•
06	Versione Coppia maggiorata (disponibile con cilindrata 200-250) Increased braking torque Version (available with displacement 200-250)	/	/	/	/	•	•
08	Bassi trafileamenti + Versione 8 Molle (disponibile con cilindrata 250 - 315 - 400) Low leakage + 8 Springs Version (available with displacement 250 - 315 - 400)	/	/	/	/	•	•
09	Versione Coppia maggiorata (disponibile con cilindrata 200-250) + Bassi trafileamenti Increased braking torque Version (available with displacement 200-250) + Low leakage	/	/	/	/	•	•
10	Corpo freno attacchi SAE Brake housing SAE ports	/	/	/	/	•	•

• Disponibile - Available / Non Disponibile - Not Available

(1) Montaggio come da documento M-052611. Si prega di contattare Samhydraulik per ulteriori informazioni.
Assembly as the M-052611 document. Please contact Samhydraulik for further information.

1	2	2A	3	4	5	6	7	8	8A	9	10

3 - CILINDRATA / DISPLACEMENT

080	80.4 cm ³ /giro [4.9 in ³ /rev]
100	100 cm ³ /giro [6.1 in ³ /rev]
130	125.7 cm ³ /giro [7.66 in ³ /rev]
160	160 cm ³ /giro [9.7 in ³ /rev]
200	200 cm ³ /giro [12.2 in ³ /rev]
250	250 cm ³ /giro [15.2 in ³ /rev]
315	314.5 cm ³ /giro [19.18 in ³ /rev]
400	393 cm ³ /giro [23.97 in ³ /rev]

4 - FLANGIA / FLANGE

		VERSIONI / VERSIONS					
		S	W	C	M	F	L
M4	Flangia corta per riduttore Short flange for Gear Box	/	/	/	●	/	/
A4	4 Fori (Ø 82.5 mm) 4 Bolt [Ø 3.248 in]	●	/	/	/	●	/
A2	SAE A 2 Fori SAE A 2 Bolt	●	/	/	/	○	/
B4	ISO 4 Fori (Ø 100 mm) ISO 4 Bolt [Ø 3.937 in]	/	/	●	/	/	/
C4	ISO 4 Fori (Ø 125 mm) ISO 4 Bolt [Ø 4.921 in]	/	●	/	/	/	●

● Disponibile - Available / Non Disponibile - Not Available ○ A Richiesta - Upon Request

5 - ATTACCHI / MAIN PORTS

			VERSIONI / VERSIONS					
			S	W	C	M	F	L
M09	Attacchi 1/2 G BSPP (32x22) 1/2 G BSPP (32x22) Main Ports	STANDARD	●	●	●	●	●	●
S09	Attacchi 7/8" - 14 UNF (32x22) 7/8" - 14 UNF (32x22) Main Ports		●	●	●	/	●	●
L09	Attacchi Laterali 1" 1/16 - 12 UN 1" 1/16 - 12 UN (Main Ports Positioned 180° apart)		●	●	●	/	●	●
F09	Attacchi Frontali 1" 1/16 - 12 UN 1" 1/16 - 12 UN (End Main Ports)		●	●	●	/	●	●
R09	Attacchi Frontali 7/8" - 14 UNF 7/8" - 14 UNF (End Main Ports)	A Richiesta Upon Request	●	●	●	●	●	●

● Disponibile - Available / Non Disponibile - Not Available

Per le dimensioni vedere Pag. F/17
For the dimensions see Pag. F/17

1	2	2A	3	4	5	6	7	8	8A	9	10

6 - ESTREMITÀ ALBERO / SHAFT END

		VERSIONI / VERSIONS					
		S	W	C	M	F	L
DB001	Semigiunto Z=12 12/24 DP Dog Bone T=12 12/24 DP	/	/	•	•	/	/
CL254	Albero Cilindrico Ø25.4 mm 1 in Parallel keyed	•	/	/	/	/	/
C3175	Albero Cilindrico Ø31.75 mm 1.25 in Parallel keyed	•	/	/	/	/	/
CL320	Albero Cilindrico Ø32 mm 1.259 in Parallel keyed	•	•	/	/	•	•
CN320	Albero Conico Tapered Shaft	•	•	/	/	•	•
SE250	Albero Scanalato (profilo SAE 6B 1" Z6) Splined Shaft (SAE 6B 1" 6T spline)	•	/	/	/	/	/
SC320	Albero Scanalato (profilo ASA Z14 12/24) - Versione Europea Splined Shaft (ASA 14T 12/24 spline) - Europe Version	•	•	/	/	/	/
SE320	Albero Scanalato (profilo ASA Z14 12/24) - Versione Americana Splined Shaft (ASA 14T 12/24 spline) - USA Version	•	/	/	/	/	/
SE350	Albero Scanalato (P.t.o. DIN 9611 Form1) Splined Shaft (P.t.o. DIN 9611 Form1)	•	/	/	/	/	/

• Disponibile - Available / Non Disponibile - Not Available

Per le dimensioni vedere Pag. F/16
For the dimensions see Pag. F/16

7 - TENUTE / SEALS

N	NBR	STANDARD
V	FKM	

8 - VALVOLE / VALVES

		ATTACCHI / MAIN PORTS				
		M09	S09	L09	F09	R09
XXXX	Non Richieste Not Required	•	•	•	•	•
M091	Valvola di massima pressione VAF 09 - D Pressure relief valve VAF 09 - D	•	/	/	/	/
M092	Valvola Antiurto e Anticavitazione VAAF 09 / 40 Anticavitation and Anti-Shock Valve VAAF 09 / 40	•	/	/	/	/
M093	Valvola bilanciata di blocco e controllo discesa VCD1 09 - S/AF Overcentre Valve with VCD1 09 - S/AF	•	/	/	/	/
M094	Valvola di controllo bilanciata a doppio effetto VCR1 09 - D/AF Double-acting overcentre valve with shuttle valve VCR1 09 - D/AF	•	/	/	/	/
M095	Valvola di controllo bilanciata a doppio effetto con valvola limitatrice di pressione VCR1 09 D/AF LDP Double-acting overcentre valve with shuttle valve VCR1 09 D/AF LDP	•	/	/	/	/
M096	Valvola Regolatrice di Portata VRP 09 Flow Control Valve VRP 09	•	/	/	/	/
M097	Valvola di massima pressione VAF 09 - D/AF Pressure relief valve VAF 09 - D/AF	•	/	/	/	/

• Disponibile - Available / Non Disponibile - Not Available

Per le caratteristiche vedere il catalogo valvole
For the feature see catalogue valves

1	2	2A	3	4	5	6	7	8	8A	9	10

8A - CARATTERISTICA VALVOLA / VALVES FEATURE

		VALVOLE / VALVES							
		XXXX	M091	M092	M093	M094	M095	M096	M097
000	Caratteristica non necessaria Feature not necessary	•	/	/	/	/	/	/	/
001	Non Tarata (Campo Taratura 50÷100 bar) Not Set [725 to 1450 psi]	/	•	/	/	/	/	/	/
002	Non Tarata (Campo Taratura 50÷210 bar) Not Set [725 to 3045 psi]	/	/	•	/	/	/	/	/
003	Non Tarata (Campo Taratura 30÷220 bar) Not Set [435 to 3190 psi]	/	/	/	/	•	/	/	/
004	Non Tarata (Campo Taratura 30÷220 bar) Not Set [435 to 3190 psi]	/	/	/	/	/	•	/	/
005	Non Tarata (Pressione massima 315 bar) Not Set [Max pressure 4567 psi]	/	/	/	/	/	/	•	/
006	Non Tarata (Campo Taratura 100÷200 bar) Not Set [1450 to 2900 psi]	/	•	/	/	/	/	/	/
007	Non Tarata (Campo Taratura 100÷280 bar) Not Set [1450 to 4060 psi]	/	/	/	/	/	/	/	•
700	Rapporto di Pilotaggio 7:1 Pilot Ratio 7:1	/	/	/	•	/	/	/	/
300	Rapporto di Pilotaggio 3:1 Pilot Ratio 3:1	/	/	/	•	/	/	/	/

• Disponibile - Available / Non Disponibile - Not Available

Per la fornitura di valvole tarate contattare Uff. Tecnico.

Please contact Technical department for valve which require specific setting

9 - VALVOLE DI LAVAGGIO(*) / FLUSHING VALVES(*)

		ATTACCHI / MAIN PORTS				
		M09	S09	L09	F09	R09
XX	Non Richieste Not Required	•	•	•	•	•
06	Valvola di lavaggio VSC/F - 6 l/min VSC/F Flushing valve - [1.58 U.S. gpm]	•	•	/	/	/
09	Valvola di lavaggio VSC/F - 10.5 l/min VSC/F Flushing valve - [2.77 U.S. gpm]	•	•	/	/	/
15	Valvola di lavaggio VSC/F - 15 l/min VSC/F Flushing valve - [3.96 U.S. gpm]	•	•	/	/	/
21	Valvola di lavaggio VSC/F - 20 l/min VSC/F Flushing valve - [5.28 U.S. gpm]	•	•	/	/	/

• Disponibile - Available / Non Disponibile - Not Available

(*) E' possibile abbinare le valvole di lavaggio solo con la valvola VAF 09 - D
(*) It is possible to combine the flushing valves only with VAF 09 - D valve.

Per le caratteristiche vedere il catalogo valvole
For the feature see catalogue valves

10 - OPZIONI / OPTIONS

XX	Non verniciato Not painted
01	Verniciato Nero RAL 9005 Black Painted RAL 9005
02	Verniciato Blu RAL 5015 Blue Painted RAL 5015
03	Rotazione Invertita Reverse Rotation
A1	Rotazione Invertita + Verniciato Nero RAL 9005 Reverse Rotation + Black Painted RAL 9005

DIMENSIONI E PESI DIMENSIONS AND WEIGHT

VERSIONE BASE - "S" "S" - STANDARD VERSION

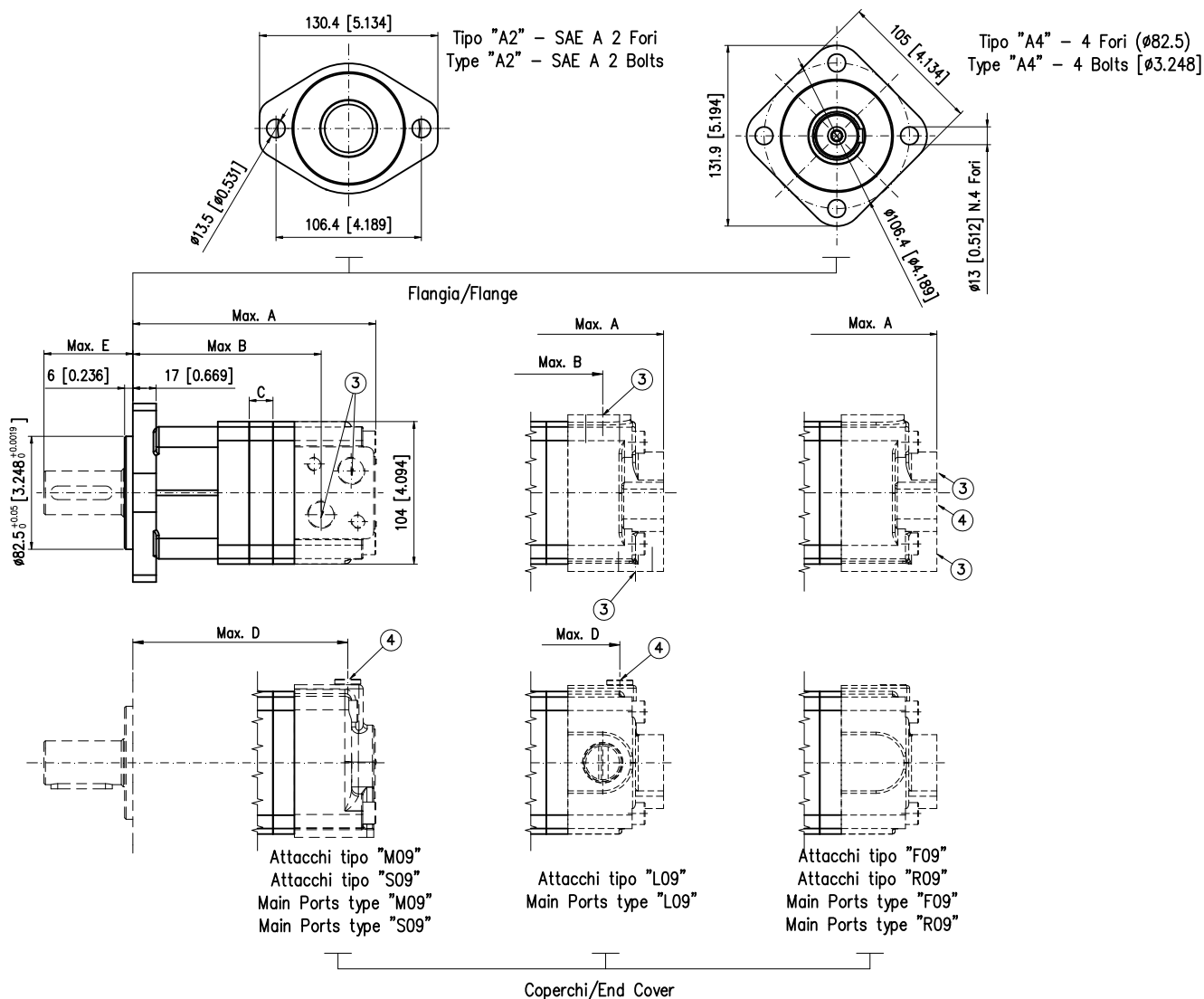

- 3) Fori Alimentazione
Main ports
- 4) Drenaggi motore
Drain port

*Per le dimensioni di alberi e attacchi vedere da pag. F/16 a pag. F/18
*For shafts and main ports dimension see from pag. F/16 to pag. F/18

	Attacchi Tipo "M09" - Main Ports type "M09" Attacchi Tipo "S09" - Main Ports type "S09"							
Cil. (cm ³ /giro)	080	100	130	160	200	250	315	400
Displ. [in ³ /rev]	[4.8]	[6.1]	[7.9]	[9.7]	[12.2]	[15.2]	[19.2]	[24.4]
A mm	174.5	177.5	182	188	195	203.5	215	228.5
A [in]	[6.87]	[6.98]	[7.16]	[7.40]	[7.67]	[8.01]	[8.46]	[8.99]
B mm	134	137.5	142	148	155	164	175	188.5
B [in]	[5.27]	[5.41]	[5.59]	[5.82]	[6.10]	[6.45]	[6.88]	[7.42]
C mm	14	17.4	21.8	27.8	34.8	43.5	54.8	68.4
C [in]	[0.551]	[0.68]	[0.85]	[1.09]	[1.37]	[1.71]	[2.15]	[2.69]
D mm	154	157	161	167.5	174.5	183.5	194.5	208
D [in]	[6.06]	[6.18]	[6.33]	[6.59]	[6.87]	[7.22]	[7.65]	[8.18]
Pesi kg	10.5	10.7	11	11.4	11.8	12.4	13.1	14
Weight [lb]	[23.1]	[23.6]	[24.5]	[25.1]	[26]	[27.3]	[28.8]	[30.8]

	Attacchi Tipo "L09" - Main Ports type "L09" Attacchi Tipo "F09" - Main Ports type "F09" Attacchi Tipo "R09" - Main Ports type "R09"							
Cil. (cm ³ /giro)	080	100	130	160	200	250	315	400
Displ. [in ³ /rev]	[4.8]	[6.1]	[7.9]	[9.7]	[12.2]	[15.2]	[19.2]	[24.4]
A mm	185	188	192.5	198.5	205.5	214	225.5	239
A [in]	[7.28]	[7.40]	[7.57]	[7.81]	[8.09]	[8.42]	[8.87]	[9.40]
B mm	140	143.5	148	154	161	170	181	194.5
B [in]	[5.51]	[5.64]	[5.82]	[6.06]	[6.33]	[6.69]	[7.12]	[7.65]
C mm	14	17.4	21.8	27.8	34.8	43.5	54.8	68.4
C [in]	[0.551]	[0.68]	[0.85]	[1.09]	[1.37]	[1.71]	[2.15]	[2.69]
D mm	153	156	160	166.5	173.5	182.5	193.5	207
D [in]	[6.02]	[6.14]	[6.29]	[6.55]	[6.83]	[7.18]	[7.61]	[8.14]
Pesi kg	10.5	10.7	11	11.4	11.8	12.4	13.1	14
Weight [lb]	[23.1]	[23.6]	[24.5]	[25.1]	[26]	[27.3]	[28.8]	[30.8]

ALBERO SHAFT	CL320	C3175	CL254	CN320	SE250	SE320	SC320	SE350
E (mm)	65	56	51	65.9	51	55.9	65	110
E [in]	[2.55]	[2.20]	[2.00]	[2.59]	[2.00]	[2.20]	[2.55]	[4.29]

VERSIONE RUOTA - "W"
"W" - WHEEL VERSION

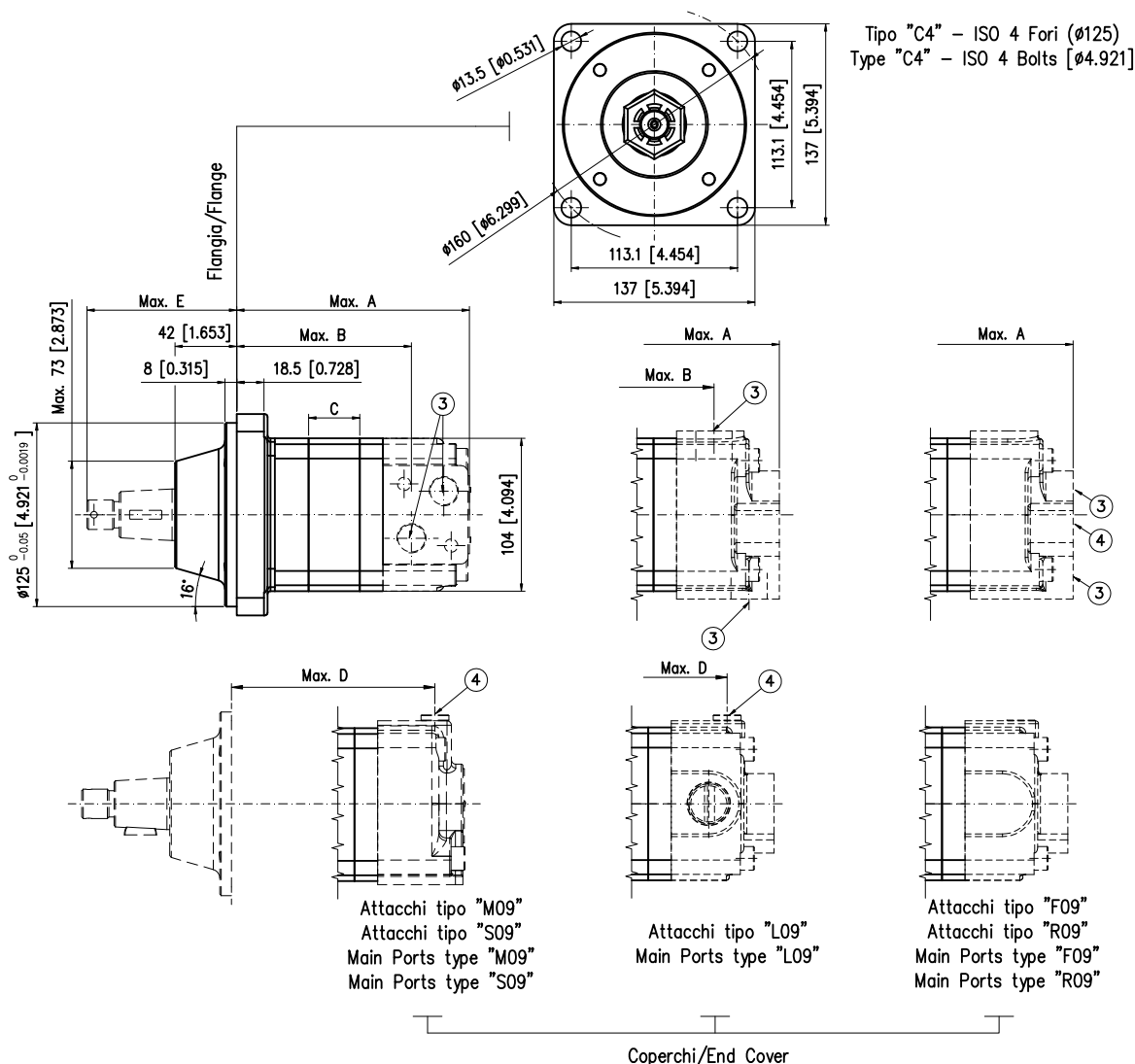

Tipo "C4" - ISO 4 Fori (Ø125)
 Type "C4" - ISO 4 Bolts [Ø4.921]

- 3) Fori Alimentazione
 Main ports
- 4) Drenaggi motore
 Drain port

*Per le dimensioni di alberi e attacchi vedere da pag. F/16 a pag. F/18
 *For shafts and main ports dimension see from pag. F/16 to pag. F/18

Attacchi Tipo "M09" - Main Ports type "M09"								
Attacchi Tipo "S09" - Main Ports type "S09"								
Cil. (cm ³ /giro)	080	100	130	160	200	250	315	400
Displ. [in ³ /rev]	[4.8]	[6.1]	[7.9]	[9.7]	[12.2]	[15.2]	[19.2]	[24.4]
A mm	136.5	140	144.5	150.5	157.5	166	177.5	191
A [in]	[5.37]	[5.51]	[5.68]	[5.92]	[6.20]	[6.53]	[6.98]	[7.51]
B mm	97.5	101	105.3	111.3	118.3	127	138.5	152
B [in]	[3.83]	[3.97]	[4.14]	[4.38]	[4.65]	[5.00]	[5.45]	[5.98]
C mm	14	17.4	21.8	27.8	34.8	43.5	54.8	68.4
C [in]	[0.551]	[0.68]	[0.85]	[1.09]	[1.37]	[1.71]	[2.15]	[2.69]
D mm	117	120.5	124.8	130.8	137.8	146.5	158	171.5
D [in]	[4.60]	[4.74]	[4.91]	[5.14]	[5.42]	[5.76]	[6.22]	[6.75]
Pesi kg	10.9	11.1	11.5	11.8	12.2	12.9	13.6	14.4
Weight [lb]	[24]	[24.4]	[25.3]	[26]	[26.8]	[28.4]	[29.9]	[31.7]

Attacchi Tipo "L09" - Main Ports type "L09"								
Attacchi Tipo "F09" - Main Ports type "F09"								
Attacchi Tipo "R09" - Main Ports type "R09"								
Cil. (cm ³ /giro)	080	100	130	160	200	250	315	400
Displ. [in ³ /rev]	[4.8]	[6.1]	[7.9]	[9.7]	[12.2]	[15.2]	[19.2]	[24.4]
A mm	149.5	153	157.5	163.5	170.5	179	190.5	204
A [in]	[5.88]	[6.02]	[6.20]	[6.43]	[6.71]	[7.04]	[7.50]	[8.03]
B mm	103.5	107	111.3	117.3	124.3	133	144.5	158
B [in]	[4.07]	[4.21]	[4.38]	[4.61]	[4.89]	[5.23]	[5.68]	[6.22]
C (mm)	14	17.4	21.8	27.8	34.8	43.5	54.8	68.4
C [in]	[0.551]	[0.68]	[0.85]	[1.09]	[1.37]	[1.71]	[2.15]	[2.69]
D (mm)	114.5	118	122.3	128.3	135.5	144	155.5	169
D [in]	[4.50]	[4.64]	[4.81]	[5.05]	[5.33]	[5.66]	[6.12]	[6.65]
Pesi (kg)	10.9	11.1	11.5	11.8	12.2	12.9	13.6	14.4
Weight (lb)	[24]	[24.4]	[25.3]	[26]	[26.8]	[28.4]	[29.9]	[31.7]

ALBERO SHAFT	CL320	CN320	SC320
E mm	101	102	101
E [in]	[3.97]	[4.01]	[3.97]

VERSIONE FRENO - "F"
"F" - BRAKE VERSION

Tipo "A2" - SAE A 2 Fori
 Type "A2" - SAE A 2 Bolts

Tipo "A4" - 4 Fori (Ø82.5)
 Type "A4" - 4 Bolts [Ø3.248]

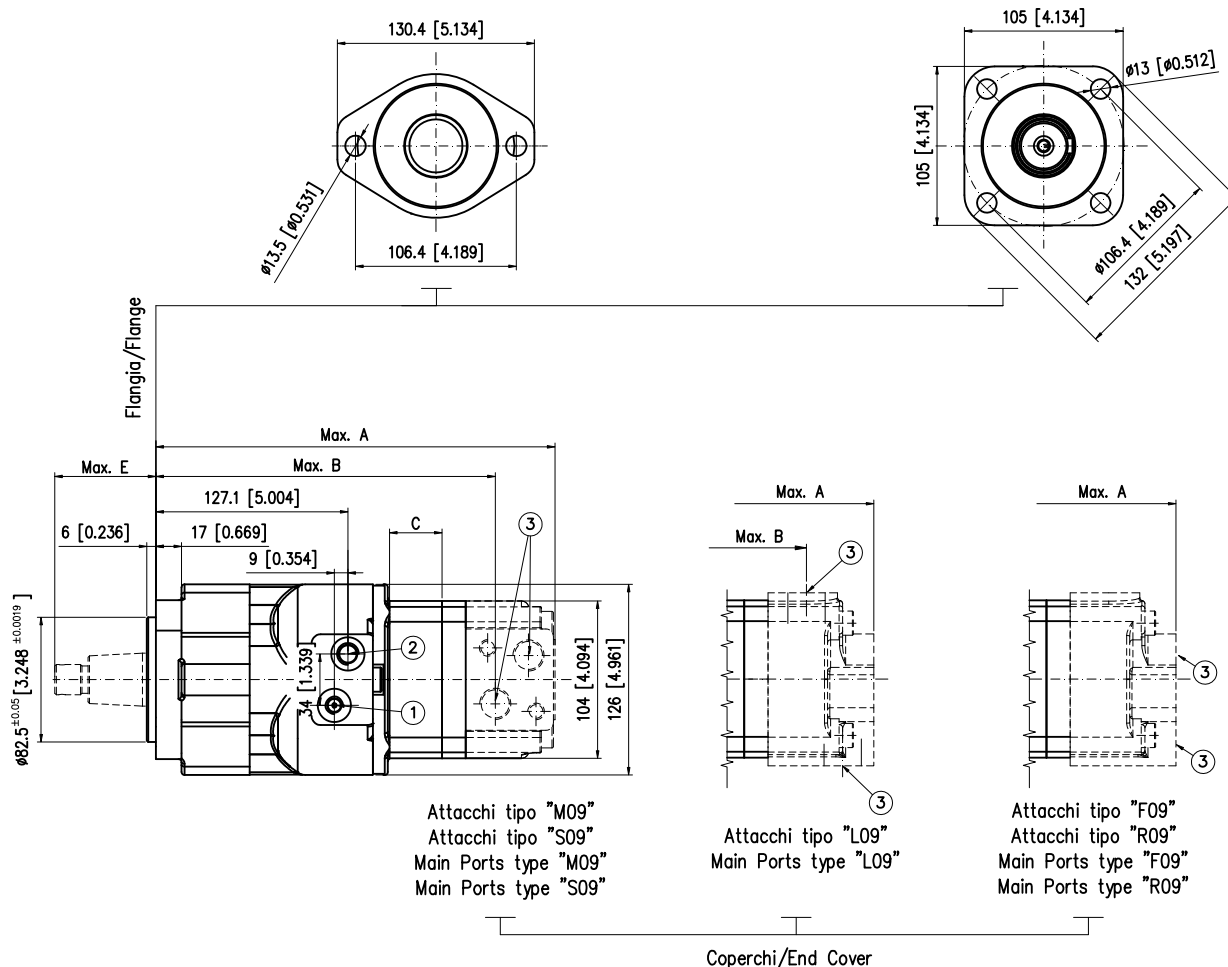

- 1) Comando apertura freno 1/8 G (BSPP) Prof.fil. 11mm (ISO)
 1/8 G (BSPP) Brake releasing plug, thread depth [0.42 in] (ISO)
 Comando apertura freno 7/16" - 20 UNF Prof.fil. 11mm (SAE)
 7/16" - 20 UNF Brake releasing plug, thread depth [0.42 in] (SAE)
- 2) Drenaggio Motore 1/4 G (BSPP) Prof.fil. 11mm (ISO)
 1/4 G (BSPP) Drain port, thread depth [0.42 in] (ISO)
 Drenaggio Motore 7/16" - 20 UNF Prof.fil. 11mm (SAE)
 7/16" - 20 UNF Drain port, thread depth [0.42 in] (SAE)
- 3) Fori Alimentazione
 Main ports

*Per le dimensioni di alberi e attacchi vedere da pag. F/16 a pag. F/18
 *For shafts and main ports dimension see from pag. F/16 to pag. F/18
 ** Per caratteristiche freno vedere pag. F/20
 ** For brake feature see pag. F/20

Attacchi Tipo "M09" - Main Ports type "M09"								
Attacchi Tipo "S09" - Main Ports type "S09"								
Cil. (cm ³ /giro)	080	100	130	160	200	250	315	400
Displ. [in ³ /rev]	[4.8]	[6.1]	[7.9]	[9.7]	[12.2]	[15.2]	[19.2]	[24.4]
A mm	243.3	246.7	251.1	257.1	264.1	272.8	284.1	297.7
A [in]	[9.57]	[9.71]	[9.88]	[10.12]	[10.39]	[10.74]	[11.18]	[11.72]
B mm	203.8	207.2	211.6	217.6	224.6	233.3	244.6	258.2
B [in]	[8.02]	[8.15]	[8.33]	[8.56]	[8.84]	[9.18]	[9.62]	[10.16]
C mm	14	17.4	21.8	27.8	34.8	43.5	54.8	68.4
C [in]	[0.551]	[0.68]	[0.85]	[1.09]	[1.37]	[1.71]	[2.15]	[2.69]
Pesi kg	17.3	17.5	17.9	18.2	18.6	19.3	20	20.8
Weight [lb]	[38.1]	[38.5]	[39.4]	[40.1]	[40.9]	[42.5]	[44]	[45.8]

Attacchi Tipo "L09" - Main Ports type "L09"								
Attacchi Tipo "F09" - Main Ports type "F09"								
Attacchi Tipo "R09" - Main Ports type "R09"								
Cil. (cm ³ /giro)	080	100	130	160	200	250	315	400
Displ. [in ³ /rev]	[4.8]	[6.1]	[7.9]	[9.7]	[12.2]	[15.2]	[19.2]	[24.4]
A mm	254.3	257.7	262.1	268.1	275.1	283.8	295.1	308.7
A [in]	[10.01]	[10.14]	[10.31]	[10.55]	[10.83]	[11.17]	[11.61]	[12.15]
B mm	209.8	213.2	217.6	223.6	230.6	239.3	250.6	264.2
B [in]	[8.25]	[8.39]	[8.56]	[8.80]	[9.07]	[9.42]	[9.86]	[10.40]
C mm	14	17.4	21.8	27.8	34.8	43.5	54.8	68.4
C [in]	[0.551]	[0.68]	[0.85]	[1.09]	[1.37]	[1.71]	[2.15]	[2.69]
Pesi kg	17.3	17.5	17.9	18.2	18.6	19.3	20	20.8
Weight [lb]	[38.1]	[38.5]	[39.4]	[40.1]	[40.9]	[42.5]	[44]	[45.8]

ALBERO SHAFT	CL320	CN320
E mm	65	65.9
E [in]	[2.55]	[2.59]

VERSIONE FRENO RUOTA - "L"
"L" - WHEEL WITH BRAKE VERSION

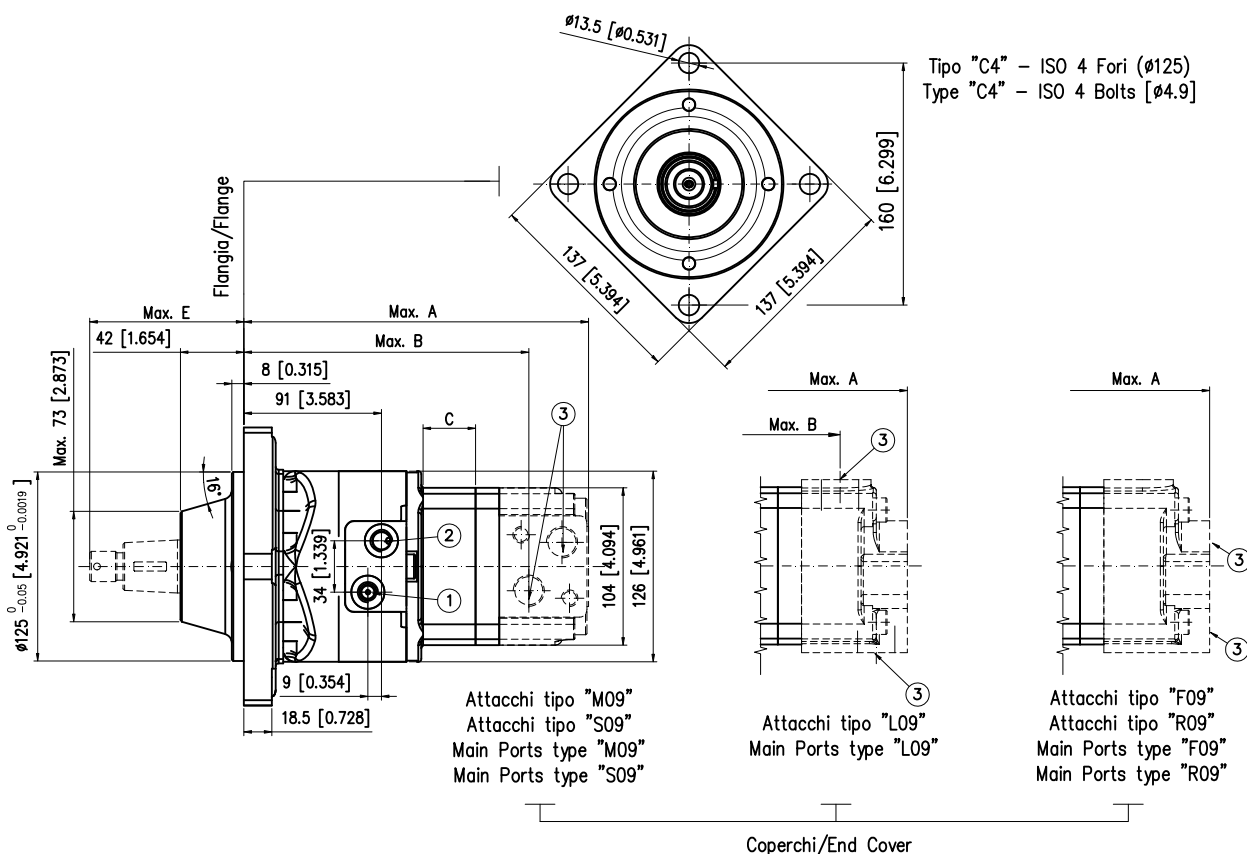

Tipo "C4" - ISO 4 Fori (Ø125)
 Type "C4" - ISO 4 Bolts [Ø4.9]

- 1) Comando apertura freno 1/8 G (BSPP) Prof.fil. 11mm (ISO)
 1/8 G (BSPP) Brake releasing plug, thread depth [0.42 in] (ISO)
 Comando apertura freno 7/16" - 20 UNF Prof.fil. 11mm (SAE)
 7/16" - 20 UNF Brake releasing plug, thread depth [0.42 in] (SAE)
- 2) Drenaggio Motore 1/4 G (BSPP) Prof.fil. 11mm (ISO)
 1/4 G (BSPP) Drain port, thread depth [0.42 in] (ISO)
 Drenaggio Motore 7/16" - 20 UNF Prof.fil. 11mm (SAE)
 7/16" - 20 UNF Drain port, thread depth [0.42 in] (SAE)
- 3) Fori Alimentazione
 Main ports

*Per le dimensioni di alberi e attacchi vedere da pag. F/16 a pag. F/18
 *For shafts and main ports dimension see from pag. F/16 to pag. F/18
 ** Per caratteristiche freno vedere pag. F/20
 ** For brake feature see pag. F/20

Attacchi Tipo "M09" - Main Ports type "M09"									
Attacchi Tipo "S09" - Main Ports type "S09"									
Cil. (cm ³ /giro)	080	100	130	160	200	250	315	400	
Displ. [in ³ /rev]	[4.8]	[6.1]	[7.9]	[9.7]	[12.2]	[15.2]	[19.2]	[24.4]	
A mm	207.2	210.6	215	221	228	236.7	248	261.6	
A [in]	[8.15]	[8.29]	[8.46]	[8.70]	[8.97]	[9.31]	[9.76]	[10.29]	
B mm	167.7	171.1	175.5	181.5	188.5	197.2	208.5	222.1	
B [in]	[6.60]	[6.73]	[6.90]	[7.14]	[7.42]	[7.76]	[8.20]	[8.74]	
C mm	14	17.4	21.8	27.8	34.8	43.5	54.8	68.4	
C [in]	[0.551]	[0.68]	[0.85]	[1.09]	[1.37]	[1.71]	[2.15]	[2.69]	
Pesi kg	17.7	17.9	18.3	18.6	19	19.7	20.4	21.2	
Weight [lb]	[39]	[39.4]	[40.3]	[40.9]	[41.8]	[43.4]	[44.9]	[46.7]	

Attacchi Tipo "L09" - Main Ports type "L09"									
Attacchi Tipo "F09" - Main Ports type "F09"									
Attacchi Tipo "R09" - Main Ports type "R09"									
Cil. (cm ³ /giro)	080	100	130	160	200	250	315	400	
Displ. [in ³ /rev]	[4.8]	[6.1]	[7.9]	[9.7]	[12.2]	[15.2]	[19.2]	[24.4]	
A mm	218.2	221.6	226	232	239	247.7	259	272.6	
A [in]	[8.59]	[8.72]	[8.89]	[9.13]	[9.40]	[9.75]	[10.19]	[10.73]	
B mm	173.7	177.1	181.5	187.5	194.5	203.2	214.5	228.1	
B [in]	[6.83]	[6.97]	[7.14]	[7.38]	[7.65]	[8.00]	[8.44]	[8.98]	
C mm	14	17.4	21.8	27.8	34.8	43.5	54.8	68.4	
C [in]	[0.551]	[0.68]	[0.85]	[1.09]	[1.37]	[1.71]	[2.15]	[2.69]	
Pesi kg	17.7	17.9	18.3	18.6	19	19.7	20.4	21.2	
Weight [lb]	[39]	[39.4]	[40.3]	[40.9]	[41.8]	[43.4]	[44.9]	[46.7]	

ALBERO	CL320	CN320
SHAFT		
E mm	101	102
E [in]	[3.97]	[4.01]

VERSIONE CORTA - "C"
"C" - BEARINGLESS VERSION

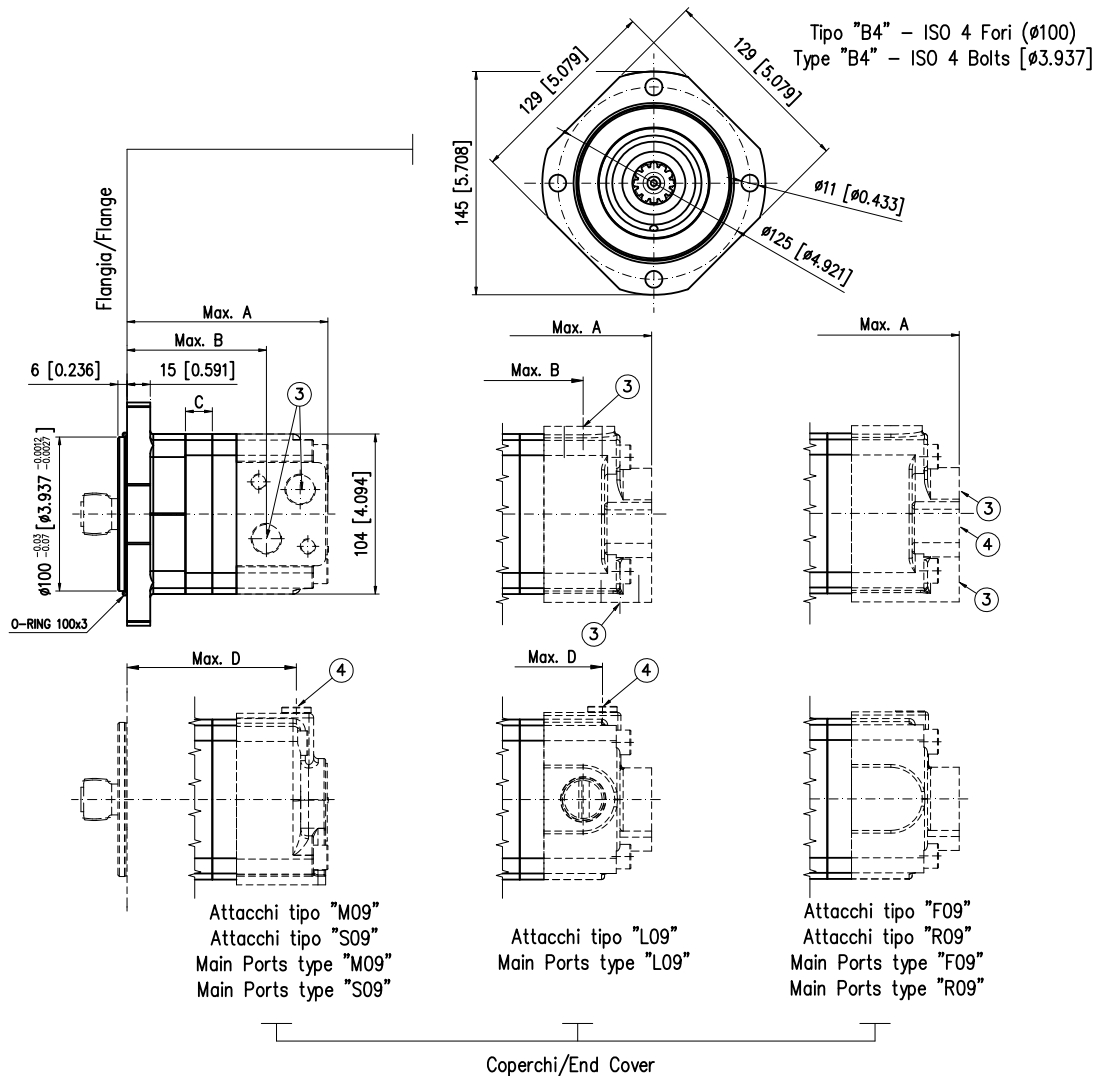

- 3) Fori Alimentazione
Main ports
- 4) Drenaggi motore
Drain port

*Per le dimensioni degli attacchi vedere da pag. F/17 a pag. F/18
 ** Per la sede di accoppiamento vedere pag. F/15
 *For main ports dimension see from pag. F/17 to pag. F/18
 ** For interface drawing see pag. F/15

Attacchi Tipo "M09" - Main Ports type "M09" Attacchi Tipo "S09" - Main Ports type "S09"								
Cil. (cm ³ /giro)	080	100	130	160	200	250	315	400
Displ. [in ³ /rev]	[4.8]	[6.1]	[7.9]	[9.7]	[12.2]	[15.2]	[19.2]	[24.4]
A mm	127.7	131	135.5	141.5	148.5	157.2	168.5	182
A [in]	[5.02]	[5.15]	[5.33]	[5.57]	[5.84]	[6.18]	[6.63]	[7.16]
B mm	87.2	90.6	95	101	108	116.7	128	141.6
B [in]	[3.43]	[3.56]	[3.74]	[3.97]	[4.25]	[4.59]	[5.03]	[5.57]
C mm	14	17.4	21.8	27.8	34.8	43.5	54.8	68.4
C [in]	[0.551]	[0.68]	[0.85]	[1.09]	[1.37]	[1.71]	[2.15]	[2.69]
D mm	106.7	110	114.5	120.5	127.5	136.2	147.5	161
D [in]	[4.20]	[4.33]	[4.50]	[4.74]	[5.01]	[5.36]	[5.80]	[6.33]
Pesi kg	8	8.2	8.6	8.9	9.3	10	10.7	11.5
Weight (lb)	[17.6]	[18]	[18.9]	[19.6]	[20.4]	[22]	[23.5]	[25.3]

Attacchi Tipo "L09" - Main Ports type "L09" Attacchi Tipo "F09" - Main Ports type "F09" Attacchi Tipo "R09" - Main Ports type "R09"								
Cil. (cm ³ /giro)	080	100	130	160	200	250	315	400
Displ. [in ³ /rev]	[4.8]	[6.1]	[7.9]	[9.7]	[12.2]	[15.2]	[19.2]	[24.4]
A mm	140.7	144	149.5	154.5	161.5	170.2	181.5	195
A [in]	[5.53]	[5.66]	[5.88]	[6.08]	[6.35]	[6.70]	[7.14]	[7.67]
B mm	93.2	96.6	101	107	114	122.7	134	147.6
B [in]	[3.66]	[3.80]	[3.97]	[4.21]	[4.48]	[4.83]	[5.27]	[5.81]
C mm	14	17.4	21.8	27.8	34.8	43.5	54.8	68.4
C [in]	[0.551]	[0.68]	[0.85]	[1.09]	[1.37]	[1.71]	[2.15]	[2.69]
D mm	104.2	107.5	112	118	125	133.7	145	158.5
D [in]	[4.10]	[4.23]	[4.40]	[4.64]	[4.92]	[5.26]	[5.70]	[6.24]
Pesi kg	8	8.2	8.6	8.9	9.3	10	10.7	11.5
Weight (lb)	[17.6]	[18]	[18.9]	[19.6]	[20.4]	[22]	[23.5]	[25.3]

VERSIONE CORTA PER RIDUTTORE - "M"
"M" - SHORT BEARINGLESS VERSION FOR GEAR BOX

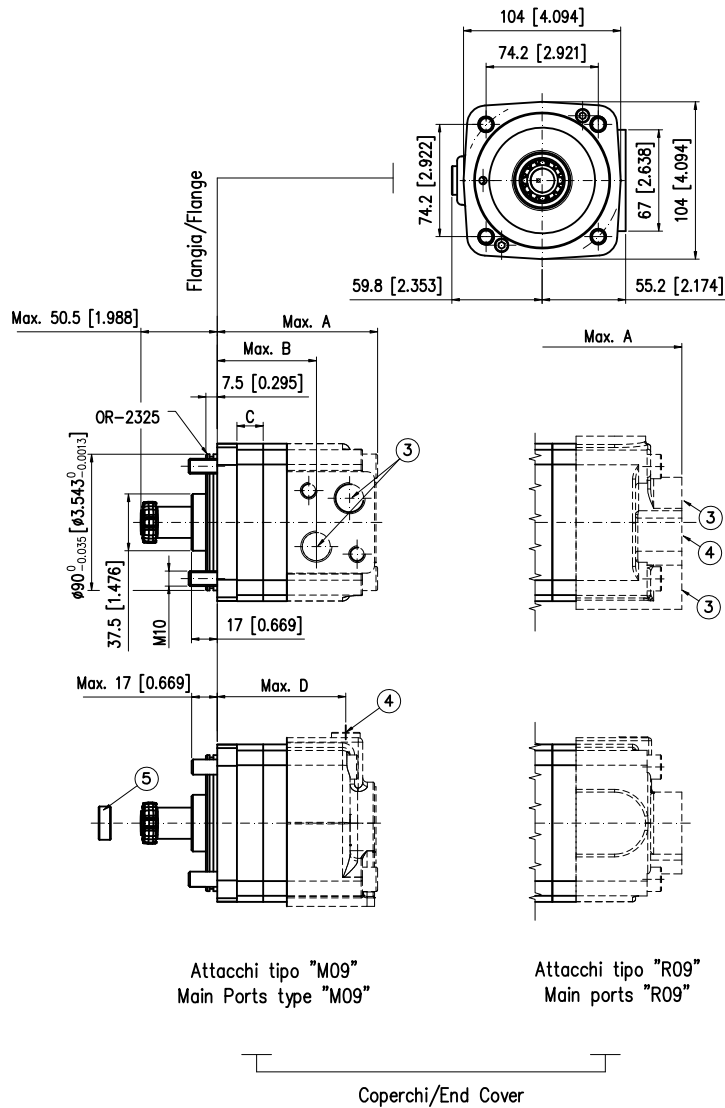

- 3) Fori di alimentazione
Main ports
- 4) Drenaggio Motore
Drain port
- 5) I motori sono forniti con distanziale
The motors are supplied with spacer

* Per la sede di accoppiamento vedere pag. F/15
 * For interface drawing see pag. F/15

Attacchi Tipo "M09" - Main Ports type "M09"								
Cil. (cm ³ /giro)	080	100	130	160	200	250	315	400
Displ. [in ³ /rev]	[4.8]	[6.1]	[7.9]	[9.7]	[12.2]	[15.2]	[19.2]	[24.4]
A mm	102.6	106	110.4	116.4	123.4	132.1	143.4	157
A [in]	[4.03]	[4.17]	[4.34]	[4.58]	[4.85]	[5.20]	[5.64]	[6.18]
B mm	62.2	65.6	70	76	83	91.7	103	116.6
B [in]	[2.44]	[2.58]	[2.75]	[2.99]	[3.26]	[3.61]	[4.05]	[4.59]
C mm	14	17.4	21.8	27.8	34.8	43.5	54.8	68.4
C [in]	[0.551]	[0.68]	[0.85]	[1.09]	[1.37]	[1.71]	[2.15]	[2.69]
D mm	81.6	85	89.4	95.4	102.4	111.1	122.4	136
D [in]	[3.21]	[3.34]	[3.51]	[3.75]	[4.03]	[4.37]	[4.81]	[5.35]
Pesi kg	6.5	6.7	7.1	7.5	8	8.6	9.4	10.3
Weight (lb)	[14.3]	[14.7]	[15.6]	[16.5]	[17.6]	[18.9]	[20.7]	[22.7]

Attacchi Tipo "R09" - Main Ports type "R09"								
Cil. (cm ³ /giro)	080	100	130	160	200	250	315	400
Displ. [in ³ /rev]	[4.8]	[6.1]	[7.9]	[9.7]	[12.2]	[15.2]	[19.2]	[24.4]
A mm	112.5	115.9	120.3	126.3	133.3	142	153.3	166.9
A [in]	[4.42]	[4.56]	[4.73]	[4.97]	[5.24]	[5.59]	[6.03]	[6.57]
B mm	/	/	/	/	/	/	/	/
B [in]	/	/	/	/	/	/	/	/
C mm	14	17.4	21.8	27.8	34.8	43.5	54.8	68.4
C [in]	[0.551]	[0.68]	[0.85]	[1.09]	[1.37]	[1.71]	[2.15]	[2.69]
D mm	/	/	/	/	/	/	/	/
D [in]	/	/	/	/	/	/	/	/
Pesi kg	8	8.2	8.6	8.9	9.3	10	10.7	11.5
Weight (lb)	[17.6]	[18]	[18.9]	[19.6]	[20.4]	[22]	[23.5]	[25.3]

SEDE DI ACCOPPIAMENTO PER MOTORE HR VERSIONE "C" INTERFACE DRAWING FOR HR MOTOR "C" VERSION

Profilo scanalato ANS B 92.1 + 1970 Classe 5 (corretto $m \cdot x=0.8$) Splines ANS B 92.1 + 1970 Class 5 (corrected $m \cdot x=0.8$)	
Diametral pitch	12/24
N° denti Number of teeth	Z=12
Diametro primitivo Pitch diameter	Dp=25.4
Angolo di pressione Pressure angle	30°
Modulo Module	m=2.1166
Diametro interno Minor diameter	Di=23.0 $\begin{matrix} +0.033 \\ 0 \end{matrix}$
Diametro esterno Major diameter	De=28.0 $\begin{matrix} 0 \\ -0.1 \end{matrix}$
Misura massima tra i rullini* Max measurement between pins*	17.62 $\begin{matrix} +0.15 \\ 0 \end{matrix}$
Diametro rullini Pins diameter	4.835 ± 0.001
* Dimensioni definitive dopo il trattamento * Finished dimensions (when hardened)	

La placchetta di fermo deve essere indurita ad HRc 55^{±2}
The lock plate must be hardened according to HRc 55^{±2}

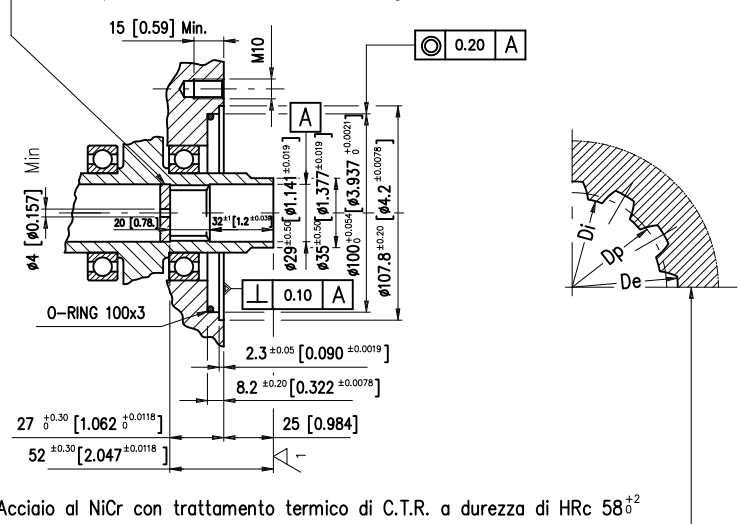

Acciaio al NiCr con trattamento termico di C.T.R. a durezza di HRc 58^{±2}
NiCr steel with case hardening, induction hardening and tempering treatment, with hardness HRc 58^{±2}

SEDE DI ACCOPPIAMENTO PER MOTORE HR VERSIONE "M" INTERFACE DRAWING FOR HR MOTOR "M" VERSION

Profilo scanalato ANS B 92.1 + 1970 Classe 5 (corretto $m \cdot x=0.8$) Splines ANS B 92.1 + 1970 Class 5 (corrected $m \cdot x=0.8$)	
Diametral pitch	12/24
N° denti Number of teeth	Z=12
Diametro primitivo Pitch diameter	Dp=25.4
Angolo di pressione Pressure angle	30°
Modulo Module	m=2.1166
Diametro interno Minor diameter	Di=23.0 $\begin{matrix} +0.033 \\ 0 \end{matrix}$
Diametro esterno Major diameter	De=28.0 $\begin{matrix} 0 \\ -0.1 \end{matrix}$
Misura massima tra i rullini* Max measurement between pins*	17.62 $\begin{matrix} +0.15 \\ 0 \end{matrix}$
Diametro rullini Pins diameter	4.835 ± 0.001
* Dimensioni definitive dopo il trattamento * Finished dimensions (when hardened)	

La placchetta di fermo deve essere indurita ad HRc 55^{±2}
The lock plate must be hardened according to HRc 55^{±2}

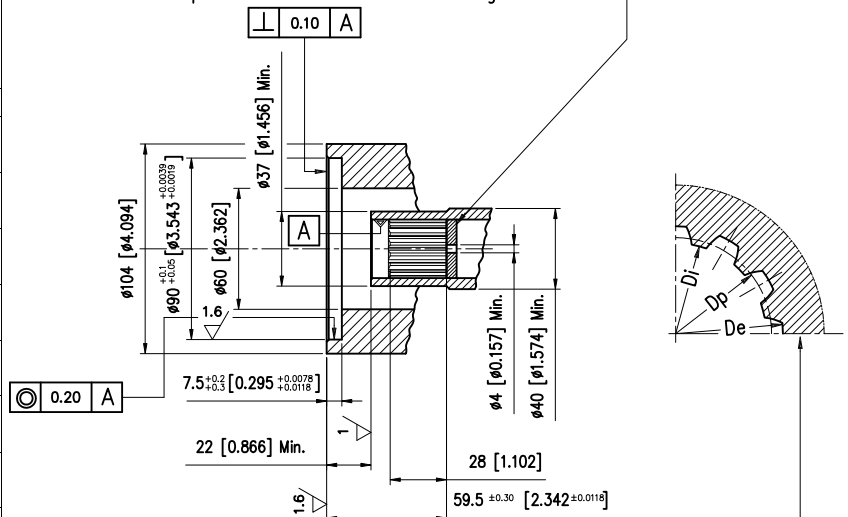

Acciaio al NiCr con trattamento termico di C.T.R. a durezza di HRc 58^{±2}
NiCr steel with case hardening, induction hardening and tempering treatment, with hardness HRc 58^{±2}

ALBERO CILINDRICO CL254 CL254 CYLINDRICAL SHAFT

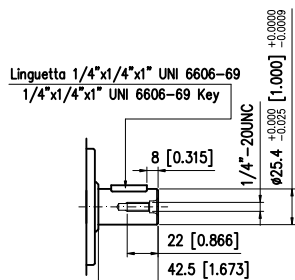

Coppia max ammissibile (Cont. 300 Nm - Int. 410 Nm)
Max. admissible Torque (Cont. 300 Nm [221 lbf-ft] - Int. 410 Nm [302 lbf-ft])

ALBERO SCANALATO SE250 SE250 SPLINED SHAFT

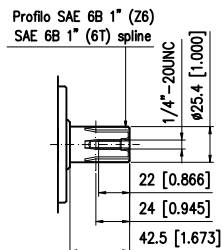

Coppia max ammissibile (Cont. 360 Nm - Int. 450 Nm)
Max. admissible Torque (Cont. 360 Nm [265 lbf-ft] - Int. 450 Nm [332 lbf-ft])

ALBERO CILINDRICO C3175 C3175 CYLINDRICAL SHAFT

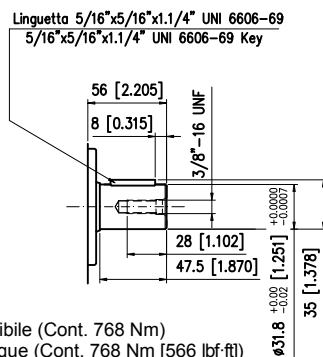

Coppia max ammissibile (Cont. 768 Nm)
Max. admissible Torque (Cont. 768 Nm [566 lbf-ft])

ALBERO SCANALATO SC320 SC320 SPLINED SHAFT

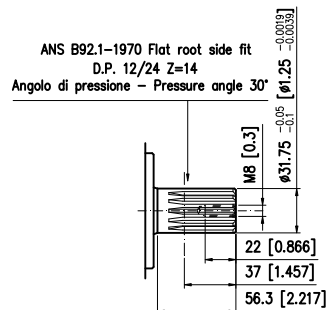

Coppia max ammissibile (Cont. 768 Nm)
Max. admissible Torque (Cont. 768 Nm [566 lbf-ft])

ALBERO CILINDRICO CL320 CL320 CYLINDRICAL SHAFT

Coppia max ammissibile (Cont. 768 Nm)
Max. admissible Torque (Cont. 768 Nm [566 lbf-ft])

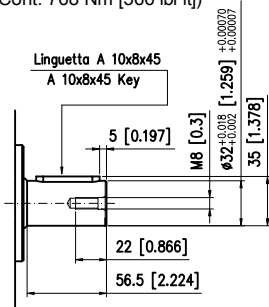

ALBERO SCANALATO SE320 SE320 SPLINED SHAFT

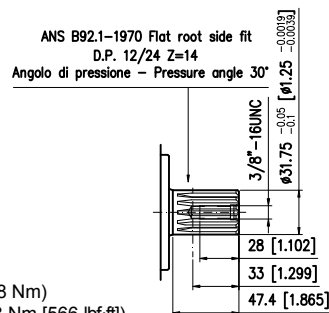

Coppia max ammissibile (Cont. 768 Nm)
Max. admissible Torque (Cont. 768 Nm [566 lbf-ft])

ALBERO CONICO CN320 CN320 TAPERED SHAFT

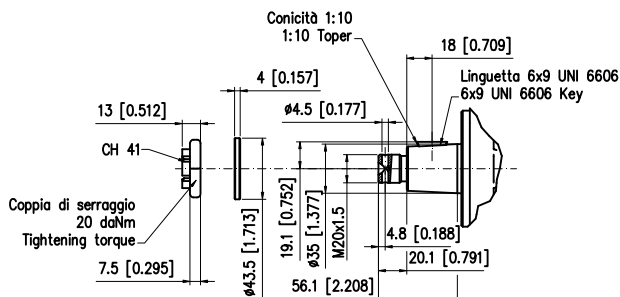

Coppia max ammissibile (Cont. 860 Nm)
Max. admissible Torque (Cont. 860 Nm [633.82 lbf-ft])

ALBERO SCANALATO SE350 SE350 SPLINED SHAFT

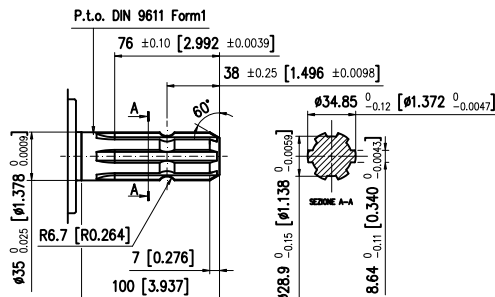

Coppia max ammissibile (Cont. 860 Nm)
Max. admissible Torque (Cont. 860 Nm [633.82 lbf-ft])

DIMENSIONI ATTACCHI E SENSO DI ROTAZIONE MAIN PORTS DIMENSIONS AND DIRECTION OF ROTATION

ATTACCHI TIPO M09 MAIN PORTS TYPE M09

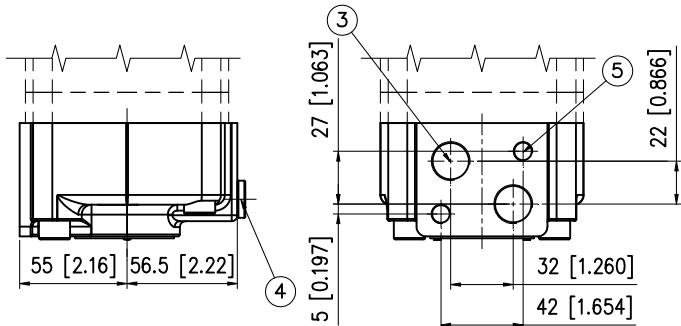

- 3) N° 2 Fori di alimentazione 1/2 G (BSPP) profondità filetto 15mm
N° 2 Bolts 1/2 G (BSPP) main ports thread depth [0.59 in]
- 4) Drenaggio motore 1/4 G (BSPP) profondità filetto 13mm
1/4 G (BSPP) drain port thread depth [0.511 in]
- 5) N° 2 M10 profondità filetto 15mm
N° 2 M10 thread depth [0.59 in]

Versione S
S Version

Versione C
C Version

Versione W
W Version

Versione F
F Version

Versione L
L Version

Versione M
M Version

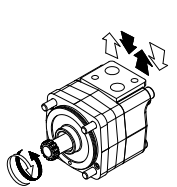
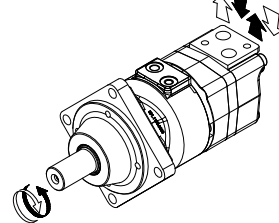
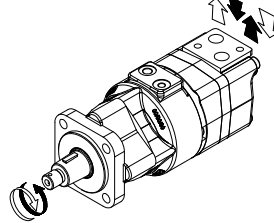
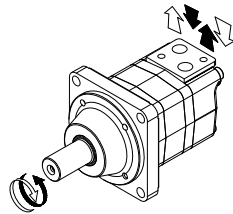
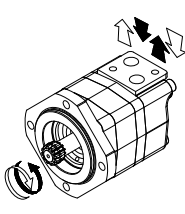
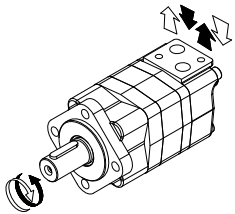

ATTACCHI TIPO S09 MAIN PORTS TYPE S09

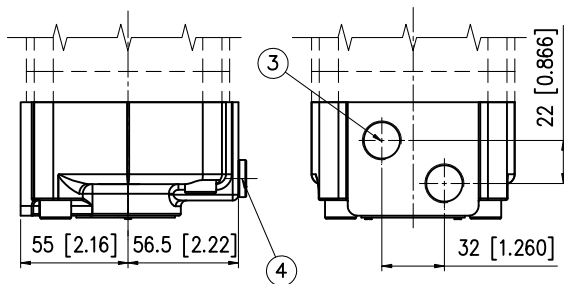

- 3) N° 2 Fori di alimentazione 7/8" - 14 UNF profondità filetto 17mm
N° 2 Bolts 7/8" - 14 UNF main ports thread depth [0.66 in]
- 4) Drenaggio motore 7/16" - 20 UNF profondità filetto 13mm
7/16" - 20 UNF drain port thread depth [0.511 in]

Versione S
S Version

Versione C
C Version

Versione W
W Version

Versione F
F Version

Versione L
L Version

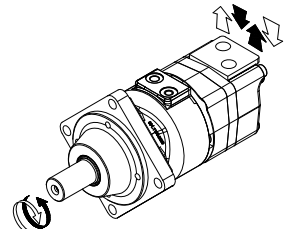
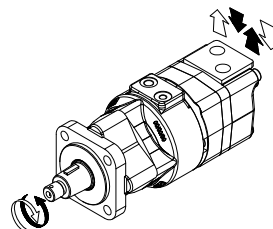
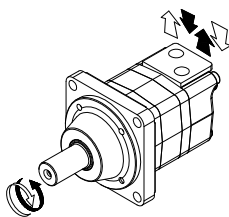
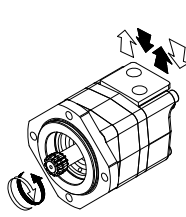
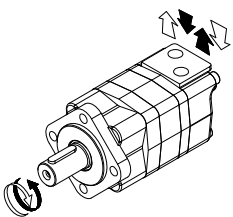

**ATTACCHI LATERALI TIPO L09
MAIN PORTS POSITIONED 180° APART TYPE L09**

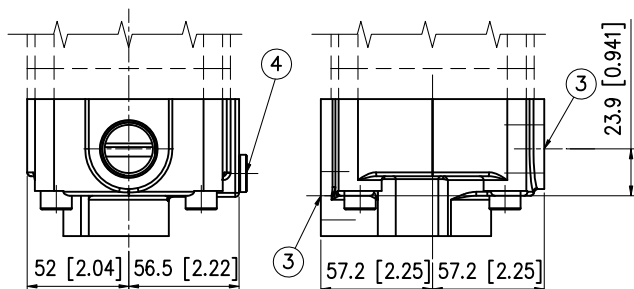

- 3) N° 2 Fori di alimentazione 1" 1/16 - 12 UN profondità filetto 20mm
N° 2 Bolts 1" 1/16 - 12 UN main ports thread depth [0.78 in]
- 4) Drenaggio motore 7/16" - 20 UNF profondità filetto 13mm
7/16" - 20 UNF drain port thread depth [0.511 in]

**Versione S
S Version**

**Versione C
C Version**

**Versione W
W Version**

**Versione F
F Version**

**Versione L
L Version**

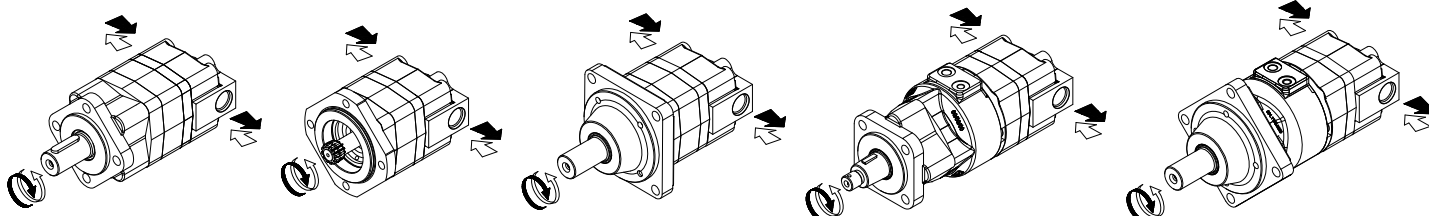

**ATTACCHI FRONTALI TIPO F09
END MAIN PORTS TYPE F09**

**ATTACCHI FRONTALI TIPO R09
END MAIN PORTS TYPE R09**

**A RICHIESTA
UPON REQUEST**

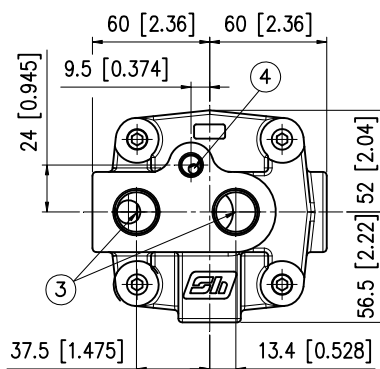
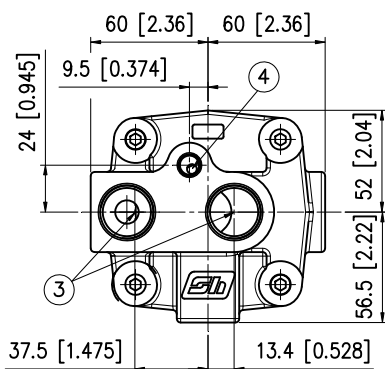

- 3) N° 2 Fori di alimentazione 1" 1/16 - 12 UN profondità filetto 17mm
N° 2 Bolts 1" 1/16 - 12 UN main ports thread depth [0.66 in]
- 4) Drenaggio motore 7/16" - 20 UNF profondità filetto 13mm
7/16" - 20 UNF drain port thread depth [0.511 in]

- 3) N° 2 Fori di alimentazione 7/8" - 14 UNF profondità filetto 17mm
N° 2 Bolts 7/8" - 14 UNF main ports thread depth [0.66 in]
- 4) Drenaggio motore 7/16" - 20 UNF profondità filetto 13mm
7/16" - 20 UNF drain port thread depth [0.511 in]

**Versione S
S Version**

**Versione C
C Version**

**Versione W
W Version**

**Versione F
F Version**

**Versione L
L Version**

**Versione M
M Version**

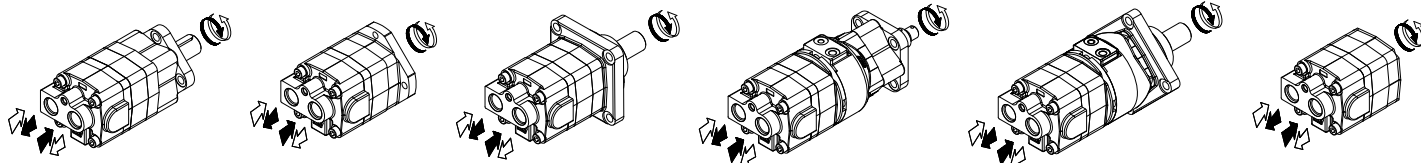

ATTACCO DRENAGGIO SECONDARIO (LATO MANDATA) SECONDARY DRAIN PORT (AT DELIVERY SIDE)

Per i motori con versione S-W-C è possibile inserire un secondario attacco di drenaggio (lato mandata).

Se si vuole predisporre il motore con un secondario attacco di drenaggio è necessario specificare in fase d'ordine il valore "OK" per versione metrica o "SK" per versione SAE (vedere punto 2A del codice di ordinazione).

For the motor with S-W-C version, it is possible to put a secondary drain port (at delivery side).

If it is necessary on the motor a secondary drain port, to specify in the purchase order the value "OK" for metric version or "SK" for SAE version (See position 2A of ordering code)

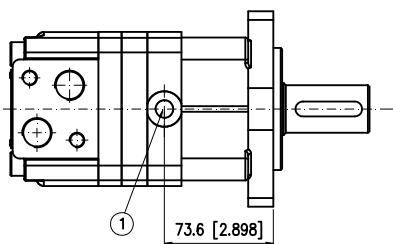

Versione S
S Version

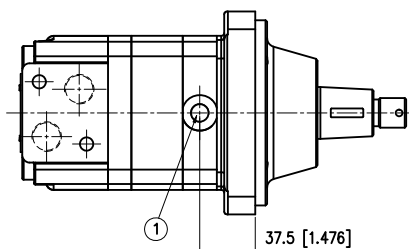

Versione W
W Version

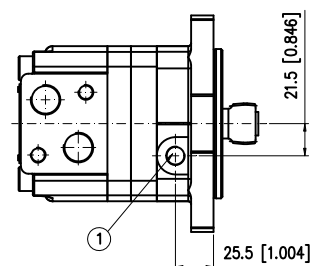

Versione C
C Version

- 1) Drenaggio motore 1/4 G (BSPP) (OK)
1/4 G (BSPP) drain port (OK)
Drenaggio motore 7/16" - 20 UNF (SK)
7/16" - 20 UNF drain port (SK)

BASSI TRAFILAMENTI LOW LEAKAGE

E' raccomandata la versione Bassi Trafilamenti, in caso di applicazioni a basse portate e contemporaneamente alta pressione di esercizio.

La versione Bassi Trafilamenti, differisce dalla versione Standard, per dei componenti interni differenti.

For applications with low flow and high working pressure, it is recommended the Low Leakage version.

The Low Leakage version differs from the standard version for the different internal components.

COPERCHIO SPECIALE PER VALVOLA DI LAVAGGIO SPECIAL COVER FOR FLUSHING VALVE

Per il montaggio diretto della valvola di lavaggio sui motori è necessario utilizzare un coperchio speciale.

Questo è possibile solo con gli attacchi "M09 - S09".

Se si vuole predisporre il motore con valvola di lavaggio è necessario specificare in fase d'ordine il tipo di valvola 06-09-15-21 (vedere il punto 9 del codice di ordinazione)

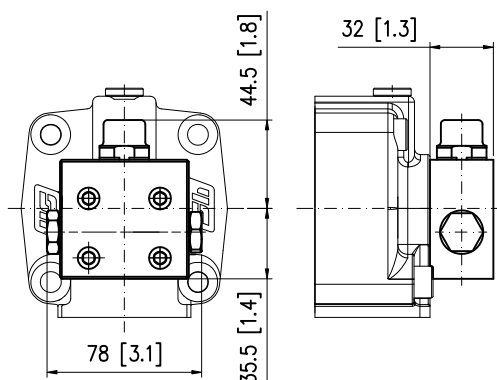

The mount the flushing valve on motors, it is necessary to use a special cover.

This is only possible with the "M09 - S09" main ports.

If it is necessary to assembly the flushing valve on motors, to specify in the purchase order the valves type 06-09-15-21 (See position 9 of ordering code)

Per maggiori informazioni sulla valvola di lavaggio, consultare la sezione Valvole ed Accessori o il Bollettino Informativo 05-0082-A04
For more informations on the Flushing valve, see the Valves and Accessories section or Service Bulletin - 05-0082-A04

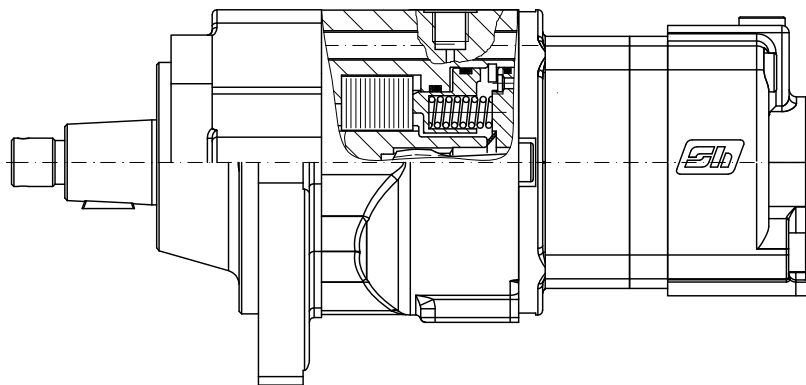

Pressione di apertura minima Starting release pressure	25 bar [362 psi]
Pressione freno libero Full release pressure	30 bar [435 psi]
Pressione comando freno Max. Brake control pressure Max.	210 bar [3045 psi]

MOTORE MOTOR	COPPIA STATICA DI FRENATURA STATIC BRAKING TORQUE			
	STANDARD	12 MOLLE / 10 CONTATTI 12 SPRINGS / 10 CONTACTS	8 MOLLE 8 SPRINGS	COPPIA MAGGIORATA INCREASED BRAKING TORQUE
Versione F - Versione L 080 F Version - L Version 080	210 Nm [154.7 lbf-ft]			
Versione F - Versione L 100 F Version - L Version 100	280 Nm [206.3 lbf-ft]	259 Nm [190.8 lbf-ft]		
Versione F - Versione L 130 F Version - L Version 130	340 Nm [250.5 lbf-ft]			
Versione F - Versione L 160 F Version - L Version 160	340 Nm [250.5 lbf-ft]			
Versione F - Versione L 200 F Version - L Version 200	420 Nm [309.5 lbf-ft]			560 Nm [412.7 lbf-ft]
Versione F - Versione L 250 F Version - L Version 250	470 Nm [346.3 lbf-ft]		313 Nm [230.6 lbf-ft]	560 Nm [412.7 lbf-ft]
Versione F - Versione L 315 F Version - L Version 315	560 Nm [412.7 lbf-ft]	259 Nm [190.8 lbf-ft]	373 Nm [274.9 lbf-ft]	
Versione F - Versione L 400 F Version - L Version 400	560 Nm [412.7 lbf-ft]		373 Nm [274.9 lbf-ft]	

I freni integrati dei motori-freno versione F e versione L sono del tipo multidisco a sblocco sotto pressione per uso in condizioni statiche. Quando l'olio proveniente dalla pompa non è in pressione, una serie di molle mantiene premuti i dischi gli uni contro gli altri; pertanto, l'albero del motore non potrà ruotare se non trascinato da una coppia che ecceda di molto la massima coppia di frenatura statica del freno. Inviando olio al motore, una valvola di commutazione (da inserire nell'impianto) devia al freno parte del flusso, vincendo così la resistenza delle molle che, sbloccando il freno, consentono la partenza del motore. I motori ruota necessitano di alcune attenzioni per quanto riguarda la progettazione della macchina da azionare. Gli aspetti più importanti da considerare sono:

- 1) Le conicità di mozzo ed albero motore devono combaciare perfettamente, in modo da evitare sovraccarichi sulla chiavetta, che potrebbero verificarsi qualora la rondella dell'albero andasse in appoggio sulla fine della parte conica dell'albero.
- 2) In caso di urti all'albero (come nel caso di macchine mobili che traslano su terreno sconnesso) si dovrà considerare un adeguato fattore di servizio.
- 3) I motori-freno versione L che azionano macchine mobili dovrebbero sempre essere protetti da una valvola doppia overcentre con commutatore, flangiata in modo da assicurare un sicuro rallentamento della macchina e l'entrata in funzione del freno all'arresto.

The brakes built into F version and L version motors are multidisc pressure released ones for static operation. With no pressure from the pump to the motor, a set of springs will push the discs one against the other, hence the motor shaft will not be allowed to rotate unless the shaft itself is driven with a torque widely exceeding the max. static torque of the brake. By sending pressure to the motor a shuttle valve (to be included in the system) will send pressure to the brake, overcome the resistance of the springs and release the brake hence allowing the start of the motor. Wheel motors require some care in the engineering of the machine. The major aspects to consider are:

- 1) Hub and motor shaft tapers must be perfectly matching, in order to avoid excessive key stress, which can occur in case of bottoming of shaft tip washer and nut at the end of the thread.
- 2) A proper service factor should be considered in case of shocks to the shaft (eg. With the machine travelling on very uneven soil).
- 3) L version brake motors operating mobile machines should always have a flanged on double overcentre + shuttle valve, in order to ensure safe slow-down of the machine and engaging of brake when a complete stop has been reached.

CIRCUITO APERTO, UN MOTORE FRENO, ROTAZIONE IN ENTRAMBE LE DIREZIONI ED AZIONAMENTO FRENO AUTOMATICO.

Questa è la tipica configurazione di un sistema di rotazione (gru, escavatori, piattaforme mobili, falconi, etc.). Quando la pompa invia olio al motore la pressione aziona la valvola di commutazione che, attivando la linea del freno, ne consente il rilascio. La valvola doppia overcentre rallenta la massa in rotazione fino quasi all'arresto, quando entra in azione il freno statico.

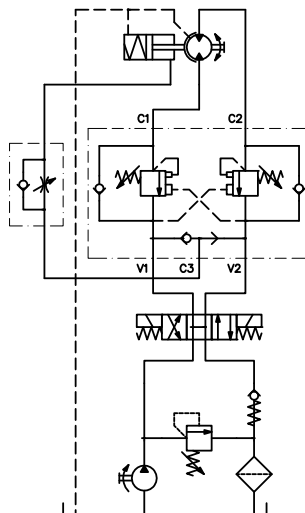

OPEN LOOP SYSTEM, ONE BRAKE-MOTOR, BI-DIRECTIONAL TURNING AND AUTOMATIC BRAKE OPERATION.

This configuration is typically that of a slew drive (cranes, excavators, aerial platforms, derricks, etc.). When the pump delivers oil to the motor the consequent generation of pressure will operate the shuttle valve and activate the brake line, thus disengaging the brake itself. When the oil delivery is shut off to stop the machine, a double overcentre valve will slow down the rotative mass to an almost complete stop when the static brake will engage.

CIRCUITO APERTO, DUE MOTORI FRENO, ROTAZIONE IN ENTRAMBE LE DIREZIONI ED AZIONAMENTO AUTOMATICO DEL FRENO.

Questo è uno schema abbastanza comune di un impianto di traslazione per macchine mobili (piattaforme aeree, etc.). Il fluido in pressione sblocca il freno e fa partire i due motori; una apposita valvola collega i due motori o in serie o in parallelo in modo da avere più velocità o più coppia. La doppia valvola overcentre rallenta con sicurezza la macchina e la porta fino quasi all'arresto, quando i due freni statici entrano in funzione.

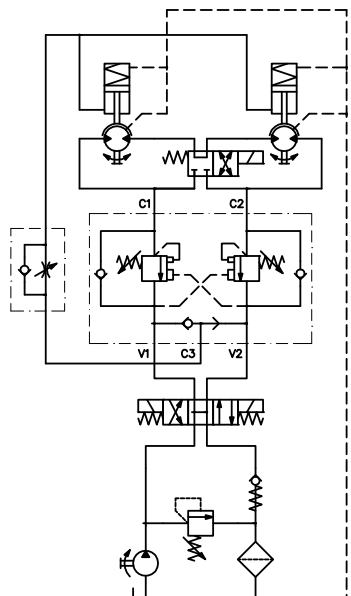

OPEN LOOP SYSTEM, TWO BRAKE-MOTORS, BI-DIRECTIONAL TURNING AND AUTOMATIC BRAKES OPERATION.

This is a typical layout of the travelling system of a mobile machine (aerial platforms, etc.). Fluid under pressure disengages the brakes and starts the two motors; a commutation device will connect the two motors either in series or parallel mode in order to have either speed or torque as main performance. The double overcentre valve will steadily slow down the machine and bring it to an almost complete stop when the brakes will engage.

CIRCUITO CHIUSO, UN MOTORE FRENO, ROTAZIONE IN ENTRAMBE LE DIREZIONI, FRENATURA AUTOMATICA, POMPA A PORTATA VARIABILE.

Questo è un tipico impianto di traslazione per spazzatrici ad una ruota motrice. La pompa impiegata consente di azionare il motore a velocità variabile. Il freno viene sbloccato dall'invio di olio dalla valvola commutatrice attraverso l'elettrovalvola che consente anche il deflusso del fluido in pressione dalla camera del freno quando il motore si arresta ed in freno stesso entra in azione.

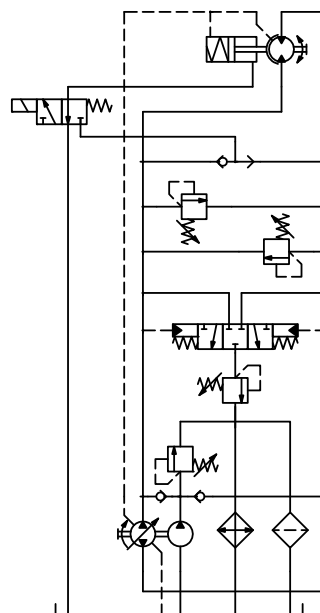

CLOSED LOOP SYSTEM, ONE BRAKE-MOTOR, BI-DIRECTIONAL TURNING, AUTOMATIC BRAKE OPERATION AND VARIABLE PUMP.

A very typical system for sweepers. The pump delivers a variable flow of oil to the motor hence the machine can travel at variable speed. The brake is disengaged by the delivery of flow from the shuttle valve via the electro-valve (top, right) that will also release the fluid under pressure from inside the brake piston chamber when the motor stops and the brake engages.

Versione S - Versione F
S Version - F Version

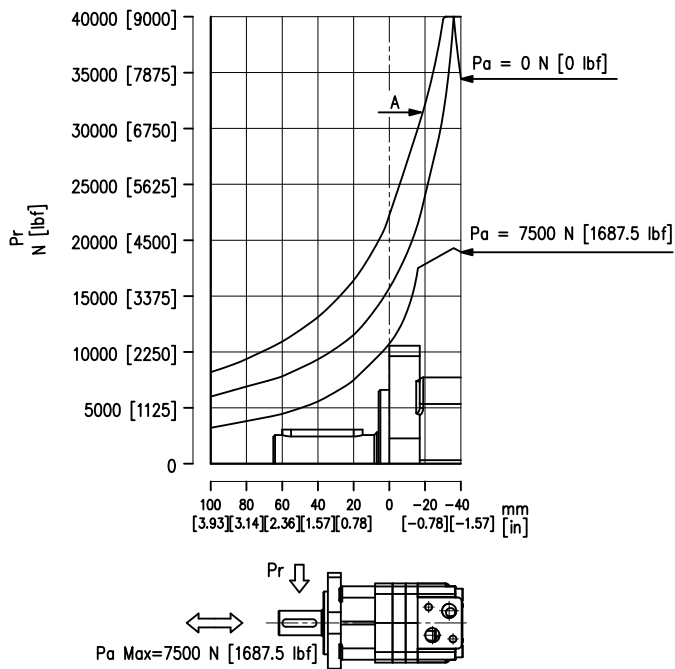

Il diagramma dei carichi è valido per una vita dei cuscinetti L_{10h} di 1600 ore alla velocità di 200 giri/min quando viene utilizzato olio a base minerale minerale con un adeguato contenuto di additivi anti usura. La vita dei cuscinetti è stata calcolata con un grado di affidabilità del 90%.

La curva "A" fornisce il carico radiale limite sopportato dai cuscinetti in condizioni di carico statico massimo.

Versione W - Versione L
W Version - L Version

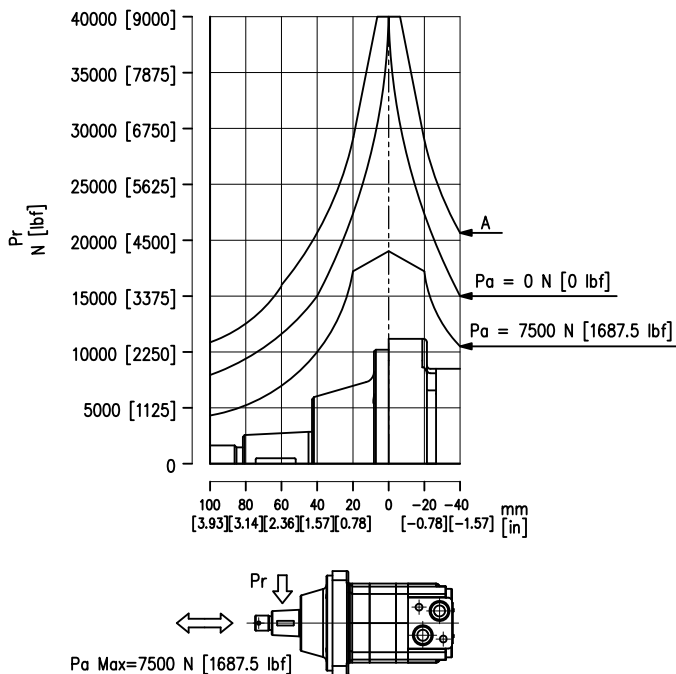

Loads diagram is for a bearings life L_{10h} of 1600 hours at 200 rpm when mineral base hydraulic oil with a sufficient content of anti-wear additives is used. Bearing life calculation refers to a 90% degree of reliability.

Curve "A" shows the maximum radial load that can be taken by the bearings uner maximum static load duty.

HR 080

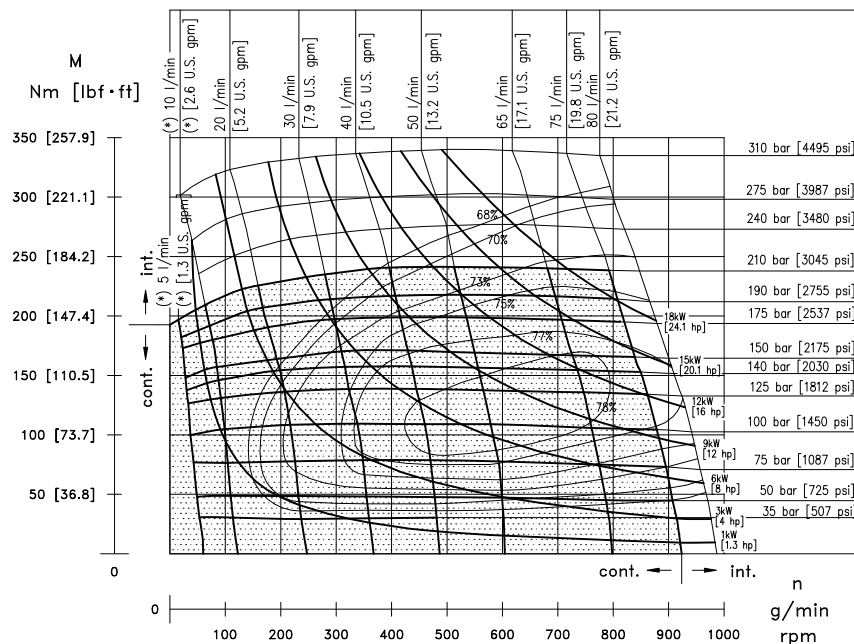

Pressioni e portate superiori a quelle ammesse in regime continuo non devono essere applicate contemporaneamente.
Exceeding continuous pressure values or exceeding flow values indicated, must not occur simultaneously.

(*) Dati prestazionali riferiti a motori standard. Per ottenere prestazioni superiori, quando il motore viene utilizzato con portata inferiore a 10 l/min, utilizzare versione LW (Low Leakage).
Performances data are referred to standard motors. For obtain higher performances, when the motor is used with flow < 10 l/min [< 2.64 U.S. gpm], we suggest to use LW (Low Leakage) version.

HR 100

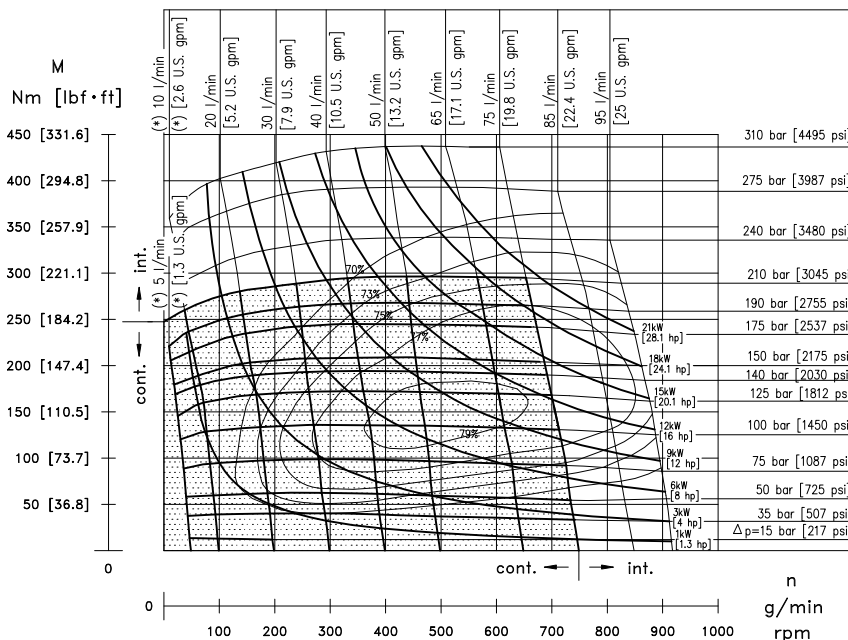

Pressioni e portate superiori a quelle ammesse in regime continuo non devono essere applicate contemporaneamente.
Exceeding continuous pressure values or exceeding flow values indicated, must not occur simultaneously.

(*) Dati prestazionali riferiti a motori standard. Per ottenere prestazioni superiori, quando il motore viene utilizzato con portata inferiore a 10 l/min, utilizzare versione LW (Low Leakage).
Performances data are referred to standard motors. For obtain higher performances, when the motor is used with flow < 10 l/min [< 2.64 U.S. gpm], we suggest to use LW (Low Leakage) version.

HR 130

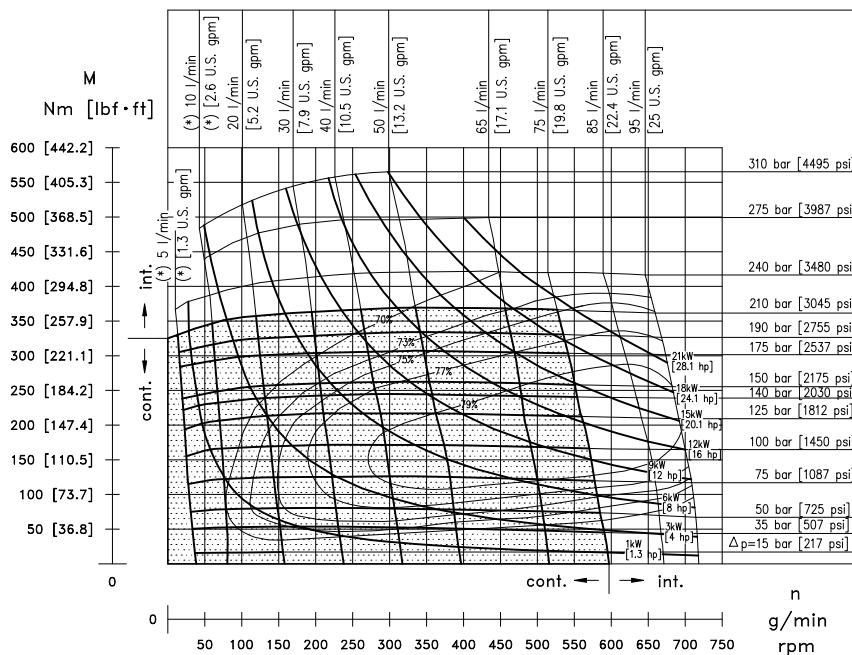

Pressioni e portate superiori a quelle ammesse in regime continuo non devono essere applicate contemporaneamente.
Exceeding continuous pressure values or exceeding flow values indicated, must not occur simultaneously.

(*) Dati prestazionali riferiti a motori standard. Per ottenere prestazioni superiori, quando il motore viene utilizzato con portata inferiore a 10 l/min, utilizzare versione LW (Low Leakage).
Performances data are referred to standard motors. For obtain higher performances, when the motor is used with flow < 10 l/min [< 2.64 U.S. gpm], we suggest to use LW (Low Leakage) version.

HR 160

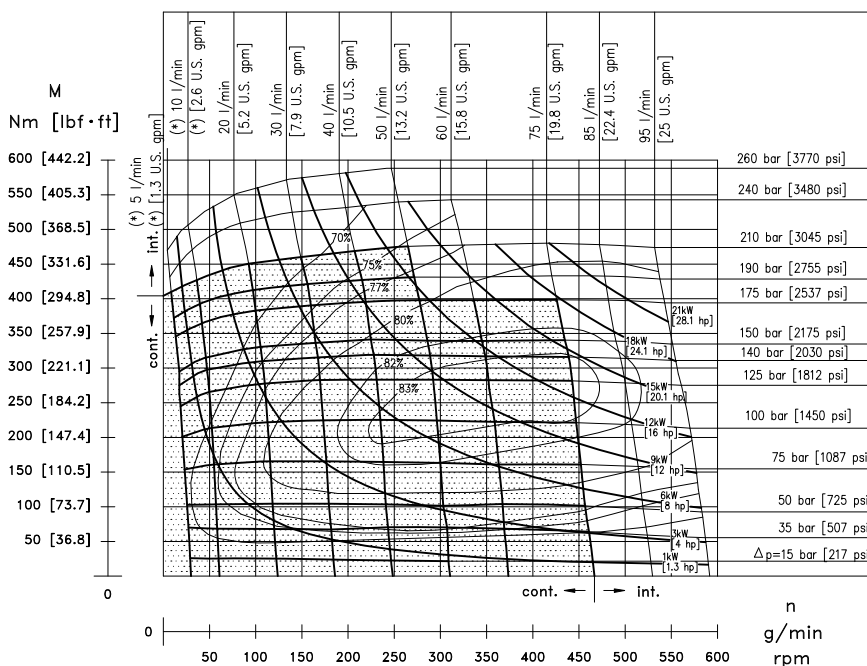

Pressioni e portate superiori a quelle ammesse in regime continuo non devono essere applicate contemporaneamente.
Exceeding continuous pressure values or exceeding flow values indicated, must not occur simultaneously.

(*) Dati prestazionali riferiti a motori standard. Per ottenere prestazioni superiori, quando il motore viene utilizzato con portata inferiore a 10 l/min, utilizzare versione LW (Low Leakage).
Performances data are referred to standard motors. For obtain higher performances, when the motor is used with flow < 10 l/min [< 2.64 U.S. gpm], we suggest to use LW (Low Leakage) version.

HR 200

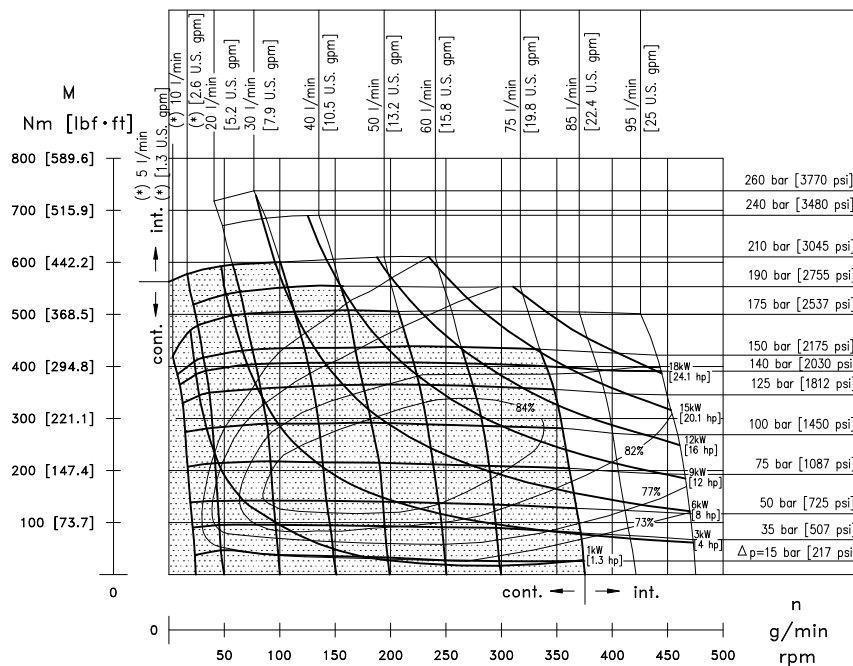

Pressioni e portate superiori a quelle ammesse in regime continuo non devono essere applicate contemporaneamente.
Exceeding continuous pressure values or exceeding flow values indicated, must not occur simultaneously.

(*) Dati prestazionali riferiti a motori standard. Per ottenere prestazioni superiori, quando il motore viene utilizzato con portata inferiore a 10 l/min, utilizzare versione LW (Low Leakage).
Performances data are referred to standard motors. For obtain higher performances, when the motor is used with flow < 10 l/min [< 2.64 U.S. gpm], we suggest to use LW (Low Leakage) version.

HR 250

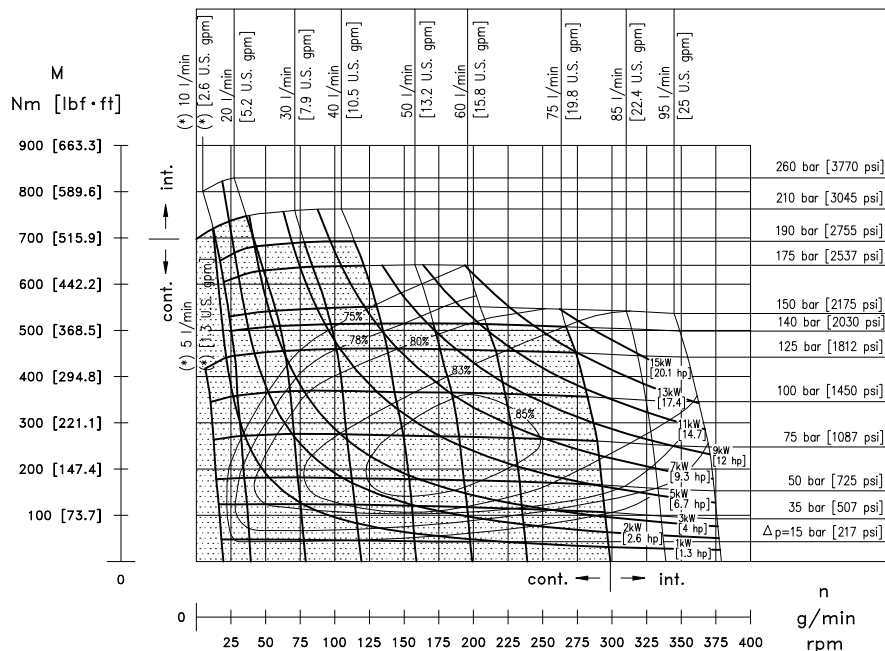

Pressioni e portate superiori a quelle ammesse in regime continuo non devono essere applicate contemporaneamente.
Exceeding continuous pressure values or exceeding flow values indicated, must not occur simultaneously.

(*) Dati prestazionali riferiti a motori standard. Per ottenere prestazioni superiori, quando il motore viene utilizzato con portata inferiore a 10 l/min, utilizzare versione LW (Low Leakage).
Performances data are referred to standard motors. For obtain higher performances, when the motor is used with flow < 10 l/min [< 2.64 U.S. gpm], we suggest to use LW (Low Leakage) version.

HR 315

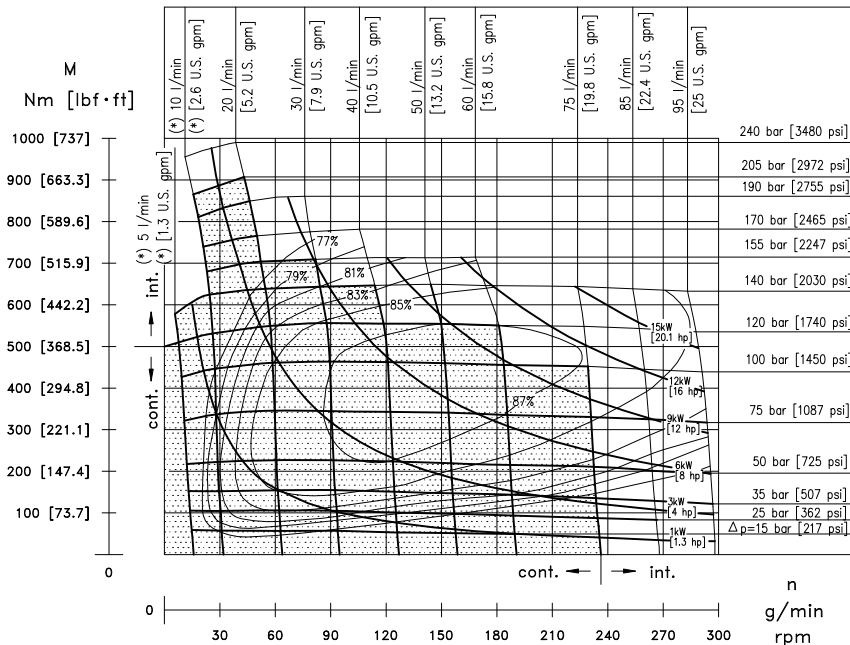

Pressioni e portate superiori a quelle ammesse in regime continuo non devono essere applicate contemporaneamente.
Exceeding continuous pressure values or exceeding flow values indicated, must not occur simultaneously.

(*) Dati prestazionali riferiti a motori standard. Per ottenere prestazioni superiori, quando il motore viene utilizzato con portata inferiore a 10 l/min, utilizzare versione LW (Low Leakage).
Performances data are referred to standard motors. For obtain higher performances, when the motor is used with flow < 10 l/min [< 2.64 U.S. gpm], we suggest to use LW (Low Leakage) version.

HR 400

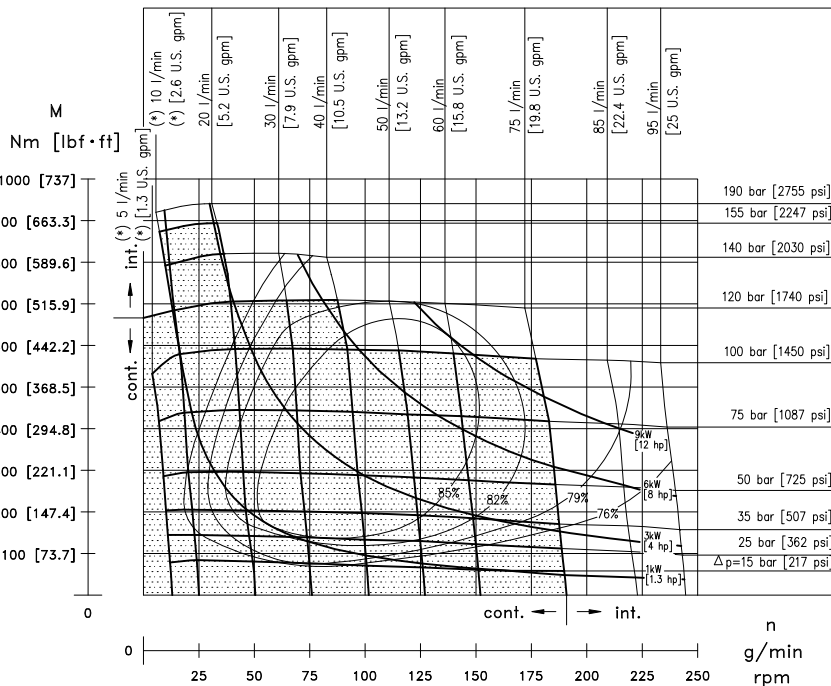

Pressioni e portate superiori a quelle ammesse in regime continuo non devono essere applicate contemporaneamente.
Exceeding continuous pressure values or exceeding flow values indicated, must not occur simultaneously.

(*) Dati prestazionali riferiti a motori standard. Per ottenere prestazioni superiori, quando il motore viene utilizzato con portata inferiore a 10 l/min, utilizzare versione LW (Low Leakage).
Performances data are referred to standard motors. For obtain higher performances, when the motor is used with flow < 10 l/min [< 2.64 U.S. gpm], we suggest to use LW (Low Leakage) version.

Informazioni sul prodotto

Dati i continui sviluppi, le modifiche e le migliorie al prodotto, la S.A.M. Hydraulik Spa non sarà responsabile per eventuali informazioni che possano indurre in errore, od erronee, riportate da cataloghi, istruzioni, disegni, dati tecnici e altri dati forniti dalla S.A.M. Hydraulik Spa. Non sarà possibile basare alcun procedimento legale su tale materiale.

Modifiche del prodotto. La S.A.M. Hydraulik Spa si riserva il diritto di variare i suoi prodotti, anche quelli già ordinati, senza notifica.

Notice

Due to the continuous product developments, modifications and improvements S.A.M. Hydraulik Spa will not be held responsible for any erroneous information or data that may lead to errors, indicated in catalogues, instructions, drawings, technical data and other data supplied by S.A.M. Hydraulik Spa. Therefore, legal actions cannot be based on such material. **Product development.** S.A.M. Hydraulik Spa reserves the right to make changes to its products, even for those already ordered, without notice.
