

BG - BH



MOTORI ORBITALI

ORBITAL MOTORS

CARATTERISTICHE DEL MOTORE MOTOR FEATURES

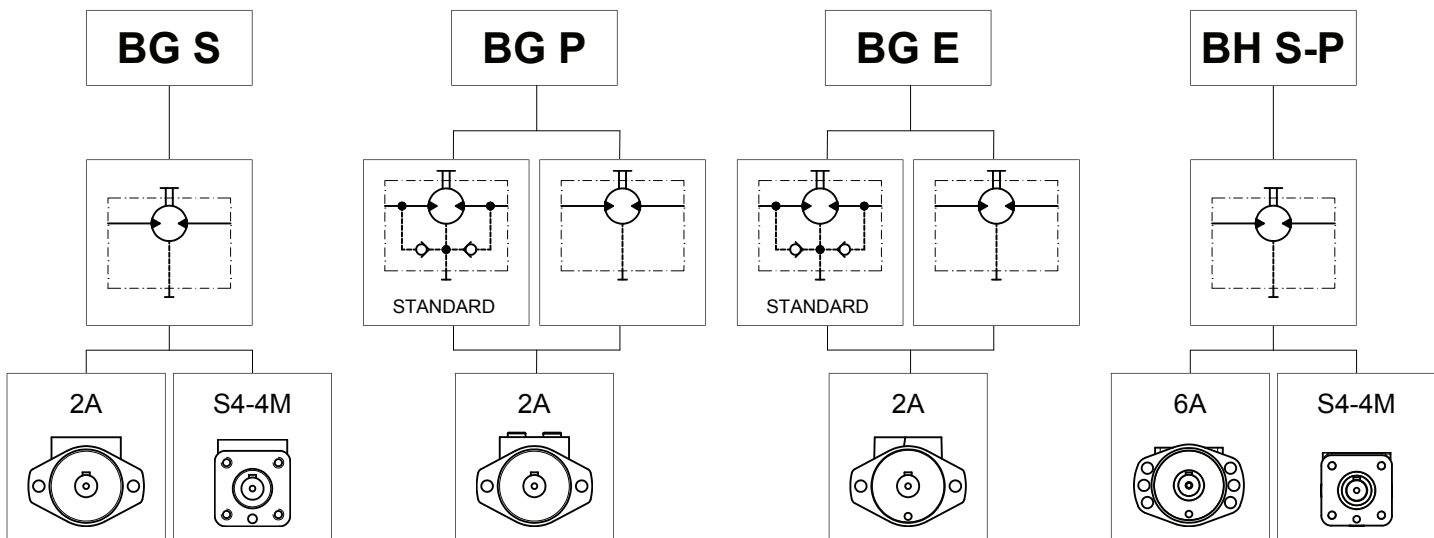

Una ampia gamma di valvole flangiabili, è disponibile su richiesta.
A wide range of flangeable valves are available on request.

Foro di drenaggio posteriore per un facile collegamento.
Rear drain port for easier connection.

Flangia a 2 e 4 fori.
2 bolts and 4 bolts mounting flange option.

Albero cilindrico $\varnothing 25$ mm e $\varnothing 25.4$ mm oppure scanalato $\varnothing 25$ mm.
0.97 in straight, 1 in straight, 0.97 in splined option.

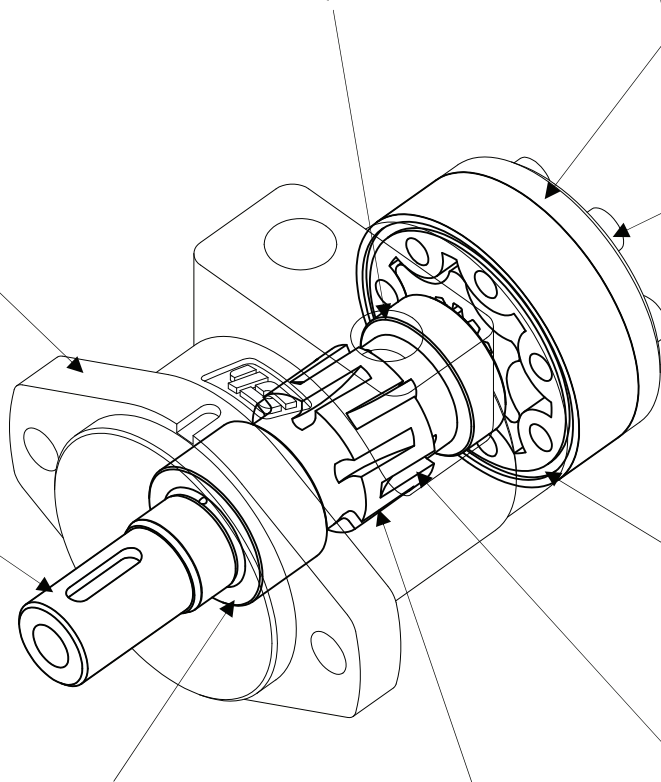

7 viti coperchio posteriore in acciaio ad alta resistenza per sopportare gli sforzi causati dall'alta pressione.
7 rear cover bolts made of high tensile steel to resist the stress caused by high pressure.

Profilo del gerotor del tipo ad alto rendimento per elevate prestazioni e durata.
High efficiency profile gerotor set.

Parapolvere per proteggere la guarnizione dell'albero dalle impurità.
Dust seal to protect the seal from dust.

Valvola di distribuzione integrata nell'albero di distribuzione. Tolleranze molto ridotte assicurano un basso drenaggio.
Spool valve integral to the output shaft featuring optimized clearance geometry and so minimizing the oil slippage.

Il profilo delle cave assicura un azionamento morbido e silenzioso anche alle velocità più basse.
Optimized grooves profile to ensure smooth and quiet running even at very low speed.

DATI TECNICI PER MOTORE BG CON ALBERI CL250-CL254
BG MOTOR TECHNICAL DATA WITH CL250-CL254 PARALLEL KEYED SHAFT

Motore Motor	Cilindrata Displacement	Pressione max ingresso Max. input pressure		Pressione diff. max. Max. differential pressure		Coppia max. Max. torque		Portata max. Max. flow		Velocità max. Max. speed		Potenza max. Max. power	
	cm ³ /rev [in ³ /rev]	bar [psi]		bar [psi]		Nm [lbf-ft]		l/min [U.S. gpm]		giri/min [rpm]		kW [hp]	
BG 050	47.8 [2.91]	Cont Int ⁽¹⁾ Peak ⁽²⁾	165 [2392] 200 [2900] 225 [3262]	Cont Int ⁽¹⁾ Peak ⁽²⁾	140 [2030] 175 [2540] 225 [3262]	Cont Int ⁽¹⁾	91 [67.1] 115 [84.7]	Cont Int ⁽¹⁾	60 [15.9] 75 [19.8]	Cont Int ⁽¹⁾	1220 1530	Cont Int ⁽¹⁾	10 [13.4] 12 [16.1]
BG 080	71.9 [4.38]	Cont Int ⁽¹⁾ Peak ⁽²⁾	165 [2392] 200 [2900] 225 [3262]	Cont Int* Peak ⁽²⁾	140 [2030] 175 [2540] 225 [3262]	Cont Int*	135 [99.5] 175 [128.9]	Cont Int ⁽¹⁾	60 [15.9] 75 [19.8]	Cont Int ⁽¹⁾	820 1025	Cont Int ⁽¹⁾	9.5 [12.7] 12 [16.1]
BG 100	100.1 [6.10]	Cont Int ⁽¹⁾ Peak ⁽²⁾	165 [2392] 200 [2900] 225 [3262]	Cont Int ⁽¹⁾ Peak ⁽²⁾	140 [2030] 175 [2540] 225 [3262]	Cont Int ⁽¹⁾	190 [140] 230 [169.5]	Cont Int ⁽¹⁾	60 [15.9] 75 [19.8]	Cont Int ⁽¹⁾	590 740	Cont Int ⁽¹⁾	10.5 [14] 13 [17.4]
BG 130	127.2 [7.76]	Cont Int ⁽¹⁾ Peak ⁽²⁾	165 [2392] 200 [2900] 225 [3262]	Cont Int ⁽¹⁾ Peak ⁽²⁾	140 [2030] 175 [2540] 225 [3262]	Cont Int ⁽¹⁾	240 [176.8] 290 [213.7]	Cont Int ⁽¹⁾	60 [15.9] 75 [19.8]	Cont Int ⁽¹⁾	465 585	Cont Int ⁽¹⁾	10 [13.4] 12 [16.1]
BG 160	165.3 [10.08]	Cont Int ⁽¹⁾ Peak ⁽²⁾	165 [2392] 200 [2900] 225 [3262]	Cont Int ⁽¹⁾ Peak ⁽²⁾	140 [2030] 175 [2540] 225 [3262]	Cont Int ⁽¹⁾	300 [221.1] 370 [272.6]	Cont Int ⁽¹⁾	60 [15.9] 75 [19.8]	Cont Int ⁽¹⁾	355 445	Cont Int ⁽¹⁾	10 [13.4] 12 [16.1]
BG 200	192.4 [11.73]	Cont Int ⁽¹⁾ Peak ⁽²⁾	165 [2392] 200 [2900] 225 [3262]	Cont Int ⁽¹⁾ Peak ⁽²⁾	115 [1670] 160 [2320] 200 [2900]	Cont Int ⁽¹⁾	300 [221.1] 390 [287.4]	Cont Int ⁽¹⁾	60 [15.9] 75 [19.8]	Cont Int ⁽¹⁾	305 380	Cont Int ⁽¹⁾	8 [10.7] 15 [20.1]
BG 250	239.1 [14.58]	Cont Int ⁽¹⁾ Peak ⁽²⁾	165 [2392] 195 [2827] 225 [3262]	Cont Int ⁽¹⁾ Peak ⁽²⁾	95 [1377] 125 [1810] 180 [2610]	Cont Int ⁽¹⁾	300 [221.1] 400 [294.8]	Cont Int ⁽¹⁾	60 [15.9] 75 [19.8]	Cont Int ⁽¹⁾	245 305	Cont Int ⁽¹⁾	6 [8.1] 8 [10.7]
BG 315	286.9 [17.50]	Cont Int ⁽¹⁾ Peak ⁽²⁾	165 [2392] 195 [2827] 225 [3262]	Cont Int ⁽¹⁾ Peak ⁽²⁾	80 [1160] 105 [1522] 160 [2320]	Cont Int ⁽¹⁾	300 [221.1] 400 [294.8]	Cont Int ⁽¹⁾	60 [15.9] 75 [19.8]	Cont Int ⁽¹⁾	205 255	Cont Int ⁽¹⁾	5 [6.7] 7 [9.4]
BG 400	382.5 [23.33]	Cont Int ⁽¹⁾ Peak ⁽²⁾	165 [2392] 195 [2827] 225 [3262]	Cont Int ⁽¹⁾ Peak ⁽²⁾	60 [870] 80 [1160] 130 [1890]	Cont Int ⁽¹⁾	300 [221.1] 400 [294.8]	Cont Int ⁽¹⁾	60 [15.9] 75 [19.8]	Cont Int ⁽¹⁾	150 190	Cont Int ⁽¹⁾	4 [5.4] 6 [8.1]

DATI TECNICI PER MOTORE BG CON ALBERO SD250
BG MOTOR TECHNICAL DATA WITH SD250 SPLINED SHAFT

Motore Tipo Motor Type	Cilindrata Displacement	Pressione max ingresso Max. input pressure		Pressione diff. max. Max. differential pressure		Coppia max. Max. torque		Portata max. Max. flow		Velocità max. Max. speed		Potenza max. Max. power	
	cm ³ /rev [in ³ /rev]	bar [psi]		bar [psi]		Nm [lbf-ft]		l/min [U.S. gpm]		giri/min [rpm]		kW [hp]	
BG 050	47.8 [2.91]	Cont Int ⁽¹⁾ Peak ⁽²⁾	165 [2392] 200 [2900] 225 [3262]	Cont Int ⁽¹⁾ Peak ⁽²⁾	140 [2030] 175 [2540] 225 [3262]	Cont Int ⁽¹⁾	91 [67.1] 115 [84.7]	Cont Int ⁽¹⁾	60 [15.9] 75 [19.8]	Cont Int ⁽¹⁾	1220 1530	Cont Int ⁽¹⁾	10 [13.4] 12 [16.1]
BG 080	71.9 [4.38]	Cont Int ⁽¹⁾ Peak ⁽²⁾	165 [2392] 200 [2900] 225 [3262]	Cont Int* Peak ⁽²⁾	140 [2030] 175 [2540] 225 [3262]	Cont Int*	135 [99.5] 175 [128.9]	Cont Int ⁽¹⁾	60 [15.9] 75 [19.8]	Cont Int ⁽¹⁾	820 1025	Cont Int ⁽¹⁾	9.5 [12.7] 12 [16.1]
BG 100	100.1 [6.10]	Cont Int ⁽¹⁾ Peak ⁽²⁾	165 [2392] 200 [2900] 225 [3262]	Cont Int ⁽¹⁾ Peak ⁽²⁾	140 [2030] 175 [2540] 225 [3262]	Cont Int ⁽¹⁾	190 [140] 230 [169.5]	Cont Int ⁽¹⁾	60 [15.9] 75 [19.8]	Cont Int ⁽¹⁾	590 740	Cont Int ⁽¹⁾	10.5 [14] 13 [17.4]
BG 130	127.2 [7.76]	Cont Int ⁽¹⁾ Peak ⁽²⁾	165 [2392] 200 [2900] 225 [3262]	Cont Int ⁽¹⁾ Peak ⁽²⁾	140 [2030] 175 [2540] 225 [3262]	Cont Int ⁽¹⁾	240 [176.8] 290 [213.7]	Cont Int ⁽¹⁾	60 [15.9] 75 [19.8]	Cont Int ⁽¹⁾	465 585	Cont Int ⁽¹⁾	10 [13.4] 12 [16.1]
BG 160	165.3 [10.08]	Cont Int ⁽¹⁾ Peak ⁽²⁾	165 [2392] 200 [2900] 225 [3262]	Cont Int ⁽¹⁾ Peak ⁽²⁾	140 [2030] 175 [2540] 225 [3262]	Cont Int ⁽¹⁾	300 [221.1] 370 [272.7]	Cont Int ⁽¹⁾	60 [15.9] 75 [19.8]	Cont Int ⁽¹⁾	355 445	Cont Int ⁽¹⁾	10 [13.4] 12 [16.1]
BG 200	192.4 [11.73]	Cont Int ⁽¹⁾ Peak ⁽²⁾	165 [2392] 200 [2900] 225 [3262]	Cont Int ⁽¹⁾ Peak ⁽²⁾	140 [2030] 175 [2540] 225 [3262]	Cont Int ⁽¹⁾	360 [265.3] 420 [309.5]	Cont Int ⁽¹⁾	60 [15.9] 75 [19.8]	Cont Int ⁽¹⁾	305 380	Cont Int ⁽¹⁾	10 [13.4] 12 [16.1]
BG 250	239.1 [14.58]	Cont Int ⁽¹⁾ Peak ⁽²⁾	165 [2392] 195 [2827] 225 [3262]	Cont Int ⁽¹⁾ Peak ⁽²⁾	110 [1595] 140 [2030] 180 [2610]	Cont Int ⁽¹⁾	360 [265.3] 440 [324.2]	Cont Int ⁽¹⁾	60 [15.9] 75 [19.8]	Cont Int ⁽¹⁾	245 305	Cont Int ⁽¹⁾	8 [10.7] 10 [13.4]
BG 315	286.9 [17.50]	Cont Int ⁽¹⁾ Peak ⁽²⁾	165 [2392] 195 [2827] 225 [3262]	Cont Int ⁽¹⁾ Peak ⁽²⁾	90 [1310] 120 [1740] 160 [2320]	Cont Int ⁽¹⁾	340 [250.6] 440 [324.2]	Cont Int ⁽¹⁾	60 [15.9] 75 [19.8]	Cont Int ⁽¹⁾	205 255	Cont Int ⁽¹⁾	5.6 [7.8] 7.5 [10.1]
BG 400	382.5 [23.33]	Cont Int ⁽¹⁾ Peak ⁽²⁾	165 [2392] 195 [2827] 225 [3262]	Cont Int ⁽¹⁾ Peak ⁽²⁾	70 [1020] 95 [1377] 130 [1890]	Cont Int ⁽¹⁾	360 [265.3] 460 [339]	Cont Int ⁽¹⁾	60 [15.9] 75 [19.8]	Cont Int ⁽¹⁾	150 190	Cont Int ⁽¹⁾	4.7 [6.3] 6 [8.1]

MOTORE MOTOR		Press.max.scar.con dren. Max return pressure with drain line bar [psi]	Press.max.avviam.a vuoto Max starting pressure with no load bar [psi]	Coppia minima di spunto Min starting torque Nm [lbf ft]		
BG	050	140 [2030]	10 [145]	A press. diff. max At max Δp	Cont. Int.	70 [51.6] 90 [66.3]
BG	080	140 [2030]	10 [145]	A press. diff. max At max Δp	Cont. Int.	105 [77.4] 135 [99.5]
BG	100	140 [2030]	10 [145]	A press. diff. max At max Δp	Cont. Int.	150 [111] 190 [140]
BG	130	140 [2030]	9 [131]	A press. diff. max At max Δp	Cont. Int.	190 [140] 240 [177]
BG	160	140 [2030]	8 [116]	A press. diff. max At max Δp	Cont. Int.	250 [184] 315 [232]
BG	200	140 [2030]	7 [102]	A press. diff. max At max Δp	Cont. Int.	255 [188] 320 [236]
BG	250	140 [2030]	6 [87]	A press. diff. max At max Δp	Cont. Int.	265 [195] 345 [254]
BG	315	140 [2030]	6 [87]	A press. diff. max At max Δp	Cont. Int.	250 [184] 330 [243]
BG	400	140 [2030]	6 [87]	A press. diff. max At max Δp	Cont. Int.	265 [195] 355 [262]

1) Le condizioni intermittenti non devono durare più del 10% di ogni minuto. Intermittent duty must not exceed 10% every minute.

2) Le condizioni di picco non devono durare più del 1% di ogni minuto. Peak duty must not exceed 1% of every minute.

3) Viscosità dell'olio 35 cSt. - Oil viscosity 35 cSt.

Pressione massima di scarico senza drenaggio o massima pressione nella linea di drenaggio. I motori sono forniti nella versione con guarnizioni standard (diagramma Standard) o nella versione con guarnizioni ad alta pressione (diagramma HPS).

Per condizioni di pressione e velocità non contemplate dal presente grafico si consiglia di contattare la Brevini Fluid Power.

N.B.: Sulla versione TAC/U non è possibile installare guarnizioni HPS.

Max. return pressure without drain line or max. pressure in the drain line.

Motor are supplied in standard seal version (Standard chart) or in HPS seal version (HPS chart).

For pressure and speeds not showed in the curve below, please contact Brevini Fluid Power.

N.B.: TAC/U version is not available with HPS seals.

STANDARD

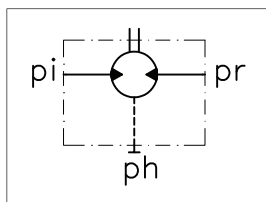
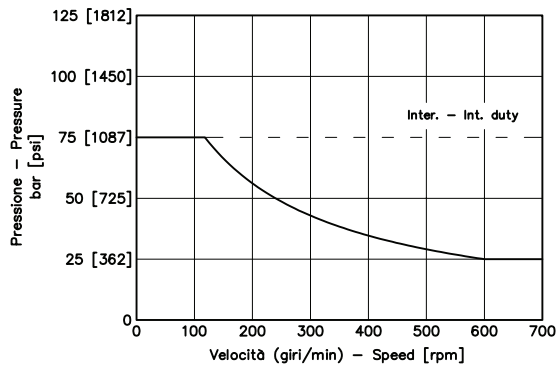

Nei motori senza le valvole interne di drenaggio, la pressione sulla guarnizione (ph) è la media tra le pressioni di alimentazione e di scarico del motore. Se ph supera il valore consentito (vedi grafici in questa pagina), occorre aprire il drenaggio.

In the motors without built-in check valves, the (ph) pressure on the seal is the average between inlet and return pressure. If ph exceeds the allowed values (see the curves in this page), the drain line must be connected.

$$Ph = \frac{pi + pr}{2} [bar]$$

ph = pressione in carcassa
 pi = pressione di alimentazione
 pr = pressione di scarico

ph = housing pressure
 pi = inlet pressure
 pr = outlet pressure

HPS

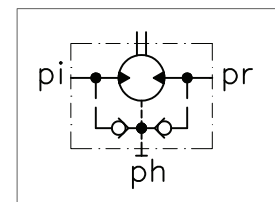
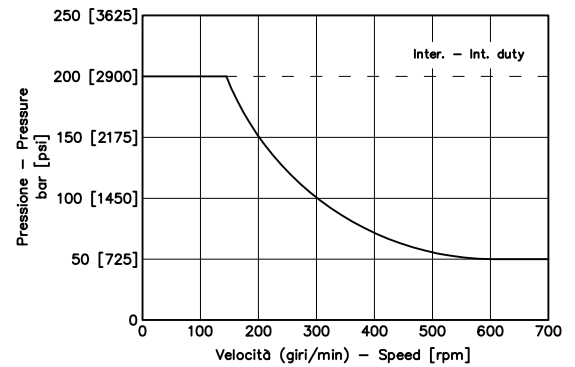

Nei motori con le valvole interne di drenaggio, la pressione sulla guarnizione (ph) è uguale alla pressione di scarico del motore. Se ph supera il valore consentito (vedi grafici in questa pagina), occorre aprire il drenaggio.

In the motors with built-in check valves, the (ph) pressure on the seal is equal to the motor return pressure. If ph exceeds the allowed values (see the curves in this page), the drain line must be connected.

CODICI DI ORDINAZIONE ORDERING CODES

Le seguenti lettere o numeri del codice, sono state sviluppate per identificare tutte le configurazioni possibili dei motori BG. Usare il seguente modulo per identificare le caratteristiche desiderate. **Tutte le lettere o numeri del codice devono comparire in fase d'ordine.** Si consiglia di leggere attentamente il catalogo prima di iniziare la compilazione del codice di ordinazione.

The following alphanumeric digits system has been developed to identify all of the configuration options for the BG motors. Use the model code below to specify the desired features. **All alphanumeric digits system of the code must be present when ordering.** We recommend to carefully read the catalogue before filling the ordering code.

CODICE PRODOTTO / MODEL CODE

1	2	3	4	5	6	7	8	8A	9	10

1 - SERIE / SERIES

BG	Motore orbitale Orbital motor
----	----------------------------------

2 - VERSIONI / VERSIONS

S	Versione S S Version	STANDARD
E	Versione E E Version	
P	Versione P P Version	

3 - CILINDRATA / DISPLACEMENT

050	47.8 cm ³ /giro [2.91 in ³ /rev]
080	73 cm ³ /giro [4.45 in ³ /rev]
100	101 cm ³ /giro [6.16 in ³ /rev]
130	126.5 cm ³ /giro [7.71 in ³ /rev]
160	165.3 cm ³ /giro [10.08 in ³ /rev]
200	192.4 cm ³ /giro [11.73 in ³ /rev]
250	239.1 cm ³ /giro [14.58 in ³ /rev]
315	286.9 cm ³ /giro [17.50 in ³ /rev]
400	382.5 cm ³ /giro [23.33 in ³ /rev]

4 - FLANGIA / MOUNTING FLANGE

		VERSIONI / VERSIONS			
		S	E	P	
2A	Ovale 2 Fori Oval 2 Bolts	STANDARD	•	•	•
S4	4 fori 3/8 16 UNC - Ø44,45mm 4 Bolt 3/8 16 UNC - Ø1.75 in		•	/	/
4M	4 fori M10 - Ø44,45mm 4 Bolt M10 - Ø1.75 in		•	/	/

• Disponibile - Available / Non Disponibile - Not Available

1	2	3	4	5	6	7	8	8A	9	10

5 - ATTACCHI / MAIN PORTS

			VERSIONI / VERSIONS		
			S	E	P
M08	Attacchi 1/2 G BSPP (40x8) 1/2 G BSPP (40x8) Main Ports	STANDARD	•	/	/
F08	Attacchi Frontali 1/2 G BSPP 1/2 G BSPP (End Main Ports)		/	/	•
R08	Attacchi 1/2 G BSPP (36x36) 1/2 G BSPP (36x36) Main Ports		/	•	/

• Disponibile - Available / Non Disponibile - Not Available

6 - ESTREMITÀ ALBERO / OUTPUT SHAFT

CL250	Albero Cilindrico Ø25 mm 0.984 in Parallel keyed	STANDARD
CL254	Albero Cilindrico Ø25.4 mm 1 in Parallel keyed	
SD250	Albero Scanalato (profilo SAE 6B 1" Z6) Splined Shaft (SAE 6B 1" 6T spline)	

7 - TENUTE / SEALS

N	NBR	STANDARD
V	FKM	Non disponibile in versione HPS (Guarnizione alta pressione) Not available in HPS (High Pressure Seal)

8 - VALVOLE / VALVES

			ATTACCHI / MAIN PORTS		
			M08	F08	R08
XXXX	Non Richieste Not Required	STANDARD	•	•	•
M081	Valvola di massima pressione VAF 08 - D VAF 08 - D pressure relief valve		•	/	/
M082	Valvola di massima pressione VAF 08 - D/AF VAF 08 - D/AF pressure relief valve		•	/	/
M083	Valvola Antiurto e Anticavitazione VAAF 31 VAAF 31 anticavitation and Anti-Shock Valve		•	/	/
M084	Valvola con prelievo del fluido in pressione AF AF shuttle-valve		•	/	/
M085	Valvola bilanciata di blocco e controllo discesa VCD 08 - S/AF VCD 08 - S/AF overcentre Valve		•	/	/
M086	Valvola di controllo bilanciata a doppio effetto VCR1 08 - D/AF VCR1 08 - D/AF double-acting overcentre valve with shuttle valve		•	/	/
M087	Valvola di controllo bilanciata a doppio effetto con valvola limitatrice di pressione VCR1 08 D/AF LDP VCR1 08 D/AF LDP double-acting overcentre valve with shuttle valve		•	/	/
R081 ⁽¹⁾	Valvola di massima pressione VAF E8 - D VAF E8 - D pressure relief valve		/	/	•
R082 ⁽¹⁾	Valvola bilanciata di blocco e controllo discesa VCD E8 - S/AF VCD E8 - S/AF overcentre Valve		/	/	•
R083 ⁽¹⁾	Valvola di controllo bilanciata a doppio effetto VCR1 E8 - D/AF VCR1 E8 - D/AF double-acting overcentre valve with shuttle valve		/	/	•
R084 ⁽¹⁾	Valvola di controllo bilanciata a doppio effetto con valvola limitatrice di pressione VCR1 E8 D/AF LDP VCR1 E8 D/AF LDP double-acting overcentre valve with shuttle valve		/	/	•

• Disponibile - Available / Non Disponibile - Not Available

(1) Attenzione: quantità minima per ordine 20 pezzi

(1) Warning: minimum quantity for order 20 pieces

1	2	3	4	5	6	7	8	8A	9	10
---	---	---	---	---	---	---	---	----	---	----

8A - CARATTERISTICA VALVOLA / VALVES FEATURE

			VALVOLE / VALVES											
			XXXX	M081	M082	M083	M084	M085	M086	M087	R081	R082	R083	R084
000	Caratteristica non necessaria Feature not necessary	STANDARD	●	/	/	/	●	/	/	/	/	/	/	/
001	Non Tarata (Campo Taratura 30+70 bar) Not Set [435 to 1015 psi]		/	●	●	/	/	/	/	/	/	/	/	/
002	Non Tarata (Campo Taratura 70+200 bar) Not Set [1015 to 2900 psi]		/	●	●	/	/	/	/	/	/	/	/	/
003	Non Tarata (Campo Taratura 50+130 bar) Not Set [725 to 1885 psi]		/	/	/	●	/	/	/	/	●	/	/	/
004	Non Tarata (Campo Taratura 100+250 bar) Not Set [1450 to 3625 psi]		/	/	/	●	/	/	/	/	/	/	/	/
006	Non Tarata (Campo Taratura 100+200 bar) Not Set [1450 to 2900 psi]		/	/	/	/	/	/	/	/	●	/	/	/
425	Rapporto di Pilotaggio 4.25:1 Pilot Ratio 4.25:1		/	/	/	/	/	/	●	●	/	/	●	●
800	Rapporto di Pilotaggio 8:1 Pilot Ratio 8:1		/	/	/	/	/	/	●	●	/	/	/	/
70D	Rapporto di Pilotaggio 7:1 - Senso di rotazione DX Pilot Ratio 7:1 - Direction of rotation CW		/	/	/	/	/	/	●	/	/	/	/	/
35D	Rapporto di Pilotaggio 3.5:1 -- Senso di rotazione DX Pilot Ratio 3.5:1 -- Direction of rotation CW		/	/	/	/	/	/	●	/	/	●	/	/
70S	Rapporto di Pilotaggio 7:1 - Senso di rotazione SX Pilot Ratio 7:1 - Direction of rotation CCW		/	/	/	/	/	/	●	/	/	/	/	/
35S	Rapporto di Pilotaggio 3.5:1 -- Senso di rotazione SX Pilot Ratio 3.5:1 -- Direction of rotation CCW		/	/	/	/	/	/	●	/	/	/	●	/

● Disponibile - Available

/ Non Disponibile - Not Available

Per la fornitura di valvole tarate contattare Uff. Tecnico.

Please contact Technical department for valve which require specific setting

9 - CARATTERISTICA VERSIONE / VERSION FEATURE

			VERSIONI / VERSIONS		
			S	E	P
XXX	Versione base + Drenaggio posteriore - 1/4 G (BSPP) Standard version + Rear Drain - 1/4 G (BSPP)	STANDARD	●	●	●
HPS	Guarnizione alta pressione (senza Drenaggio posteriore) High Pressure Seal (without Rear Drain)		●	●	●
TC1	Tachimetro TAC/U (con predisposizione per sensore) TAC/U tachometer (with sensor arrangement)		●	/	/
SV0	Versione senza valvole di drenaggio interne + Drenaggio posteriore - 1/4 G (BSPP) Version without built-in check valves + Rear Drain - 1/4 G (BSPP)		/	●	●
SVH	Versione senza valvole di drenaggio interne + Guarnizione alta pressione (senza Drenaggio posteriore) Version without built-in check valves + High Pressure Seal (without Rear Drain)		/	●	●
SVA	Versione senza valvole di drenaggio interne + Guarnizione alta pressione + Drenaggio posteriore - 1/4 G (BSPP) Version without built-in check valves + High Pressure Seal + Rear Drain - 1/4 G (BSPP)		/	●	/
DPH	Guarnizione alta pressione + Drenaggio posteriore - 1/4 G (BSPP) High Pressure Seal + Rear Drain - 1/4 G (BSPP)		●	●	/

● Disponibile - Available

/ Non Disponibile - Not Available

10 - OPZIONI / OPTIONS

XX	Non verniciato Not Painted	STANDARD
01	Verniciato Nero RAL 9005 Black Painted RAL 9005	
02	Verniciato Blu RAL 5015 Blue Painted RAL 5015	
06	Verniciato Grigio RAL 7015 Grey Painted RAL 7015	
07	Verniciato Grigio RAL 7021 Grey Painted RAL 7021	

Flangia 2A Flange
Attacchi M08 Main ports

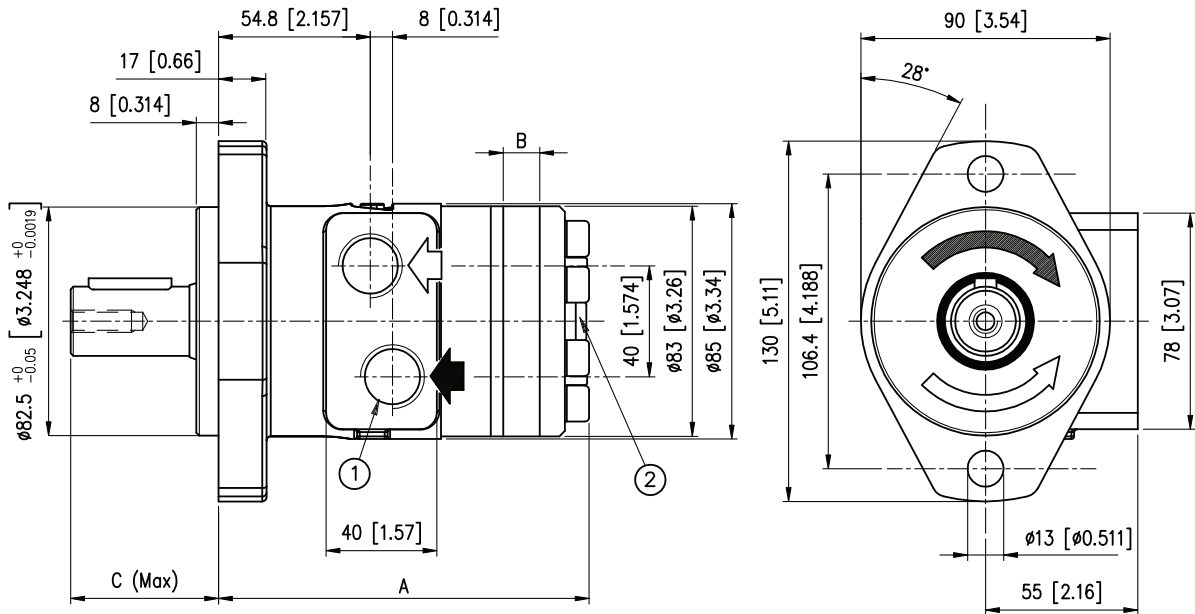

- 1) N° 2 fori di alimentazione 1/2 G (BSPP) profondità filetto 18 mm
No. 2 1/2 G (BSPP) main ports thread depth 0.70 in
- 2) Drenaggio motore 1/4 G (BSPP) profondità filetto 12 mm
1/4 G (BSPP) drain motor thread depth 0.472 in

Per le dimensioni degli alberi vedere pagina C/14
For shafts dimensions see page C/14

ALBERO SHAFT		CL250	CL254	SD250						
C	mm [in]	53.5 [2.10]	53.5 [2.10]	53.5 [2.10]						

		BG S 050	BG S 080	BG S 100	BG S 130	BG S 160	BG S 200	BG S 250	BG S 315	BG S 400
A	mm [in]	127.5 [5.01]	130.5 [5.13]	134.5 [5.29]	138.5 [5.45]	143.5 [5.64]	146.5 [5.76]	153.5 [6.04]	162.5 [6.39]	172.5 [6.79]
B	mm [in]	6.3 [0.248]	9.5 [0.374]	13.3 [0.523]	16.2 [0.63]	21.9 [0.86]	25.5 [1.003]	31.7 [1.24]	38.1 [1.50]	50.8 [2.00]
Peso - Weight	kg [lb]	5.5 [12.1]	5.6 [12.3]	5.8 [12.8]	5.9 [13.0]	6.1 [13.4]	6.3 [13.9]	6.5 [14.3]	6.8 [15.0]	7.3 [16.1]

Flangia S4 - 4M Flange
Attacchi M08 Main ports

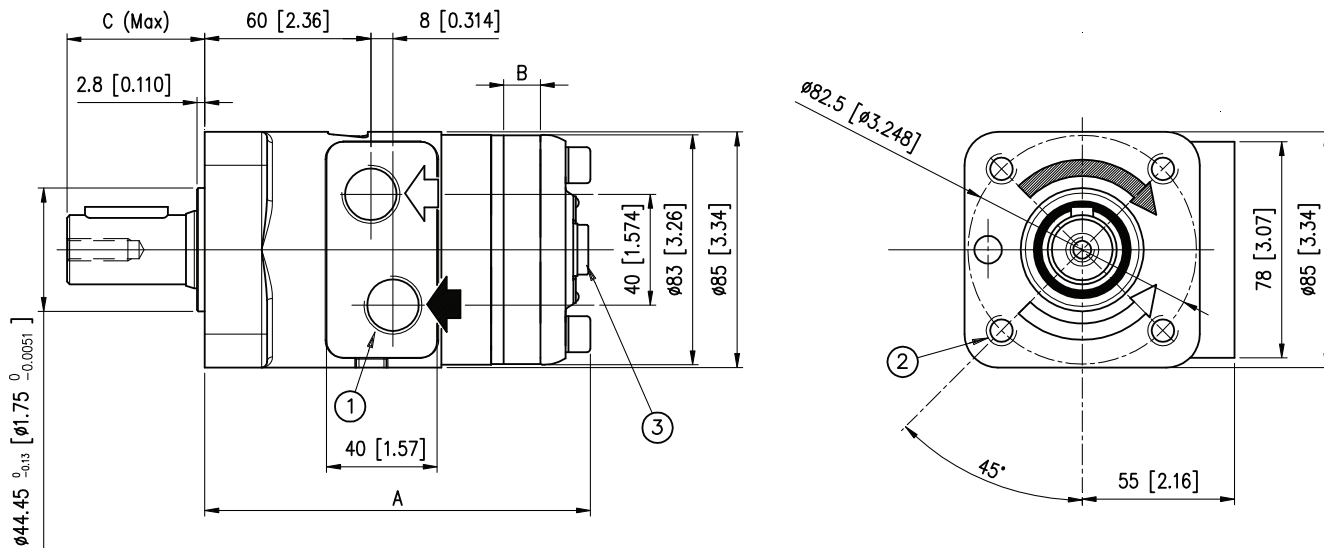

- 1) N° 2 fori di alimentazione 1/2 G (BSPP) profondità filetto 18 mm
No. 2 1/2 G (BSPP) main ports thread depth 0.70 in
- 2) N° 4 3/8 16UNC profondità filetto 17 mm (Flangia S4)
No. 4 3/8 16UNC thread depth 0.66 in (S4 flange)
N° 4 M10 profondità filetto 17 mm (Flangia 4M)
No. 4 M10 thread depth 0.66 in (4M flange)
- 3) Drenaggio motore 1/4 G (BSPP) profondità filetto 12 mm
1/4 G (BSPP) drain motor thread depth 0.472 in

Per le dimensioni degli alberi vedere pagina C/14
For shafts dimensions see page C/14

ALBERO SHAFT		CL250	CL254	SD250						
C	mm [in]	50 [1.96]	45 [1.77]	50 [1.96]						

		BG S 050	BG S 080	BG S 100	BG S 130	BG S 160	BG S 200	BG S 250	BG S 315	BG S 400
A	mm [in]	133.1 [5.24]	136.3 [5.36]	140 [5.51]	143.7 [5.65]	148.7 [5.85]	152.2 [5.99]	158.5 [6.24]	165 [6.49]	177.5 [6.98]
B	mm [in]	6.3 [0.248]	9.5 [0.374]	13.3 [0.523]	16.2 [0.63]	21.9 [0.86]	25.5 [1.003]	31.7 [1.24]	38.1 [1.50]	50.8 [2.00]
Peso - Weight	kg [lb]	5.5 [12.1]	5.6 [12.3]	5.8 [12.8]	5.9 [13.0]	6.1 [13.4]	6.3 [13.9]	6.5 [14.3]	6.8 [15.0]	7.3 [16.1]

Flangia 2A Flange
Attacchi F08 Main ports

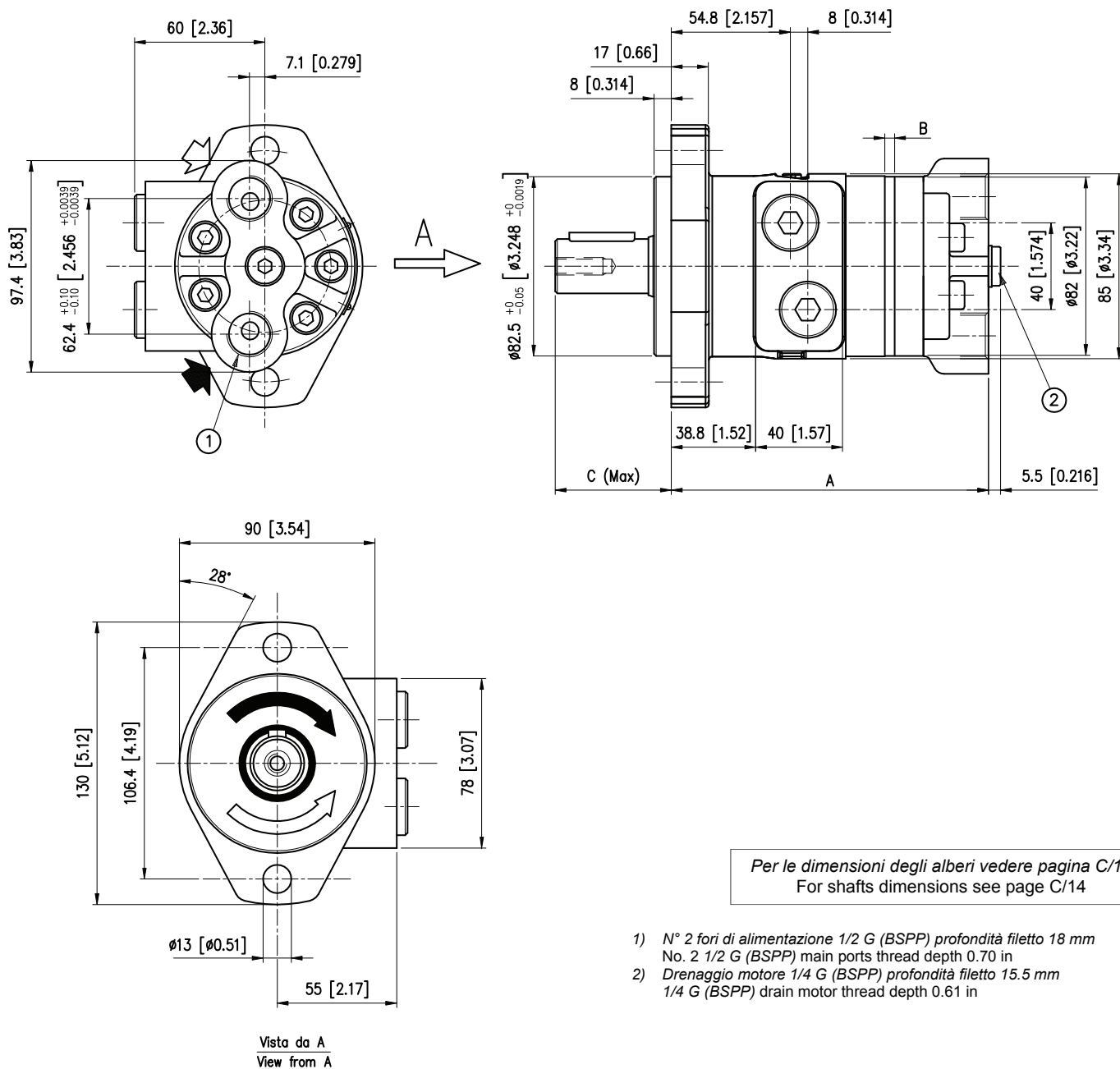

Per le dimensioni degli alberi vedere pagina C/14
For shafts dimensions see page C/14

- 1) N° 2 fori di alimentazione 1/2 G (BSPP) profondità filetto 18 mm
No. 2 1/2 G (BSPP) main ports thread depth 0.70 in
- 2) Drenaggio motore 1/4 G (BSPP) profondità filetto 15.5 mm
1/4 G (BSPP) drain motor thread depth 0.61 in

ALBERO SHAFT		CL250	CL254	SD250						
C	mm [in]	53.5 [2.10]	53.5 [2.10]	53.5 [2.10]						
		BG P 050	BG P 080	BG P 100	BG P 130	BG P 160	BG P 200	BG P 250	BG P 315	BG P 400
A	mm [in]	140 [5.51]	143 [5.62]	147 [5.78]	150.2 [5.91]	155.5 [6.12]	159 [6.25]	165 [6.49]	171.5 [6.75]	187.5 [7.38]
B	mm [in]	6.3 [0.248]	9.5 [0.374]	13.3 [0.523]	16.2 [0.63]	21.9 [0.86]	25.5 [1.003]	31.7 [1.24]	38.1 [1.50]	50.8 [2.00]
Peso - Weight	kg [lb]	6.5 [14.3]	6.6 [14.5]	6.8 [15.0]	6.9 [15.2]	7.1 [15.6]	7.3 [16.1]	7.5 [16.5]	7.8 [17.2]	8.3 [18.3]

Flangia 2A Flange
Attacchi R08 Main ports

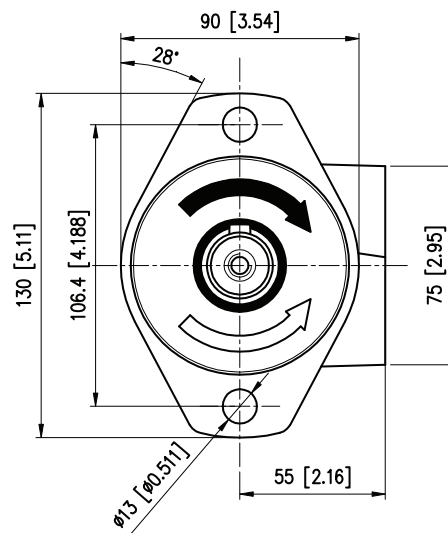
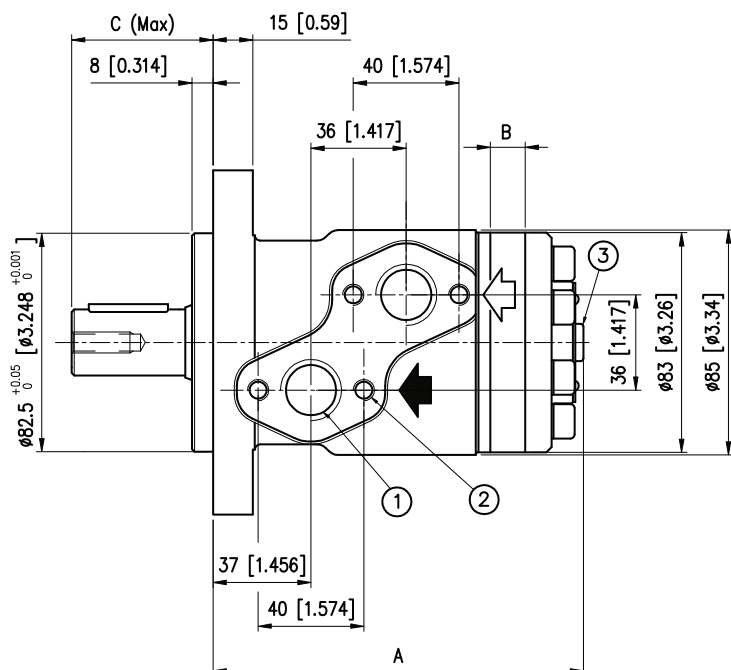

- 1) N° 2 fori di alimentazione 1/2 G (BSPP) profondità filetto 18 mm
No. 2 1/2 G (BSPP) main ports thread depth 0.70 in
- 2) N° 4 fori M8 tratto utile filetto 16 mm
No. 4 M8 thread depth 0.62 in
- 3) Drenaggio motore 1/4 G (BSPP) profondità filetto 12 mm
1/4 G (BSPP) drain motor thread depth 0.472 in

Per le dimensioni degli alberi vedere pagina C/14
For shafts dimensions see page C/14

ALBERO SHAFT		CL250	CL254	SD250						
C	mm [in]	55 [2.16]	50 [1.96]	55 [2.16]						
		BG E 050	BG E 080	BG E 100	BG E 130	BG E 160	BG E 200	BG E 250	BG E 315	BG E 400
A	mm [in]	127.7 [5.03]	130.9 [5.15]	134.7 [5.30]	138.2 [5.44]	143.3 [5.64]	146.9 [5.78]	153.1 [6.02]	159.5 [6.27]	172.2 [6.78]
B	mm [in]	6.3 [0.248]	9.5 [0.374]	13.3 [0.523]	16.2 [0.63]	21.9 [0.86]	25.5 [1.003]	31.7 [1.24]	38.1 [1.50]	50.8 [2.00]
Peso - Weight	kg [lb]	5.5 [12.1]	5.6 [12.3]	5.8 [12.8]	5.9 [13.0]	6.1 [13.4]	6.3 [13.9]	6.5 [14.3]	6.8 [15.0]	7.3 [16.1]

- 1) Drenaggio motore 1/4 G (BSPP) profondità filetto 12mm
1/4 G (BSPP) drain motor thread depth 0.472 in
- 2) Attacco sensore M8x1
Sensor connection M8x1

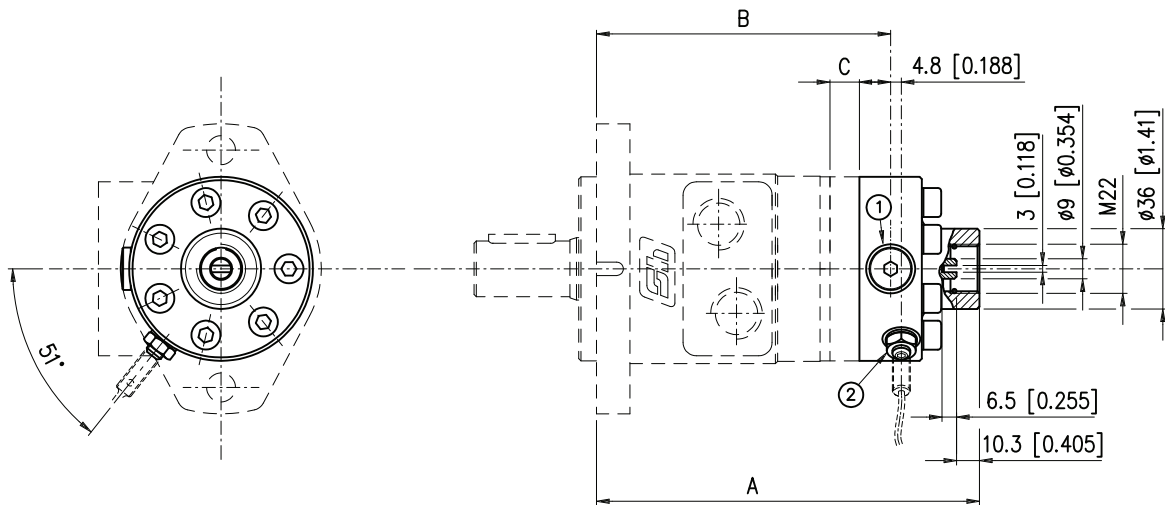

ATTENZIONE:

- L'alberino contagiri ha velocità pari a 6 volte quella dell'albero primario del motore e senso di rotazione opposto.
- N.B. Non sono accettati carichi assiali o radiali sull'albero contagiri. Coppia massima trasmissibile 1Nm.
- Il motore viene fornito senza il sensore elettronico: se necessario, richiederlo in fase di ordinazione.
- Pressione massima ammessa sulla guarnizione dell'albero contagiri con drenaggio chiuso: 25 bar.

WARNING:

- Tacho shaft has a 6 times higher revolution speed than the motor shaft and opposite direction of rotation.
- NOTE: Axial or radial load on tacho shaft must be avoided. Max torque on tacho 1 Nm [0.73 lbf-ft].
- The electronic sensor is not supplied: if required, please state it clearly on order form.
- Max pressure admissible on the shaft seal with closed drain port 25 bar [363 psi].

		BG S 050	BG S 080	BG S 100	BG S 130	BG S 160	BG S 200	BG S 250	BG S 315	BG S 400
A	mm [in]	163 [6.41]	166 [6.53]	170 [6.69]	174 [6.85]	179 [7.04]	182 [7.16]	189 [7.44]	195 [7.67]	208 [8.18]
B	mm [in]	123 [4.84]	126 [4.96]	130 [5.11]	134 [5.27]	139 [5.47]	142 [5.59]	149 [5.86]	155 [6.10]	168 [6.61]
C	mm [in]	6.3 [0.248]	9.5 [0.374]	13.3 [0.523]	16.2 [0.63]	21.9 [0.86]	25.5 [1.003]	31.7 [1.24]	38.1 [1.50]	50.8 [2.00]
Peso - Weight	kg [lb]	6 [13.2]	6.1 [13.4]	6.3 [13.9]	6.4 [14.1]	6.6 [14.5]	6.8 [15.0]	7.0 [15.4]	7.3 [16.1]	7.8 [17.2]

CARATTERISTICHE TECNICHE DEL SENSORE ELETTRONICO
ELECTRONIC SENSOR TECHNICAL FEATURES

Segnale in uscita versione elettronica
Output signal electronic tacho

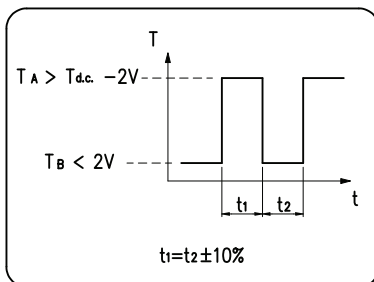

Numero d'impulsi per giro = 90
Principio di funzionamento induttivo
Funzione di uscita PNP
Tensione nominale 10-65 V d.c.
Caricabilità massima 300 mA
Frequenza massima 10000 Hz
Campo di temperatura -25C +85C
Grado di protezione IP 67

Versioni disponibili:

- Sensore con cavo a tre fili lunghezza 2 metri (cod.424.0050.0000)
- Sensore con attacco per connettore tipo binder (cod.424.0060.0000) + connettore tipo binder
- con cavo a tre fili lunghezza 5 metri (cod.424.0080.0000)

Number of pulses per revolution = 90
Inductive principle
Output current PNP
Voltage 10-65 V d.c.
Max load 300 mA
Max frequency 10000 Hz
Temperature range -25C +85C
Enclosure IP 67

Available versions:

- Sensor with 2 metres three wires cable (cod.424.0050.0000)
- Sensor with binder plug connection (cod.424.0060.0000) + binder connecting
- plug with 5 metres three wires cable (cod.424.0080.0000)

**ALBERO CILINDRICO CL250
CL250 CYLINDRICAL SHAFT**

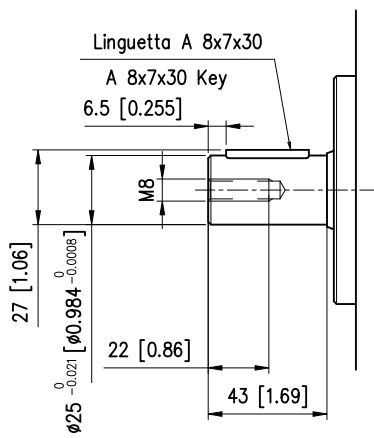

**ALBERO CILINDRICO CL254
CL254 CYLINDRICAL SHAFT**

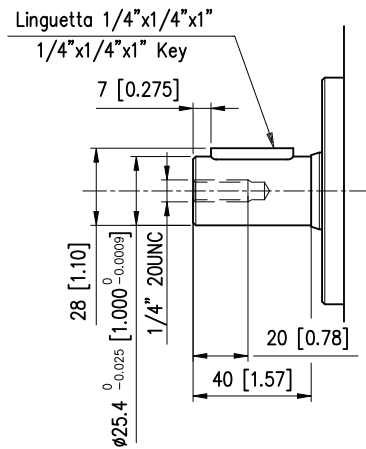

**ALBERO SCANALATO SD250
SD250 SPLINED SHAFT**

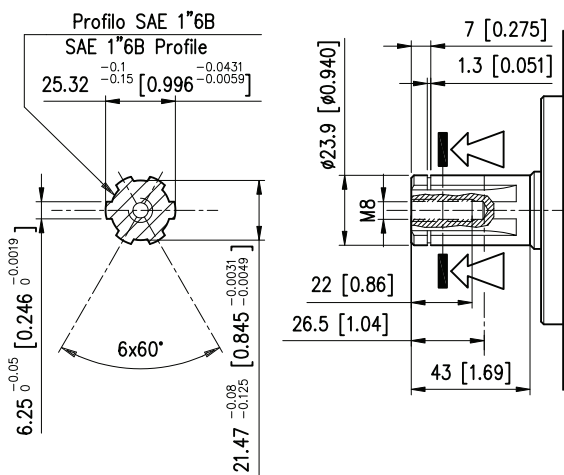

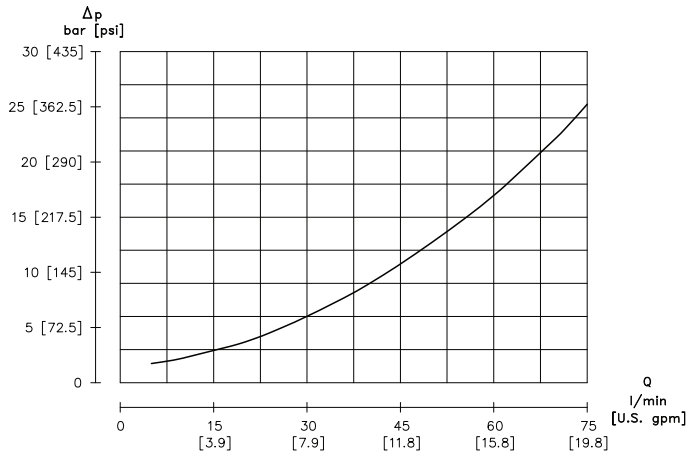

Il diagramma è stato ottenuto con prove eseguite su un numero significativo di motori, utilizzando un'olio avente una viscosità cinematica di 37 cSt alla temperatura di 45° C.

Diagram according to tests done with a huge number of motors and using hydraulic oil with kinematic viscosity of 37 cSt at 45° C temperature.

CARICHI AMMESSI SULL'ALBERO SHAFT LOAD CAPACITY

I carichi ammessi sull'albero variano in funzione di:

- Velocità (n)
- Distanza (L) dal punto di applicazione del carico alla flangia di montaggio
- Versione della flangia di montaggio

Formula utilizzabile per il calcolo del carico radiale (Pr) ai vari numeri di giri (n), e alle varie distanze (L) dalla flangia tipo "2A" ovale 2 fori.

Radial load capacity (Pr) curve according to speed (n) and distance (L) from flange, valid for the 2-bolt flange type "2A"

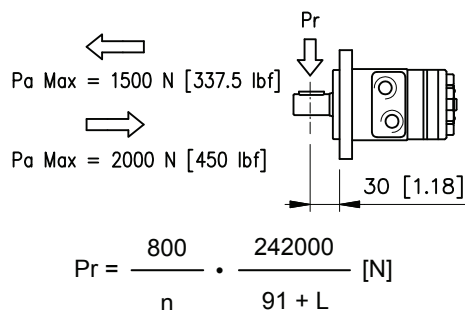

Formula valida per n ≥ 200 rpm
Per n < 200 rpm Prmax = 8000 N

This formula being valid for n ≥ 200 rpm
For n < 200 rpm Prmax = 8000 N [1800 lbf]

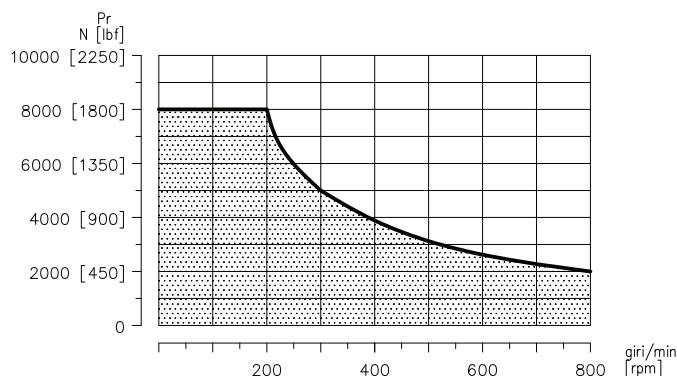

La curva mostra la relazione tra (Pr) e (n) quando:

- L = 30 mm [1.18 in] per motori flangia 2A
- L = 24 mm [0.95 in] per motori flangia S4-4M

The permissible radial shaft load depends on

- Speed (n)
- Distance (L) from the point of load to the mounting flange
- Mounting flange version

Formula utilizzabile per il calcolo del carico radiale (Pr) ai vari numeri di giri (n), e alle varie distanze (L) dalla flangia tipo "S4-4M" 4 fori.

Radial load capacity (Pr) curve according to speed (n) and distance (L) from flange, valid for the 4-bolt flange type "S4-4M".

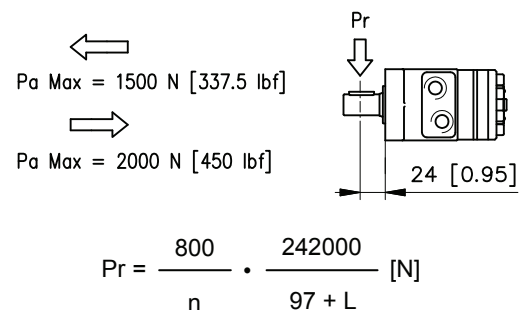

Formula valida per n ≥ 200 rpm
Per n < 200 rpm Prmax = 8000 N

This formula being valid for n ≥ 200 rpm
For n < 200 rpm Prmax = 8000 N [1800 lbf]

The curve shows the relation between (Pr) and (n)

- L = 30 mm [1.18 in] for motors with 2A flange
- L = 24 mm [0.95 in] for motors with S4-4M flange

DATI TECNICI PER MOTORE BH CON ALBERO CL254-CS254-CL250 / BH MOTOR TECHNICAL DATA WITH CL254-CS254-CL250 SHAFT

Motore Motor	Cilindrata Displacement	Pressione max ingresso Max. input pressure		Pressione diff. max. Max. differential pressure		Coppia max. Max. torque		Portata max. Max. flow		Velocità max. Max. speed		Potenza max. Max. power	
	cm ³ /rev [in ³ /rev]	bar [psi]		bar [psi]		Nm [lbf-ft]		l/min [U.S. gpm]		giri/min [rpm]		kW [hp]	
BH 050	47.8 [2.91]	Cont	165 [2392]	Cont	140 [2030]	Cont	91 [67.1]	Cont	60 [15.9]	Cont	1220	Cont	10 [13.4]
		Int ¹⁾	200 [2900]	Int ¹⁾	175 [2540]	Int ¹⁾	115 [84.7]	Int ¹⁾	75 [19.8]	Int ¹⁾	1530	Int ¹⁾	12 [16.1]
		Peak ²⁾	225 [3262]	Peak ²⁾	225 [3262]	Peak ²⁾	225 [3262]	Peak ²⁾	225 [3262]	Peak ²⁾	225 [3262]	Peak ²⁾	225 [3262]
BH 080	71.9 [4.38]	Cont	165 [2392]	Cont	140 [2030]	Cont	135 [99.5]	Cont	60 [15.9]	Cont	820	Cont	9.5 [12.7]
		Int ¹⁾	200 [2900]	Int* ¹⁾	175 [2540]	Int* ¹⁾	175 [128.9]	Int ¹⁾	75 [19.8]	Int ¹⁾	1025	Int ¹⁾	12 [16.1]
		Peak ²⁾	225 [3262]	Peak ²⁾	225 [3262]	Peak ²⁾	225 [3262]	Peak ²⁾	225 [3262]	Peak ²⁾	225 [3262]	Peak ²⁾	225 [3262]
BH 100	100.1 [6.10]	Cont	165 [2392]	Cont	140 [2030]	Cont	190 [140]	Cont	60 [15.9]	Cont	590	Cont	10.5 [14]
		Int ¹⁾	200 [2900]	Int ¹⁾	175 [2540]	Int ¹⁾	230 [169.5]	Int ¹⁾	75 [19.8]	Int ¹⁾	740	Int ¹⁾	13 [17.4]
		Peak ²⁾	225 [3262]	Peak ²⁾	225 [3262]	Peak ²⁾	225 [3262]	Peak ²⁾	225 [3262]	Peak ²⁾	225 [3262]	Peak ²⁾	225 [3262]
BH 130	127.2 [7.76]	Cont	165 [2392]	Cont	140 [2030]	Cont	240 [176.8]	Cont	60 [15.9]	Cont	465	Cont	10 [13.4]
		Int ¹⁾	200 [2900]	Int ¹⁾	175 [2540]	Int ¹⁾	290 [213.7]	Int ¹⁾	75 [19.8]	Int ¹⁾	585	Int ¹⁾	12 [16.1]
		Peak ²⁾	225 [3262]	Peak ²⁾	225 [3262]	Peak ²⁾	225 [3262]	Peak ²⁾	225 [3262]	Peak ²⁾	225 [3262]	Peak ²⁾	225 [3262]
BH 160	165.3 [10.08]	Cont	165 [2392]	Cont	140 [2030]	Cont	300 [221.1]	Cont	60 [15.9]	Cont	355	Cont	10 [13.4]
		Int ¹⁾	200 [2900]	Int ¹⁾	175 [2540]	Int ¹⁾	370 [272.6]	Int ¹⁾	75 [19.8]	Int ¹⁾	445	Int ¹⁾	12 [16.1]
		Peak ²⁾	225 [3262]	Peak ²⁾	225 [3262]	Peak ²⁾	225 [3262]	Peak ²⁾	225 [3262]	Peak ²⁾	225 [3262]	Peak ²⁾	225 [3262]
BH 200	192.4 [11.73]	Cont	165 [2392]	Cont	115 [1670]	Cont	300 [221.1]	Cont	60 [15.9]	Cont	305	Cont	8 [10.7]
		Int ¹⁾	200 [2900]	Int ¹⁾	160 [2320]	Int ¹⁾	390 [287.4]	Int ¹⁾	75 [19.8]	Int ¹⁾	380	Int ¹⁾	15 [20.1]
		Peak ²⁾	225 [3262]	Peak ²⁾	200 [2900]	Peak ²⁾	200 [2900]	Peak ²⁾	200 [2900]	Peak ²⁾	200 [2900]	Peak ²⁾	200 [2900]
BH 250	239.1 [14.58]	Cont	165 [2392]	Cont	95 [1377]	Cont	300 [221.1]	Cont	60 [15.9]	Cont	245	Cont	6 [8.1]
		Int ¹⁾	195 [2827]	Int ¹⁾	125 [1810]	Int ¹⁾	400 [294.8]	Int ¹⁾	75 [19.8]	Int ¹⁾	305	Int ¹⁾	8 [10.7]
		Peak ²⁾	225 [3262]	Peak ²⁾	180 [2610]	Peak ²⁾	180 [2610]	Peak ²⁾	180 [2610]	Peak ²⁾	180 [2610]	Peak ²⁾	180 [2610]
BH 315	286.9 [17.50]	Cont	165 [2392]	Cont	80 [1160]	Cont	300 [221.1]	Cont	60 [15.9]	Cont	205	Cont	5 [6.7]
		Int ¹⁾	195 [2827]	Int ¹⁾	105 [1522]	Int ¹⁾	400 [294.8]	Int ¹⁾	75 [19.8]	Int ¹⁾	255	Int ¹⁾	7 [9.4]
		Peak ²⁾	225 [3262]	Peak ²⁾	160 [2320]	Peak ²⁾	160 [2320]	Peak ²⁾	160 [2320]	Peak ²⁾	160 [2320]	Peak ²⁾	160 [2320]
BH 400	382.5 [23.33]	Cont	165 [2392]	Cont	60 [870]	Cont	300 [221.1]	Cont	60 [15.9]	Cont	150	Cont	4 [5.4]
		Int ¹⁾	195 [2827]	Int ¹⁾	80 [1160]	Int ¹⁾	400 [294.8]	Int ¹⁾	75 [19.8]	Int ¹⁾	190	Int ¹⁾	6 [8.1]
		Peak ²⁾	225 [3262]	Peak ²⁾	130 [1890]	Peak ²⁾	130 [1890]	Peak ²⁾	130 [1890]	Peak ²⁾	130 [1890]	Peak ²⁾	130 [1890]

DATI TECNICI PER MOTORE BH CON ALBERO SE250 / BH MOTOR TECHNICAL DATA WITH SE250 SHAFT

Motore Motor	Cilindrata Displacement	Pressione max ingresso Max. input pressure		Pressione diff. max. Max. differential pressure		Coppia max. Max. torque		Portata max. Max. flow		Velocità max. Max. speed		Potenza max. Max. power	
	cm ³ /rev [in ³ /rev]	bar [psi]		bar [psi]		Nm [lbf-ft]		l/min [U.S. gpm]		giri/min [rpm]		kW [hp]	
BH 050	47.8 [2.91]	Cont	165 [2392]	Cont	140 [2030]	Cont	91 [67.1]	Cont	60 [15.9]	Cont	1220	Cont	10 [13.4]
		Int ¹⁾	200 [2900]	Int ¹⁾	175 [2540]	Int ¹⁾	115 [84.7]	Int ¹⁾	75 [19.8]	Int ¹⁾	1530	Int ¹⁾	12 [16.1]
		Peak ²⁾	225 [3262]	Peak ²⁾	225 [3262]	Peak ²⁾	225 [3262]	Peak ²⁾	225 [3262]	Peak ²⁾	225 [3262]	Peak ²⁾	225 [3262]
BH 080	71.9 [4.38]	Cont	165 [2392]	Cont	140 [2030]	Cont	135 [99.5]	Cont	60 [15.9]	Cont	820	Cont	9.5 [12.7]
		Int ¹⁾	200 [2900]	Int* ¹⁾	175 [2540]	Int* ¹⁾	175 [128.9]	Int ¹⁾	75 [19.8]	Int ¹⁾	1025	Int ¹⁾	12 [16.1]
		Peak ²⁾	225 [3262]	Peak ²⁾	225 [3262]	Peak ²⁾	225 [3262]	Peak ²⁾	225 [3262]	Peak ²⁾	225 [3262]	Peak ²⁾	225 [3262]
BH 100	100.1 [6.10]	Cont	165 [2392]	Cont	140 [2030]	Cont	190 [140]	Cont	60 [15.9]	Cont	590	Cont	10.5 [14]
		Int ¹⁾	200 [2900]	Int ¹⁾	175 [2540]	Int ¹⁾	230 [169.5]	Int ¹⁾	75 [19.8]	Int ¹⁾	740	Int ¹⁾	13 [17.4]
		Peak ²⁾	225 [3262]	Peak ²⁾	225 [3262]	Peak ²⁾	225 [3262]	Peak ²⁾	225 [3262]	Peak ²⁾	225 [3262]	Peak ²⁾	225 [3262]
BH 130	127.2 [7.76]	Cont	165 [2392]	Cont	140 [2030]	Cont	240 [176.8]	Cont	60 [15.9]	Cont	465	Cont	10 [13.4]
		Int ¹⁾	200 [2900]	Int ¹⁾	175 [2540]	Int ¹⁾	290 [213.7]	Int ¹⁾	75 [19.8]	Int ¹⁾	585	Int ¹⁾	12 [16.1]
		Peak ²⁾	225 [3262]	Peak ²⁾	225 [3262]	Peak ²⁾	225 [3262]	Peak ²⁾	225 [3262]	Peak ²⁾	225 [3262]	Peak ²⁾	225 [3262]
BH 160	165.3 [10.08]	Cont	165 [2392]	Cont	140 [2030]	Cont	300 [221.1]	Cont	60 [15.9]	Cont	355	Cont	10 [13.4]
		Int ¹⁾	200 [2900]	Int ¹⁾	175 [2540]	Int ¹⁾	370 [272.7]	Int ¹⁾	75 [19.8]	Int ¹⁾	445	Int ¹⁾	12 [16.1]
		Peak ²⁾	225 [3262]	Peak ²⁾	225 [3262]	Peak ²⁾	225 [3262]	Peak ²⁾	225 [3262]	Peak ²⁾	225 [3262]	Peak ²⁾	225 [3262]
BH 200	192.4 [11.73]	Cont	165 [2392]	Cont	140 [2030]	Cont	360 [265.3]	Cont	60 [15.9]	Cont	305	Cont	10 [13.4]
		Int ¹⁾	200 [2900]	Int ¹⁾	175 [2540]	Int ¹⁾	420 [309.5]	Int ¹⁾	75 [19.8]	Int ¹⁾	380	Int ¹⁾	12 [16.1]
		Peak ²⁾	225 [3262]	Peak ²⁾	225 [3262]	Peak ²⁾	225 [3262]	Peak ²⁾	225 [3262]	Peak ²⁾	225 [3262]	Peak ²⁾	225 [3262]
BH 250	239.1 [14.58]	Cont	165 [2392]	Cont	110 [1595]	Cont	360 [265.3]	Cont	60 [15.9]	Cont	245	Cont	8 [10.7]
		Int ¹⁾	195 [2827]	Int ¹⁾	140 [2030]	Int ¹⁾	440 [324.2]	Int ¹⁾	75 [19.8]	Int ¹⁾	305	Int ¹⁾	10 [13.4]
		Peak ²⁾	225 [3262]	Peak ²⁾	180 [2610]	Peak ²⁾	180 [2610]	Peak ²⁾	180 [2610]	Peak ²⁾	180 [2610]	Peak ²⁾	180 [2610]
BH 315	286.9 [17.50]	Cont	165 [2392]	Cont	90 [1310]	Cont	340 [250.6]	Cont	60 [15.9]	Cont	205	Cont	5.6 [7.8]
		Int ¹⁾	195 [2827]	Int ¹⁾	120 [1740]	Int ¹⁾	440 [324.2]	Int ¹⁾	75 [19.8]	Int ¹⁾	255	Int ¹⁾	7.5 [10.1]
		Peak ²⁾	225 [3262]	Peak ²⁾	160 [2320]	Peak ²⁾	160 [2320]	Peak ²⁾	160 [2320]	Peak ²⁾	160 [2320]	Peak ²⁾	160 [2320]
BH 400	382.5 [23.33]	Cont	165 [2392]	Cont	70 [1020]	Cont	360 [265.3]	Cont	60 [15.9]	Cont	150	Cont	4.7 [6.3]
		Int ¹⁾	195 [2827]	Int ¹⁾	95 [1377]	Int ¹⁾	460 [339]	Int ¹⁾	75 [19.8]	Int ¹⁾	190	Int ¹⁾	6 [8.1]
		Peak ²⁾	225 [3262]	Peak ²⁾	130 [1890]	Peak ²⁾	130 [1890]	Peak ²⁾	130 [1890]	Peak ²⁾	130 [1890]	Peak ²⁾	130 [1890]

1) Le condizioni intermittenti non devono durare più del 10% di ogni minuto. Intermittent duty must not exceed 10% every minute.

2) Le condizioni di picco non devono durare più del 1% di ogni minuto. Peak duty must not exceed 1% of every minute.

Pressione massima di scarico senza drenaggio o massima pressione nella linea di drenaggio. I motori sono forniti nella versione con guarnizioni standard (diagramma Standard) o nella versione con guarnizioni ad alta pressione (diagramma HPS).

Per condizioni di pressione e velocità non contemplate dal presente grafico si consiglia di contattare la Brevini Fluid Power.

Max. return pressure without drain line or max. pressure in the drain line.

Motor are supplied in standard seal version (Standard chart) or in HPS seal version (HPS chart).

For pressure and speeds not showed in the curve below, please contact Brevini Fluid Power.

STANDARD (QDR)

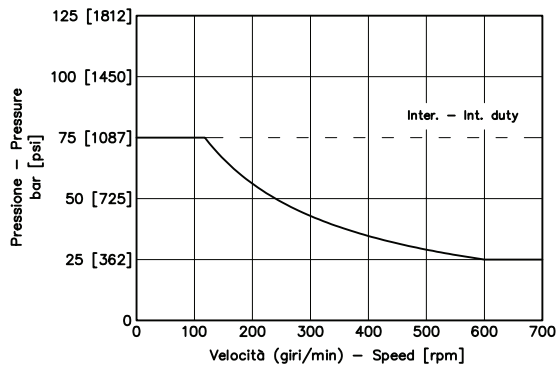

HPS

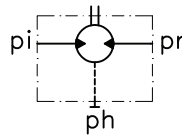
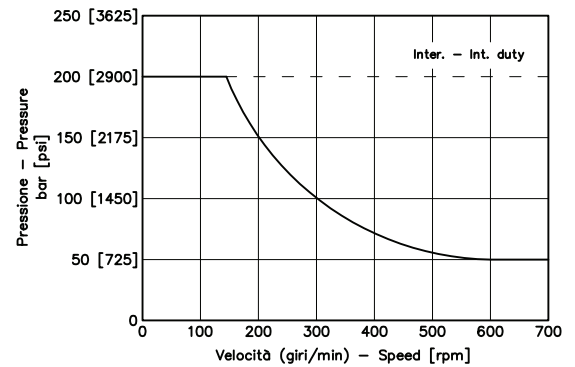

$$Ph = \frac{pi + pr}{2} [bar]$$

ph = pressione in carcassa
pi = pressione di alimentazione
pr = pressione di scarico

ph = housing pressure
pi = inlet pressure
pr = outlet pressure

- La pressione in carcassa senza drenaggio è data dalla media tra pi e pr.
- Il motore BH è fornito con drenaggio (STANDARD)
- La massima pressione di scarico con drenaggio è di 138 bar Cont.
- The case pressure without drain line is the average between inlet and return pressure.
- As standard, BH motors are supplied with drain port.
- Max. permissible return (back) pressure with drain line 138 bar [2000 psi] Cont.

Le seguenti lettere o numeri del codice, sono state sviluppate per identificare tutte le configurazioni possibili dei motori BH. Usare il seguente modulo per identificare le caratteristiche desiderate. **Tutte le lettere o numeri del codice devono comparire in fase d'ordine.** Si consiglia di leggere attentamente il catalogo prima di iniziare la compilazione del codice di ordinazione.

The following alphanumeric digits system has been developed to identify all of the configuration options for the BH motors. Use the model code below to specify the desired features. **All alphanumeric digits system of the code must be present when ordering.** We recommend to carefully read the catalogue before filling the ordering code.

CODICE PRODOTTO / MODEL CODE

1	2	3	4	5	6	7	8	8A	9	10

1 - SERIE / SERIES

BH	Motore orbitale Orbital motor
----	----------------------------------

2 - VERSIONI / VERSIONS

S	Versione S S Version	
P	Versione P P Version	Speciale a richiesta Special on request

3 - CILINDRATA / DISPLACEMENT

050	47.8 cm ³ /giro [2.91 in ³ /rev]
080	73 cm ³ /giro [4.45 in ³ /rev]
100	101 cm ³ /giro [6.16 in ³ /rev]
130	126.5 cm ³ /giro [7.71 in ³ /rev]
160	165.3 cm ³ /giro [10.08 in ³ /rev]
200	192.4 cm ³ /giro [11.73 in ³ /rev]
250	239.1 cm ³ /giro [14.58 in ³ /rev]
315	286.9 cm ³ /giro [17.50 in ³ /rev]
400	382.5 cm ³ /giro [23.33 in ³ /rev]

4 - FLANGIA / MOUNTING FLANGE

			VERSIONI / VERSIONS	
			S	P
6A	Ovale 6 Fori Oval 6 Bolts	STANDARD	•	/
S4	4 fori 3/8 16 UNC - Ø44,45mm 4 Bolt 3/8 16 UNC - Ø1.75 in		•	•
4M	4 fori M10 - Ø44,45mm 4 Bolt M10 - Ø1.75 in		•	/

• Disponibile - Available / Non Disponibile - Not Available

1	2	3	4	5	6	7	8	8A	9	10

5 - ATTACCHI / MAIN PORTS

			VERSIONI / VERSIONS	
			S	P
S08	Attacchi 7/8" - 14 UNF SAE10 (no flangia 4M) 7/8" - 14 UNF SAE10 Main Ports (not 4M flange)	STANDARD	•	/
SS8	Attacchi 1/2" - 14 NPTF (no flangia 4M) 1/2" - 14 NPTF Main Ports (not 4M flange)		•	/
MS8	Attacchi G 1/2 BSPP (no flangia 4M) G 1/2 BSPP Main Ports (not 4M flange)		•	/
BFL	Attacchi Manifold (no flangia 4M) Manifold Main Ports (not 4M flange)		•	/
BFM	Attacchi Manifold (ISO) (Solo con flangia 4M) Manifold Main Ports (ISO) (Only with 4M flange)		•	/
F08	Attacchi Frontali 1/2 G BSPP (no flangia 4M) 1/2 G BSPP (End Main Ports) (not 4M flange)		/	•
FS8	Attacchi Frontali 3/4 - 16 UNF (no flangia 4M) 3/4 - 16 UNF (End Main Ports) (not 4M flange)		/	•

• Disponibile - Available / Non Disponibile - Not Available

6 - ESTREMITÀ ALBERO / OUTPUT SHAFT

			VERSIONI / VERSIONS	
			S	P
CL254	Albero Cilindrico Ø25.4 mm 1 in Parallel keyed	STANDARD	•	•
CL250	Albero Cilindrico Ø25 mm 0.97 in Parallel keyed		•	•
LC250	Albero Cilindrico Ø25 mm (Chiavetta 7x7x31.5mm) 0.97 in Parallel keyed (7x7x31.5mm [0.275x0.275x1.24in] key)		•	/
CS254	Albero Cilindrico Ø25.4 mm foro spina 1 in Parallel crosshole		•	/
SE250	Albero Scanalato (profilo SAE 6B 1" Z6) Splined Shaft (SAE 6B 1" 6T spline)		•	•
SE210	Albero Scanalato (profilo ANSI-B92.1a-1976-16/32 Z13) Splined Shaft (ANSI-B92.1a-1976-16/32 13T spline)	Speciale a richiesta Special on request	•	•

• Disponibile - Available / Non Disponibile - Not Available

7 - TENUTE / SEALS

N	NBR
---	-----

8 - VALVOLE / VALVES

XXXX	Non Richieste Not Required
------	-------------------------------

8A - CARATTERISTICA VALVOLA / VALVES FEATURE

000	Caratteristica non necessaria Feature not necessary
-----	--

1	2	3	4	5	6	7	8	8A	9	10

9 - CARATTERISTICA VERSIONE / VERSION FEATURE

			VERSIONI / VERSIONS	
			S	P
XXX	Guarnizione alta pressione (senza Drenaggio posteriore) High Pressure Seal (without Rear drain)		•	/
QDR	Versione QUAD-RING con Drenaggio posteriore 1/4 G (BSPP) QUAD-RING Version with Rear drain 1/4 G (BSPP)	STANDARD	•	/
QDS	Versione QUAD-RING con Drenaggio posteriore 7/16" 20UNF2B QUAD-RING Version with Rear drain 7/16" 20UNF2B		•	/
DPS	Guarnizione alta pressione con Drenaggio posteriore 7/16" 20UNF2B High Pressure Seal with Rear drain 7/16" 20UNF2B		•	•
DPM	Guarnizione alta pressione con Drenaggio posteriore 1/4 G (BSPP) High Pressure Seal with Rear drain 1/4 G (BSPP)		•	•

• Disponibile - Available / Non Disponibile - Not Available

10 - OPZIONI / OPTIONS

XX	Non verniciato Not Painted
01	Verniciato Nero RAL 9005 Black Painted RAL 9005

Flangia S4 Flange

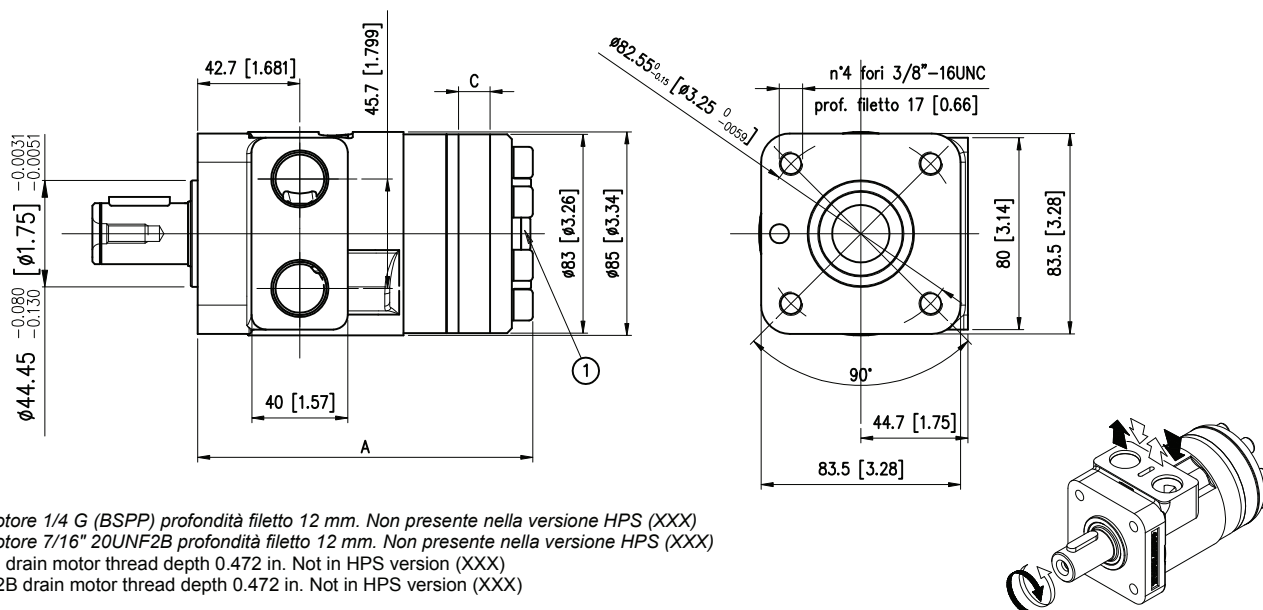

- 1) Drenaggio motore 1/4 G (BSPP) profondità filetto 12 mm. Non presente nella versione HPS (XXX)
Drenaggio motore 7/16" 20UNF2B profondità filetto 12 mm. Non presente nella versione HPS (XXX)
1/4 G (BSPP) drain motor thread depth 0.472 in. Not in HPS version (XXX)
7/16" 20UNF2B drain motor thread depth 0.472 in. Not in HPS version (XXX)

		BH 050	BH 080	BH 100	BH 130	BH 160	BH 200	BH 250	BH 315	BH 400
A	mm [in]	133.1 [5.24]	136.3 [5.36]	140 [5.51]	143.7 [5.65]	148.7 [5.85]	152.2 [5.99]	158.5 [6.24]	164.9 [6.49]	177.6 [6.99]
C	mm [in]	6.3 [0.248]	9.5 [0.374]	13.2 [0.519]	16.9 [0.66]	21.9 [0.86]	25.4 [1.00]	31.7 [1.24]	38.1 [1.50]	50.8 [2.00]
Pesi - Weight	kg [lb]	5.5 [12.12]	5.6 [12.34]	5.8 [12.78]	5.9 [13]	6 [13.4]	6.3 [13.88]	6.5 [14.3]	6.8 [14.98]	7.2 [16]

Flangia 6A Flange

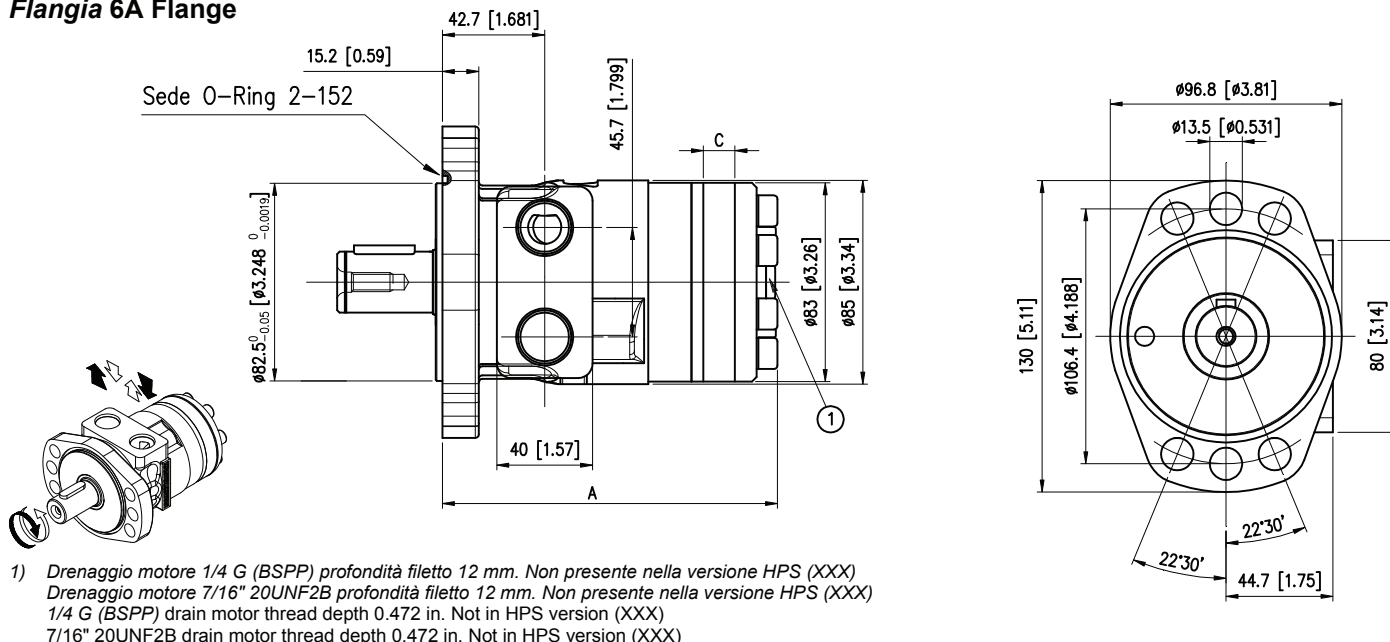

- 1) Drenaggio motore 1/4 G (BSPP) profondità filetto 12 mm. Non presente nella versione HPS (XXX)
Drenaggio motore 7/16" 20UNF2B profondità filetto 12 mm. Non presente nella versione HPS (XXX)
1/4 G (BSPP) drain motor thread depth 0.472 in. Not in HPS version (XXX)
7/16" 20UNF2B drain motor thread depth 0.472 in. Not in HPS version (XXX)

		BH 050	BH 080	BH 100	BH 130	BH 160	BH 200	BH 250	BH 315	BH 400
A	mm [in]	133.1 [5.24]	136.3 [5.36]	140 [5.51]	143.7 [5.65]	148.7 [5.85]	152.2 [5.99]	158.5 [6.24]	164.9 [6.49]	177.6 [6.99]
C	mm [in]	6.3 [0.248]	9.5 [0.374]	13.2 [0.519]	16.9 [0.66]	21.9 [0.86]	25.4 [1.00]	31.7 [1.24]	38.1 [1.50]	50.8 [2.00]
Pesi - Weight	kg [lb]	5.5 [12.12]	5.6 [12.34]	5.8 [12.78]	5.9 [13]	6 [13.4]	6.3 [13.88]	6.5 [14.3]	6.8 [14.98]	7.2 [16]

Flangia 4M Flange

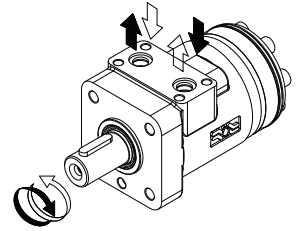
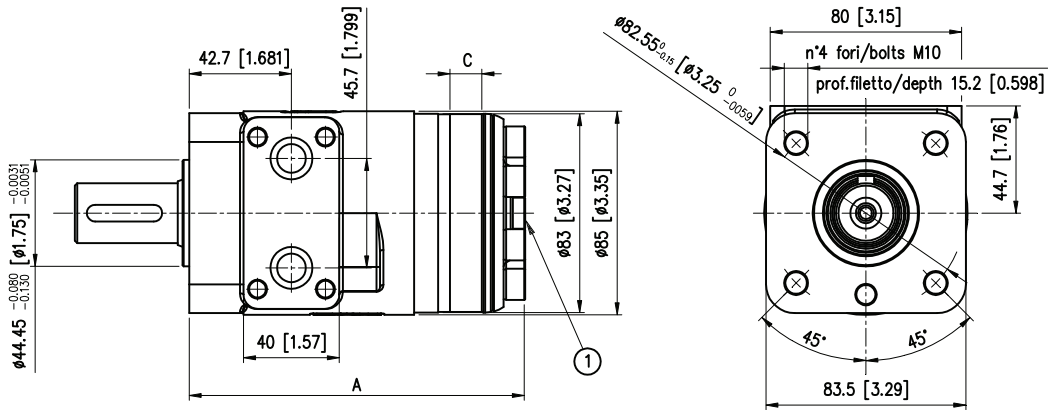

- 1) Drenaggio motore 1/4 G (BSPP) profondità filetto 12 mm. Non presente nella versione HPS (XXX)
 Drenaggio motore 7/16" 20UNF2B profondità filetto 12 mm. Non presente nella versione HPS (XXX)
 1/4 G (BSPP) drain motor thread depth 0.472 in. Not in HPS version (XXX)
 7/16" 20UNF2B drain motor thread depth 0.472 in. Not in HPS version (XXX)

		BH 050	BH 080	BH 100	BH 130	BH 160	BH 200	BH 250	BH 315	BH 400
A	mm [in]	133.45 [5.25]	136.65 [5.38]	140.4 [5.53]	143.9 [5.66]	149.05 [5.87]	152.65 [6]	158.85 [6.25]	165.2 [6.5]	177.9 [7]
C	mm [in]	6.3 [0.248]	9.5 [0.374]	13.2 [0.519]	16.9 [0.66]	21.9 [0.86]	25.4 [1.00]	31.7 [1.24]	38.1 [1.50]	50.8 [2.00]
Pesi - Weight	kg [lb]	5.5 [12.12]	5.6 [12.34]	5.8 [12.78]	5.9 [13]	6 [13.4]	6.3 [13.88]	6.5 [14.3]	6.8 [14.98]	7.2 [16]

ATTACCHI
OPTIONS

BH

MS8

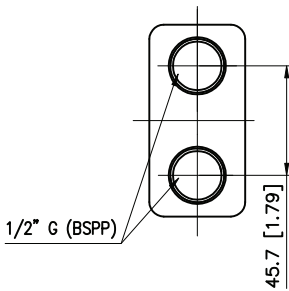

SS8

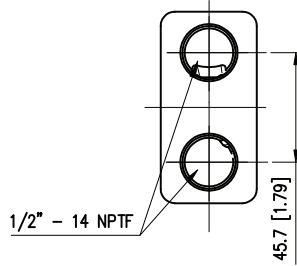

Manifold (BFL)

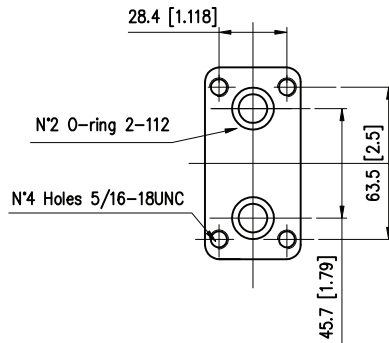

S08

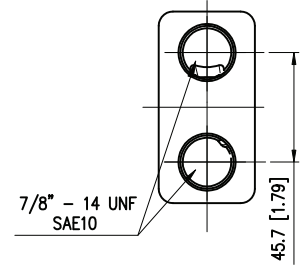

Manifold (BFM)

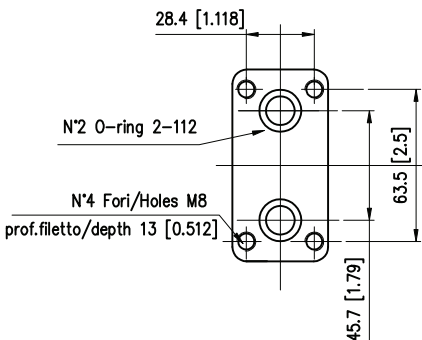

Flangia S4 Flange

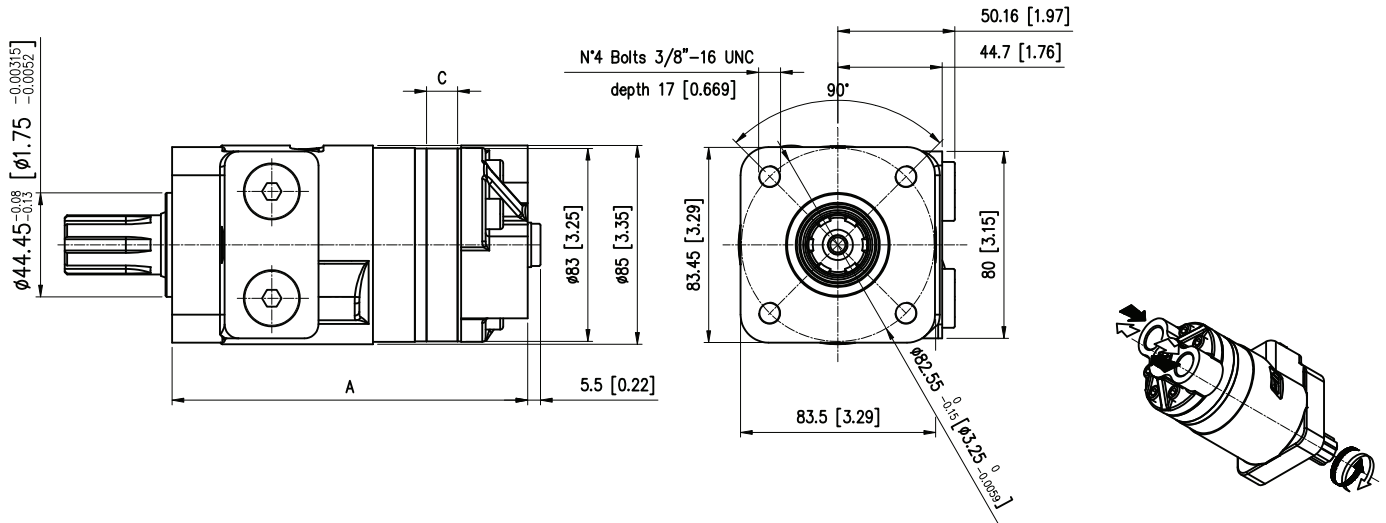

		BH 050	BH 080	BH 100	BH 130	BH 160	BH 200	BH 250	BH 315	BH 400
A	mm [in]	145.5 [5.72]	148.5 [5.84]	152 [5.98]	156 [6.14]	161 [6.33]	164.5 [6.47]	171 [6.73]	177 [6.96]	190 [7.48]
C	mm [in]	6.3 [0.248]	9.5 [0.374]	13.2 [0.519]	16.9 [0.66]	21.9 [0.86]	25.4 [1.00]	31.7 [1.24]	38.1 [1.50]	50.8 [2.00]
Pesi - Weight	kg [lb]	5.8 [12.78]	5.9 [13]	6.1 [13.44]	6.2 [13.66]	6.4 [14.10]	6.6 [14.54]	6.8 [14.98]	7.1 [15.64]	7.6 [16.75]

OPZIONI ATTACCHI
OPTIONS MAIN PORTS

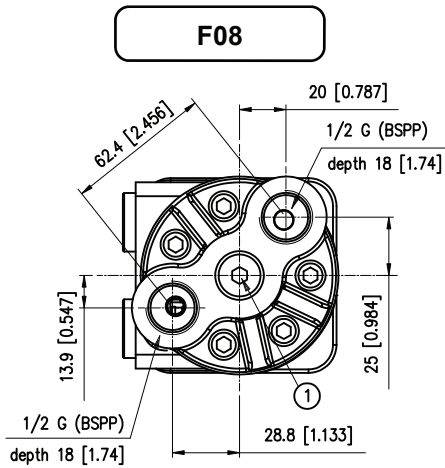

- 1) Drenaggio motore 1/4 G (BSPP) profondità filetto 12 mm.
1/4 G (BSPP) drain motor thread depth 12 mm [0.472 in].

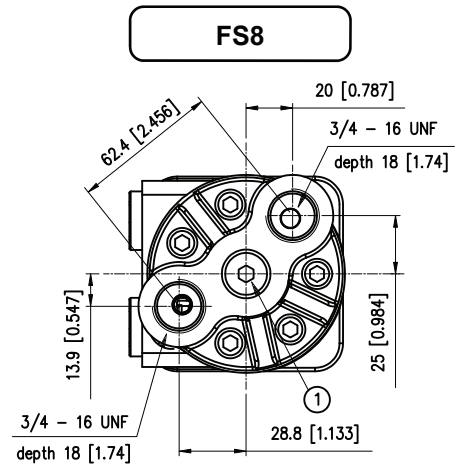

- 1) Drenaggio motore 7/16"-20 UNF profondità filetto 12 mm.
7/16"-20 UNF drain motor thread depth 12 mm [0.472 in].

Cilindrico CL254
Parallel CL254

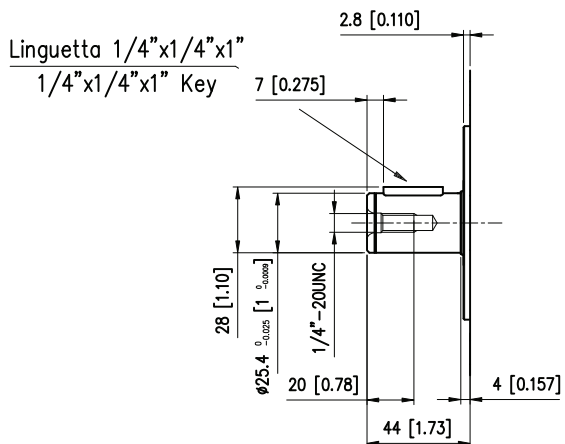

Coppia Massima 300 Nm
Max Torque Continuous 300 Nm [221.1 lbf-ft]

Scanalato SE250
Splined SE250

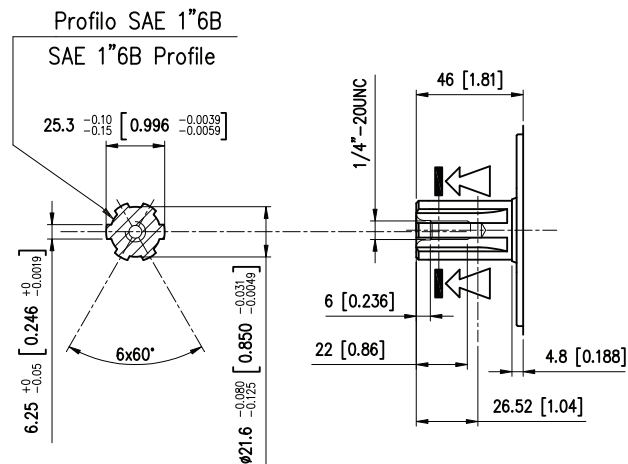

Coppia Massima 360 Nm
Max Torque Continuous 360 Nm [265.32 lbf-ft]

Scanalato SE210 (Speciale a richiesta)
Splined SE210 (Special on request)

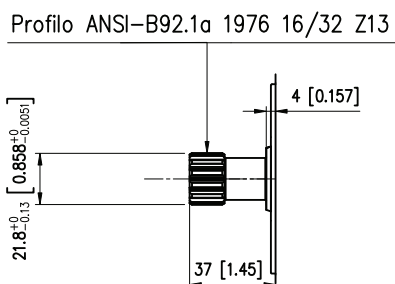

Coppia Massima 140 Nm
Max Torque Continuous 140 Nm [103.18 lbf-ft]

Cilindrico CS254
Parallel CS254

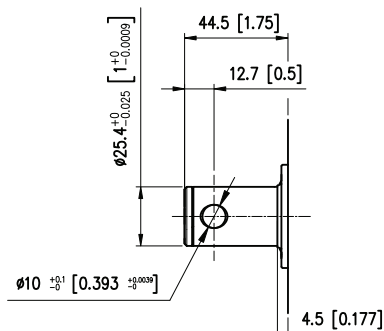

Coppia Massima 300 Nm
Max Torque Continuous 300 Nm [221.1 lbf-ft]

Cilindrico CL250
Parallel CL250

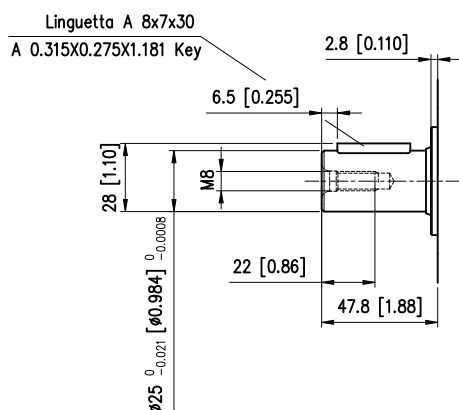

Coppia Massima 300 Nm
Max Torque Continuous 300 Nm [221.1 lbf-ft]

Cilindrico LC250
Parallel LC250

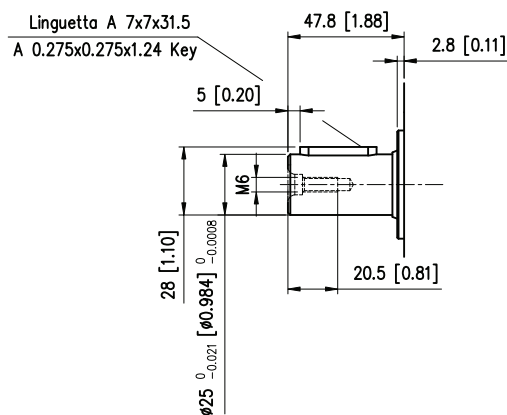

Coppia Massima 300 Nm
Max Torque Continuous 300 Nm [221.1 lbf-ft]

I carichi ammessi sull'albero variano in funzione di:

- Velocità (n)
- Distanza (L) dal punto di applicazione del carico alla flangia di montaggio
- Versione della flangia di montaggio

Formula utilizzabile per il calcolo del carico radiale (Pr) ai vari numeri di giri (n), e alle varie distanze (L) dalla flangia tipo "6A" ovale 6 fori.

Radial load capacity (Pr) curve according to speed (n) and distance (L) from flange, valid for the 6-bolt flange type "6A".

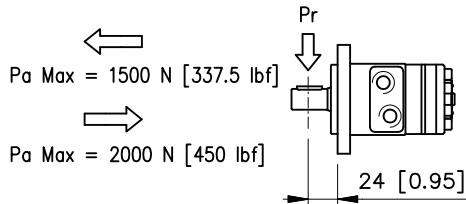

$$Pr = \frac{800}{n} \cdot \frac{242000}{97 + L} \text{ [N]}$$

Formula valida per n >= 200 rpm
Per n < 200 rpm Prmax = 8000 N

This formula being valid for n >= 200 rpm
For n < 200 rpm Prmax = 8000 N [1800 lbf]

The permissible radial shaft load depends on

- Speed (n)
- Distance (L) from the point of load to the mounting flange
- Mounting flange version

Formula utilizzabile per il calcolo del carico radiale (Pr) ai vari numeri di giri (n), e alle varie distanze (L) dalla flangia tipo "S4-4M" 4 fori.

Radial load capacity (Pr) curve according to speed (n) and distance (L) from flange, valid for the 4-bolt flange type "S4-4M".

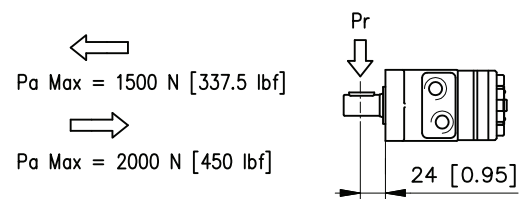

Formula valida per n >= 200 rpm
Per n < 200 rpm Prmax = 8000 N

This formula being valid for n >= 200 rpm
For n < 200 rpm Prmax = 8000 N [1800 lbf]

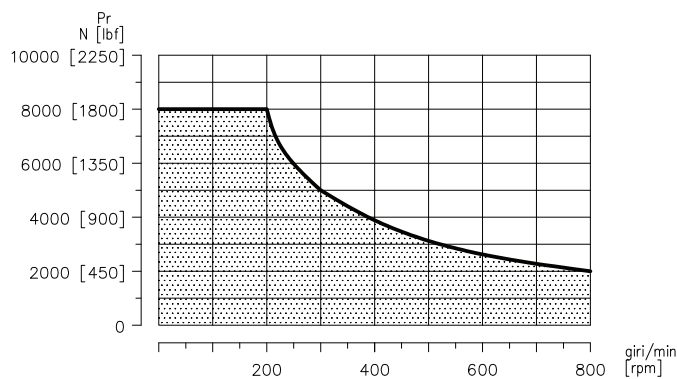

La curva mostra la relazione tra (Pr) e (n) quando:

- L = 24 mm [0.95 in] per motori flangia S4-4M e 6A

The curve shows the relation between (Pr) and (n)

- L = 24 mm [0.95 in] for motors with S4-4M and 6A flange

BG-BH 050

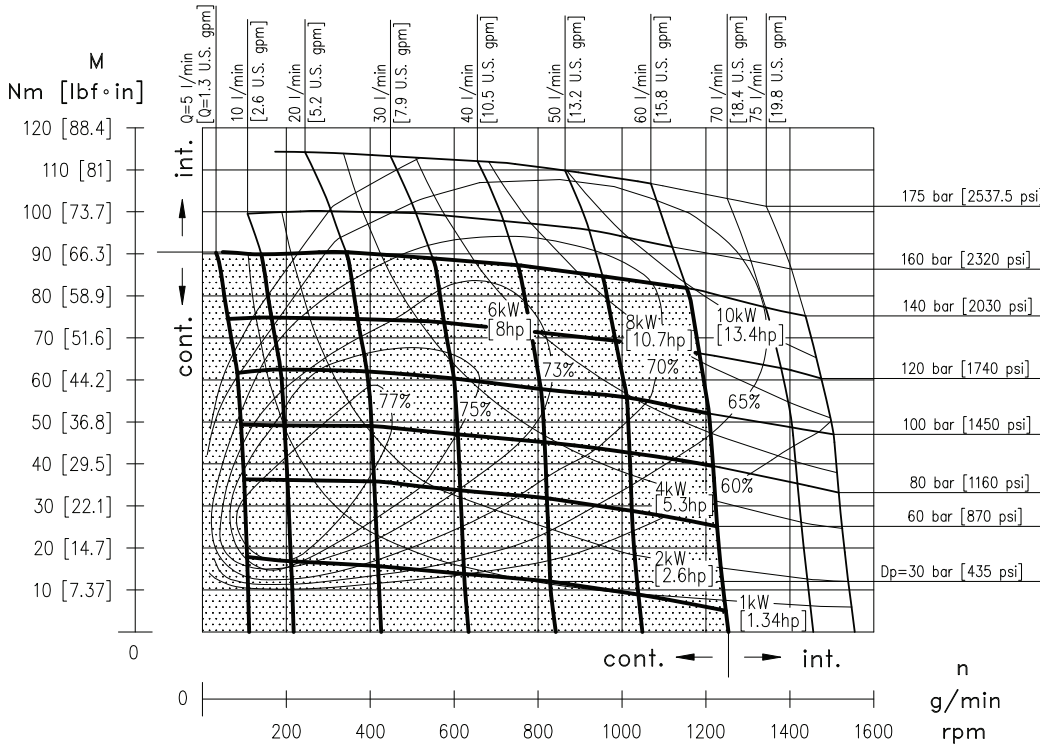

Pressioni e portate superiori a quelle ammesse in regime continuo non devono essere applicate contemporaneamente. Exceeding continuous pressure values or exceeding flow values indicated, must not occur simultaneously.

BG-BH 080

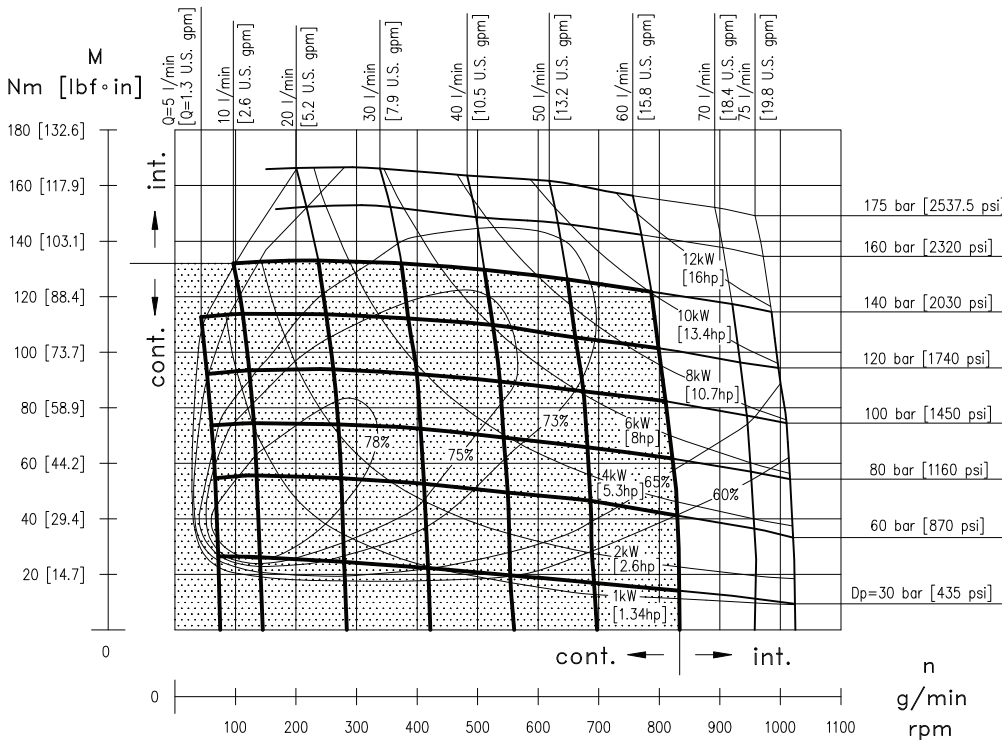

Pressioni e portate superiori a quelle ammesse in regime continuo non devono essere applicate contemporaneamente. Exceeding continuous pressure values or exceeding flow values indicated, must not occur simultaneously.

BG-BH 100

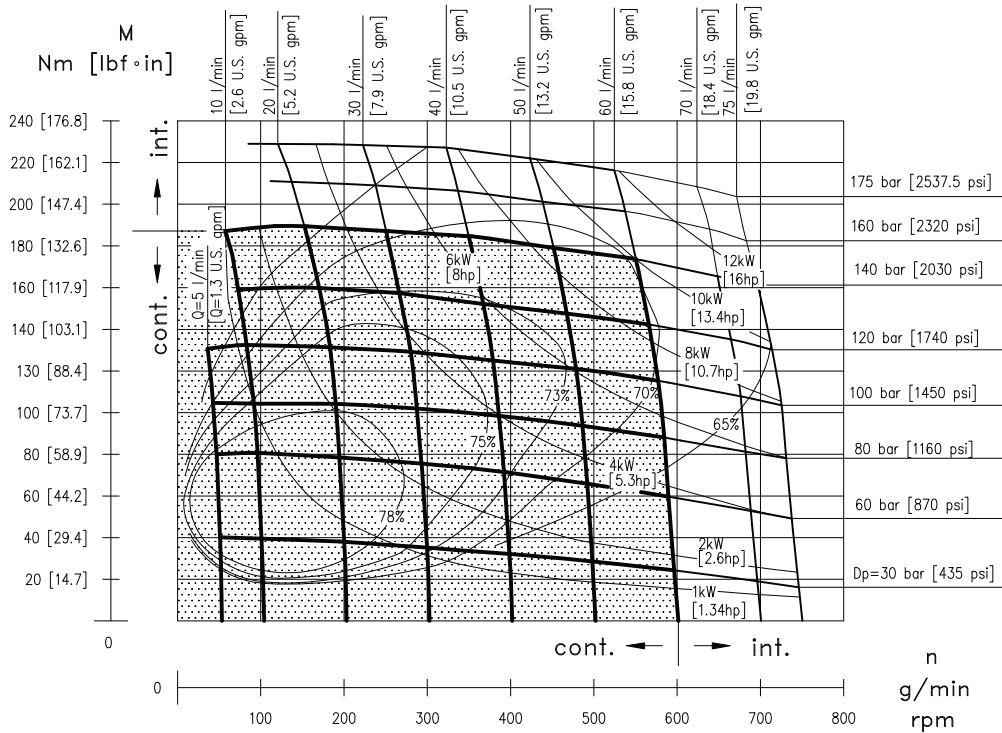

Pressioni e portate superiori a quelle ammesse in regime continuo non devono essere applicate contemporaneamente. Exceeding continuous pressure values or exceeding flow values indicated, must not occur simultaneously.

BG-BH 130

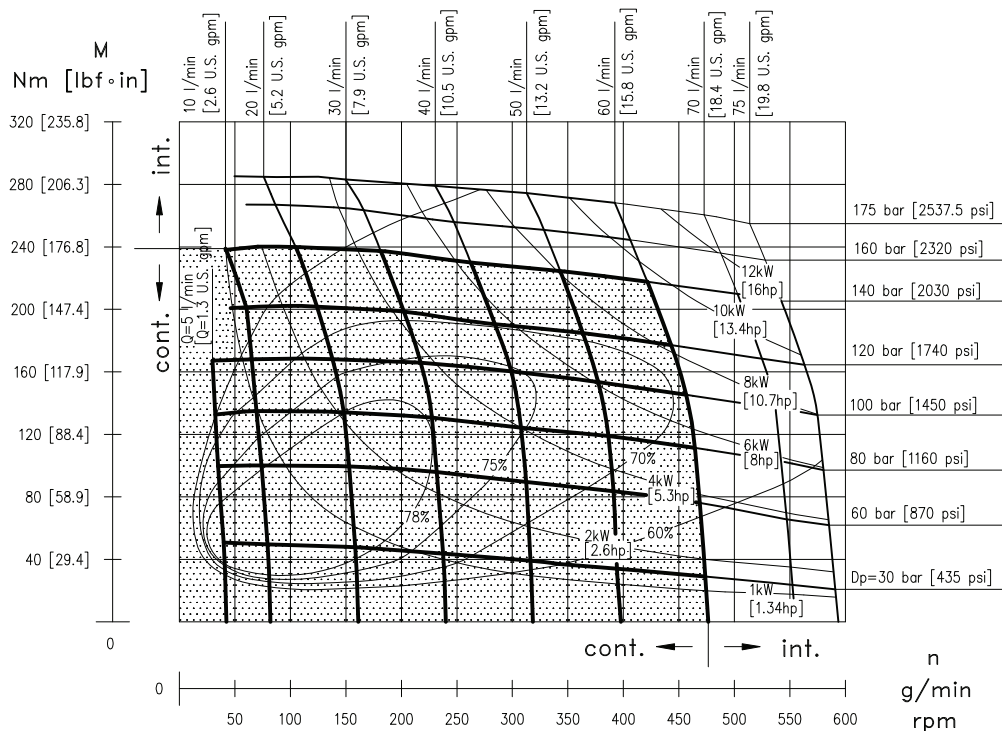

Pressioni e portate superiori a quelle ammesse in regime continuo non devono essere applicate contemporaneamente. Exceeding continuous pressure values or exceeding flow values indicated, must not occur simultaneously.

BG-BH 160

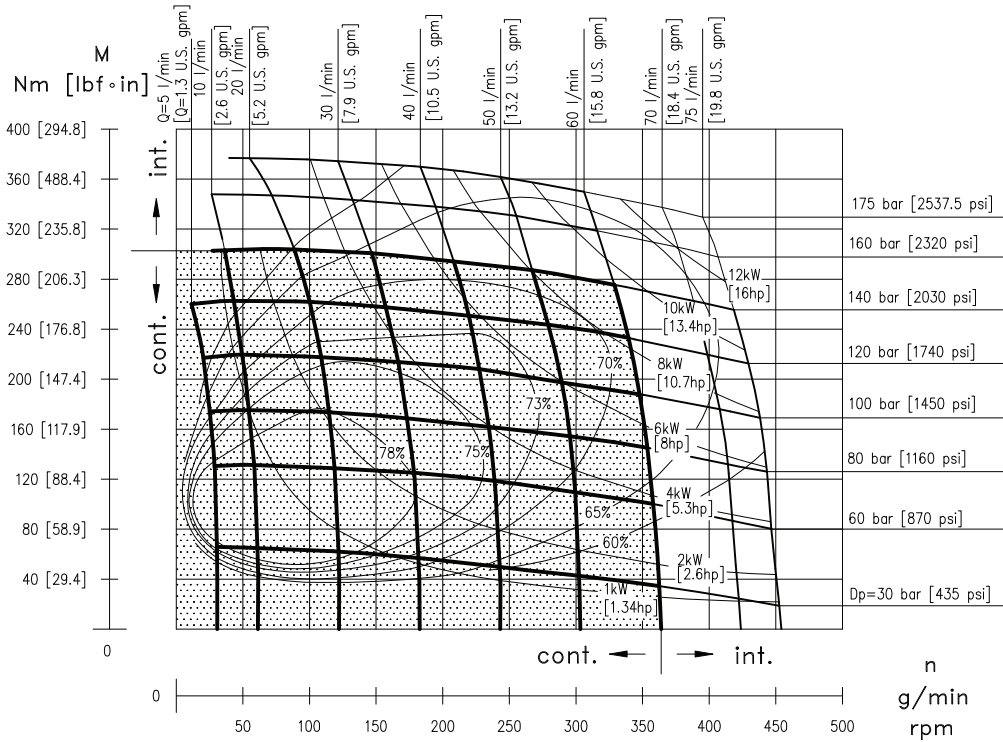

Pressioni e portate superiori a quelle ammesse in regime continuo non devono essere applicate contemporaneamente. Exceeding continuous pressure values or exceeding flow values indicated, must not occur simultaneously.

BG-BH 200

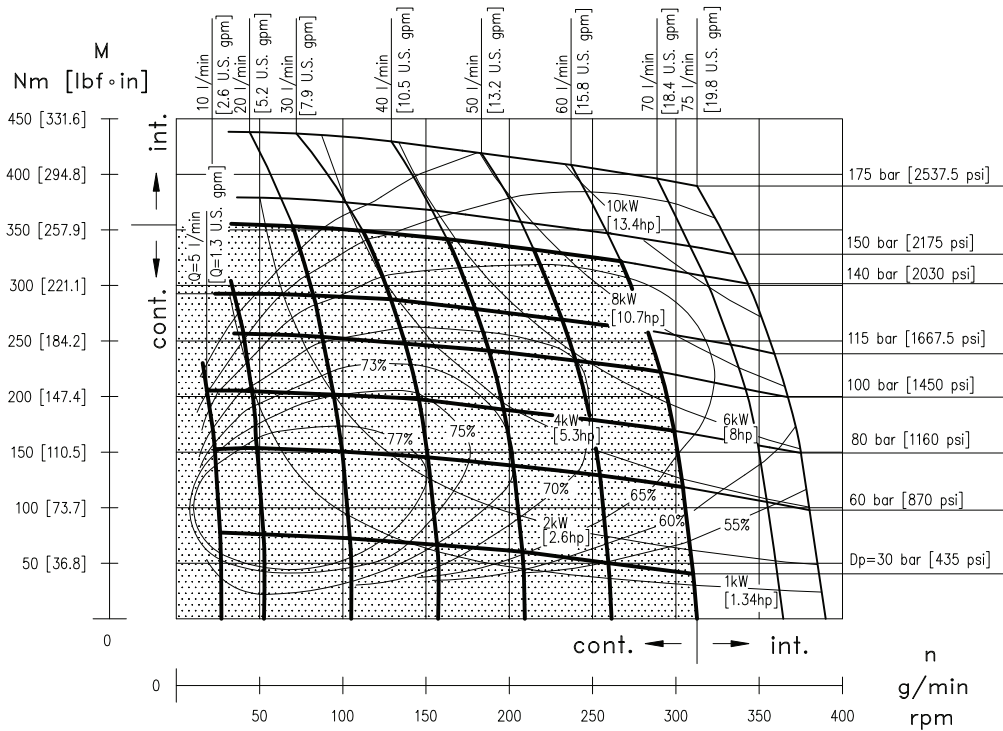

Pressioni e portate superiori a quelle ammesse in regime continuo non devono essere applicate contemporaneamente. Exceeding continuous pressure values or exceeding flow values indicated, must not occur simultaneously.

BG-BH 250

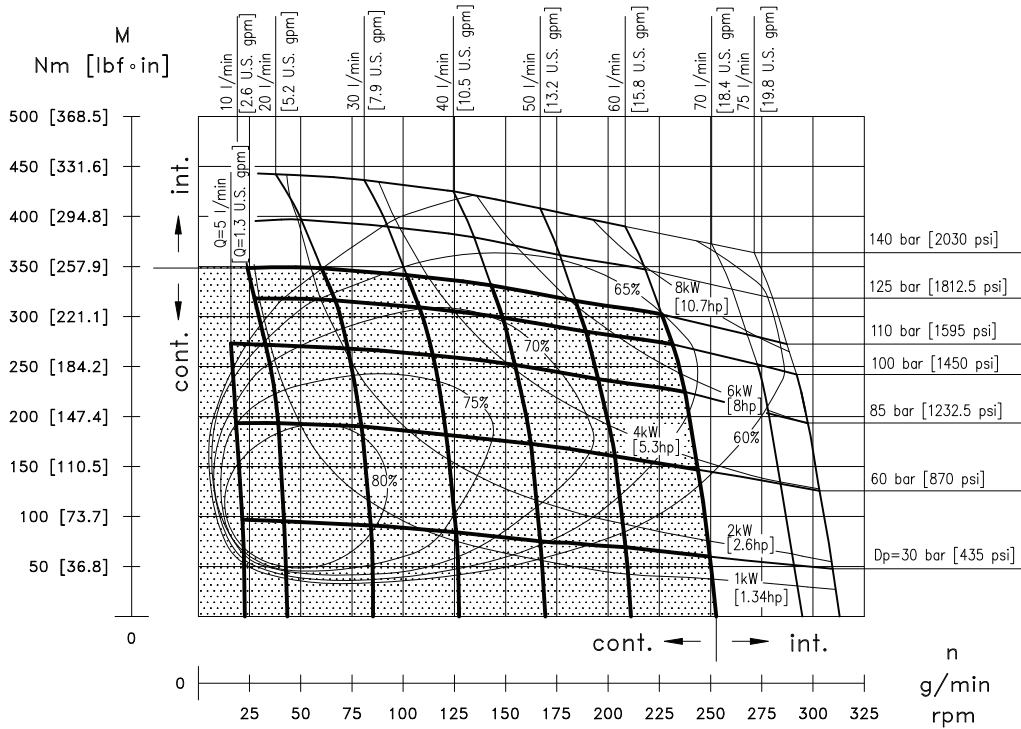

Pressioni e portate superiori a quelle ammesse in regime continuo non devono essere applicate contemporaneamente. Exceeding continuous pressure values or exceeding flow values indicated, must not occur simultaneously.

BG-BH 315

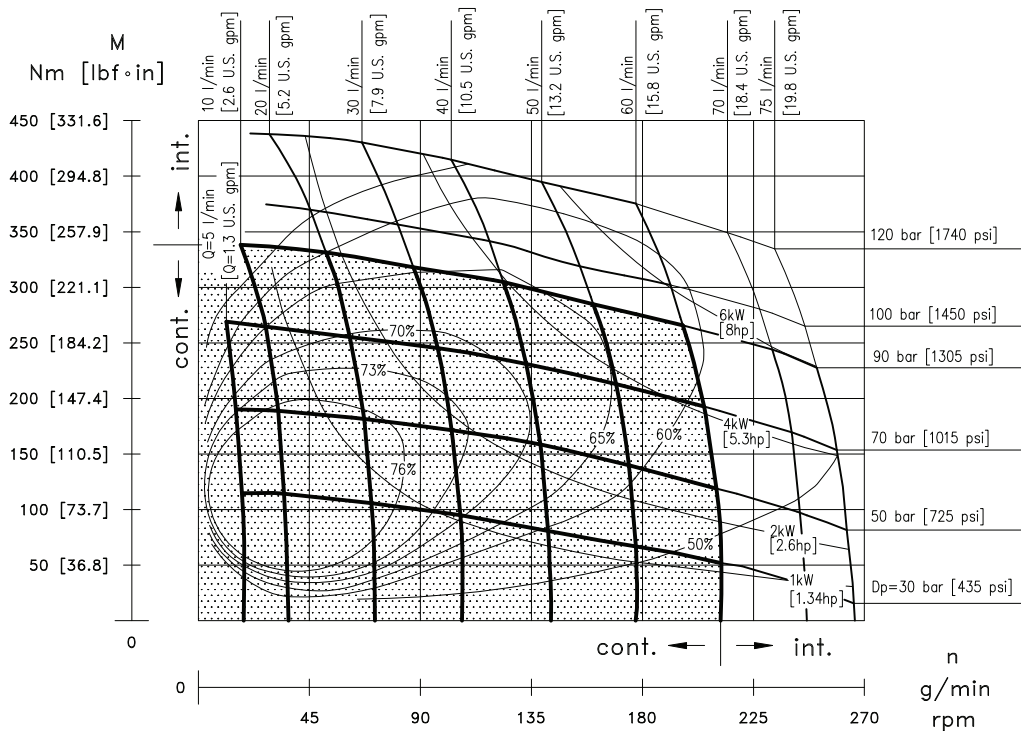

Pressioni e portate superiori a quelle ammesse in regime continuo non devono essere applicate contemporaneamente. Exceeding continuous pressure values or exceeding flow values indicated, must not occur simultaneously.

BG-BH 400

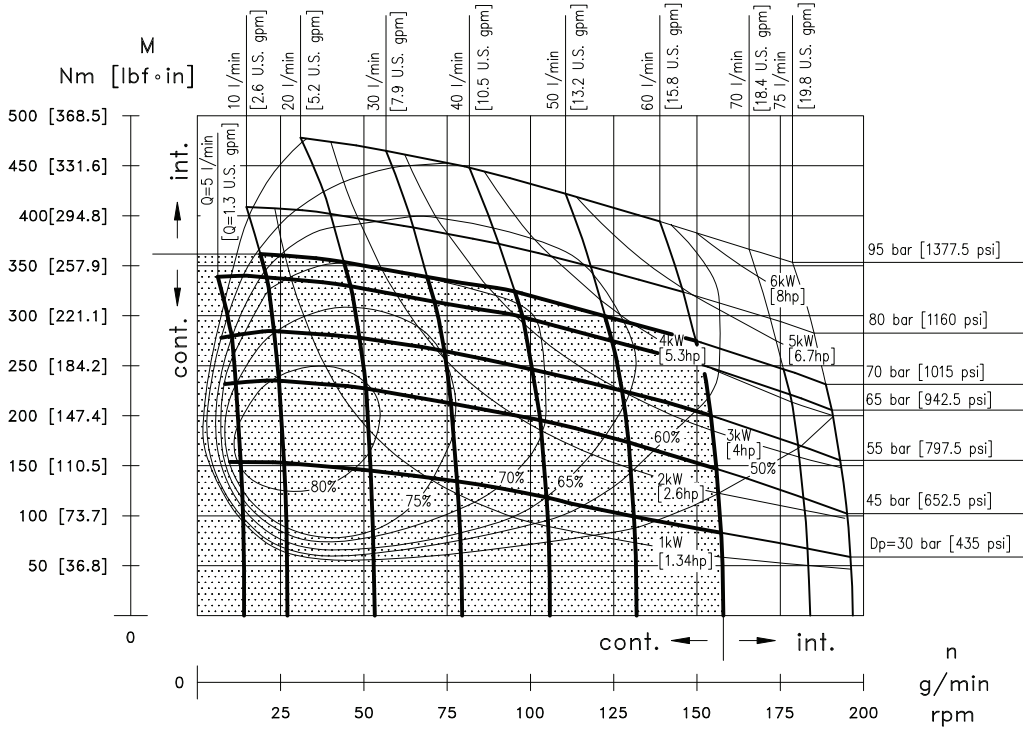

Pressioni e portate superiori a quelle ammesse in regime continuo non devono essere applicate contemporaneamente. Exceeding continuous pressure values or exceeding flow values indicated, must not occur simultaneously.

Nota: I diagrammi sono stati ottenuti con prove eseguite su un numero significativo di motori, utilizzando un olio avente una viscosità cinematica di 37 cSt alla temperatura di 45 C°.

Note: Diagrams according to tests done with a relevant number of motors and using hydraulic oil with kinematic viscosity of 37 cSt at 45 C° temperature.

Brevini Fluid Power S.p.A. Tutti i diritti riservati. Hydr-App, SAM Hydraulik, Aron, Brevini Hydraulics, BPE Electronics, VPS Brevini, OT Oiltechnology, sono marchi o marchi registrati di Brevini Fluid Power S.p.A. o da altre società del Gruppo Brevini in Italia ed in altri paesi.

Le caratteristiche tecniche fornite nel presente catalogo non sono impegnative e non sarà possibile basare alcun procedimento legale su tale materiale. Brevini Fluid Power non sarà responsabile per informazioni e specifiche che possano indurre ad errori o errate interpretazioni. Data la continua ricerca tecnologica volta a migliorare le caratteristiche tecniche dei nostri prodotti, Brevini Fluid Power si riserva il diritto di apportarvi senza alcun preavviso le modifiche che riterrà opportuno. E' vietata la riproduzione anche parziale senza la specifica autorizzazione scritta di Brevini Fluid Power. Questo catalogo sostituisce i precedenti.

L'utilizzo dei prodotti riportati su questo catalogo deve essere effettuato nel rispetto dei limiti di funzionamento riportati nelle specifiche tecniche, valutando il tipo di applicazione e le condizioni di funzionamento normali o in caso di avaria, in modo da non pregiudicare la sicurezza di persone e/o cose.

Condizioni generali di vendita: vedere sito www.brevinifluidpower.com.

I prodotti illustrati su questo catalogo fanno parte della linea  **SAMHYDRAULIK**

Brevini Fluid Power S.p.A. All rights reserved. Hydr-App, SAM Hydraulik, Aron, Brevini Hydraulics, BPE Electronics, VPS Brevini, OT Oiltechnology, logos are trademarks or are registered trademarks of Brevini Fluid Power S.p.A. or other companies of the Brevini Group in Italy and other countries.

The technical features supplied in this catalogue are non binding and no legal action can be taken against such material. Brevini Fluid Power will not be held responsible for information and specifications which may lead to error or incorrect interpretations. Given the continuous technical research aimed at improved technical features of our products, Brevini Fluid Power reserves the right to make change that are considered appropriate without any prior notice. This catalogue cannot be reproduced (in whole or in part) without the prior written consent of Brevini Fluid Power. This catalogue supersedes all previous ones.

Use of the products in this catalogue must comply with the operating limits given in the technical specifications. The type of application and operating conditions must be assessed as normal or in malfunction in order to avoid endangering the safety of people and/or items.

General terms and conditions of sale: see website www.brevinifluidpower.com.

The products shown on this catalog are parts of  **SAMHYDRAULIK** line.