

## Model RVT Pressure Relief

The Badestnost valve model RVT is a direct acting ball/spring type pressure relief. The valve is compact and simple in design. This type relief is fast opening and is well suited for pressure spike protection. The performance curves below indicate the low cracking pressure typical to ball/spring reliefs. Please refer to the model RVT for a system pressure relief. The valve is available with a standard steel seat, model RVT-S, or with a hardened seat, model RVT-H. Both models are externally adjustable.

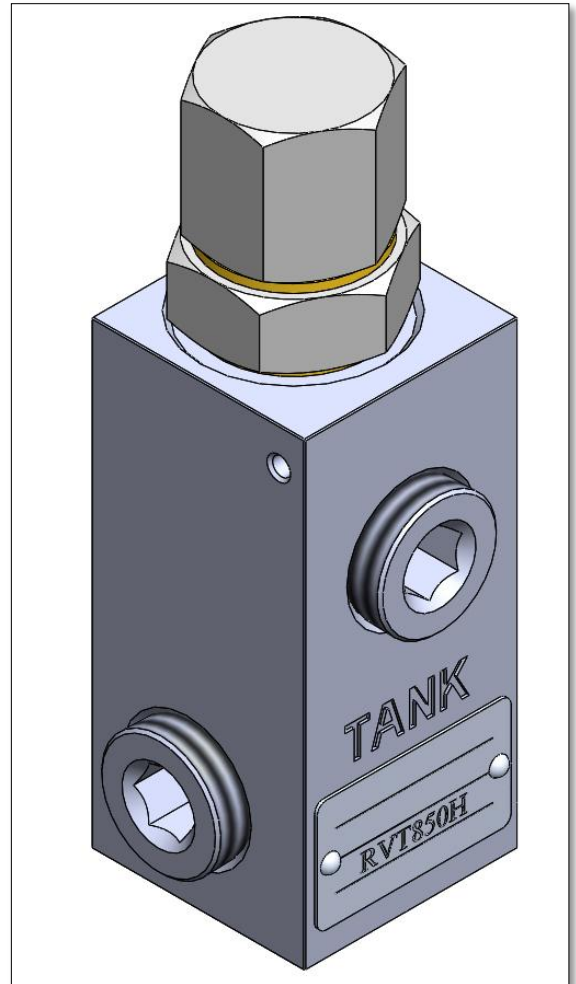

Standard Models Available		
Model #	Port Size	Max Flow [l/min (gpm)]
RVT-850S	1/2 NPTF	60(16)
RVT-850H	1/2 NPTF	60(16)
RVT-875S	3/4 NPTF	75(20)
RVT-875H	3/4 NPTF	75(20)

**NOTE:** For other port size, please contact the sales department.

**NOTE:**  
Relief settings are 100 bar at 45 l/min.  
For non-standard relief settings specify bar and l/min after model number.  
Ex. RVT-850H-80-40 for **80 bar at 40 l/min.**

**Hydraulic symbol:**

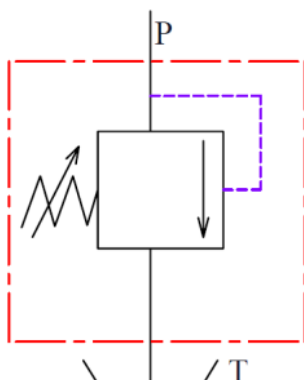

Valve specifications		
Capacity	l/min (gpm)	75 (20)
Max. pressure	bar (psi)	170 (2500)
Weight	kg (lbm)	0.9 (2)
Adjustment range	bar (psi)	70-170 (1000-2500)

## Model RVT Pressure Relief

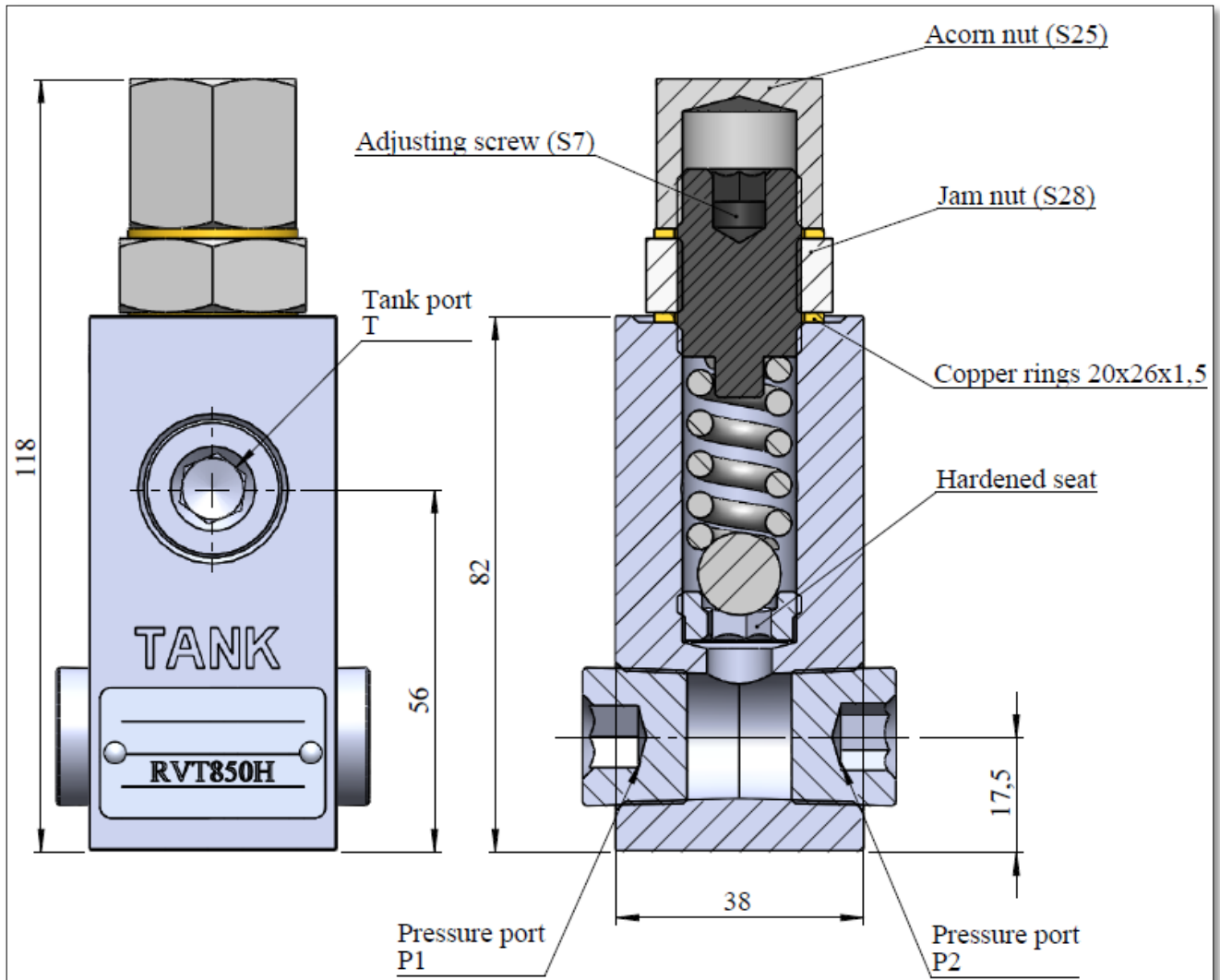

To adjust relief please remove acorn nut loosen jam nut, turn the adjusting screw clockwise to increase the pressure and counterclockwise to decrease the pressure.

**WARNING:** Overpressure may cause sudden and unexpected failure of a component in the hydraulic system resulting in serious personal injury. Always use a gauge when adjusting a relief valve.