

A-OWC-SE-...-L-FR

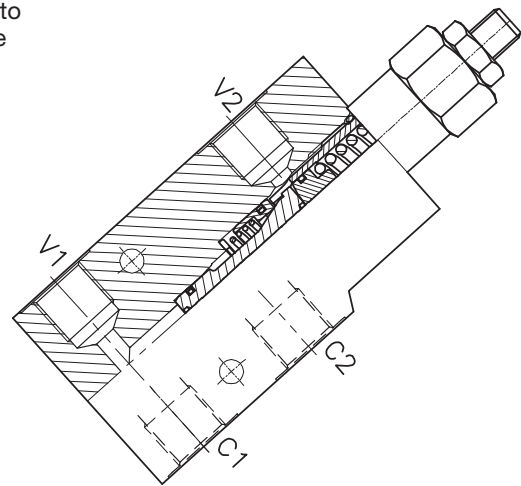
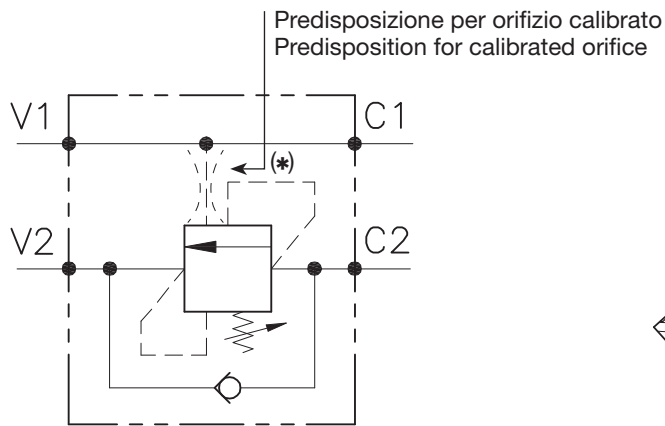

(*) Vedi codice ordinazione
See ordering code

CARATTERISTICHE

Luce nominale	DN 8/10
Portata min/max	1/60 l/min - 0.26/15.9 GPM
Pressione max. di picco	450 bar - 6525 PSI
Pressione max. di taratura	350 bar - 5075 PSI
Rapporto di pilotaggio standard	Vedi tab. / See tab.
Temperatura ambiente	-30°C + 50°C
Temperatura olio	-30°C + 80°C
Filtraggio consigliato	30 micron

PERFORMANCE

Rated size
Min/max flow-rate
Max peak pressure
Max setting pressure
Standard pilot ratio
Room temperature
Oil temperature
Recommended filtration

NOTE:

La taratura deve essere 1.3 volte maggiore della pressione indotta dal carico. Valve should be set at 1.3 times load induced pressure.

ESEMPIO/EXAMPLE:

Pressione di lavoro max

350 bar / 1.3 = 270 bar

Max working pressure

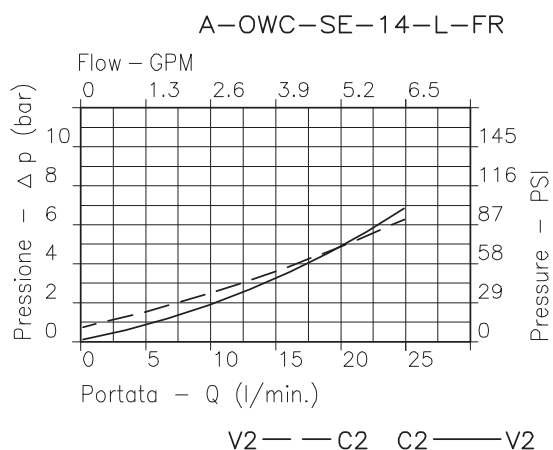
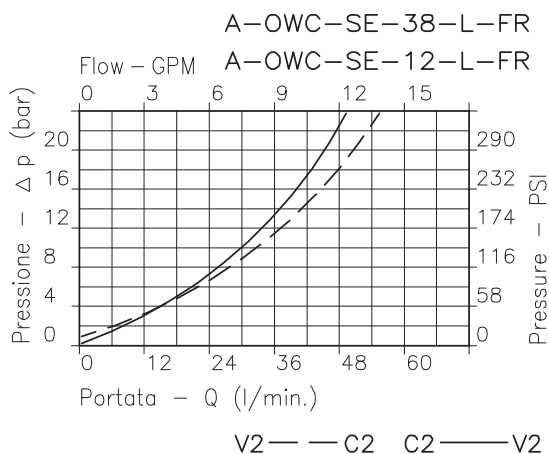

Viscosità olio 46 cSt a 50°C - Oil viscosity 46 cSt at 50°C

VALVOLA BILANCIAMENTO, BLOCCO E CONTROLLO MOVIMENTO A SEMPLICE EFFETTO CON COLLETTORE IN LINEA
SINGLE COUNTERBALANCE VALVE WITH IN LINE BODY

REGOLAZIONE
ADJUSTMENT →

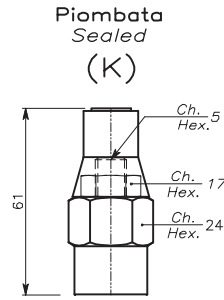
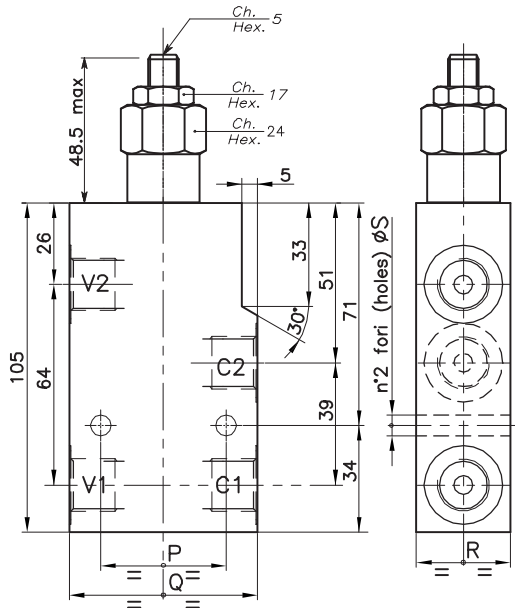

ESEMPIO TIPICO DI CIRCUITO
TYPICAL CIRCUIT EXAMPLE

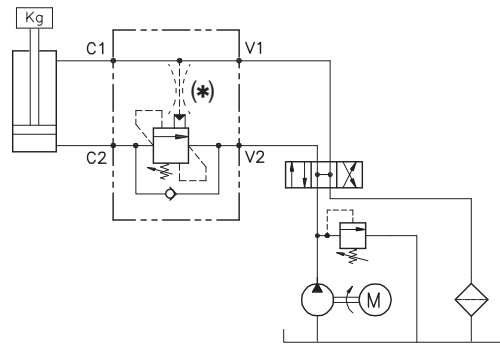

DIMENSIONI
DIMENSIONS

Campo taratura Setting range		P	Q	R	S	Attacchi Port size V2-C2 V1-C1 GAS (BSPP)	Luce nominale Rated size DN	Portata max Max flow-rate l/min - GPM
087	086	40	60	30	6.5	3/8"	8	40-10
093	088	50	70	35	8.5	1/2"	10	60-15

CODICE DI ORDINAZIONE
HOW TO ORDER

N01 . 087 . 0 X 0 . A 0A (*)

Campo taratura / Setting range			
087	086		
093	088		
Campo taratura 30÷220 bar (molla colore verde) Setting range 30÷220 bar (green spring)		Campo taratura 60÷350 bar (molla colore giallo) Setting range 60÷350 bar (yellow spring)	
Taratura standard (Q=5 l/1')	Incr. press. - bar giro/vite	Taratura standard (Q=5 l/1')	Incr. press. - bar giro/vite
Std. bar setting (Q=5 l/1')	Pressure rise - turn of screw	Std. bar setting (Q=5 l/1')	Pressure rise - turn of screw
180 bar	(50)	250 bar	(90)

Rapporto di pilotaggio Pilot ratios		Regolazione Adjustment		Collettore Body	
O	4.25: 1	X	Grano -Dowel	A	Acciaio zincato Zinc plated steel
D	8: 1	K	Piombata Sealed		

Smorzamento pilotaggio / Pilot damping	
sigla / title	Ø orifizio / orifice
0A	0,6 mm
0B	0,8 mm
0C	0,5 mm
0D	0,7 mm
ommettere / omit	senza / without