

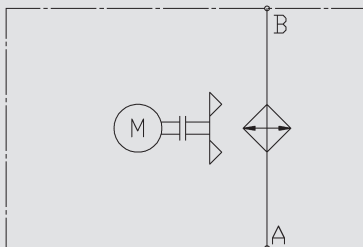

Air Cooler Industry

AC-LN / ACA-LN / ACAF-LN 8-14

Symbol



General

The AC-LN 8-14 air cooler series can be used in all areas where either oil or water-glycol is to be cooled with air. The coolers with an axial fan can be used in the return line as well as in the bypass flow.

The wide range of accessories and optional versions mean that the coolers can be adapted flexibly to various applications.

Product Features

The air flow of the cooler has been optimized by the use of a more efficient axial fan and a variety of housing modifications. As a result, the AC-LN series 8-14 is especially efficient and quiet.

The cooler can also be used in the bypass flow by attaching a boost pump. An additional filter enables continuous filtration of the medium; the cooler can then be connected as required.

- Large product range
- Large cooling performance range
- Modular design

Operation Data

Fluids	Oils (mineral oils, synthetic oils, high viscosity oils, biological oils, phosphate ester) Water-glycol (cooling fluid) HFC pressure fluids
Viscosity	AC-LN: 2.000 mm ² /s (standard) ACA-LN/ACAF-LN: see technical data
Temperature range	Minimum / maximum ambient temperature: -20 °C to +40 °C (standard) Maximum temperature of the medium: +130 °C Please contact the technical sales department in the event of deviating temperatures. Notice! Fan switching frequency at max. fan speed (max. volume of air) must be avoided when operating a cooler at which the temperature difference between the medium inlet at the cooler and the ambient temperature can be greater than 50°C. Quick changes in the temperature of the cooling element material can lead to a significant reduction in service life or to direct damage of the cooling element due to thermal shock. Please contact the technical sales department to receive information about controlled fan drives.
Pressure resistance of the cooling element	Dynamic operating pressure: 16 bar Static operating pressure: 21 bar
Fan	Axial fan in suction version (standard) Axial fan in blowing version on request (note: with blowing version approx. 10 % less cooling capacity)
Motor	Three-phase motor Efficiency class IE2 Protection class IP55 Insulation class F Other versions on request
ErP	The fan unit of the AC-LN corresponds to the minimum efficiency levels specified in the Ecodesign directive or ErP directive (Energy-related Products) 2009/125/EC.
Pump (only ACA-LN/ACAF-LN)	Screw pump with separate motor Pump motor speed: 3.000 rpm Negative suction pressure of the pump: max. -0.4 bar
Noise levels	See technical data AC-LN and ACA-LN/ACAF-LN The noise levels are only reference values as the acoustic properties of a room, connections and reflection have an effect on the noise level.
Accessories	Integrated pressure bypass valve (IBP) or integrated thermal pressure bypass valve (IBT) (cannot be retrofitted, also see options) Thermostats Air filter grid or air filter mat Vibration damper

Application Field

Systems with high cooling requirements, such as:

- Hydraulic systems
- Lubrication systems
- Gears
- Motors
- Generators
- Converters
- Machine tools

Options

Integrated pressure bypass valve (IBP) / Integrated thermal pressure bypass valve (IBT)

The bypass channel is integrated in the cooling element. If a particular pressure is exceeded, the IBP opens the bypass channel, thereby protecting the cooling element from too high a pressure. Furthermore, the IBT only opens the cooling element path once a particular temperature has been reached.

Large coolers

Coolers with a higher cooling capacity than standard are also available as special versions.

Speed control: AC-LN MI

The integrated frequency converter enables stepless speed control dependent on the oil temperature in the cooling element.

ATEX

The AC-LN (without pump and filter) is also available for operation in gas and dust explosive areas. The ATEX certification applies for a frequency of 50 Hz and 60 Hz.

Marine

The MAR version is for aggressive ambient conditions, such as industrial atmospheres, high humidity or high salt content, which place great demands on the corrosion resistance and robustness of the materials used.

Cold Climate / Hot Climate

Use in extreme ambient conditions:
Cold Climate to -40 °C,
Hot Climate to +60 °C

The various versions can also be combined. Our technical sales department will be happy to assist you further.

Design

AC-LN 8-9-10-11

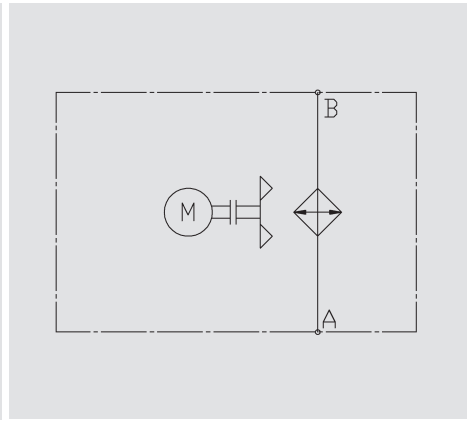
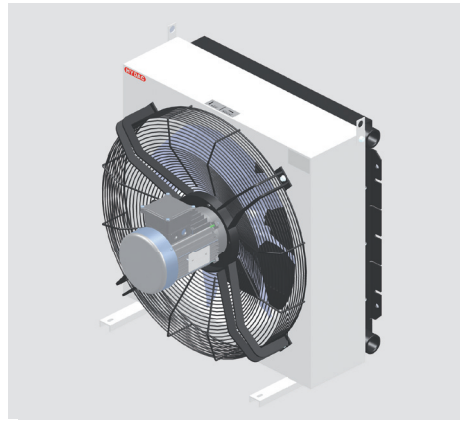

- 1 Motor
- 2 Axial fan
- 3 Fan housing
- 4 Heat exchanger

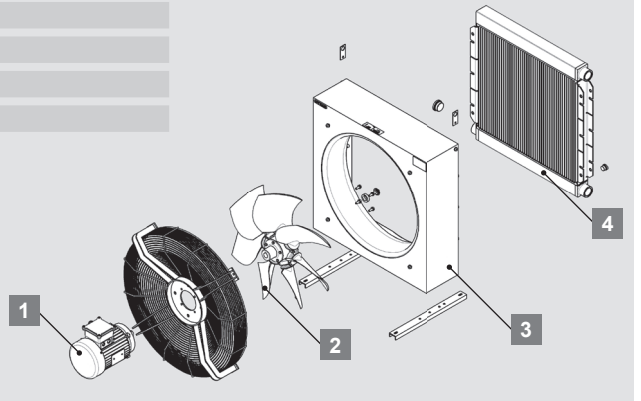

AC-LN 12-14

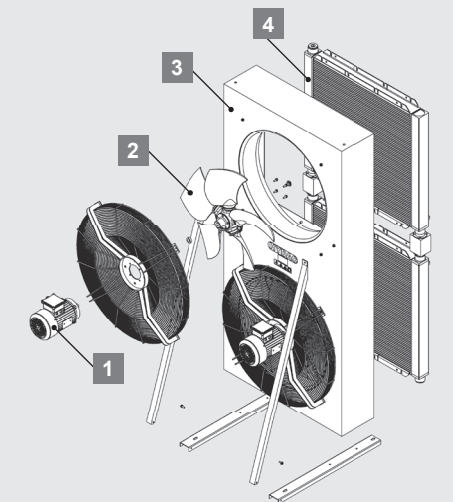
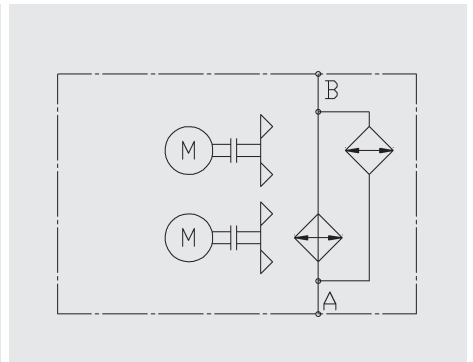
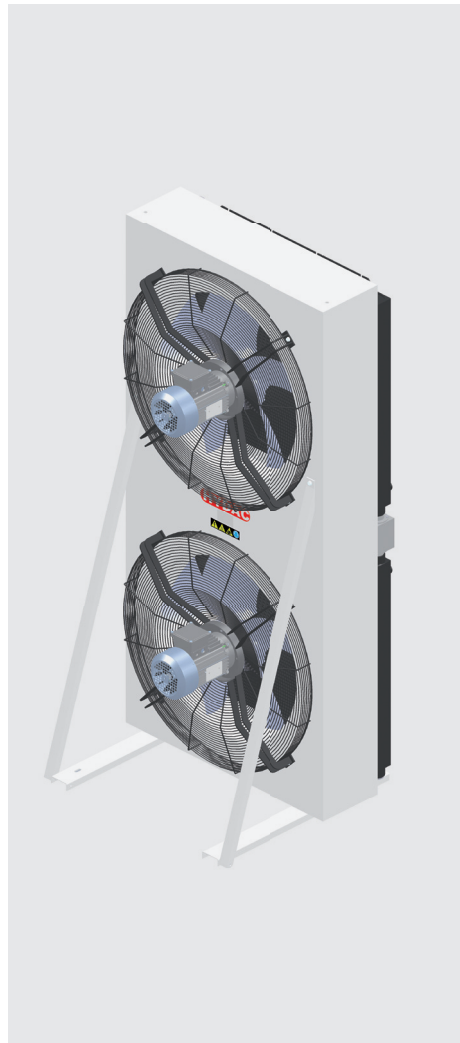

- 1 Motor
- 2 Axial fan
- 3 Fan housing
- 4 Heat exchanger

Design

ACA-LN8-9-10-11

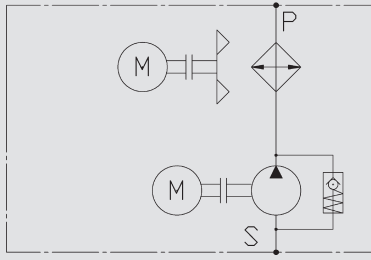
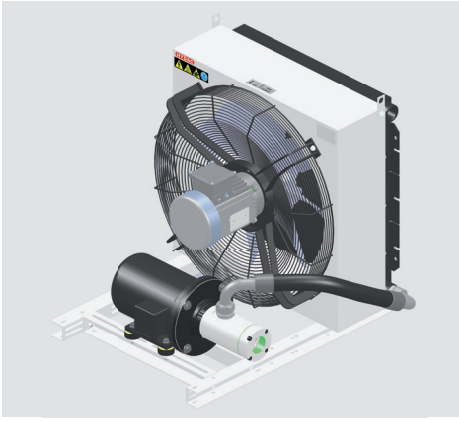

- 1 Drive motor
- 2 Axial fan
- 3 Low-noise screw pump
- 4 Fan housing
- 5 Heat exchanger

With external motor-pump assembly attached onto the base frame.

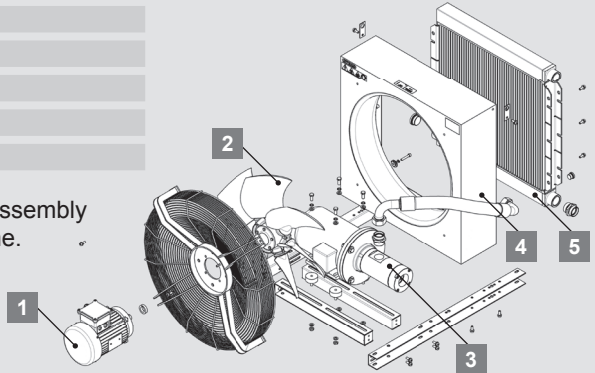

ACAF-LN8-9-10-11

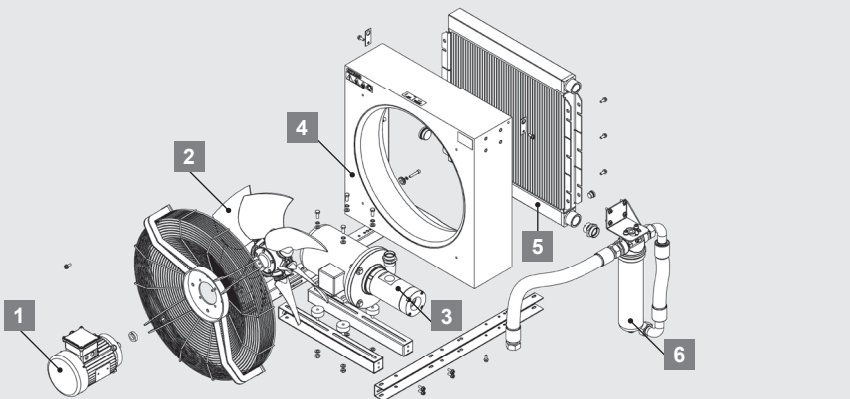
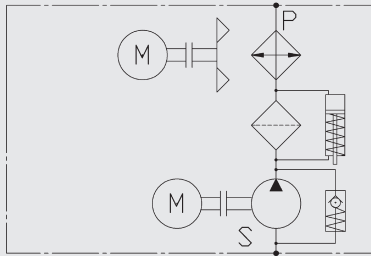
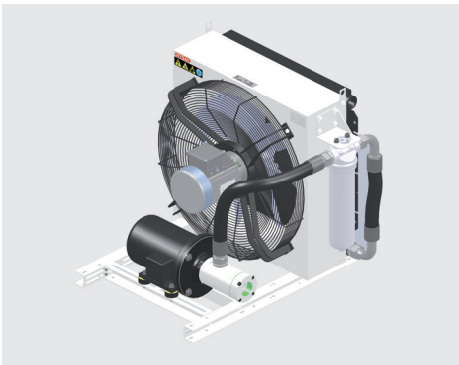

- 1 Drive motor
- 2 Axial fan
- 3 Low-noise screw pump
- 4 Fan housing
- 5 Heat exchanger
- 6 Filter

With external motor-pump assembly attached onto the base frame.

The filter is equipped with a visual clogging indicator as standard.

Technical Data

AC-LN

Type of cooler	P/N	Fluid [-] ¹⁾	Fluid flow [l/min] ²⁾	Air flow [m ³ /h]	Fan motor: Poles / size / flange	Fan motor: Power / current absorption [kW / A] ³⁾	Noise level (at 1 m distance, 50 Hz) [dB(A)]	Volume [l] ⁴⁾	Weight [kg] ⁵⁾
----------------	-----	-------------------------	----------------------------------	------------------------------	-------------------------------------	---	---	--------------------------	---------------------------

VERSION B: 50 Hz

AC-LN8L	3686293	F	350	5,800	6/90/B14	0.75 / 2.0	68	6	72
AC-LN8S	3686305	F	350	8,700	4/90/B14	1.5 / 3.3	79	6	72
AC-LN9L	3686306	F	350	7,500	6/90/B14	0.75 / 2.0	67	11	100
AC-LN9S	3770160	F	350	10,900	4/90/B14	1.5 / 3.3	80	11	100
AC-LN10L	3686307	F	540	11,300	6/90/B14	1.1 / 2.65	71	14	129
AC-LN10S	3773324	F	540	16,500	4/100/B14	3.0 / 6.0	77	14	129
AC-LN11L	3686308	F	540	17,400	6/112/B14	2.2 / 4.6	75	18	170
AC-LN11S	3773334	F	540	23,600	4/112/B14	4.0 / 7.7	81	18	170
AC-LN12L	3704261	F	840	22,600	6/90/B14	1.1 / 2.65	74	28	290
AC-LN12S	3773864	F	840	33,000	4/100/B14	3.0 / 6.0	80	28	290
AC-LN14L	3704260	F	840	34,800	6/112/B14	2.2 / 4.6	78	35	320
AC-LN14S	3773890	F	840	47,200	4/112/B14	4.0 / 7.7	84	35	320

VERSION C: 60 Hz

AC-LN8L	3763003	F	350	6,150	6/90/B14	0.9 / 2.0	71	6	72
AC-LN8S	3763036	F	350	8,700	4/90/B14	1.8 / 3.3	83	6	72
AC-LN9L	3763004	F	350	7,500	6/90/B14	0.9 / 2.0	70	11	100
AC-LN9S	3772994	F	350	10,900	4/90/B14	1.8 / 3.3	83	11	100
AC-LN10L	3733086	F	540	12,000	6/90/B14	1.3 / 2.7	74	14	129
AC-LN10S	3774291	F	540	16,400	4/100/B14	3.6 / 7.2	80	14	129
AC-LN11L	3763035	F	540	18,300	6/112/B14	2.6 / 4.6	78	18	170
AC-LN11S	3774293	F	540	23,600	4/112/B14	4.8 / 8.0	84	18	170
AC-LN12L	3765763	F	840	24,000	6/90/B14	1.3 / 2.7	77	28	290
AC-LN12S	3774304	F	840	32,800	4/100/B14	3.6 / 7.2	83	28	290
AC-LN14L	3765740	F	840	36,600	6/112/B14	2.6 / 4.6	81	35	320
AC-LN14S	3774312	F	840	47,200	4/112/B14	4.8 / 8.0	87	35	320

¹⁾ Medium: F = mineral oil or water-glycol, M = mineral oil

²⁾ Max. flow rate

³⁾ Current requirement: B version at 400 V – 50 Hz / C version at 480 V – 60 Hz, AC-LN 12-14: each motor

⁴⁾ Fluid in cooling element

⁵⁾ Unfilled

Technical Data

ACA-LN / ACAF-LN

Type of cooler	Fluid [-] ¹⁾	Fluid flow [l/min]	Air flow [m³/h]	Pump displacement [cm³/U]	Max. viscosity [mm²/s] continuous working ²⁾	Pump motor: power / current absorption [kW/A] ³⁾		Fan motor: Poles / size / flange	Fan motor: power / current absorption [kW / A] ³⁾	Filter size [-]	Noise level (at 1 m distance, 50 Hz) [dB(A)]	Volume [l] ⁴⁾	Weight [kg] ⁵⁾
						40/58	69						

VERSION B: 50 Hz

ACA-LN8L	M	100/150/180	5,800	40/58/69	320/130/240	3.0 / 6.7	5.5 / 10.4	6/90/B14	0.75 / 2.0	-	68	6	102
ACA-LN8S	M	100/150/180	8,700	40/58/69	320/130/240	3.0 / 6.7	5.5 / 10.4	4/90/B14	1.5 / 3.3	-	79	6	102
ACAF-LN8L	M	100/150/180	5,800	40/58/69	320/130/240	3.0 / 6.7	5.5 / 10.4	6/90/B14	0.75 / 2.0	LPF280	68	6	110
ACAF-LN8S	M	100/150/180	8,700	40/58/69	320/130/240	3.0 / 6.7	5.5 / 10.4	4/90/B14	1.5 / 3.3	LPF280	79	6	110
ACA-LN9L	M	100/150/180	7,500	40/58/69	320/130/240	3.0 / 6.7	5.5 / 10.4	6/90/B14	0.75 / 2.0	-	67	11	132
ACA-LN9S	M	100/150/180	10,900	40/58/69	320/130/240	3.0 / 6.7	5.5 / 10.4	4/90/B14	1.5 / 3.3	-	80	11	132
ACAF-LN9L	M	100/150/180	7,500	40/58/69	320/130/240	3.0 / 6.7	5.5 / 10.4	6/90/B14	0.75 / 2.0	LPF280	67	11	140
ACAF-LN9S	M	100/150/180	10,900	40/58/69	320/130/240	3.0 / 6.7	5.5 / 10.4	4/90/B14	1.5 / 3.3	LPF280	80	11	140
ACA-LN10L	M	100/150/180	11,300	40/58/69	320/130/240	3.0 / 6.7	5.5 / 10.4	6/90/B14	1.1 / 2.65	-	71	14	172
ACA-LN10S	M	100/150/180	16,500	40/58/69	320/130/240	3.0 / 6.7	5.5 / 10.4	4/100/B14	3.0 / 6.0	-	77	14	172
ACAF-LN10L	M	100/150/180	11,300	40/58/69	320/130/240	3.0 / 6.7	5.5 / 10.4	6/90/B14	1.1 / 2.65	LPF280	71	14	180
ACAF-LN10S	M	100/150/180	16,500	40/58/69	320/130/240	3.0 / 6.7	5.5 / 10.4	4/100/B14	3.0 / 6.0	LPF280	77	14	180
ACA-LN11L	M	100/150/180	17,400	40/58/69	320/130/240	3.0 / 6.7	5.5 / 10.4	6/112/B14	2.2 / 4.6	-	75	18	212
ACA-LN11S	M	100/150/180	23,600	40/58/69	320/130/240	3.0 / 6.7	5.5 / 10.4	4/112/B14	4.0 / 7.7	-	81	18	212
ACAF-LN11L	M	100/150/180	17,400	40/58/69	320/130/240	3.0 / 6.7	5.5 / 10.4	6/112/B14	2.2 / 4.6	LPF280	75	18	220
ACAF-LN11S	M	100/150/180	23,600	40/58/69	320/130/240	3.0 / 6.7	5.5 / 10.4	4/112/B14	4.0 / 7.7	LPF280	81	18	220

VERSION C: 60 Hz

ACA-LN8L	M	120/180/215	6,150	40/58/69	320/130/240	3.0 / 6.7	5.5 / 10.4	6/90/B14	0.9 / 2.0	-	71	6	102
ACA-LN8S	M	120/180/215	8,700	40/58/69	320/130/240	3.0 / 6.7	5.5 / 10.4	4/90/B14	1.8 / 3.3	-	83	6	102
ACAF-LN8L	M	120/180/215	6,150	40/58/69	320/130/240	3.0 / 6.7	5.5 / 10.4	6/90/B14	0.9 / 2.0	LPF280	71	6	110
ACAF-LN8S	M	120/180/215	8,700	40/58/69	320/130/240	3.0 / 6.7	5.5 / 10.4	4/90/B14	1.8 / 3.3	LPF280	83	6	110
ACA-LN9L	M	120/180/215	7,500	40/58/69	320/130/240	3.0 / 6.7	5.5 / 10.4	6/90/B14	0.9 / 2.0	-	70	11	132
ACA-LN9S	M	120/180/215	10,900	40/58/69	320/130/240	3.0 / 6.7	5.5 / 10.4	4/90/B14	1.8 / 3.3	-	83	11	132
ACAF-LN9L	M	120/180/215	7,500	40/58/69	320/130/240	3.0 / 6.7	5.5 / 10.4	6/90/B14	0.9 / 2.0	LPF280	70	11	140
ACAF-LN9S	M	120/180/215	10,900	40/58/69	320/130/240	3.0 / 6.7	5.5 / 10.4	4/90/B14	1.8 / 3.3	LPF280	83	11	140
ACA-LN10L	M	120/180/215	12,000	40/58/69	320/130/240	3.0 / 6.7	5.5 / 10.4	6/90/B14	1.3 / 2.7	-	74	14	172
ACA-LN10S	M	120/180/215	16,400	40/58/69	320/130/240	3.0 / 6.7	5.5 / 10.4	4/100/B14	3.6 / 7.2	-	80	14	172
ACAF-LN10L	M	120/180/215	12,000	40/58/69	320/130/240	3.0 / 6.7	5.5 / 10.4	6/90/B14	1.3 / 2.7	LPF280	74	14	180
ACAF-LN10S	M	120/180/215	16,400	40/58/69	320/130/240	3.0 / 6.7	5.5 / 10.4	4/100/B14	3.6 / 7.2	LPF280	80	14	180
ACA-LN11L	M	120/180/215	18,300	40/58/69	320/130/240	3.0 / 6.7	5.5 / 10.4	6/112/B14	2.6 / 4.6	-	78	18	212
ACA-LN11S	M	120/180/215	23,600	40/58/69	320/130/240	3.0 / 6.7	5.5 / 10.4	4/112/B14	4.8 / 8.0	-	84	18	212
ACAF-LN11L	M	120/180/215	18,300	40/58/69	320/130/240	3.0 / 6.7	5.5 / 10.4	6/112/B14	2.6 / 4.6	LPF280	78	18	220
ACAF-LN11S	M	120/180/215	23,600	40/58/69	320/130/240	3.0 / 6.7	5.5 / 10.4	4/112/B14	4.8 / 8.0	LPF280	84	18	220

¹⁾ Medium: F = mineral oil or water-glycol, M = mineral oil

²⁾ Depends on pump displacement

³⁾ Current requirement: B version at 400 V – 50 Hz / C version at 480 V – 60 Hz

⁴⁾ Fluid in cooling element

⁵⁾ Unfilled

Cooling in bypass flow: ACA-LN / ACAF-LN

The ACA-LN with integrated boost pump is a complete bypass flow cooling system; the ACAF-LN is equipped with a high-quality HYDAC filter for additional filtration.

Advantages:

- Stable cooling and filtration (independent of the cycle times of the system)
- Continuous filtration is possible, cooling as required
- Avoidance of pressure surges in the cooling element
- Design of the cooler is in accordance with the cooling capacity required (not according to the maximum possible return flow volume)

Cooling Capacity and Pressure Difference Δp

Mineral oil

AC-LN / ACA-LN / ACAF-LN

50 Hz / 60 Hz

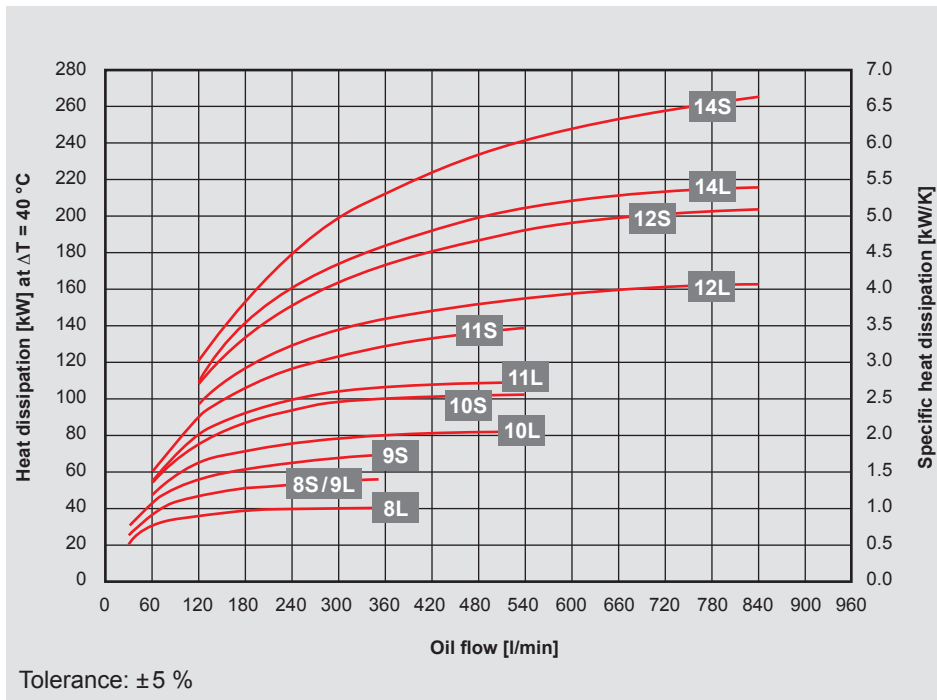

Cooling capacity:

Dependent on the oil flow rate and the temperature difference ΔT between oil inlet and air inlet.

Note:

The values are measured at $\Delta T = 40^\circ\text{C}$. For smaller ΔT values, the values can change. You can also use our cooler calculation software for designing. Please contact our technical sales department.

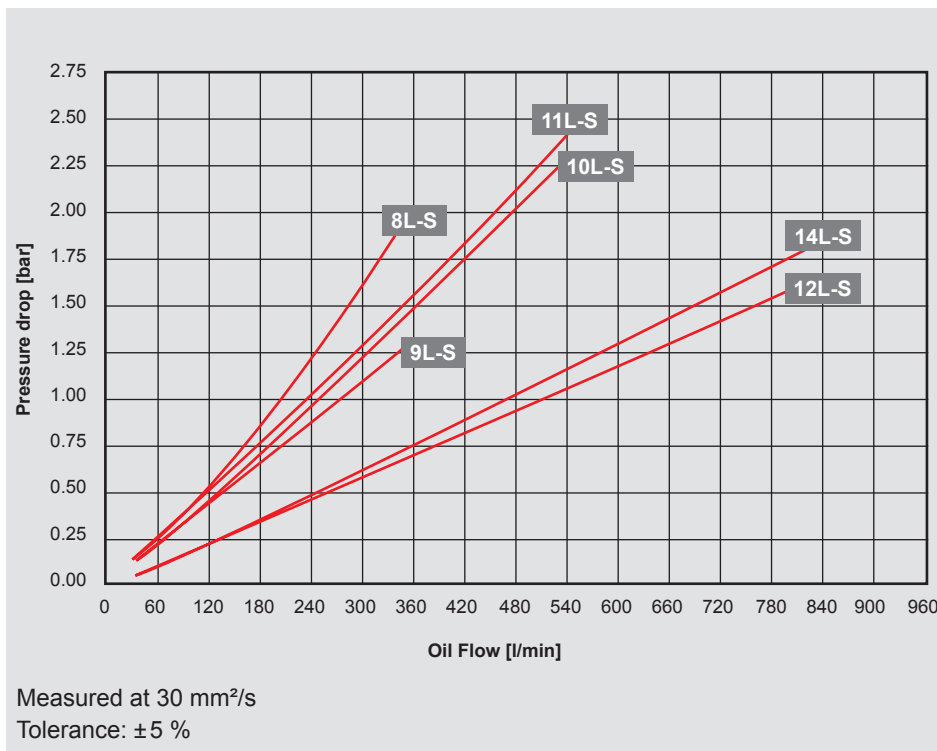

Pressure difference Δp

For other viscosities, the pressure loss must be multiplied by the conversion factor K:

Viscosity (mm^2/s)	10	15	22	30	46	68	100	150
Factor K	0.35	0.5	0.75	1	1.4	1.9	2.5	3.5

Cooling Capacity and Pressure Difference Δp

Water-glycol (60/40)

AC-LN

50 Hz / 60 Hz

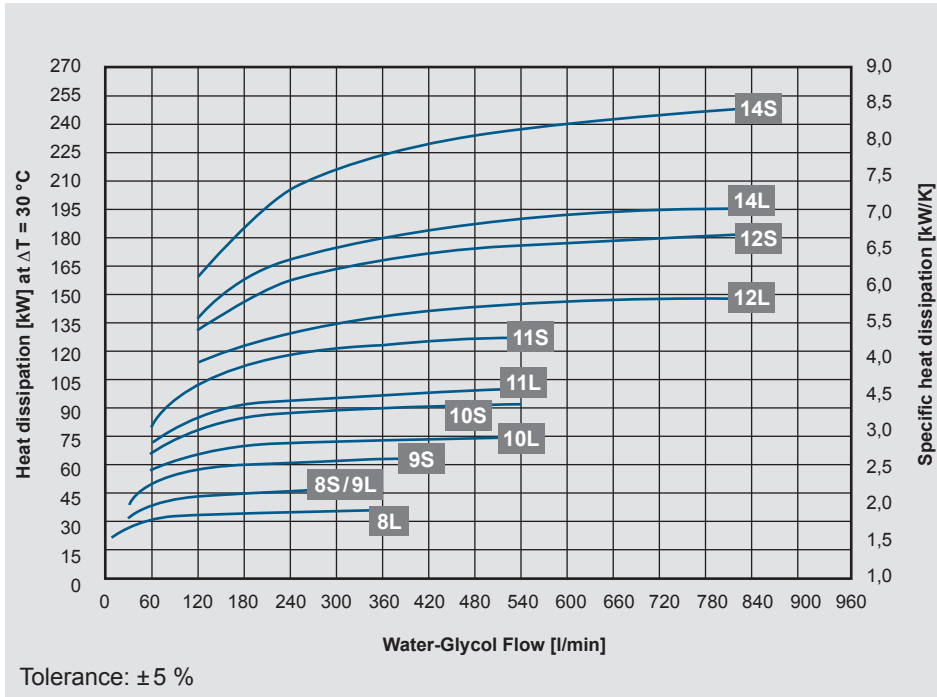

Cooling capacity:

Dependant on the water-glycol flow rate and the temperature difference ΔT between w/g inlet and air inlet.

Note:

The values are measured at $\Delta T = 30^\circ\text{C}$. For smaller ΔT values, the values can change. You can also use our cooler calculation software for designing. Please contact our technical sales department.

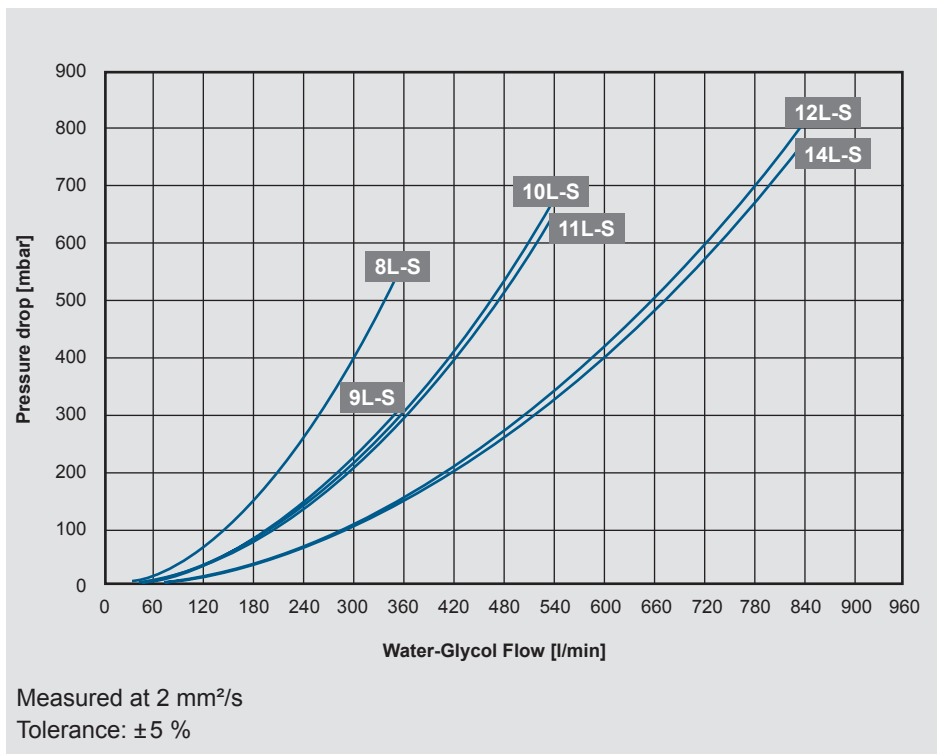

Pressure difference Δp

Model Typ

ACAF - LN8S - 40 - 1.0 - B - M - B - LPF280 - 10 - 1 - IBT

Cooler type

- AC-LN = Air cooler (oil / water-glycol mix)
- ACA-LN = Air cooler (oil) with integrated pump
- ACAF-LN = Air cooler (oil) with integrated pump and filter

Size / motor speed

- 8-14 = Size
- L = 6 poles (1,000 rpm)
- S = 4 poles (1,500 rpm)

Displacement cm³/rev

40/58/69 (only ACA-LN/ACAF-LN 8-11)

Revision

Clogging indicators (only ACAF-LN)

- A = Without clogging indicator
- B = With visual indicator (Standard)
- D = With electrical and optical indicator (24 V)

Fluids

- F = Mineral oil or water glycol mix (AC-LN)
- M = Mineral oil (ACA-LN and ACAF-LN)

Motor voltage

Standard voltages and frequencies for 3 phase motor

- B = 230/400 V – 50 Hz
 - C = 276/480 V – 60 Hz
 - A = Special version 230/400 V – 50 Hz + 276/480 V – 60 Hz
(tolerance voltage ± 10 %)
- Other voltages on request

Size of filter (only ACAF-LN)

ACAF-LN8-11 = LPF280

Filtration rating in micron (only ACAF-LN)

- 5 = 5 µm Betamicron®-4-N (5 BN4HC)
- 10 = 10 µm Betamicron®-4-N (10 BN4HC) (standard)
- 20 = 20 µm Betamicron®-4-N (20 BN4HC)

Color

- 1 = RAL 9002 (standard)
- Other colors on request.

Accessories

- IBP = Heat exchanger with integrated bypass valve
- IBT = Heat exchanger with integrated thermo-bypass valve
- AITF = Thermostat (fixed)

For all possible accessories, like vibration absorber, air filter grid or air filter mat please refer to brochure Accessories for air coolers.

Dimensions

AC-LN 8-9-10-11

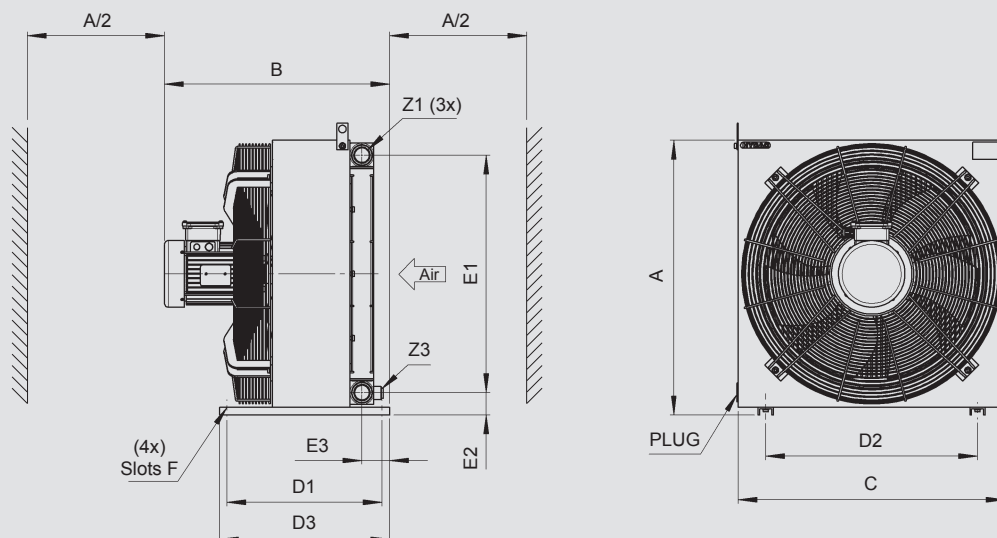

AC-LN 12-14

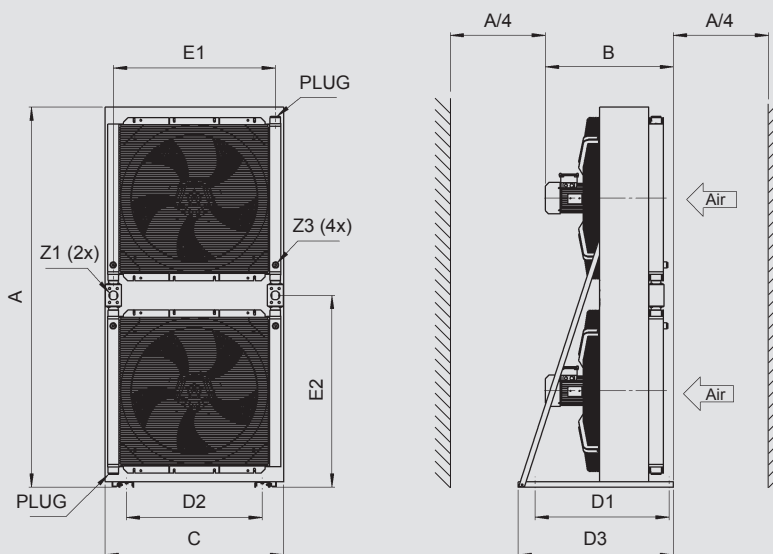

	A ±10	B ±25	C ±10	D1 ±2	D2 ±2	D3 ±2	E1 ±5	E2 ±5	E3 ±5	F ø Slots	Z1	Z2
AC-LN8 L	725	596	705	410	560	450	627	58	74	9x20	G1¼"	M22x1.5
AC-LN8 S	725	626	705	410	560	450	627	58	74	9x20	G1¼"	M22x1.5
AC-LN9 L	880	750	790	750	700	790	757	76.5	148	12	G1½"	M22x1.5
AC-LN9 S	880	780	790	750	700	790	757	76.5	148	12	G1½"	M22x1.5
AC-LN10 L	1,030	766	930	750	700	790	907	76.5	147	12	G1½"	M22x1.5
AC-LN10 S	1,030	787	930	750	700	790	907	76.5	147	12	G1½"	M22x1.5
AC-LN11 L	1,180	811	1,050	750	700	790	1,057	76.5	147	12	G1½"	M22x1.5
AC-LN11 S	1,180	810	1,050	750	700	790	1,057	76.5	147	12	G1½"	M22x1.5
AC-LN12 L	2,130	718	1,000	750	760	870	907	1,075	-	13x30	SAE2"	M22x1.5
AC-LN12 S	2,130	738	1,000	750	760	870	907	1,075	-	13x30	SAE2"	M22x1.5
AC-LN14 L	2,297	763	1,140	750	900	870	1,057	1,166	-	13x30	SAE2"	M22x1.5
AC-LN14 S	2,297	761	1,140	750	900	870	1,057	1,166	-	13x30	SAE2"	M22x1.5

Dimensions

ACA-LN 8-9-10-11

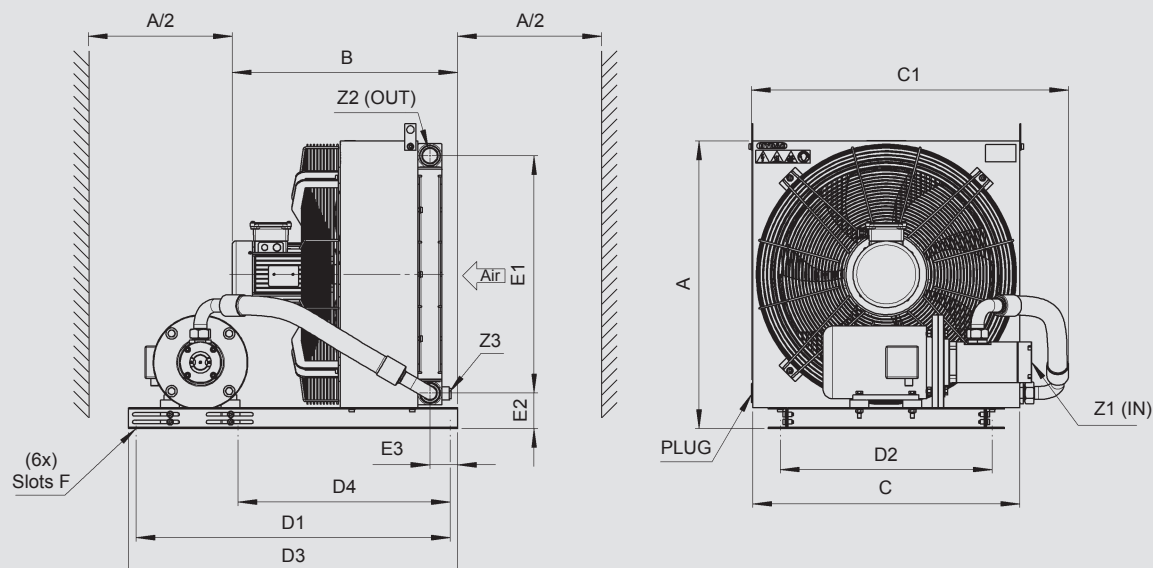

ACAF-LN 8-9-10-11

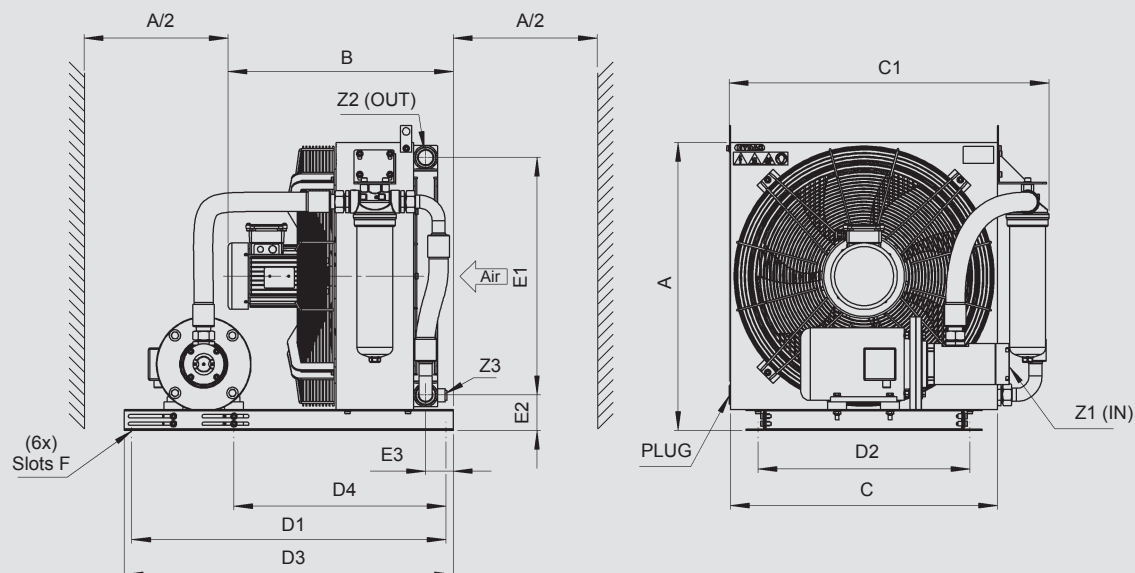

	A ±10	B ±25	C ±10	C1 ±25	D1 ±2	D2 ±2	D3 ±2	D4 ±2	E1 ±5	E2 ±5	E3 ±5	F Ø Slots	Z1 (IN)	Z2 (3x)	Z3
ACA-LN8L	760	596	705	837	830	560	870	560	627	94	74	9x20	G2"	G1 1/4"	M22x1.5
ACA-LN8S	760	626	705	837	830	560	870	560	627	94	74	9x20	G2"	G1 1/4"	M22x1.5
ACA-LN9L	905	730	790	914	830	700	870	560	757	102	128	9x20	G2"	G1 1/2"	M22x1.5
ACA-LN9S	905	760	790	914	830	700	870	560	757	102	128	9x20	G2"	G1 1/2"	M22x1.5
ACA-LN10L	1,055	746	930	1,053	830	700	870	560	907	102	127	9x20	G2"	G1 1/2"	M22x1.5
ACA-LN10S	1,055	767	930	1,053	830	700	870	560	907	102	127	9x20	G2"	G1 1/2"	M22x1.5
ACA-LN11L	1,205	791	1,050	1,164	830	700	870	560	1,057	102	127	9x20	G2"	G1 1/2"	M22x1.5
ACA-LN11S	1,205	790	1,050	1,164	830	700	870	560	1,057	102	127	9x20	G2"	G1 1/2"	M22x1.5
ACAF-LN8L	760	596	705	846	830	560	870	560	627	94	74	9x20	G2"	G1 1/4"	M22x1.5
ACAF-LN8S	760	626	705	846	830	560	870	560	627	94	74	9x20	G2"	G1 1/4"	M22x1.5
ACAF-LN9L	905	730	790	929	830	700	870	560	757	102	128	9x20	G2"	G1 1/2"	M22x1.5
ACAF-LN9S	905	760	790	929	830	700	870	560	757	102	128	9x20	G2"	G1 1/2"	M22x1.5
ACAF-LN10L	1,055	746	930	1,068	830	700	870	560	907	102	127	9x20	G2"	G1 1/2"	M22x1.5
ACAF-LN10S	1,055	767	930	1,068	830	700	780	560	907	102	127	9x20	G2"	G1 1/2"	M22x1.5
ACAF-LN11L	1,205	791	1,050	1,193	830	700	870	560	1,057	102	127	9x20	G2"	G1 1/2"	M22x1.5
ACAF-LN11S	1,205	790	1,050	1,193	830	700	870	560	1,057	102	127	9x20	G2"	G1 1/2"	M22x1.5

Note:

We recommend maintaining a minimum distance to ensure an unimpeded air inlet and air outlet. For sizes 8-11 this is half the height of the cooling element ($A/2$); for sizes 12-14 it is a quarter of the element height ($A/4$). Anything below the minimum distance can influence the cooling capacity and the noise emissions.

Note

The information in this brochure relates to the operating conditions and applications described.

For applications and operating conditions not described, please contact the relevant technical department.

Subject to technical modifications.



HYDAC COOLING GMBH

INTERNATIONAL

Industriegebiet
66280 Sulzbach/Saar
Germany

Tel.: +49 6897 509-01
Fax: +49 6897 509-454

E-mail: cooling@hydac.com
Internet: www.hydac.com

**HYDAC AG
Mezzovico Branch**

Via Sceresca, Zona Industriale 3
6805 Mezzovico
Switzerland

Tel.: +41 91 9355-700
Fax: +41 91 9355-701

E-mail: info@hydac.ch
Internet: www.hydac.com