

FEH35PQ

OPEN CENTER INLET MODULE WITH COMPENSATOR FOR FIXED DISPLACEMENT PUMPS

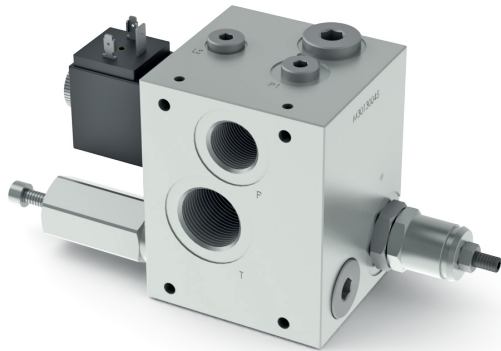

Connector to be ordered separately, see page 86.

ORDERING CODE

FEH35 Inlet module units with pressure relief valve and pressure compensator

P Electrical venting valve

Q Pressure compensator element

3 Size

***** Port P = G1/2"
Port T = G3/4"

C Adjustment:
C = Grub screw

***** Setting ranges:
1 = 35 ÷ 90 bar
2 = 75 ÷ 190 bar
3 = >150 bar

***** Voltage venting valve (1):
L = 12 Vdc
M = 24 Vdc
N = 48 Vdc
0 = Without electrical venting valve (plugged)

****** Variants (1-2):
S1 = No variants
SV = Viton
PY = Push button emergency (3)
PS = Rotary emergency (3)
AJ = AMP Junior connection 22W (see page 87)
CX = Deutsch connect. bidirectional diode (see page 87)

1 Serial No.

(1) Coils technical data, see page 87
Voltage codes are not stamped on the plate, their are readable on the coils
(2) Connector to be ordered separately, see page 86;
Other variants available on request.
(3) Emergency (see page 62)

Open center inlet module units FEH35PQ with adjustable compensator regulator for fixed displacement pumps with pressure relief valve CMP-MC/MS and electrical venting valve CRP04.

- Includes a pressure compensated load sensing signal bleed to minimize system losses even at high operating pressures. Signal bleed can be closed in case it not required.
- Manual adjustment with a grub screw.
- Threaded ports P G1/2"; T G3/4"
- Maximum flow 120 l/min.
- Cast iron zinc plated body.

HYDRAULIC SYMBOL

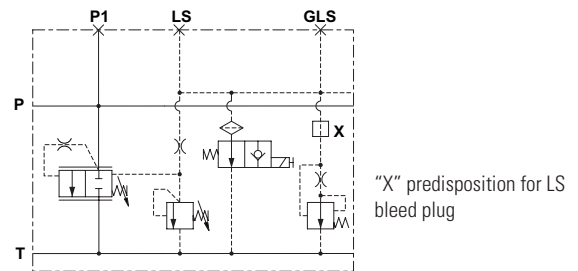

FEATURES

Max. operating pressure	310 bar
Setting ranges for pressure relief valve	Spring 1: 35 ÷ 90 bar Spring 2: 75 ÷ 190 bar Spring 3: >150 bar
Setting compensator regulator	10 ÷ 19 bar
Max. flow	120 l/min (see characteristic curves)
Fluid viscosity	10 ÷ 500 mm ² /s
Max LS bleed flow	0.5 l/min*
Fluid temperature	-25°C ÷ 75°C
Ambient temperature	-25°C ÷ 60°C
Max. contamination level (filter β ₂₅ ≥ 75)	ISO 4406:1999: class 21/19/16 NAS 1638: class 10
Weight	3.1 kg
Max. excitation frequency	2 Hz
Duty cycle	100% ED
Type of protection (in relation to the connection used)	IP65

To obtain a correct compensation the inlet flow must be 8% greater the sum of the regulated flows

* Bleed flow rate is subtracted to the energized valve working at the higher pressure. To avoid this behavior plug the bleed (see "X" on hydraulic scheme)

CHARACTERISTIC CURVE

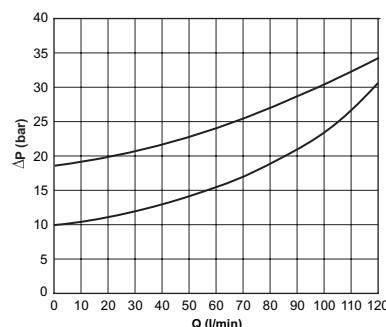

Pressure drops with compensator setting at 10 and 19 bar

FEH35PQ

OVERALL DIMENSIONS

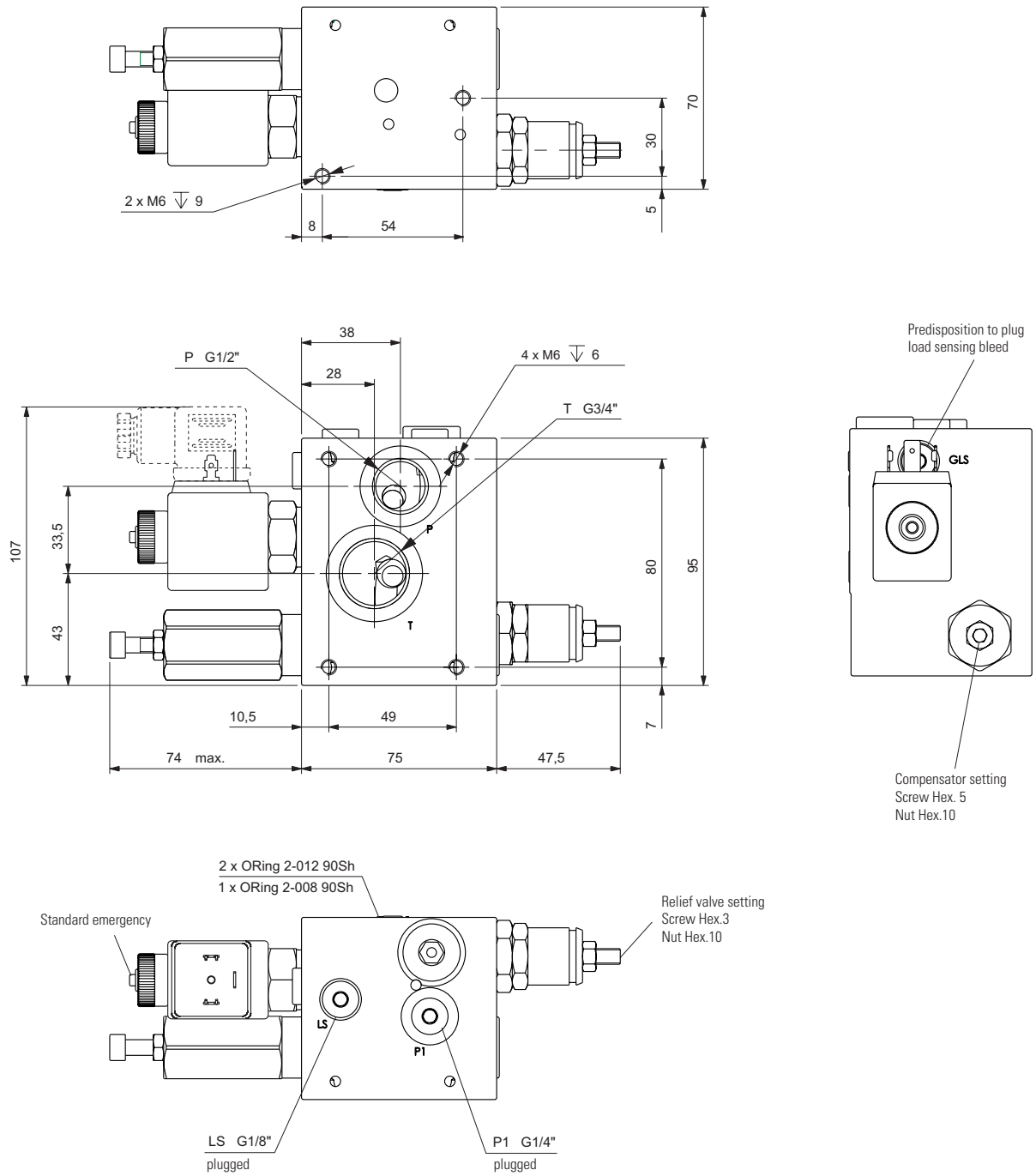

VARIANTS

"PS"
Emergency rotary

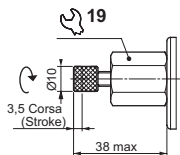

"PY"
Emergency with push button

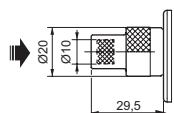

"AJ"
AMP Junior

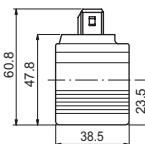

"CX"
Deutsch with diode

