

KRA.16/25... CARTRIDGE VALVES WITH ELECTRICAL POSITION CONTROL NG16 / NG25



This valve series is used in those applications where monitoring of the "actual" valve position is required for managing machine safety cycles as required by current accident prevention legislation. Typical examples of applications where this product is used include: hydraulic presses in general, plastic component injection and blow-form presses, die-casting presses.

The valve is composed of a closure cover where the inductive position monitoring proximity sensor is inserted to signal the two possible states of logic element manufactured to DIN 24342 standard.

This valve, in view of its being placed inside a safety system loop, can detect movement dangerous both for the safety of the operator and of the machine itself.

Availability of the CETOP 3 mounting interface on closure cover allows direct insertion of the piloting valves into the main valve, offering in this way to the designer the possibility to produce compact systems which can be easily mounted inside the machine.

KRA.16/25...

OVERALL DIMENSIONS	CH. V PAGE 13
KRA.16/25... + AD.3.V...	CH. V PAGE 14
PROXIMITY FOR KRA	CH. V PAGE 15
AD.3.V...	CH. I PAGE 13
"D15" DC COILS	CH. I PAGE 18
L.V.D.T. FOR AD.3.V	CH. I PAGE 21
STANDARD CONNECTORS	CH. I PAGE 19

ORDERING CODE

5

- KRA** Cartridge valve with electrical position control (logic element 2/2 incorporated)
- **** 16 = NG16
25 = NG25
- *** Calibrated orifices at ports A and P:
0 = no orifice
1 = Ø 1 mm dia opening (NG16 in standard configuration)
2 = Ø 1.2 mm dia opening (NG25 in standard configuration)
- *** Opening pressure (bar):
NG16 NG25
H = 4 (green spring) 3.5 (yellow spring)
J = 12 (no colour spring) 9 (blue spring)
- 00** No variant
- 1** Serial No.

HYDRAULIC SYMBOL

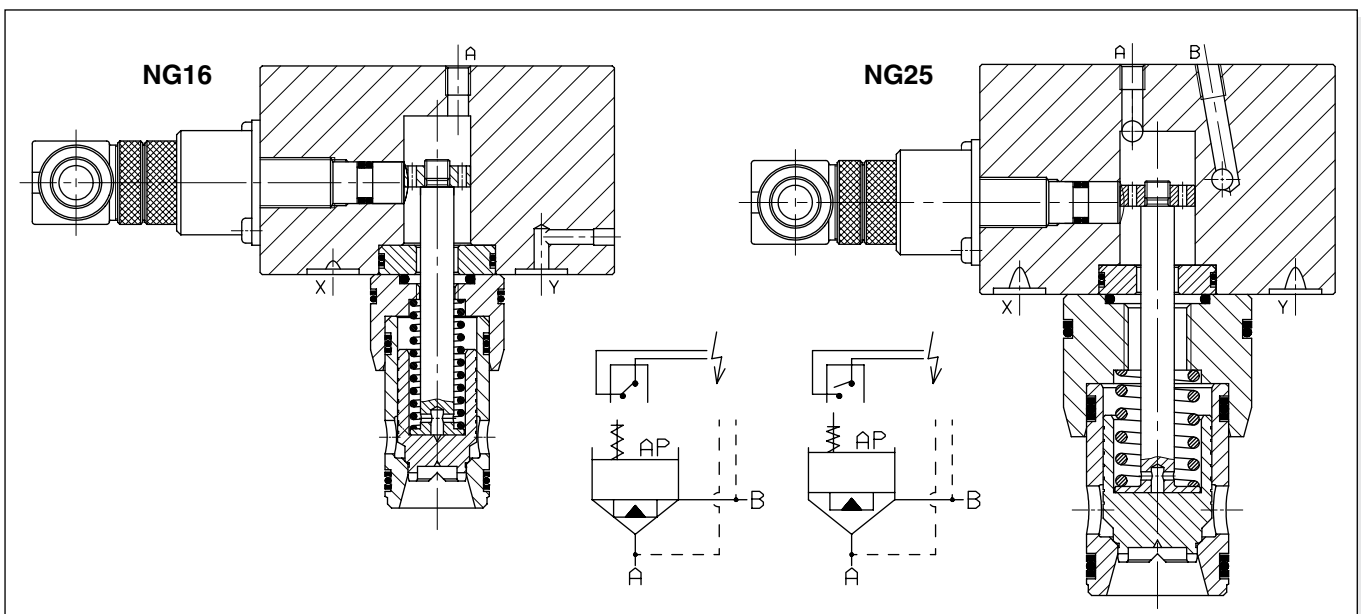
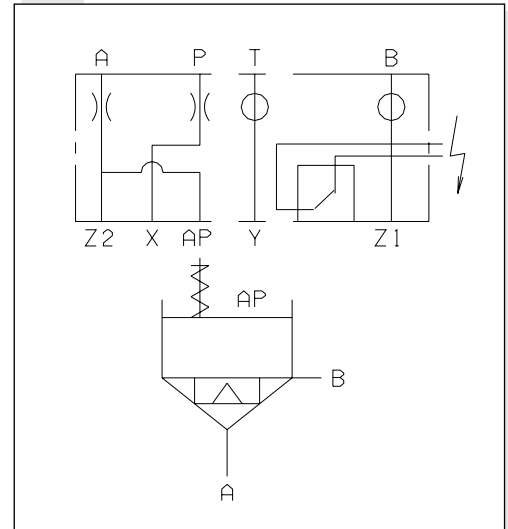

OVERALL DIMENSIONS KRA.16...

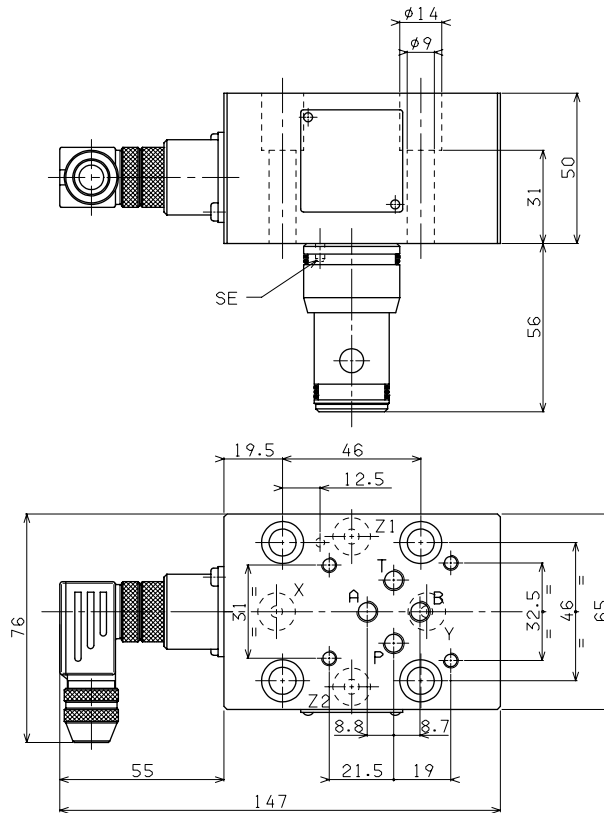

These covers are supplied complete with dowels and calibrated orifices on inputs A (AP) and P (X); mounting screws can be supplied on request.

Fixing screws T.C.E.I. M8X45 UNI 5931
 Reference pin dia ϕ 3X12 UNI 6873
 Screws S.T.E.I. M6X1X6 UNI 5923 dia ϕ 1mm
 Weight 2,2 Kg

5

OVERALL DIMENSIONS KRA.25...

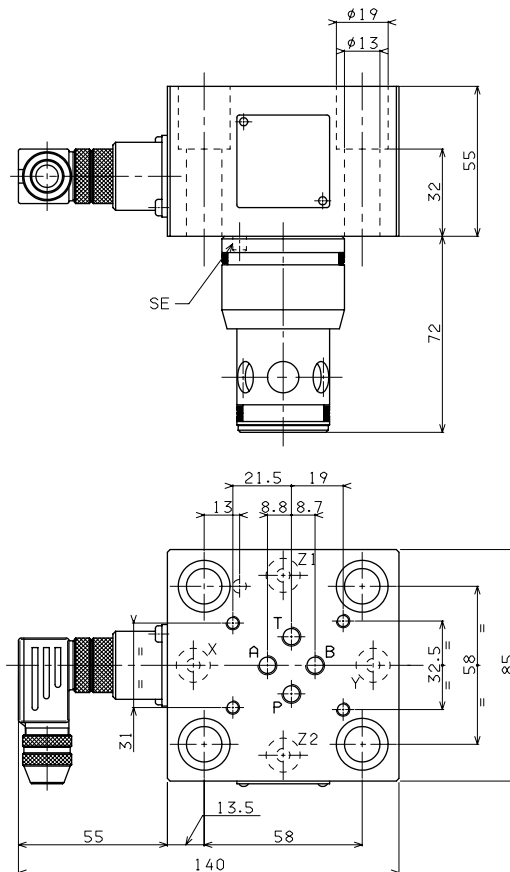

These covers are supplied complete with dowels and calibrated orifices on inputs A (AP) and P (X); mounting screws can be supplied on request.

Fixing screws T.C.E.I. M12X50 UNI 5931
 Reference pin dia ϕ 5X12 UNI 6873
 Screws S.T.E.I. M6X1X6 UNI 5923 dia ϕ 1.2mm
 Weight 3,42 Kg

KRA.16/25... + AD.3.V... 2/2 CARTRIDGE VALVES WITH ELECTRICAL POSITION CONTROL VALVE



KRA.16/25... + AD.3.V...

PROXIMITY FOR KRA	CH. V PAGE 15
AD.3.V...	CH. I PAGE 13
D15 DC COIL	CH. I PAGE 18
L.V.D.T. FOR AD.3.V	CH. I PAGE 21
STANDARD CONNECTORS	CH. I PAGE 19

This valve series is used in those applications where monitoring of the "actual" valve position is required for managing machine safety cycle as required by current accident prevention legislation.

Typical example of application where this product is used include: hydraulic presses in general, plastic components injection and blow-form presses, die-casting presses. The valve is composed of closure cover where the inductive position monitoring proximity sensor is inserted to signal the two possible states of logic element manufactured to DIN 24342 standard.

This valve, in view of its being placed inside a safety system loop, can detect movements dangerous both for the safety of the operator and of the machine itself. Use a single solenoid directional valve AD.3.V... as piloting unit allows increase in the safety system control level, since even the piloting unit is equipped with a position monitoring proximity sensor capable of signalling the two possible valve states.

HYDRAULIC SYMBOL

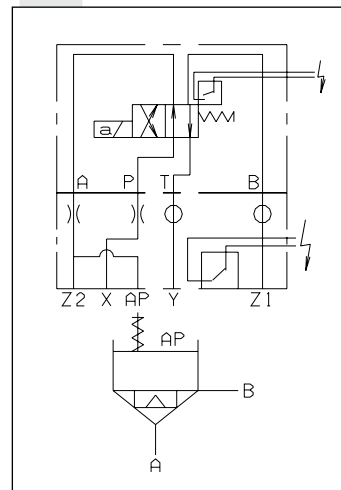

By combining these two monitoring systems it becomes possible to evaluate the hydraulic system response speed to prevent any possible malfunctioning or dangerous situations

5

These covers are supplied complete with dowel and calibrated orifices on inputs A (AP) /P (X); mounting screws can be supplied on request

KRA.16... + AD.3.V...

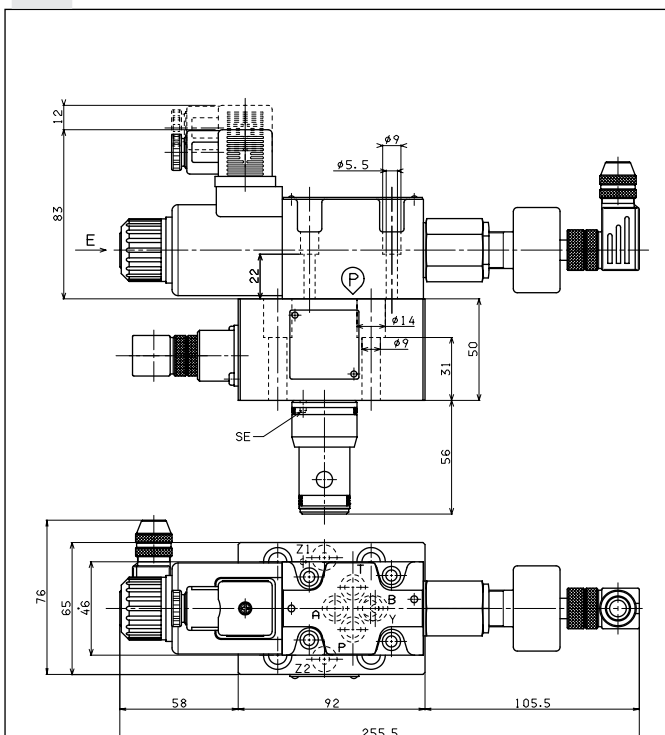

Fixing screws T.C.E.I. M8X45 UNI 5931

Reference pin dia ϕ 3X12 UNI 6873

Screw S.T.E.I. M6X1X6 UNI 5923 dia ϕ 1mm

KRA.25... + AD.3.V...

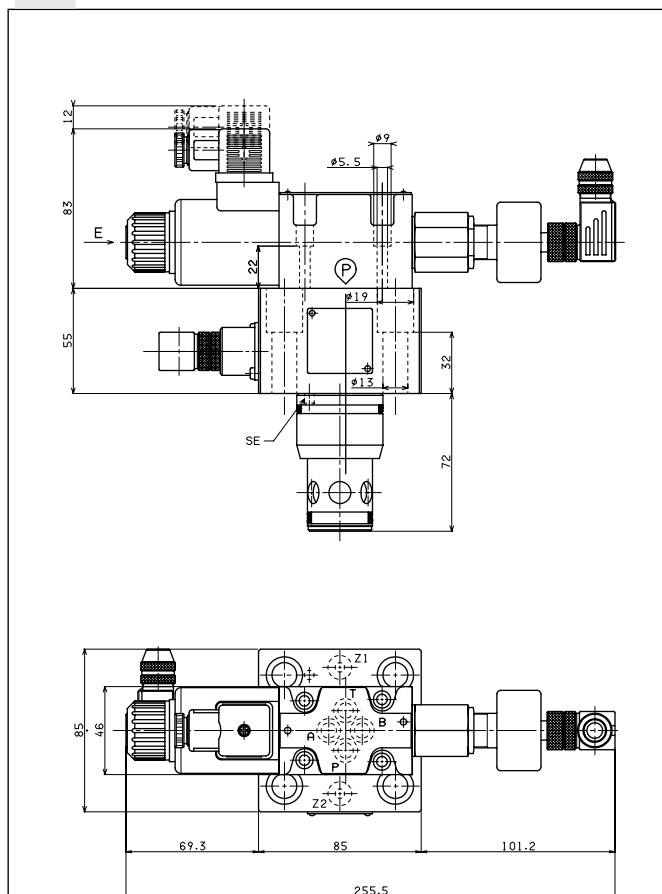

Fixing screws T.C.E.I. M12X50 UNI 5931

Reference pin dia ϕ 5X12 UNI 6873

Screw S.T.E.I. M6X1X6 UNI 5923 dia ϕ 1.2mm



The inductive proximity sensors make it possible to detect metal objects; the operating principle is based on a high frequency oscillator which produces an electromagnetic field in the immediate vicinity of the sensor.

The presence of a metal object (activator) inside the field dampens the amplitude of the oscillation because part of electromagnetic energy is transferred from the sensor to the activator and from there it is dissipated through the effect of the induced currents.

In addition to the shape and the dimensions of the sensor, its sensitivity also depends on the type of metal from which the activator is made.

SPECIFICATIONS

Max. pressure	500 bar
External diameter	M12x1
Release distance	0 ÷ 1.1 mm
Outlet function	PNP - NA
Stabilized supply	10 ÷ 30 VDC
Release hysteresis	≤ 0.2 mm
Type of mounting	wire
Max. current supplied	130 mA
Residual undulation	≤ 15%
Max switching frequency	1000 Hz
Casing material	stainless steel
Type of attachment	connector
Degree of protection	IP68 on active surface
Ambient temperature	-25°C ÷ 70°C
Protection against short circuit	yes

CONNECTION WIRING DIAGRAM

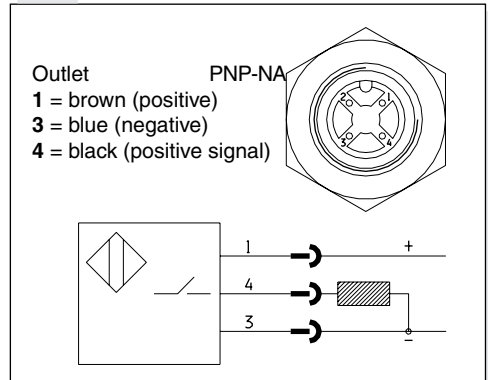

5

HOUSING AND SENSOR OVERALL DIMENSIONS

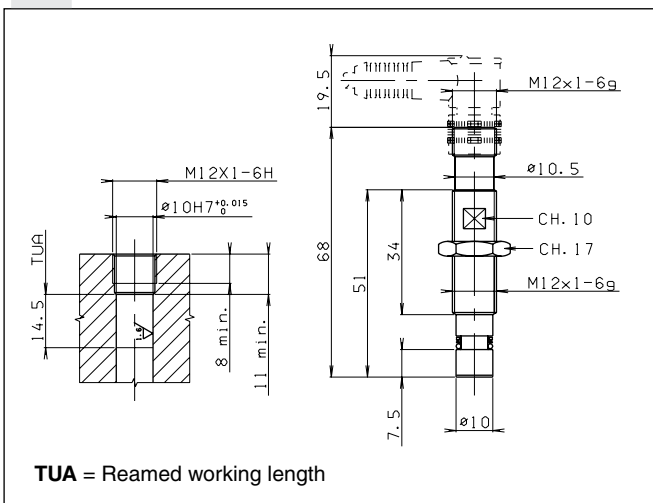

OVERALL DIMENSIONS CONNECTOR

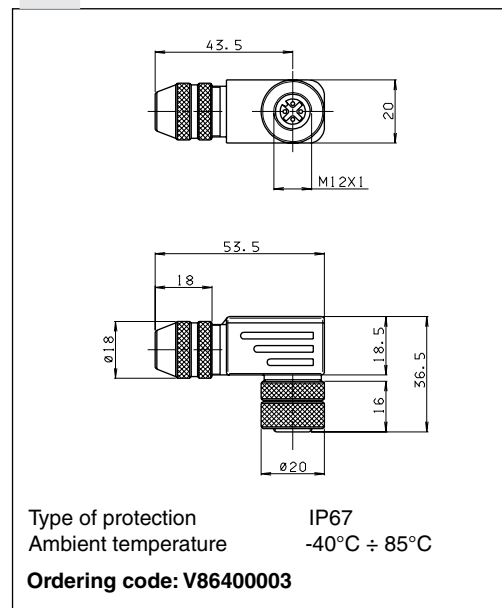

5