

## QCV.3.2... 2 WAY COMPENSATED FLOW RATE REGULATORS WITH ADJUSTABLE $\Delta P$

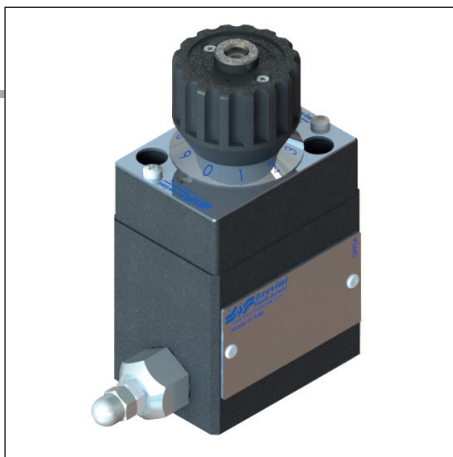

QCV.3.2...

Compensated flow regulators with antijump system and adjustable differential pressure can be defined as hydraulic power control units. Their design is suitable to circuits in which the flow rate has to be automatically operated as a function of the actuator working pressure.

For application requirements, please contact our technical service that can help you to choose the right valve and use it properly.

Max. operating pressure	320 bar
Nominal regulated flow rate	1 ÷ 24 l/min
Hydraulic fluids	Mineral oils DIN 51524
Fluid temperature	-25°C ÷ 75°C
Ambient temperature	-25°C ÷ 60°C
Fluid viscosity	10 ÷ 500 mm <sup>2</sup> /s
Max. contamination level(*)	class 10 in accordance with NAS 1638 with filter $\beta_{25} \geq 75$
Weight	1.5 Kg

(\*) Max contamination level must be respect to obtain the right function of the valve

### ORDERING CODE

**QCV** Compensated flow rate regulated with adjustable  $\Delta p$

**3** CETOP 3/NG06

**2G** Pre-setting for external operating

**\*\*** Flow rate ranges  
**Q1** = 1.5 l/min  
**Q2** = 3 l/min  
**Q3** = 9 l/min  
**Q4** = 19 l/min  
**Q5** = 24 l/min

**\*** 1 = 1 turn version  
 4 = 4 turns version

**R** Internal check valve (omit if not required)

**\*\*** 00 = No variants  
 V1 = Viton  
 FS = Sintered filters (Q1/Q2 only)  
 KK = Version with tightening key

**5** Serial No

### HYDRAULIC SYMBOL

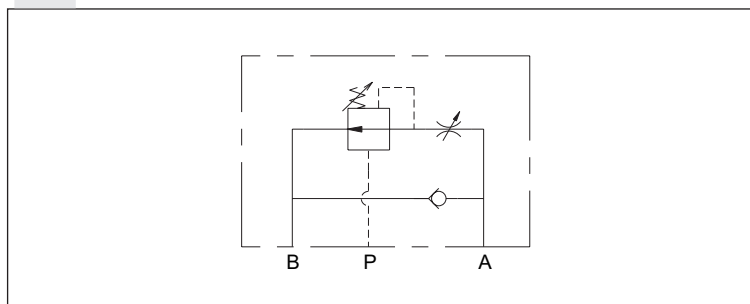

### OVERALL DIMENSIONS

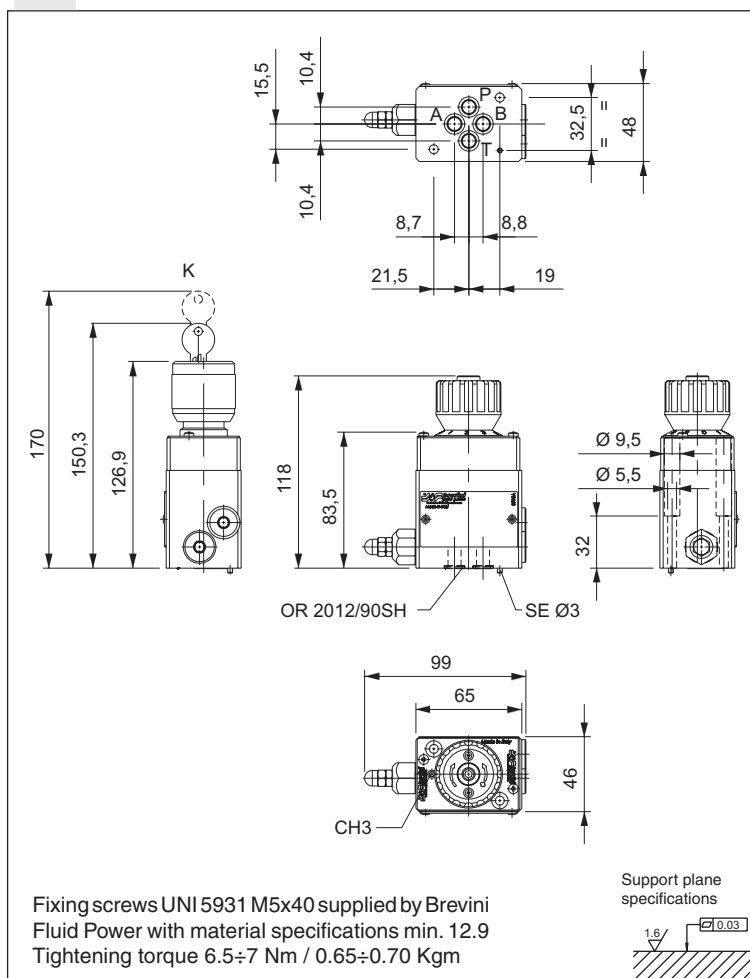

3