

CHECK VALVES FOR PIPES

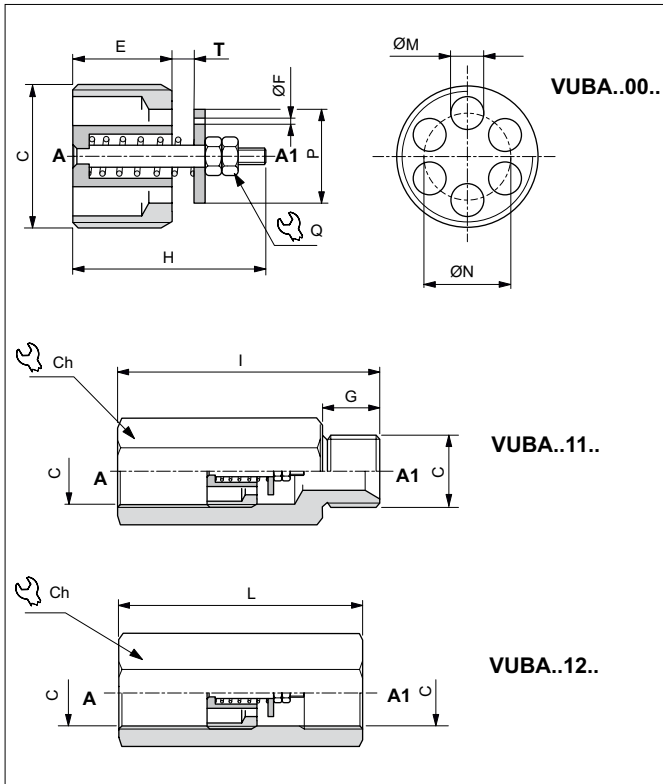

The pipe-pressure check valve is fitted directly on cylinder connections to prevent uncontrolled drops due to system faults. Supplied on request with a flow reducer hole F on the plate to enable leakage from A1 to A and allow the load to drop slowly. Steel body and plate. Seal surfaces lapped.

HYDRAULIC FEATURES

Max. Leakage (0 ÷ 5 drops/min)	0 ÷ 0.25 cm ³ /min
Hydraulic fluid	DIN 51524 Mineral oils
Fluid viscosity	10 ÷ 500 mm ² /s
Fluid temperature	-25°C ÷ 75°C
Ambient temperature	-25°C ÷ 60°C
Max. contamin. level class with filter	ISO 4406:1999 - class 19/17/14

HYDRAULIC SYMBOL

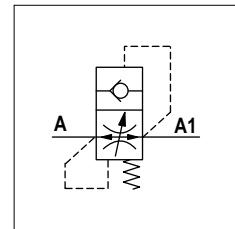

Code	C	Flow min (l/min)	Flow max (l/min)	Pressure max (bar)	E (mm)	F (mm)	G (mm)	H (mm)	I (mm)	L (mm)	M (mm)	N (mm)	P (mm)	Q (mm)	T* (mm)	Ch (mm)	Tightening torque (Nm)	Weight (kg)		
																		VUBA..00.	VUBA..11.	VUBA..12.
VUBA0400..	1/4 BSP	4	25	350	8	0.5 - 0.6	11	17.5	61	61	2.4	8.5	9.5	5.5	0.2 ÷ 1.0	19	2	0.007	0.07	0.09
VUBA0600 ..	3/8 BSP	6	50	350	10.5	0.8 - 1.0	13	23	63	63	3.5	10.5	12.5	5.5	0.2 ÷ 2.0	22	3	0.012	0.10	0.11
VUBA0800 ..	1/2 BSP	16	80	350	12	1.2 - 1.3	14	25	72	65	4.5	13	15	7	0.4 ÷ 2.6	27	4	0.023	0.17	0.16
VUBA1200 ..	3/4 BSP	25	150	350	17	1.5 - 1.9	17	30.5	104	72	6	16	18	7	0.3 ÷ 2.8	32	10	0.047	0.25	0.21

* Specify distance "T" with decimal progression. Standard distance "T" is 0.5 mm (for 1/4 and 3/8 BSP valves) and 0.7 mm (for 1/2 and 3/4 BSP valves). Response flow depends on distance "T" see "T adjustment curves".

DIAGRAMS FOR "T" ADJUSTEMENT

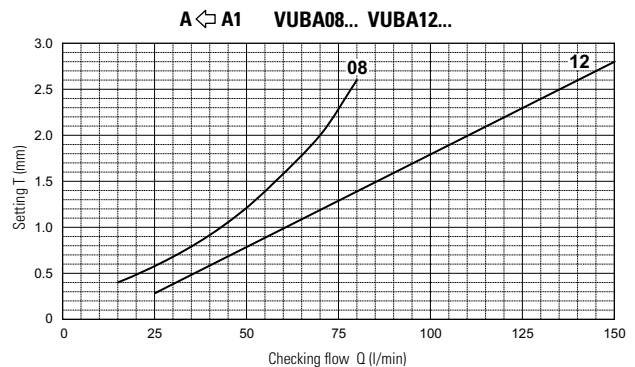
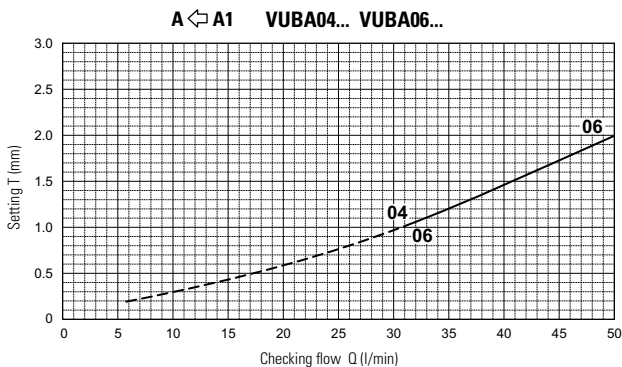

Distance "T" must correspond to a flow rate of at least 50% top than the set flow. The flow of checking flow may be ±10% on given curve. Fluid used: mineral based oil with viscosity 46 mm²/s at 40°C.

FLOW PRESSURE DROP ACCORDING ADJUSTEMENT "T"

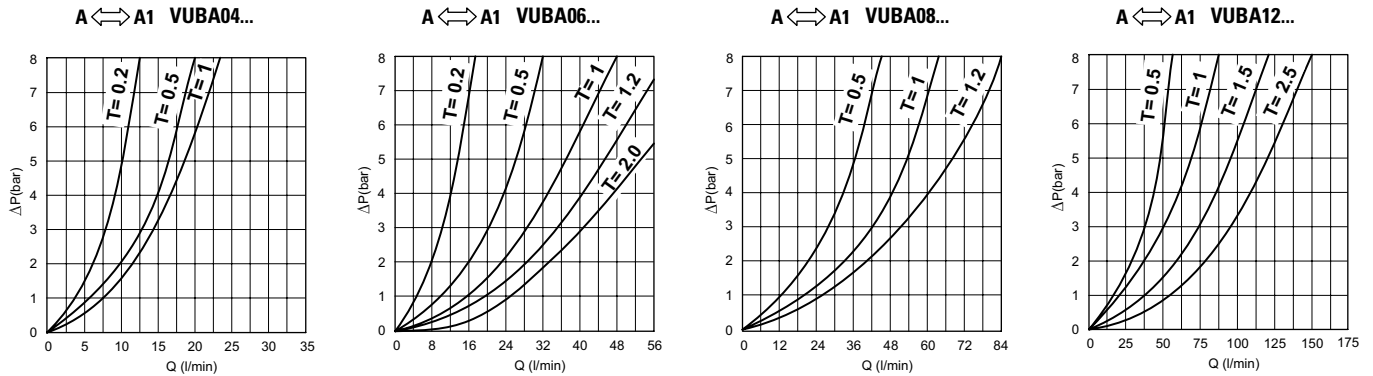

Diagrams flow pressure drop according adjustment length of "T"

KEY FOR TIGHTENING VALVE

Code key	For valve	D (mm)	L (mm)	L1 (mm)	L2 (mm)
AVA184	VUBA04..	11.3	120	110	60
AVA186	VUBA06..	15	120	110	80
AVA188	VUBA08..	18.8	120	108	80
AVA1812	VUBA12..	24	120	108	80

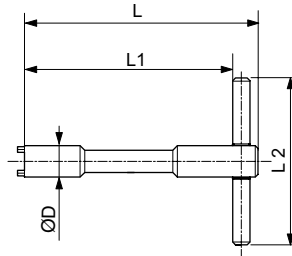

SERVICE EXAMPLE

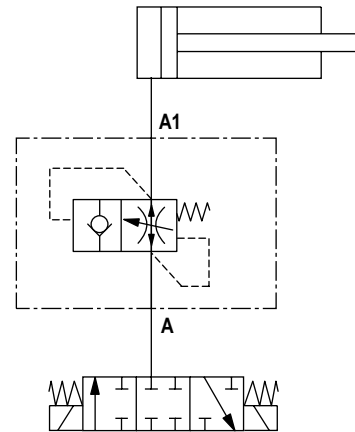

SEAL

C	H (mm)
1/4 BSP	11
3/8 BSP	11
1/2 BSP	15
3/4 BSP	16

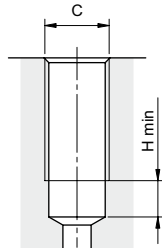

ORDERING CODE

VUBA	**	**	T***	F**
Series	Size	Versions	Setting T	Hole on the plate

VUBA = Check valve

04 = 1/4 BSP
06 = 3/8 BSP
08 = 1/2 BSP
12 = 3/4 BSP

00 = Cartridge only
11 = Complete valve M/F
12 = Complete valve F/F
01 = Only column M/F
02 = Only column F/F

NOTE:
(1-2) Special, minimum 100 pieces.
(2) Specify distance "T" with decimal progression (e.g. T020 = 0.20 mm).

Standard, without hole (omit code)	
Special holes (1)	
05 = 0.5 (mm)	13 = 1.3 (mm)
06 = 0.6 (mm)	15 = 1.5 (mm)
08 = 0.8 (mm)	19 = 1.9 (mm)
10 = 1.0 (mm)	20 = 2.0 (mm)
12 = 1.2 (mm)	

Standard settings (omit code)	
0.5 mm for dimensions 04-06	
0.7 mm for dimensions 08-12	

Special settings (2)	
020 ÷ 100 = 0.2 ÷ 1.0 mm for dimension 04	
020 ÷ 200 = 0.2 ÷ 2.0 mm for dimension 06	
040 ÷ 260 = 0.4 ÷ 2.6 mm for dimension 08	
030 ÷ 280 = 0.3 ÷ 2.8 mm for dimension 12	