

Hydraulic cylinders type **CKA** - for potentially explosive atmospheres

to 94/9/CE ATEX directive - ISO 6020-2 - nominal pressure 16 MPa (160 bar) - max 25 MPa (250 bar)

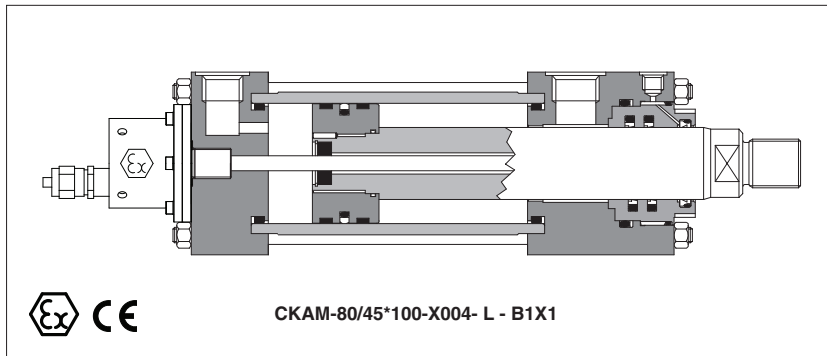

CKA cylinders are derived from standard CK (tab.B137) with certification according to ATEX 94/9/CE. They are designed to limit the external surface temperature, according to the certified class, to avoid the self-ignition of the explosive mixtures potentially present in the environment. CKAM servocylinders are equipped with ex-proof built-in digital magnetostrictive position transducer, ATEX certified.

- Optional ex-proof proximity sensors, ATEX certified
- Bore sizes from **25 to 200 mm**
- Up to **3** rod diameters per bore
- Strokes up to **5000 mm**
- Single or double rod
- **16** standard mounting styles
- **5** seals options
- Attachments for rods and mounting styles, **see tab. B500**

For cylinder's dimensions and options **see tab B.137**.
For cylinder's choice and sizing criteria **see tab. B015**.

1 ATEX CERTIFICATION

Cylinder type	Group	Equipment category	Gas group	Temperature class (1)	Zone
CKA	II	2 GD	II C	T85°C(T6)/T135°C(T4)	1,2,21,22
CKA + ex-proof rod position transducer (2)	II	2 G	II B	T6	1,2
	II	3 D	-	T85°C	22
CKA + ex-proof proximity sensors	II	3 G	II	T4	2

Notes: (1) Temperature class depends to the max fluid temperature and sealing system
(2) The rod position transducer is certified to work with explosive gas (cat. 2G) and dust (cat. 3D)

2 MODEL CODE

CKA M / 10 – 50 / 22 / 22* 0500 – S 3 0 1 – A – B1E3X1Z3 **

<p>CYLINDER SERIES CKA to ATEX 94/9/CE dimensions to ISO 6020 - 2</p>	<p>EX-PROOF POSITION TRANSDUCER See section 5 M = Digital magnetostrictive</p>	<p>INCORPORATED SUBPLATE (1) Omit if not requested 10 = size 06 20 = size 10 30 = size 16 40 = size 25</p>	<p>BORE SIZE (1) from 25 to 200 mm</p>																																					
<p>ROD DIAMETER (1) from 12 to 140 mm</p>	<p>SECOND ROD DIAMETER for double rod (1) Omit if not requested from 12 to 140 mm</p>	<p>STROKE (1) up to 5000 mm (4000 mm for CKAM)</p>	<p>MOUNTING STYLE (1)</p> <table style="width: 100%; border: none;"> <tr> <td style="width: 33%; border: none;"> <table border="0"> <tr> <td style="width: 50%;">C = fixed clevis</td> <td style="width: 50%;">P = rear flange</td> </tr> <tr> <td>D = fixed eye</td> <td>S = fixed eye + spherical bearing</td> </tr> <tr> <td>E = feet</td> <td>T = threaded hole+tie rods extended</td> </tr> <tr> <td>G = front trunnion</td> <td>V = rear tie rods extended</td> </tr> <tr> <td>H = rear trunnion</td> <td>W = both end tie rods extended</td> </tr> <tr> <td>K = feet with key (Ø 25÷63)</td> <td>X = basic execution</td> </tr> <tr> <td>L = intermediate trunnion</td> <td>Y = front tie rods extended</td> </tr> <tr> <td>N = front flange</td> <td>Z = front threaded holes</td> </tr> </table> </td> <td style="width: 33%; border: none;"> <table border="0"> <tr> <td style="width: 50%;">REF. ISO</td> <td style="width: 50%;">REF. ISO</td> </tr> <tr> <td>MP1 *</td> <td>ME6 *</td> </tr> <tr> <td>MP3 *</td> <td>MP5 *</td> </tr> <tr> <td>MS2</td> <td>MX7</td> </tr> <tr> <td>MT1</td> <td>MX2</td> </tr> <tr> <td>MT2 *</td> <td>MX1</td> </tr> <tr> <td>-</td> <td>-</td> </tr> <tr> <td>MT4**</td> <td>MX3</td> </tr> <tr> <td>ME5</td> <td>MX5</td> </tr> </table> </td> </tr> </table>	<table border="0"> <tr> <td style="width: 50%;">C = fixed clevis</td> <td style="width: 50%;">P = rear flange</td> </tr> <tr> <td>D = fixed eye</td> <td>S = fixed eye + spherical bearing</td> </tr> <tr> <td>E = feet</td> <td>T = threaded hole+tie rods extended</td> </tr> <tr> <td>G = front trunnion</td> <td>V = rear tie rods extended</td> </tr> <tr> <td>H = rear trunnion</td> <td>W = both end tie rods extended</td> </tr> <tr> <td>K = feet with key (Ø 25÷63)</td> <td>X = basic execution</td> </tr> <tr> <td>L = intermediate trunnion</td> <td>Y = front tie rods extended</td> </tr> <tr> <td>N = front flange</td> <td>Z = front threaded holes</td> </tr> </table>	C = fixed clevis	P = rear flange	D = fixed eye	S = fixed eye + spherical bearing	E = feet	T = threaded hole+tie rods extended	G = front trunnion	V = rear tie rods extended	H = rear trunnion	W = both end tie rods extended	K = feet with key (Ø 25÷63)	X = basic execution	L = intermediate trunnion	Y = front tie rods extended	N = front flange	Z = front threaded holes	<table border="0"> <tr> <td style="width: 50%;">REF. ISO</td> <td style="width: 50%;">REF. ISO</td> </tr> <tr> <td>MP1 *</td> <td>ME6 *</td> </tr> <tr> <td>MP3 *</td> <td>MP5 *</td> </tr> <tr> <td>MS2</td> <td>MX7</td> </tr> <tr> <td>MT1</td> <td>MX2</td> </tr> <tr> <td>MT2 *</td> <td>MX1</td> </tr> <tr> <td>-</td> <td>-</td> </tr> <tr> <td>MT4**</td> <td>MX3</td> </tr> <tr> <td>ME5</td> <td>MX5</td> </tr> </table>	REF. ISO	REF. ISO	MP1 *	ME6 *	MP3 *	MP5 *	MS2	MX7	MT1	MX2	MT2 *	MX1	-	-	MT4**	MX3	ME5	MX5	<p>HEADS' CONFIGURATION (1) (3) Oil ports positions B* = front head X* = rear head Cushioning adjustments positions, to be entered only if adjustable cushionings are selected E* = front head Z* = rear head * = selected position, (1, 2, 3 or 4)</p> <p>OPTIONS (3): Rod end (1) F = female thread G = light female thread H = light male thread Oversized oil ports (1) D = front oversized oil port Y = rear oversized oil port Ex-proof proximity sensors, see section 8 R = front sensor S = rear sensor Rod treatment (1) K = nickel and chrome plating T = induction surface hardening and chrome plating Air bleeds (1) A = front air bleed W = rear air bleed Draining (1) L = rod side draining</p> <p>SEALING SYSTEM, see section 7 1 = (NBR + POLYURETHANE) high static and dynamic sealing 2 = (FKM + PTFE) very low friction and high temperatures 4 = (NBR + PTFE) very low friction and high speeds 6 = (NBR + PTFE) very low friction, single acting - pushing 7 = (NBR + PTFE) very low friction, single acting - pulling</p> <p>SPACER (1) 0 = none 2 = 50 mm 4 = 100 mm 6 = 150 mm 8 = 200 mm</p> <p>CUSHIONINGS (1) 0 = none Fast adjustable 1 = rear only 2 = front only 3 = front and rear Slow adjustable 4 = rear only 5 = front only 6 = front and rear Fast fixed 7 = rear only 8 = front only 9 = front and rear</p>
<table border="0"> <tr> <td style="width: 50%;">C = fixed clevis</td> <td style="width: 50%;">P = rear flange</td> </tr> <tr> <td>D = fixed eye</td> <td>S = fixed eye + spherical bearing</td> </tr> <tr> <td>E = feet</td> <td>T = threaded hole+tie rods extended</td> </tr> <tr> <td>G = front trunnion</td> <td>V = rear tie rods extended</td> </tr> <tr> <td>H = rear trunnion</td> <td>W = both end tie rods extended</td> </tr> <tr> <td>K = feet with key (Ø 25÷63)</td> <td>X = basic execution</td> </tr> <tr> <td>L = intermediate trunnion</td> <td>Y = front tie rods extended</td> </tr> <tr> <td>N = front flange</td> <td>Z = front threaded holes</td> </tr> </table>	C = fixed clevis	P = rear flange	D = fixed eye	S = fixed eye + spherical bearing	E = feet	T = threaded hole+tie rods extended	G = front trunnion	V = rear tie rods extended	H = rear trunnion	W = both end tie rods extended	K = feet with key (Ø 25÷63)	X = basic execution	L = intermediate trunnion	Y = front tie rods extended	N = front flange	Z = front threaded holes	<table border="0"> <tr> <td style="width: 50%;">REF. ISO</td> <td style="width: 50%;">REF. ISO</td> </tr> <tr> <td>MP1 *</td> <td>ME6 *</td> </tr> <tr> <td>MP3 *</td> <td>MP5 *</td> </tr> <tr> <td>MS2</td> <td>MX7</td> </tr> <tr> <td>MT1</td> <td>MX2</td> </tr> <tr> <td>MT2 *</td> <td>MX1</td> </tr> <tr> <td>-</td> <td>-</td> </tr> <tr> <td>MT4**</td> <td>MX3</td> </tr> <tr> <td>ME5</td> <td>MX5</td> </tr> </table>	REF. ISO	REF. ISO	MP1 *	ME6 *	MP3 *	MP5 *	MS2	MX7	MT1	MX2	MT2 *	MX1	-	-	MT4**	MX3	ME5	MX5					
C = fixed clevis	P = rear flange																																							
D = fixed eye	S = fixed eye + spherical bearing																																							
E = feet	T = threaded hole+tie rods extended																																							
G = front trunnion	V = rear tie rods extended																																							
H = rear trunnion	W = both end tie rods extended																																							
K = feet with key (Ø 25÷63)	X = basic execution																																							
L = intermediate trunnion	Y = front tie rods extended																																							
N = front flange	Z = front threaded holes																																							
REF. ISO	REF. ISO																																							
MP1 *	ME6 *																																							
MP3 *	MP5 *																																							
MS2	MX7																																							
MT1	MX2																																							
MT2 *	MX1																																							
-	-																																							
MT4**	MX3																																							
ME5	MX5																																							

Notes:
(1) For details see **tab. B137**
(2) For spare parts request always indicate the series number printed on the nameplate
(3) To be entered in alphabetical order

3 CERTIFICATION

In the following are resumed the cylinders marking according to Atex certification. Reference norm UNI EN 13463.

Ex II 2GD ck IIC T85°C(T6)

GROUP II, Atex

Ex = Equipment for explosive atmospheres

II = Group II for surface plants

2 = High protection (equipment category)

GD = For gas, vapours and dust

c,k = Protection by constructional safety and by liquid immersion

IIC = Gas group

T85°C/T135°C = Surface temperature class for dust

T6/T4 = Surface temperature class for gas, see section 6

Zone 1 (gas) and 21 (dust) = Possibility of explosive atmospheres during normal functioning

Zone 2 (gas) and 22 (dust) = Low probability of explosive atmospheres

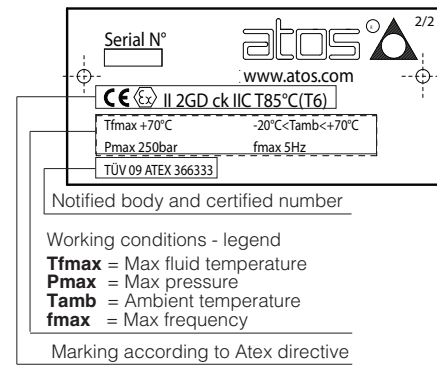

4 INSTALLATION NOTES

Before installation and start-up refer to tab. B600

- The max surface temperature indicated in the nameplate must be lower than the following values:

GAS - **80% of gas ignition temperature**

DUST - max value between **dust ignition temperature - 75°C** and **2/3 of dust ignition temperature**

- The ignition temperature of the fluid must be 50°C greater than the maximum surface temperature indicated in the nameplate

- The cylinder must be grounded using the threaded hole on the rear head, evidenced by the nameplate with ground symbol. The hydraulic cylinder must be put at the same electric potential of the machine

GROUNDING

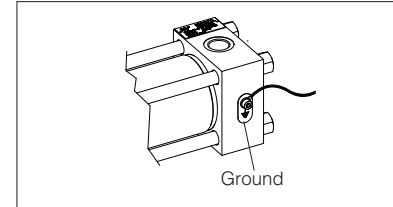

5 EX-PROOF ROD POSITION TRANSDUCER

CODE: M

CKA cylinders are available with "Balluff" Ex-proof rod position transducer, ATEX certified to **II 1/2 G Ex d IIB+H₂ T6 X** for gas and **Ex td IP67 T85°C** for dust. Ex-proof transducers meet the requirements of the following european standard documentations:

II 1/2 G Ex d IIB + H₂ T6 X

EN 60079-0

EN 60079-1

EN 60079-26

Ex td IP67 T85°C

EN 61241-0

EN 61241-0/AA

EN 61241-1

The transducer housing is made in AISI 303.

For dimensions and details, contact our technical office.

For certification and start-up refer to the user's guide included in the supply

CKAM WITH ROD POSITION TRANSDUCER

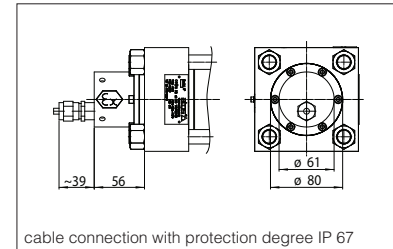

6 MAIN CHARACTERISTICS AND FLUID REQUIREMENTS

Ambient temperature	-20 ÷ +70°C
Fluid temperature	-20 ÷ +70°C (T6); -20 ÷ +120°C (T4) for seals type 2 (*) -20 ÷ +60°C for CKAM
Max surface temperature	≤ +85 °C (T6); ≤ +135 °C (T4) for seals type 2 (*)
Max working pressure	16 MPa (160 bar)
Max pressure	25 MPa (250 bar)
Max frequency	5 Hz
Max speed (see section 7)	1 m/s (seals type 2, 4, 6, 7); 0,5 m/s (seals type 1)
Recommended viscosity	15 ÷ 100 mm ² /s
Fluid contamination class according to ISO 4406	ISO 19/16 (achievable with in-line filters at 25 μm)

Note: (*) Cylinders with seals type 2 may also be certified T6 limiting the max fluid temperature to 70°C

CKA cylinders are suitable for operation with mineral oils with or without additives (**HH, HL, HLP, HLP-D, HM, HV**), fire resistant fluids (**HFA** oil in water emulsion - 90-95% water and 5-10% oil, **HFB** water in oil emulsion - 40% water, **HFC** water glycol - max 45% water) and synthetic fluids (**HFD-U** organic esters, **HFD-R** phosphate esters) depending to the sealing system.

7 SEALING SYSTEM FEATURES

The sealing system must be chosen according to the working conditions of the system: speed, operating frequencies, fluid type and temperature. Additional verifications about minimum in/out rod speed ratio, static and dynamic sealing friction are warmly suggested, see **tab. B015**.

When single acting seals are selected (types 6 and 7), the not pressurized cylinder's chamber must be connected to the tank. Contact our technical office for the compatibility with other fluids not mentioned below and specify type and composition.

Sealing system	Material	Features	Max speed [m/s]	Fluid temperature range	Fluids compatibility	ISO Standards for seals	
						Piston	Rod
1	NBR + POLYURETHANE	high static and dynamic sealing	0.5	-20°C to 70°C	Mineral oils HH, HL, HLP, HLP-D, HM, HV	ISO 7425/1	ISO 5597/1
2	FKM + PTFE	very low friction and high temperatures	1	-20°C to 120°C	Mineral oils HH, HL, HLP, HLP-D, HM, HV, fire resistance fluids HFA, HFB, HFD-U, HFD-R	ISO 7425/1	ISO 7425/2
4	NBR + PTFE	very low friction and high speeds	1	-20°C to 70°C	Mineral oils HH, HL, HLP, HLP-D, HM, HV, MIL-H-5606 fire resistance fluids HFA, HFC (water max 45%), HFD-U	ISO 7425/1	ISO 7425/2
6 - 7	NBR + PTFE	very low friction single acting - pushing/pulling	1	-20°C to 70°C	Mineral oils HH, HL, HLP, HLP-D, HM, HV, fire resistance fluids HFA, HFC (water max 45%), HFD-U	ISO 7425/1	ISO 7425/2

8 EX-PROOF PROXIMITY SENSORS

CODES: **R** = front sensor; **S** = rear sensor

CKA cylinders are available with ex-proof proximity sensors, ATEX certified to **Ex II 3G Ex nA II T4 X**. They meet the requirements of the following european standard documentations: EN 60079-0, EN 60079-15.

Their functioning is based on the variation of the magnetic field, generated by the sensor itself, when the cushioning piston enters on its influence area, causing a change of state (on/off) of the sensors. The sensor housing is made in stainless steel.

For dimensions and details, contact our technical office.

For certification and start-up refer to the user's guide included in the supply

SENSORS TECHNICAL DATA

Ambient temperature	-20 ÷ 70°C
Nominal voltage	24 VDC
Operating voltage	10 ÷ 30 VDC
Max load	200 mA
Repeatability	<5%
Protection degree	IP 68
Max frequency	1000 Hz
Max pressure	25 MPa