

Hydraulic cylinders type CK - square heads with tie rods

to ISO 6020-2 - nominal pressure 16 MPa (160 bar) - max 25 MPa (250 bar)

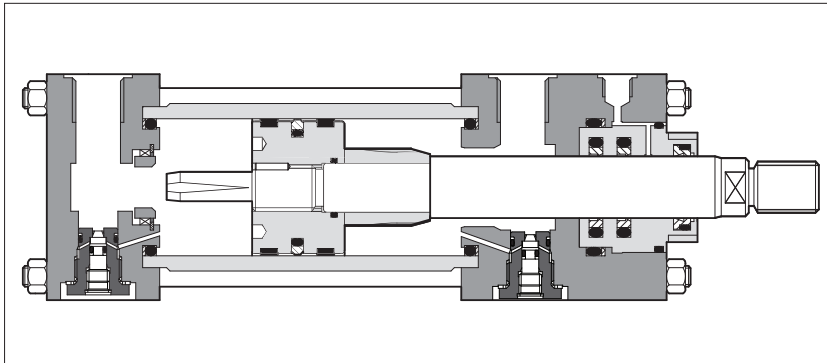

CK cylinders have engineered double acting construction, designed to suit the requirements of industrial applications: top reliability, high performances and long working life.

- Bore sizes from **25 to 200 mm**
- Up to **3** rod diameters per bore
- Strokes up to **5000 mm**
- Single or double rod
- Rods and tie rods with **rolled threads**
- **16** standard mounting styles
- **6** seals options
- Adjustable or fixed cushionings
- Optional built-in position transducer, **see tab. B310**
- Attachments for rods and mounting styles, **see tab. B500**

For cylinder's choice and sizing criteria **see tab. B015**.

SWC Cylinders Designer

Software for assisted selection of Atos cylinders & servocylinders codes, including cylinder's sizing, full technical information, 2D & 3D drawings in several CAD formats.

Download is available on www.atos.com

1 MODEL CODE

CK		P / 10 - 50 / 22 / 22* 0500 - S				3	0	1	- A -	B1E3X1Z3	**
CYLINDER SERIES CK to ISO 6020 - 2											Series number (1)
ROD POSITION TRANSDUCER F = magnetosonic M = magnetosonic programmable N = magnetostrictive P = potentiometric V = inductive Dimensions and performances see tab. B310											HEADS' CONFIGURATION (2), see section 13 Oil ports positions B* = front head X* = rear head Cushioning adjustments positions, to be entered only if adjustable cushionings are selected E* = front head Z* = rear head * = selected position, (1, 2, 3 or 4)
INCORPORATED SUBPLATE, see section 15 Omit if not requested 10 = size 06 20 = size 10 30 = size 16 40 = size 25											OPTIONS (2): Rod end, see section 6 F = female thread G = light female thread H = light male thread Oversized oil ports, see section 11 D = front oversized oil port Y = rear oversized oil port Proximity sensors, see section 18 R = front sensor S = rear sensor Rod treatment, see section 9 K = nickel and chrome plating T = induction surface hardening and chrome plating Air bleeds, see section 16 A = front air bleed W = rear air bleed Draining, see section 17 L = rod side draining
BORE SIZE, see section 3 from 25 to 200 mm											SEALING SYSTEM, see section 14 1 = (NBR + POLYURETHANE) high static and dynamic sealing 2 = (FKM + PTFE) very low friction and high temperatures 4 = (NBR + PTFE) very low friction and high speeds 6 = (NBR + PTFE) very low friction, single acting - pushing 7 = (NBR + PTFE) very low friction, single acting - pulling 8 = (NBR + PTFE and POLYURETHANE) low friction
ROD DIAMETER, see sections 6 and 9 from 12 to 140 mm											SPACER, see section 5 0 = none 2 = 50 mm 4 = 100 mm 6 = 150 mm 8 = 200 mm
SECOND ROD DIAMETER for double rod, see section 10 Omit if not requested from 12 to 140 mm											CUSHIONINGS, see section 12 0 = none Fast adjustable 1 = rear only 2 = front only 3 = front and rear Slow adjustable 4 = rear only 5 = front only 6 = front and rear Fast fixed 7 = rear only 8 = front only 9 = front and rear
STROKE, see section 4 up to 5000 mm. Quick deliveries available for selected strokes											
MOUNTING STYLE, see sections 2 and 3 C = fixed clevis D = fixed eye E = feet G = front trunnion H = rear trunnion K = feet with key (Ø 25÷63) L = intermediate trunnion N = front flange * Not available for double rod ** XV dimension must be indicated in the model code, see section 3 - note (5)		REF. ISO MP1 * MP3 * MS2 MT1 MT2 * - MT4** ME5				REF. ISO ME6 * MP5 * MX7 MX2 MX1 - MX3 MX5					

Notes:
 (1) For spare parts request always indicate the series number printed on the nameplate
 (2) To be entered in alphabetical order

2 MOUNTING STYLE - for dimensions see section **3**

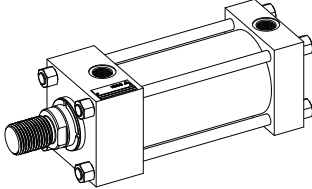
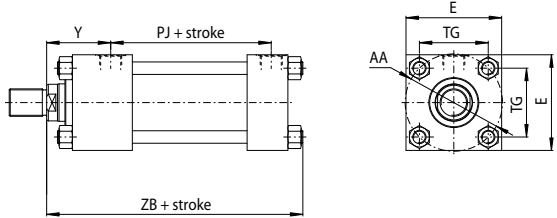
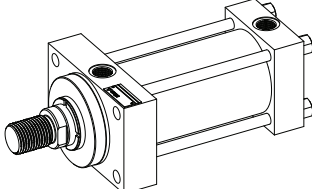
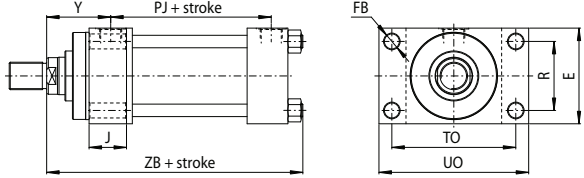
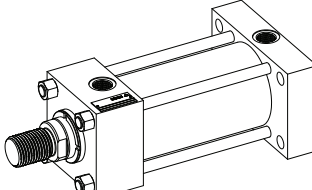
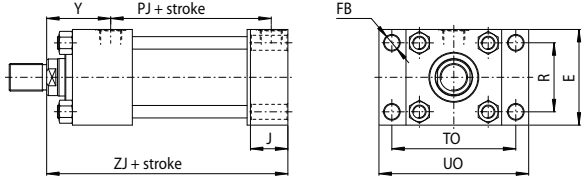
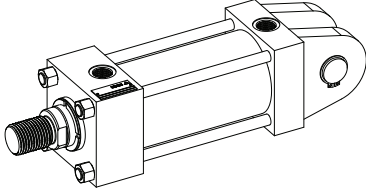
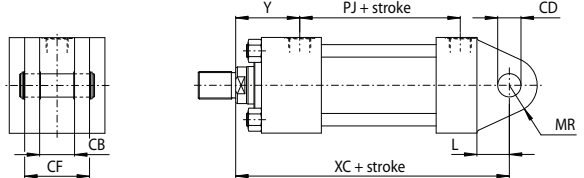
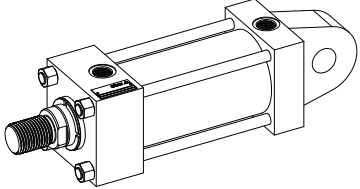
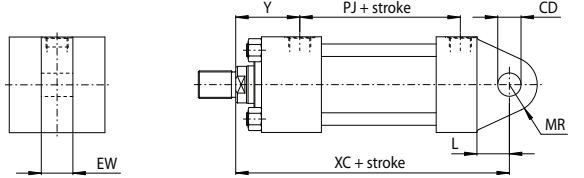
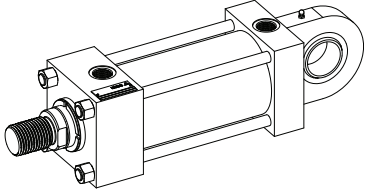
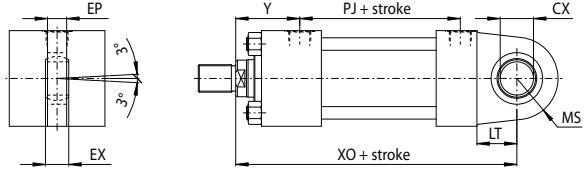
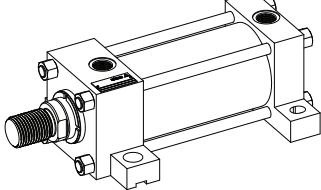
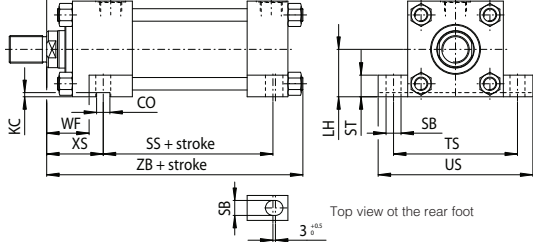
 <p>X = basic mounting</p>	
 <p>N (ISO ME5) = front flange mounting</p>	
 <p>P (ISO ME6) = rear flange mounting</p>	
 <p>C (ISO MP1) = fixed clevis mounting - supplied with pivot pin C-145</p>	
 <p>D (ISO MP3) = fixed eye mounting</p>	
 <p>S (ISO MP5) = fixed eye with spherical bearing mounting</p>	
 <p>E (ISO MS2) = side feet mounting</p>	 <p>Top view of the rear foot</p>

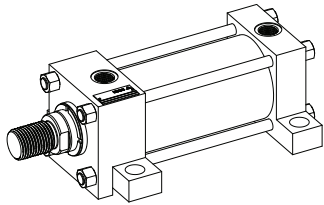

K = feet with key mounting (only for bores 25÷63)

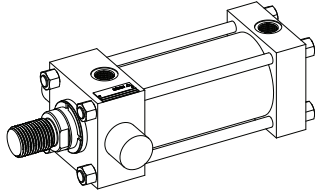
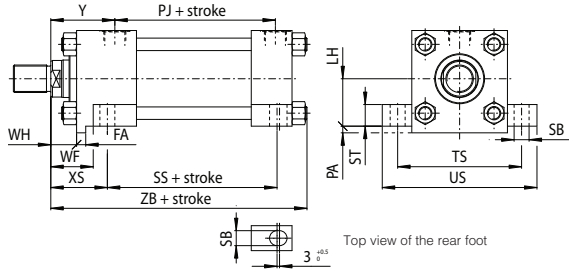

G (ISO MT1) = front trunnion mounting (*)
H (ISO MT2) = rear trunnion mounting
 (*) see figure

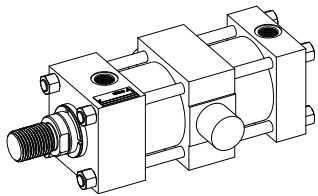
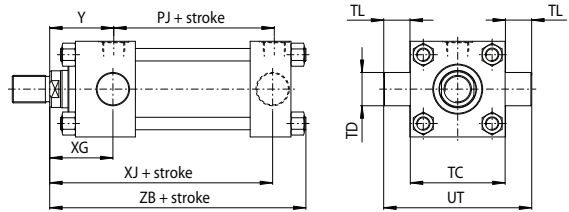

L (ISO MT4) = intermediate trunnion mounting

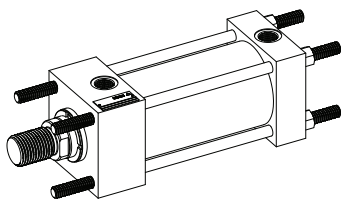
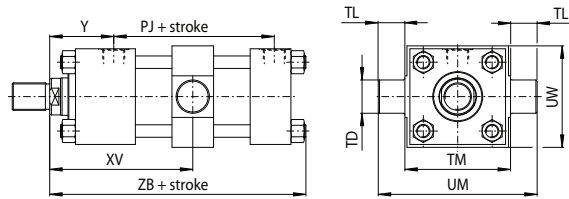

V (ISO MX2) = rear tie rods extended mounting
Y (ISO MX3) = front tie rods extended mounting
W (ISO MX1) = both end tie rods extended mounting (*)
 (*) see figure

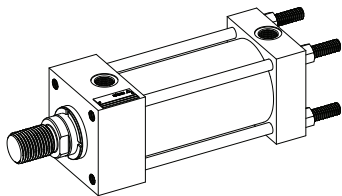
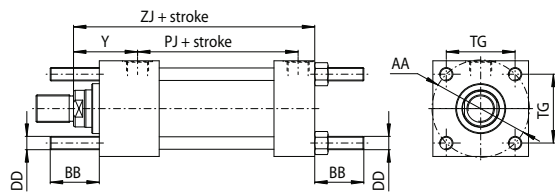

Z (ISO MX5) = front threaded holes mounting
T (ISO MX7) = threaded holes with tie rods extended mounting (*)
 (*) see figure

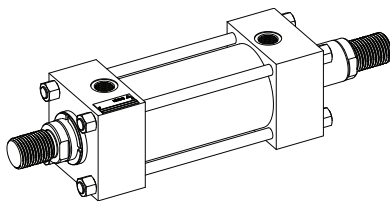
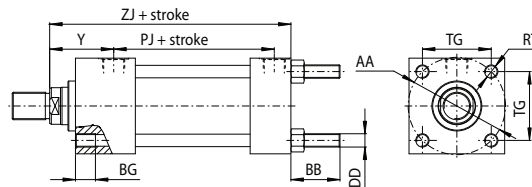

X = basic mounting for double rod

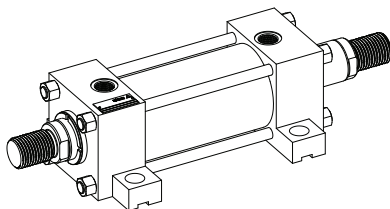
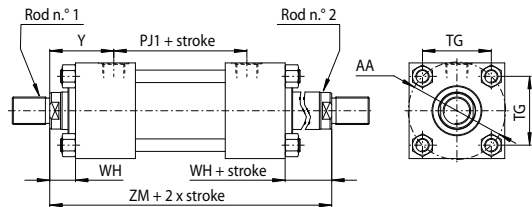

E = feet mounting for double rod

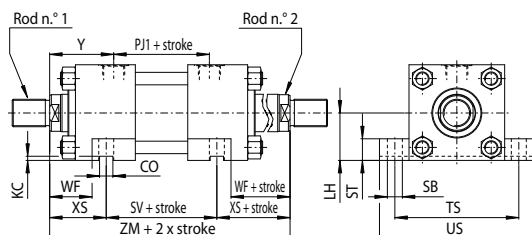

3 INSTALLATION DIMENSIONS [mm] - see figures in section **2**

Ø Bore		25	32	40	50	63	80	100	125	160	200
Ø Rod	standard	12	14	18	22	28	36	45	56	70	90
	intermediate	NA	NA	22	28	36	45	56	70	90	110
	differential	18	22	28	36	45	56	70	90	110	140
AA ref	40	47	59	74	91	117	137	178	219	269	
BB +3 / 0	19	24	35	46	46	59	59	81	92	115	
BG min	8	9	12	18	18	24	24	27	32	40	
CB A13	12	16	20	30	30	40	50	60	70	80	
CD H9	10	12	14	20	20	28	36	45	56	70	
CF max	25	34	42	62	62	83	103	123	143	163	
CO N9	NA	NA	12	12	16	16	16	20	30	40	
CX	value	12	16	20	25	30	40	50	60	80	100
	tolerance	0	-0,008	0				-0,012	0		-0,015
DD 6g	M5x0,8	M6x1	M8x1	M12x1,25	M12x1,25	M16x1,5	M16x1,5	M22x1,5	M27x2	M30x2	
E (1)	40±1,5	45±1,5	63±1,5	75±1,5	90±1,5	115±1,5	130±2	165±2	205±2	245±2	
EP max	8	11	13	17	19	23	30	38	47	57	
EW h14	12	16	20	30	30	40	50	60	70	80	
EX	10 0/-0,12	14 0/-0,12	16 0/-0,12	20 0/-0,12	22 0/-0,12	28 0/-0,12	35 0/-0,12	44 0/-0,15	55 0/-0,15	70 0/-0,2	
FA 0 / -0,075	8	8	8	14	14	NA	NA	NA	NA	NA	
FB H13	5,5	6,6	11	14	14	18	18	22	26	33	
H (2) max	5	5	NA	NA	NA	NA	NA	NA	NA	NA	
J ref	25	25	38	38	38	45	45	58	58	76	
L min	13	19	19	32	32	39	54	57	63	82	
LH h10	19	22	31	37	44	57	63	82	101	122	
LT min	16	20	25	31	38	48	58	72	92	116	
KC min	NA	NA	4	4,5	4,5	5	6	6	8	8	
M (3)	1000	1200	1500	1800	2300	3000	3500	3500	3500	3500	
MR max	12	17	17	29	29	34	50	53	59	78	
MS max	20	22,5	29	33	40	50	62	80	100	120	
PA 0 / -0,2	5	5	5	8	8	NA	NA	NA	NA	NA	
PJ (4) ±1,5 (6)	53	56	73	74	80	93	101	117	130	165	
PJ1 ±1,5 (6)	54	58	71	73	81	92	101	117	130	160	
PJ2 (4) ±1,5 (6)	53	57	73	76	80	93	99	121	143	167	
R js13	27	33	41	52	65	83	97	126	155	190	
RT	M5x0,8	M6x1	M8x1,25	M12x1,75	M12x1,75	M16x2	M16x2	M22x2,5	M27x3	M30x3,5	
SB H13	6,6	9	11	14	18	18	26	26	33	39	
SS ±1,25 (6)	72	72	97	91	85	104	101	130	129	171	
ST js13	8,5	12,5	12,5	19	26	26	32	32	38	44	
SV ±1,25 (6)	88	88	105	99	93	110	107	131	130	172	
TC h14	38	44	63	76	89	114	127	165	203	241	
TD f8	12	16	20	25	32	40	50	63	80	100	
TG js13	28,3	33,2	41,7	52,3	64,3	82,7	96,9	125,9	154,9	190,2	
TL js13	10	12	16	20	25	32	40	50	63	80	
TM h14	48	55	76	89	100	127	140	178	215	279	
TO js13	51	58	87	105	117	149	162	208	253	300	
TS js13	54	63	83	102	124	149	172	210	260	311	
UM ref	68	79	108	129	150	191	220	278	341	439	
UO max	65	70	110	130	145	180	200	250	300	360	
US max	72	84	103	127	161	186	216	254	318	381	
UT ref	58	68	95	116	139	178	207	265	329	401	
UW max	45	50	70	88	98	127	141	168	205	269	
XC ±1,5 (6)	127	147	172	191	200	229	257	289	308	381	
XG ±2 (6)	44	54	57	64	70	76	71	75	75	85	
XJ ±1,5 (6)	101	115	134	140	149	168	187	209	230	276	
XO ±1,5 (6)	130	148	178	190	206	238	261	304	337	415	
XS ±2 (6)	33	45	45	54	65	68	79	79	86	92	
XV (5) ±2 (6)	style L minimum stroke	5	5	5	15	20	20	35	35	35	
	min	77	90	100	109	120	129	148	155	161	
	max	75+stroke	86+stroke	99+stroke	98+stroke	100+stroke	115+stroke	117+stroke	134+stroke	141+stroke	166+stroke
Y (4) ±2 (6)	50	60	62	67	71	77	82	86	86	98	
Y1 (4) ±2 (6)	49,5	59,5	63	65,5	70	75,5	83	84	79,5	97	
ZB max	121	137	166	176	185	212	225	260	279	336	
ZJ ±1 (6)	114	128	153	159	168	190	203	232	245	299	
ZM ±2 (6)	154	178	195	207	223	246	265	289	302	356	

NOTES TO TABLE 3

- (1) **E** - If not otherwise specified in the figures in section **2**, this value is the front and rear square heads dimension for all the mounting styles (see figure below)
- (2) **H** - This additional dimension has to be considered only for bores 25 and 32

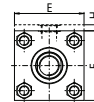

- (3) **M** - For strokes longer than M, one or more intermediate tie rods supports (1) are fitted on the cylinder housing to maintain the radial tension on the tie rods, thus keeping them rigidly fixed to the cylinder housing. The support has the same overall dimensions of the square heads as indicated in note (1)

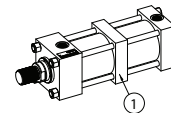

- (4) When oversized oil ports are selected (see section **11** and **13** for dimensions and position) dimensions **PJ** and **Y** are respectively modified into **PJ2** and **Y1**

- (5) **XV** - For cylinders with mounting style **L** the stroke must always exceed the minimum values reported in the table. The requested **XV** value must be included between **XV min** and **XV max** and it must be always indicated, with dimension in millimeters, together with the cylinder code. See the following example:

CK - 50 / 22 * 0500 - L301 - D - B1E3X1Z3
XV = 200

- (6) The tolerance is valid for strokes up to 1250 mm, for longer strokes the upper tolerance is given by the max stroke tolerance in section **4**

4 STROKE SELECTION

Stroke has to be selected a few mm longer than the working stroke, to prevent to use the cylinder heads as mechanical stroke-end.

Standard strokes to ISO 4393

25	50	80	100	125	160	200	250
320	400	500	630	800	1000	1250	

Maximum stroke:
 • 2600 mm for bores up to 40 mm
 • 5000 mm for other bores

Stroke tolerances:
 • 0 +2 mm for strokes up to 1250 mm
 • 0 +5 mm for strokes from 1250 to 3150 mm
 • 0 +8 mm for strokes over 3150 mm

5 SPACER

For strokes longer than 1000 mm, proper spacers have to be introduced in the cylinder's construction to increase the rod and piston guide and to protect them from overloads and premature wear. Spacers can be omitted for cylinders working in traction mode. The introduction of spacers increases the overall cylinder's dimensions: spacers' length has to be added to all stroke dependent dimensions in section **3**.

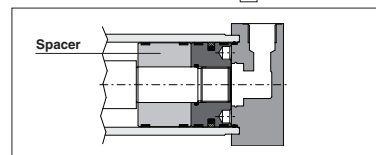

RECOMMENDED SPACERS [mm]

Stroke	1001 ÷ 1500	1501 ÷ 2000	2001 ÷ 2500	2501 ÷ 5000
Spacer code	2	4	6	8
Length	50	100	150	200

6 ROD END DIMENSIONS [mm]

Ø Bore	Ø Rod	Male thread		Female thread		A (KK or KF) (1)	A1 (KK1 or KF1) (1)	B	CH	F	RD	VD	VE	VL	WF	WH	WL
		KK 6g	KK1 (option H) 6g	KF (option F) 6H	KF1 (option G) 6H												
25	12	M10x1,25	NA	M8x1	NA	14	NA	24	10	10	38	6	16	3	25	15	5
	18	M14x1,5	M10x1,25	M12x1,25	M8x1	18	14	30	15	10	38	6	16	3	25	15	5
32	14	M12x1,25	NA	M10x1,25	NA	16	NA	26	12	10	42	12	22	3	35	25	5
	22	M16x1,5	M12x1,25	M16x1,5	M10x1,25	22	16	34	19	10	42	9	19	3	35	25	5
40	18	M14x1,5	NA	M12x1,25	NA	18	NA	30	15	10	62	6	16	3	35	25	5
	22(2)	M16x1,5	NA	M16x1,5	NA	22	NA	34	19	10	62	12	22	3	35	25	5
	28	M20x1,5	M14x1,5	M20x1,5	M12x1,25	28	18	42	22	10	62	12	22	3	35	25	7
50	22	M16x1,5	NA	M16x1,5	NA	22	NA	34	19	16	74	9	25	4	41	25	5
	28(2)	M20x1,5	NA	M20x1,5	NA	28	NA	42	22	16	74	9	25	4	41	25	7
	36	M27x2	M16x1,5	M27x2	M16x1,5	36	22	50	30	16	74	9	25	4	41	25	8
63	28	M20x1,5	NA	M20x1,5	NA	28	NA	42	22	16	75	13	29	4	48	32	7
	36(2)	M27x2	NA	M27x2	NA	36	NA	50	30	16	88	13	29	4	48	32	8
	45	M33x2	M20x1,5	M33x2	M20x1,5	45	28	60	39	16	88	13	29	4	48	32	10
80	36	M27x2	NA	M27x2	NA	36	NA	50	30	20	82	9	29	4	51	31	8
	45(2)	M33x2	NA	M33x2	NA	45	NA	60	39	20	105	9	29	4	51	31	10
	56	M42x2	M27x2	M42x2	M27x2	56	36	72	48	20	105	9	29	4	51	31	10
100	45	M33x2	NA	M33x2	NA	45	NA	60	39	22	92	10	32	5	57	35	10
	56(2)	M42x2	NA	M42x2	NA	56	NA	72	48	22	125	10	32	5	57	35	10
	70	M48x2	M33x2	M48x2	M33x2	63	45	88	62	22	125	10	32	5	57	35	10
125	56	M42x2	NA	M42x2	NA	56	NA	72	48	22	105	10	32	5	57	35	10
	70(2)	M48x2	NA	M48x2	NA	63	NA	88	62	22	150	7	29	5	57	35	10
	90	M64x3	M42x2	M64x3	M42x2	85	56	108	80	22	150	7	29	5	57	35	15
160	70	M48x2	NA	M48x2	NA	63	NA	88	62	25	125	7	32	5	57	32	10
	90(2)	M64x3	NA	M64x3	NA	85	NA	108	80	25	170	7	32	5	57	32	15
	110	M80x3	M48x2	M80x3	M48x2	95	63	133	100	25	170	7	32	5	57	32	15
200	90	M64x3	NA	M64x3	NA	85	NA	108	80	25	150	7	32	5	57	32	15
	110(2)	M80x3	NA	M80x3	NA	95	NA	133	100	25	210	7	32	5	57	32	15
	140	M100x3	M64x3	M100x3	M64x3	112	85	163	128	25	210	7	32	5	57	32	15

Notes: (1) Dimensions A and A1 are according to ISO 4395 short type.
Tolerances: max for male thread; min for female thread
(2) Not included in ISO standard

7 CYLINDER'S HOUSING FEATURES

The cylinder's housings are made in "cold drawn and stressed steel" with $R_s = 450 \text{ N/mm}^2$; the internal surfaces are lapped: diameter tolerance H8, roughness $R_a \leq 0,25 \mu\text{m}$.

8 TIE RODS FEATURES

The cylinder's tie rods are made in "normalized automatic steel" with $R_s = 610 \text{ N/mm}^2$; end-threads are rolled to improve the fatigue working life. They are screwed to the heads or mounted by means of nuts with a prefixed tightening torque MT, see the table at side.

9 RODS FEATURES and options

The rods materials have high strength, which provide safety coefficients higher than 4 in static stress conditions, at maximum working pressure. The rod surface is chrome plated: diameter tolerances f7; roughness $R_a \leq 0,25 \mu\text{m}$. Corrosion resistance of 200 h in neutral spray to ISO 9227 NSS

Ø Rod	Material	Rs min [N/mm ²]	Chrome	
			min thickness [mm]	hardness [HV]
12÷90	hardened and tempered alloy-steel	700	0,020	850-1150
110÷140	alloy steel	450		

Rod diameters from 12 to 70 mm have rolled threads; in rolling process the component material is stressed beyond its yield point, being deformed plastically. This offers many technical advantages: higher profile accuracy, improved fatigue working life and high wear resistance. See **tab. B015** for the calculation of the expected rod fatigue life. The rod and piston are mechanically coupled by a threaded connection in which the thread on the rod is at least equal to the external thread KK, indicated in the table [6]. The piston is screwed to the rod by a prefixed tightening torque in order to improve the fatigue resistance. The stop pin ① avoids the piston unscrewing. **Contact our technical office** in case of heavy duty applications.

Rod corrosion resistance and hardness can be improved selecting the options **K** and **T** (option K affects the strength of standard rod, see **tab. B015** for the calculation of the expected rod fatigue life):
K = Nickel and chrome-plating (for rods from 22 to 110 mm)
Corrosion resistance (rating 10 to ISO 10289):

- 350 h in acetic acid salt spray to ISO 9227 AASS
- 1000 h in neutral spray to ISO 9227 NSS

T = Induction surface hardening and chrome plating
• 56-60 HRC (613-697 HV) hardness

10 DOUBLE ROD

Double rod cylinders ensure the same pushing and pulling areas, thus the same speeds and forces. Rod2 (see figure at side) is screwed into the male thread of Rod1, consequently the Rod2 is weaker than the other and it is strongly recommended to use this one only to compensate the areas; the stronger rod is identified by the number '1' stamped on its end. For double rod cylinders, rod end dimensions indicated in section [6] are valid for both the rods.

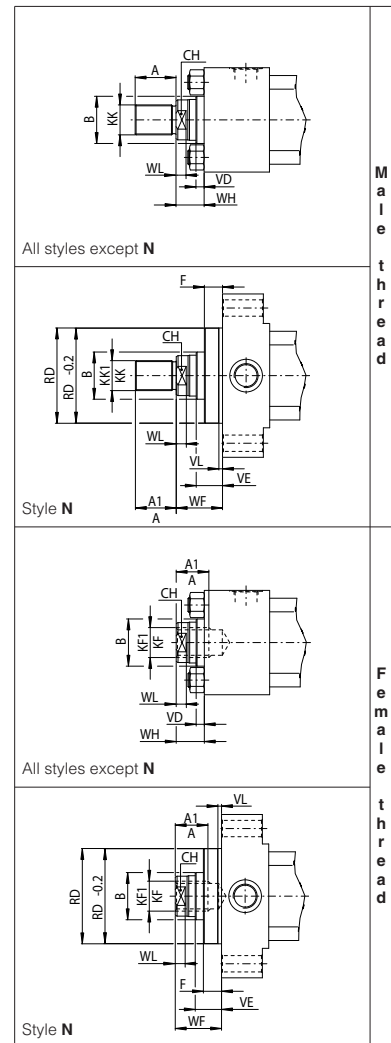

TIE RODS TIGHTENING TORQUES

Ø Bore	25	32	40	50	63
MT [Nm]	5	9	20	70	70
Wrench	8	10	13	19	19
Ø Bore	80	100	125	160	200
MT [Nm]	160	160	460	820	1160
Wrench	24	24	32	41	46

ROD-PISTON COUPLING

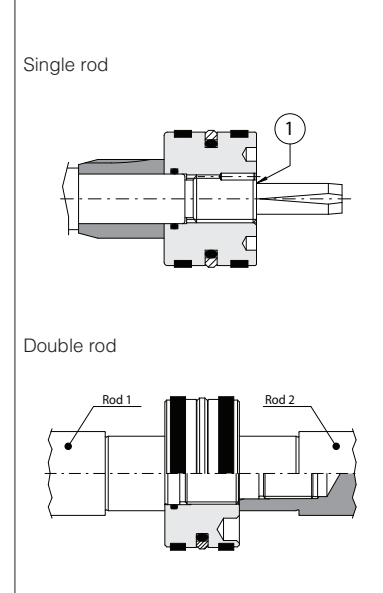

11 OIL PORTS AND ROD SPEEDS

The fluid speed in pipings connected to the cylinder oil ports should not exceed 6 m/s in order to minimize the turbulence flow, the pressure drop and water hammer. The table below shows the max recommended rod speed relative to 6 m/s flow velocity.

In high dynamic systems the rod can reach even higher speeds (after a careful check of dampable masses, see tab. B015): in these cases it is recommended to use piping's diameters larger than the cylinder oil ports and to introduce proper reductions just near the cylinder oil ports.

Ø Bore	Standard oil ports				Oversized oil ports D, Y options			
	D [mm]	EE 6g	Internal pipe Ø[mm] min	Rod speed V [m/s]	D [mm]	EE 6g	Internal pipe Ø[mm] min	Rod speed V [m/s]
25	21	G 1/4	7,5	0,54	25	G 3/8	9	0,77
32	21	G 1/4	7,5	0,33	25	G 3/8	9	0,47
40	25	G 3/8	9	0,30	29	G 1/2	14	0,73
50	29	G 1/2	14	0,47	36	G 3/4	16	0,61
63	29	G 1/2	14	0,30	36	G 3/4	16	0,39
80	36	G 3/4	16	0,18	42	G 1	20	0,37
100	36	G 3/4	16	0,15	42	G 1	20	0,24
125	42	G 1	20	0,15	52	G 1 1/4	30	0,34
160	42	G 1	20	0,09	52 (1)	G 1 1/4 (1)	30	0,21
200	52	G 1 1/4	30	0,13	58	G 1 1/2	40	0,24

12 CUSHIONINGS

Cushionings are recommended for applications where: • the piston makes a full stroke with speed over than 0,05 m/s; • it is necessary to reduce undesirable noise and mechanical shocks; • vertical application with heavy loads. The stroke-end cushionings are hydraulic dampers specifically designed to dissipate the energy of the mass connected to the cylinder rod, by progressively increasing the pressure in the cushioning chamber and thus reducing the rod speed before the cylinder's mechanical stroke-end (see the graphics at side). Two types of cushioning are available depending to the rod speed V:

Slow version for $V \leq 0,5 \cdot V_{max}$

Fast version for $V > 0,5 \cdot V_{max}$

See the table below for V_{max} values and tab. B015 for the max damping energy.

When fast or slow adjustable versions are selected, the cylinder is provided with needle valve to optimize cushioning performances in different applications. The regulating screws are supplied fully screwed in (max cushioning effect).

In case of high masses and/or very high operating speeds it is recommended to back them off to optimize the cushioning effect. The adjustment screw has a special design to prevent unloading and expulsion. The cushioning effect is highly ensured even in case of variation of the fluid viscosity.

Ø Bore	25	32	40	50	63	80	100	125	160	200
Ø Rod	12 18 14 22	18 22 28 22	22 28 28 28	28 36 45 36	36 45 56 45	45 56 70 56	56 70 90 70	70 90 110 90	90 110 140 110	110
Cushioning length [mm]	Lf front	21 17 23 17	26 25 28 27	28 27 28 27	27 29 35 27	28 25 34 34	49 34			
	Lf rear	13	15	27	28	30	32	32	41	56
V_{max} [m/s]	1	1	1	1	0,8	0,8	0,6	0,6	0,5	0,5

13 POSITION COMBINATION FOR OIL PORTS AND CUSHIONING ADJUSTMENTS

FRONT HEAD: **B*** = oil port position; **E*** = cushioning adjustment position REAR HEAD: **X*** = oil port position; **Z*** = cushioning adjustment position
The table below shows all the available configurations for the oil port and cushioning adjustment positions. Bolt characters identify the standard positions. Each configuration for the front head can be variously combined with any one of the rear head. Cushioning adjustment positions **E***, **Z*** have to be entered only if adjustable cushionings are selected.

Example of model code: CK-50/22 *0100-S301 - A - B2E3X1Z4

Mounting style	C, D, S, L										E, K		G	H			N, P			T, V, W, X, Y, Z					
	B	1	1	2	1	2	4	3	1	1	1	1	2	1	1	2	1	1	2	3	1	1	2	3	
FRONT HEAD	Oil port side	B	1	1	2	1	2	4	3	1	1	1	1	2	1	1	2	1	1	2	3	1	1	2	3
	Cushioning adjustment side	E	3	2	3	4	4	3	1	2	4	3	3	4	3	2	3	3	4	3	1				
REAR HEAD	Oil port side	X	1	1	2	1	2	4	3	1	1	1	2	1	1	1	2	1	1	2	3	1	1	2	3
	Cushioning adjustment side	Z	3	2	3	4	4	3	1	2	4	3	4	3	3	2	3	3	4	3	1				

• Not available for bores 25 and 32. Dimensions **PJ**, **PJ2**, **Y** and **Y1** change compared to the values in section 3, contact our technical office

(a) Front view rod side (rod n°1 for double rods)

Contact our technical office for combinations not included in the table.

14 SEALING SYSTEM FEATURES

The sealing system must be chosen according to the working conditions of the system: speed, operating frequencies, fluid type and temperature. Additional verifications about minimum in/out rod speed ratio, static and dynamic sealing friction are warmly suggested, see tab. B015.

When single acting seals are selected (types 6 and 7), the not pressurized cylinder's chamber must be connected to the tank. Special sealing system for low temperatures, high frequencies (up to 20 Hz), long working life and heavy duty are available, see tab. TB020. All the seals, static and dynamic, must be periodically replaced: proper spare kits are available, see section 22. Contact our technical office for the compatibility with other fluids not mentioned below and specify type and composition. See section 19 for fluid requirements.

Sealing system	Material	Features	Max speed [m/s]	Fluid temperature range	Fluids compatibility	ISO Standards for seals	
						Piston	Rod
1	NBR + POLYURETHANE	high static and dynamic sealing	0,5	-20°C to 85°C	Mineral oils HH, HL, HLP, HLP-D, HM, HV, MIL-H-5606	ISO 7425/1	ISO 5597/1
2	FKM + PTFE	very low friction and high temperatures	4	-20°C to 120°C	Mineral oils HH, HL, HLP, HLP-D, HM, HV, MIL-H-5606 fire resistance fluids HFA, HFB, HFC (water max 45%), HFD-U, HFD-R	ISO 7425/1	ISO 7425/2
4	NBR + PTFE	very low friction and high speeds	4	-20°C to 85°C	Mineral oils HH, HL, HLP, HLP-D, HM, HV, MIL-H-5606 fire resistance fluids HFA, HFC (water max 45%), HFD-U	ISO 7425/1	ISO 7425/2
6 - 7	NBR + PTFE	very low friction single acting - pushing/pulling	1	-20°C to 85°C	Mineral oils HH, HL, HLP, HLP-D, HM, HV, MIL-H-5606 fire resistance fluids HFA, HFC (water max 45%), HFD-U	ISO 7425/1	ISO 7425/2
8	PTFE + NBR + POLYURETHANE	low friction	0,5	-20°C to 85°C	Mineral oils HH, HL, HLP, HLP-D, HM, HV, MIL-H-5606	ISO 7425/1	ISO 7425/2

Oil ports features are threaded according to ISO 1179-1 (GAS standards) with counter-bore dimension D type N (narrow).

Oil ports with SAE 3000 flanges are available on request, contact our technical office.

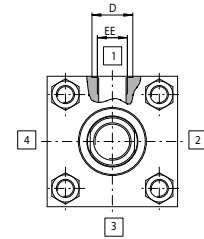

Note to table:

(1) For mounting styles C, D, E, N, P, S the dimension **PJ2** reported in section 3 is modified, contact our technical office.

Lf is the total cushioning length. When the stroke-end cushionings are used as safety devices, to mechanically preserve the cylinder and the system, it is advisable to select the cylinder's stroke longer than the operating one by an amount equal to the cushioning length Lf; in this way the cushioning effect does not influence the movement during the operating stroke.

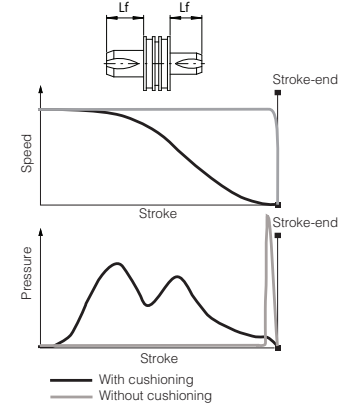

15 INCORPORATED SUBPLATE

CK cylinders can be supplied with ISO (size 06, 10, 16 and 25) incorporated subplates for mounting of valves directly on the cylinder.

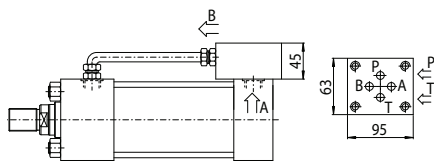

10 = subplate with mounting surface 4401-03-02-0-05 (size 06)
Oil ports P and T = G 3/8
For bores from 40 to 200 and strokes longer than 100 mm
For shorter strokes, the cylinder must be provided with suitable spacer

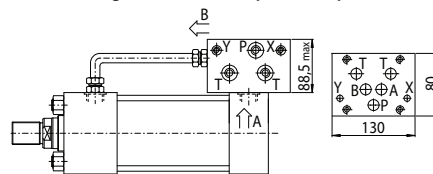

20 = subplate with mounting surface 4401-05-05-0-05 (size 10)
Oil ports P and T = G 3/4; X and Y = G 1/4
For bores from 40 to 200 and strokes longer than 150 mm
For shorter strokes, the cylinder must be provided with suitable spacer

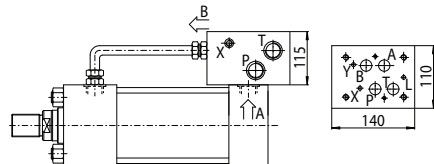

30 = subplate with mounting surface 4401-07-07-0-05 (size 16)
Oil ports P and T = G 1; L, X and Y = G 1/4
For bores from 80 to 200 and strokes longer than 150 mm
For shorter strokes, the cylinder must be provided with suitable spacer

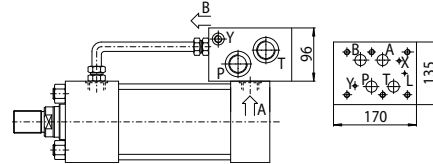

40 = subplate with mounting surface 4401-08-08-0-05 (size 25)
Oil ports P and T = G 1; L, X and Y = G 1/4
For bores from 125 to 200 and strokes longer than 150 mm
For shorter strokes, the cylinder must be provided with suitable spacer

Note: for the choice of suitable spacer see section 5. The addition of spacer length and working stroke must be at least equal or upper than the minimum stroke indicated above, see the following example:
Subplate **20**; working stroke = **70** mm; min. stroke = **150** mm → select spacer **4** (length = **100**mm)

16 AIR BLEEDS

CODES: **A** = front air bleed; **W** = rear air bleed

The air in the hydraulic circuit must be removed to avoid noise, vibrations and irregular cylinder's motion: air bleed valves are recommended to realize this operation easily and safely. Air bleeds are usually positioned on the opposite side of the oil port except for front heads of mounting styles **N, G** (on side 3), rear heads of mounting styles **C, D, S, H, P** (on side 3) and for heads of mounting style **E** (on side 2), see section 13. For cylinders with adjustable cushionings the air bleeds are positioned on the same side of the cushioning adjustment screw. For Servocylinders, cylinders with incorporated subplates or proximity sensors, air bleeds are supplied as standard and they must not be entered in the model code. For cylinders with proximity sensors, air bleeds A, W or AW are supplied respectively depending on the selected sensors R, S or RS. For a proper use of the air-bleed (see figure on side) unlock the grub screw ① with a wrench for hexagonal head screws, bleed-off the air and retighten as indicated in table at side.

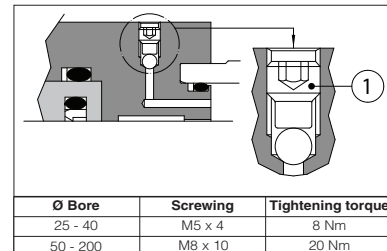

17 DRAINING

CODE: **L** = rod side draining

The rod side draining reduces the seals friction and increases their reliability; it is mandatory for cylinders with strokes longer than 2000 mm, with rod side chamber constantly pressurized and for servocylinders. The draining is positioned on the same side of the oil port, between the wiper and the rod seals (see figure at side) and it can be supplied only with sealing system: **1, 2, 4, 7** and **8**. It is recommended to connect the draining port to the tank without backpressure. Draining port is G1/8.

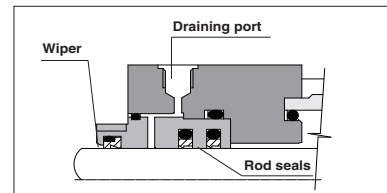

18 PROXIMITY SENSORS

CODES: **R** = front sensor; **S** = rear sensor

Proximity sensors functioning is based on the variation of the magnetic field, generated by the sensor itself, when the cushioning piston enters on its influence area, causing a change of state (on/off) of the sensors. The distance from the mechanical stroke-end of the cylinder, at which occurs the switching of the sensor's electrical contact, can be adjusted between 1 and 3 mm. For their regulation, it is necessary to position the rod where it is desired to obtain the contact switching and rotate the sensor until its LED switch-on (commutation occurred). The sensors tightening torque must be lower than 40 N/m to avoid damages. The sensors must always be coupled with fast adjustable cushioning, see section 12, to avoid pressure peaks on stroke-end. They are positioned on side 4 and they can be coupled with the standard oil ports and cushioning adjustments positions in bolt characters, see section 13. The coupling of the proximity sensors with the stroke-end cushioning imposes particular executions with limitation of the damping masses and/or speeds compared to the executions with standard cushioning.

Limitations

R, S options not available for cylinders with bores smaller than 40 mm.

R option not available for G and N mounting styles; **S** option not available for P and H mounting styles.

Ø Bore	40	50	63	80	100	125	160	200
DB max	77	75	72	74	73	71	71	67
DC	67	71	65	71	65	51	34	20

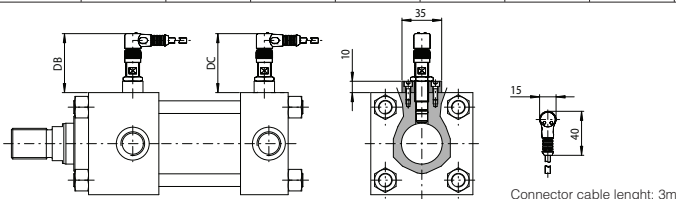

SENSORS TECHNICAL DATA

The proximity sensors are inductive type, they supply a "NO" (Normally Open) output signal which status corresponds to the rod position:

- **R, S** = close contact = 24 Volt at output contacts = rod positioned at stroke ends
- **R, S** = open contact = 0 Volt at output contacts = rod not positioned at stroke ends

Ambient temperature	-20 +70°C
Nominal voltage	24 VDC
Operating voltage	10...30 VDC
Max load	200 mA
Version	PNP
Output type	NO
Repeatability	<5%
Hysteresis	<15%
Protection	IP68
Max pressure	25 MPa (250 bar)

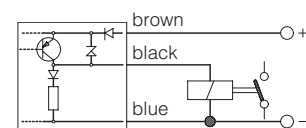

19 FLUID REQUIREMENTS

Cylinders and servocylinders are suitable for operation with mineral oils with or without additives (**HH, HL, HLP, HLP-D, HM, HV**), fire resistant fluids (**HFA** oil in water emulsion - 90-95% water and 5-10% oil, **HFB** water in oil emulsion - 40% water, **HFC** water glycol - max 45% water) and synthetic fluids (**HFD-U** organic esters, **HFD-R** phosphate esters). The fluid must have a viscosity within 15 and 100 mm²/s, a temperature within 0 and 70°C and fluid contamination class ISO 19/16 according to ISO 4406, achieved with in-line filters at 25 µm.

20 CYLINDERS MASSES [kg] (tolerance ± 5%)

Ø Bore [mm]	Ø Rod [mm]	MASS FOR STYLES X, Z Single rod		MASS FOR STYLES X, Z Double rod		ADDITIONAL MASSES according to mounting styles and options												
		Stroke 100 mm	Each added 100 mm	Stroke 100 mm	Each added 100 mm	Style C	Style D	Style E	Style G	Style K	Style L	Style N	Style P	Style S	Styles V Y	Style W	Each cushioning	Each 50 mm spacer
25	12	1,65	0,47	1,95	0,56	0,08	0,068	0,22	- 0,02	0,1	0,19	0,18	0,18	0,08	0,01	0,02	0,03	0,38
	18	1,80	0,58	2,40	0,78													
32	14	2,23	0,49	2,69	0,61	0,17	0,15	0,24	0,02	0,16	0,29	0,18	0,18	0,14	0,02	0,04	0,04	0,50
	22	2,51	0,67	3,21	0,97													
40	18	4,90	0,79	6,78	0,99	0,27	0,22	0,256	0,08	0,2	0,78	0,76	0,76	0,57	0,06	0,12	0,07	0,79
	22	5,15	0,89	7,19	1,19													
	28	5,40	1,07	7,60	1,55													
50	22	6,40	1,18	7,85	1,48	0,84	0,74	0,52	0,28	0,39	1,46	1,1	1,1	0,31	0,16	0,32	0,13	1,15
	28	6,59	1,37	8,23	1,85													
	36	7,20	1,68	9,45	2,48													
63	28	8,70	1,62	11,08	2,10	0,52	0,41	1,54	0,26	1,25	2,17	1,34	1,34	0,46	0,16	0,32	0,25	1,68
	36	9,13	1,93	11,94	2,73													
	45	9,80	2,39	13,64	3,64													
80	36	17,00	2,96	20,45	3,76	1,25	0,79	1,23	1,63	NA	3,67	2,39	2,39	0,86	0,34	0,68	0,40	2,85
	45	17,76	3,46	21,97	4,71													
	56	18,10	4,09	23,90	6,02													
100	45	23,80	3,90	29,85	5,15	3,05	2,31	1,63	1,00	NA	5,46	2,94	2,94	1,77	0,34	0,68	0,60	4,15
	56	24,70	4,6	32,01	6,53													
	70	26,00	5,68	35,20	8,70													
125	56	43,60	6,15	53,60	8,08	3,95	2,87	4,60	1,50	NA	8,60	5,65	5,65	4,65	0,90	1,80	1,15	6,61
	70	45,24	7,25	58,55	10,27													
	90	49,62	9,21	72,88	14,20													
160	70	74,55	8,75	85,96	11,77	8,33	7,63	7,56	4,66	NA	16,58	7,97	7,97	8,21	1,50	3,00	1,85	10,75
	90	79,31	10,72	96,08	15,71													
	110	83,90	13,18	106,20	20,64													
200	90	123,60	12,50	136,52	17,49	10,00	13,82	14,60	9,86	NA	37,00	16,78	16,82	14,80	2,50	5,00	2,50	15,86
	110	130,39	14,52	142,65	21,98													
	140	137,19	19,14	148,78	31,22													

Note: the masses related to the other options, not indicated in the table, don't have a relevant influence on the cylinder's mass

21 CYLINDER SECTION

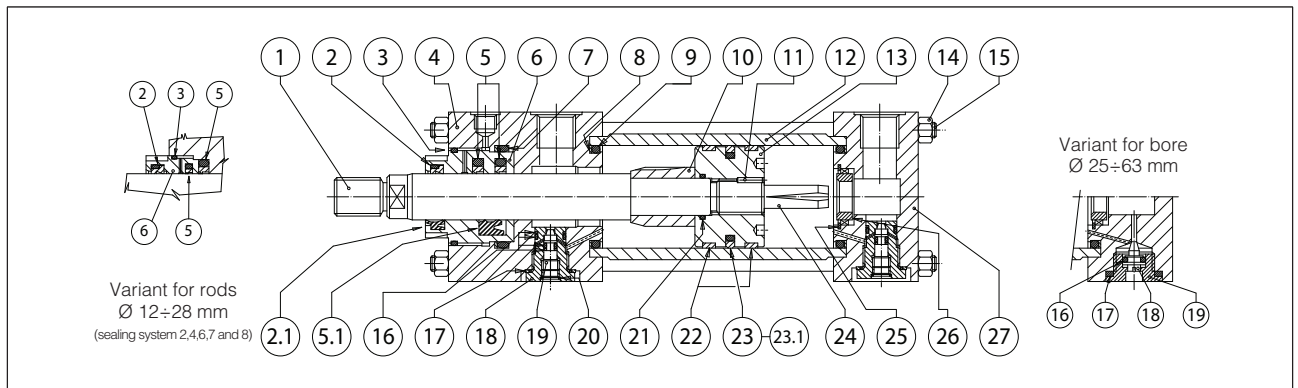

POS.	DESCRIPTION	MATERIAL	POS.	DESCRIPTION	MATERIAL	POS.	DESCRIPTION	MATERIAL
1	Rod	Chrome plated steel	9	O-ring	NBR / FKM	19	Cushioning adjustment screw	Steel
2	Wiper	NBR / FKM and PTFE	10	Front cushioning piston	Steel	20	Seeger	Steel
2.1	Wiper (G1)	Polyurethane	11	Screw stop pin	Steel	21	O-ring	NBR / FKM
3	O-ring	NBR / FKM	12	Cylinder housing	Steel	22	Piston guide ring	PTFE or phenolic resin
4	Front head	Steel / cast iron	13	Piston	Steel	23	Piston seal	NBR / FKM and PTFE
5	Rod seal	NBR / FKM and PTFE	14	Nut	Steel	23.1	Piston seal (G1)	NBR and Polyurethane
5.1	Rod seal (type G1)	Polyurethane	15	Tie rod	Steel	24	Rear cushioning piston	Steel
6	Rod bearing	Bronze	16	O-ring and anti-extrusion ring	FKM and PTFE	25	Toroidal ring	Steel
7	O-ring and anti-extrusion ring	NBR / FKM and PTFE	17	Bonded seal	Steel and NBR	26	Rear cushioning sleeve	Bronze
8	Anti-extrusion ring	PTFE	18	Cushioning adjustment plug	Steel	27	Rear head	Steel / cast iron

22 SPARE PARTS - SEE TABLE SP-B137

Example for seals spare parts code

G 8 - C K - 50 / 22 / 22 - 32

Sealing system								Serial number
Cylinder series								Second rod diameter for double rod [mm] Omit if not requested
Bore size [mm]								Rod diameter [mm]