

HAND PUMPS

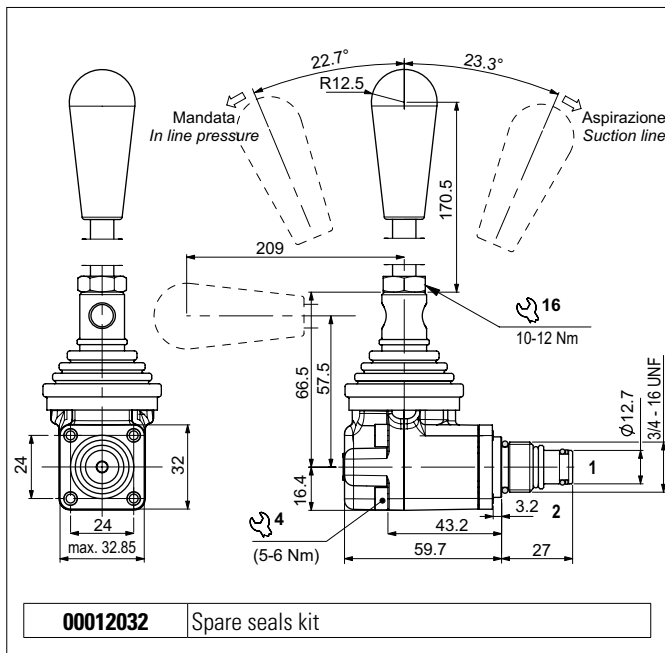

This hand pump handles emergencies manually in small systems. Available in 1cc/pump stroke and 2cc/pump stroke displacement versions. The lever body is in diecast aluminium. The cartridge is steel with tempered and ground steel ball check valves.

HYDRAULIC FEATURES

Max. working pressure	CPM041 = 300 bar CPM042 = 160 bar
Displacement	CPM041 = 1 cc stroke CPM042 = 2 cc stroke
Working Temperature	-25°C ÷ 60°C
Max. Leakage (0 ÷ 5 drops/min)	0 ÷ 0.25 cm ³ /min
Hydraulic fluid	DIN 51524 Mineral oils
Fluid viscosity	10 ÷ 500 mm ² /s
Fluid temperature	-25°C ÷ 75°C
Max. contamin. level class with filter	ISO 4406:1999 - class 19/17/14
Weight	0.41 kg
Tightening torque	25 ÷ 30 Nm
Cavity (3/4 - 16 UNF)	CD018006 (See section 15)

HYDRAULIC SYMBOL

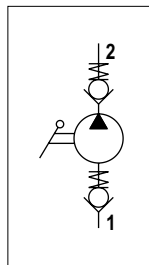

OPERATION FORCE ON THE LEVER

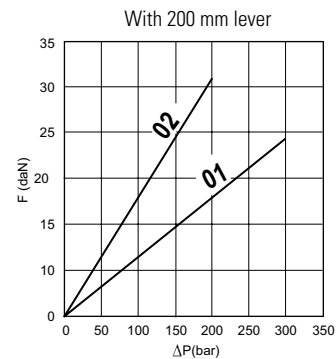

Fluid used: mineral based oil with viscosity 32 mm²/s at 40°C.

ORDERING CODE

