

# Analog electronic E-BM-AC drivers

DIN 43700 UNDECAL fast plug-in, for proportional valves without transducer

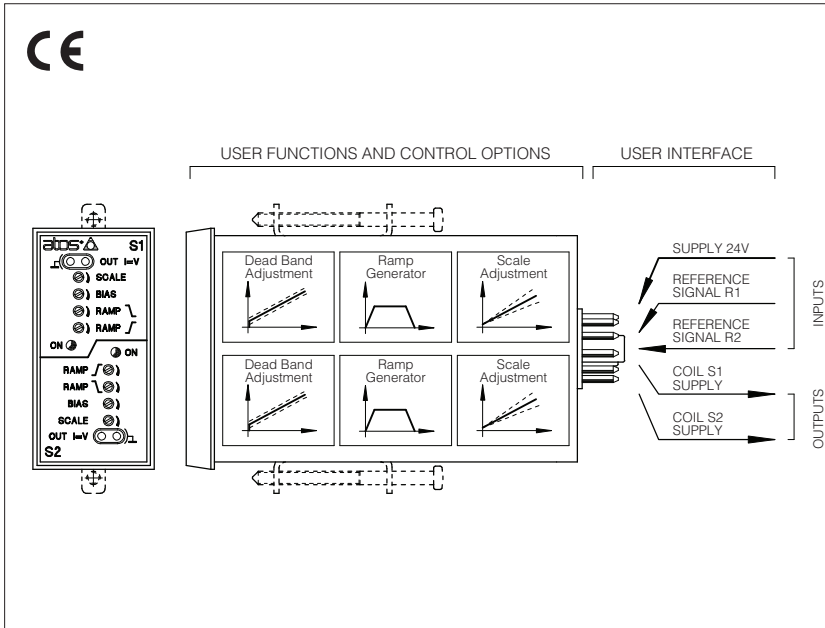

## E-BM-AC

Analog drivers control the current to the solenoid of Atos proportional valves without pressure or position transducer, regulating the spool position, the flow or the pressure according to the electronic reference signal.

### Features:

- bias and scale regulations by potentiometers
- symmetrical (standard) or dissymmetrical (/RR option) rising and falling ramp generator
- factory pre-set
- aluminium box (DIN 43700 modular unit)
- can be mounted on back panel DIN guide or on front panel
- power supply 24 VDC or 12 VDC (/12 option)
- electronic filters on input and output lines
- CE marking according to EMC directive

### Applications:

Pressure, flow, position open or closed-loop regulation systems, according to the block diagram [2].

## 1 MODEL CODE

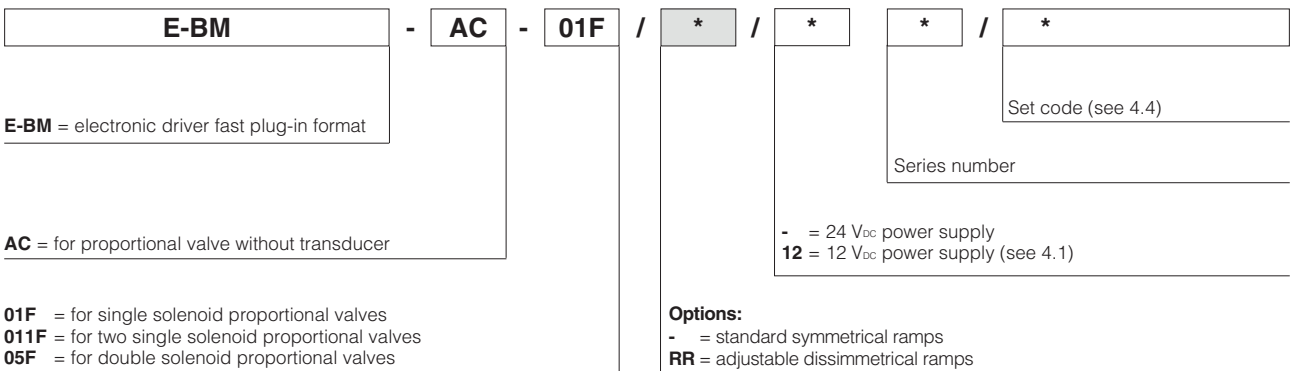

## 2 BLOCK DIAGRAM

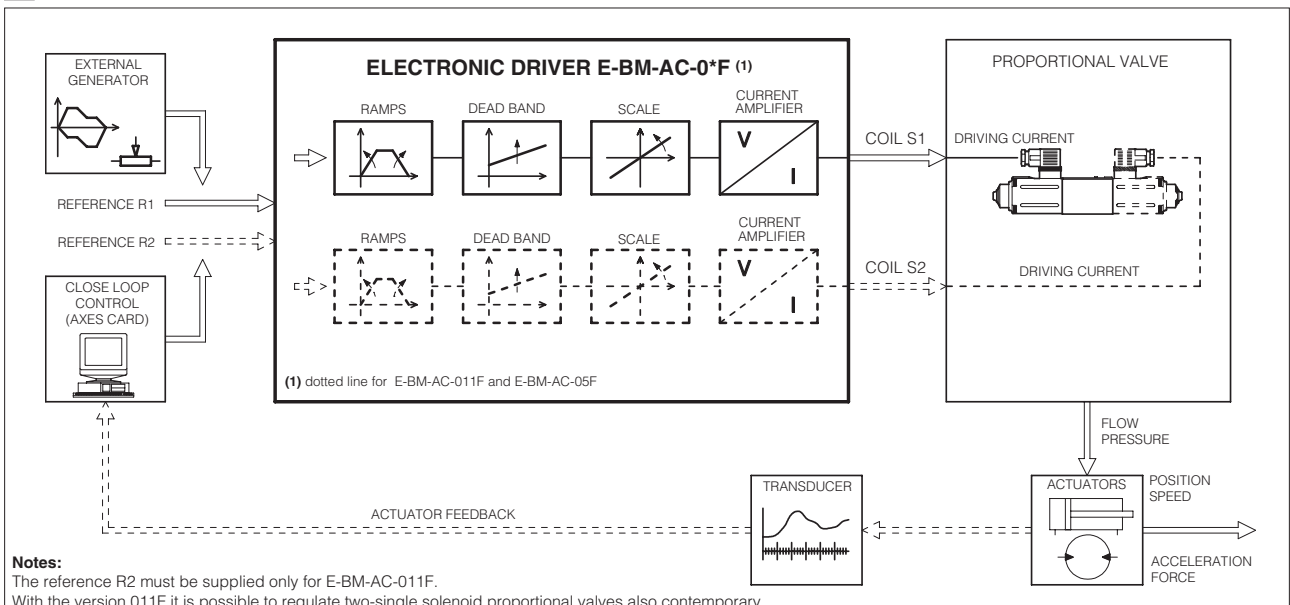

### 3 MAIN CHARACTERISTICS

Power supply (positive on contact 11, negative on contact 1)	Nominal : +24 V <sub>DC</sub> or +12 V <sub>DC</sub> (see 4.1) Rectified and filtered : V <sub>RMS</sub> = 21 ÷ 33 V <sub>MAX</sub> (ripple max peak to peak = ±20 %)
Max. power consumption	40 W
Current supplied to solenoids	I <sub>MAX</sub> = 3,3 A type PWM square wave (with solenoid type ZO(R)-A with resistance 3,2 Ω) I <sub>MAX</sub> = 2,5 A type PWM square wave (with explosion-proof solenoid with resistance 3,2 Ω)
Nominal reference signal, factory pre-set	E-BM-AC-01F R1 0 ÷ +5 V at contact 3 (GND on 2) E-BM-AC-11F R1, R2 0 ÷ +5 V at contact 3 (GND on 2) and 0 ÷ +5 V at contact 8 (GND on 7) E-BM-AC-05F R1 ± 5 V at contact 3 (GND on 2)
Reference signal variation range (Scale adjustment)	± 10 V <sub>MAX</sub> ± 2,5 V <sub>MIN</sub>
Input signal impedance	Voltage signal R <sub>i</sub> > 10 KΩ
External potentiometers supply	+5 V / 10 mA at contact 6 (-5 V / 10 mA at contact 7 only for version E-BM-AC-05F)
Ramp time	10 sec. max (0 ÷ 100 % of reference signal)
Electrical wiring	Coils : 2 x 1 mm <sup>2</sup> cable up to 20 m; 2 x 1,5 mm <sup>2</sup> shielded cable to 40 m
Box format	Aluminium box DIN 43700
Connector elements available	UNDECAL socket for guide DIN EN 50022-50035 type E-K-11B mounting <b>To be ordered separately</b>
Operating temperature	-10 ÷ +60 °C (storage -20 ÷ +70 °C)
Dimensions	32 x 72 x 127 mm
Mass	270 g
Features	Rapid solenoid excitation and switching off Outputs to solenoids protected against accidental short circuits

### 4 GENERAL SPECIFICATIONS

#### 4.1 Power supply and wiring

The power supply must be appropriately stabilized or rectified and filtered. If the power supply is generated by a single phase rectifier use a 10000 µF/40V capacitor; if pulse voltage is generated by a three phase rectifier, connect a 4700 µF/40V capacitor (see [13]).

Connect the reference signal to the main electronic control by means of shielded and twisted cables. Pay attention: the negative and the positive poles must not be exchanged each other.

Shield the wirings to avoid electromagnetic noise (EMC).

It is suitable to keep the driver and its cables far from any electromagnetic radiation source (like cables where high currents flow, electric motors, transformers, relays, solenoids, portable radio-transmitter, etc.). Wire the earth connection as shown in [13], according to CEI EN 60204-1 standards. Connect the shield of the driver to the noiseless earth terminal (TE) [16].

The driver is designed to correctly work with 24 V<sub>DC</sub> (±20%) or 12 V<sub>DC</sub> (±20%) nominal voltage supply coupled with coils having a resistance from 2,1 Ω to 3,2 Ω, as shown in the side table.

Nominal supply	Valve code	R at 20 °C [Ω]
24 V <sub>DC</sub>	*ZMO, *ZGO, *ZO(R)-A* (1)	3,2
12 V <sub>DC</sub>	*ZMA, *ZGA, *ZO(R)-A* (1)	3,2
	*ZMO, *ZGO, *ZO(R)-A*/6	2,1

(1) Standard coupling

#### 4.2 Reference signal

The electronic driver is designed to receive a voltage reference signal according to the following options:

- potentiometers mounted externally and wired according to the application diagrams, see [5].
- external reference signals generated by PLC, see [14] and [15].

#### 4.3 Monitor signal

This voltage output signal allows to measure the current supplied to the coil, read by a voltmeter on the front panel test points (see [9]). Reading scale is 1 mV = 1 mA.

To visualize the signals use voltmeters with impedance >10 KΩ.

#### 4.4 Set code

Basic calibration of the electronic driver is factory pre-set, according to the proportional valve it has to be coupled with. These pre-calibrations are identified by a standard number in the model code as follows:

1 = RZGO, KZGO                      3 = DHZO, DKZOR                      4 = DPZO-A-\*5, DPZO-A-\*7  
2 = RZMO, AG\*ZO, LI\*ZO            3B = DHZO-A-06, DKZOR-A-16        4B = DPZO-A-\*6  
6 = QV\*ZO(R), LIQZO

For ex-proof valves, insert an "A" before the code of adjustment.

For example, the code of adjustment for RZGA is A1 (see tech table F600).

The calibrations 3B and 4B allow the coupling with single solenoid valves with two external positions.

#### 4.5 Calibrations available to the user, see [7], [9], [10], [11].

##### Scale

The relation between driving current and reference signal can be regulated with the Scale adjustment.

For single solenoid valves with two external operating positions, the reference signal is ± 5V (calibration codes 3B and 4B).

Separate Scale potentiometers P3 and P4 for solenoids S1 and S2 enable the electronic card to be set for different output currents, obtaining differential hydraulic operations.

##### Bias (dead band)

Regulation of dead band adjusts the hydraulic zero of the valve (starting position adjustment) to a minimum signal of 200 mV. The electronic card is factory pre-set for the valve it is coupled with, according to the set code (see section 4.4). E-BM-AC-05F/\* driver for double solenoid are equipped with an internal channel selector enabling the relevant channel with input reference voltage signal greater than ± 200 mV and supplying the bias current set by front panel Bias potentiometers P1 and P2 for each solenoid.

E-BM-AC-01F/\* and E-BM-AC-011F/\* drivers for single solenoids are equipped with an internal channel selector enabling the relevant channel with input reference voltage signal greater than + 200 mV and supplying the bias current set by front panel Bias potentiometers P1 and P2 for each solenoid (P2 available only for E-BM-AC-011F/\* drivers).

For drivers type E-BM-AC-01F with calibration codes 3B and 4B there is not threshold and the bias is used for the adjustment of the central position of the valve.

### 5 EXTERNAL REFERENCE SIGNALS

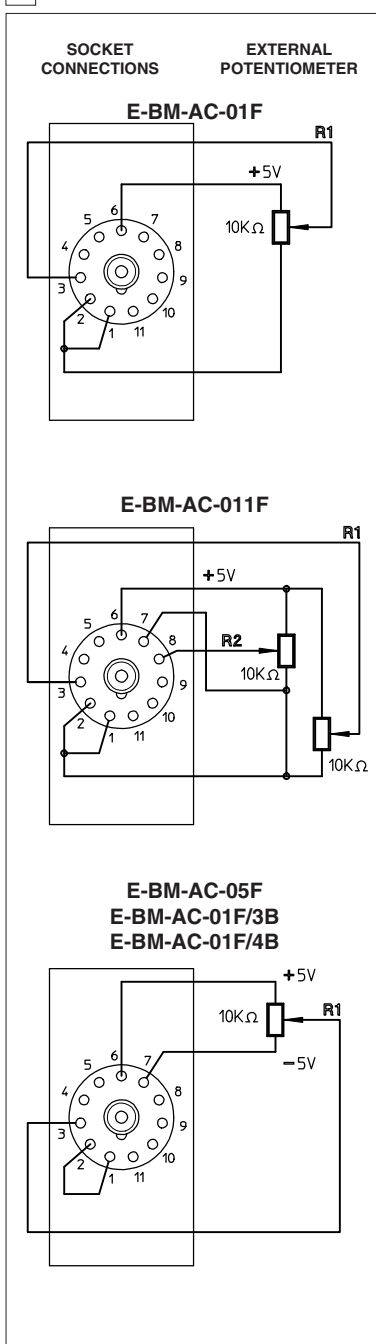

Ramps see [7], [9].

The internal ramp generator circuit converts a step input signal into a slowly increasing output signal (solenoid current). The rise/fall time of the current is set via potentiometers on front panel up to a max. time of 10 sec. for 0-100% of reference signal.

The /RR option allows up and down dissymmetrical ramps for each solenoid.

## 6 INSTALLATION AND START-UP

It is advisable to perform calibration procedures in the order given below.

### 6.1 Warning

- Never insert or remove the driver while the electronic system is powered on.
  - Protect the regulator on power line with an external fuse (2,5A RTV for version E-BM-AC-01F and E-BM-AC-05F; 5A RTV for E-BM-AC-011F)
  - Refer to section [9] to identify components mentioned in calibration procedures.
  - It is possible to install the E-BM-AC driver on front panel (drilling plane 33,5x68,5 mm) or on back panel DIN guide (see fig. [8]).
- The electrical connection is made on the clamps of the proper UNDECAL type E-K-11B socket, equipped with antivibrating spring.

### 6.2 Start-up

Factory pre-set adjustments might not meet the requirements desired for the specific application. Performances can be optimized by on-site re-adjustments of Bias, Scale and ramps potentiometers, in sequence.

- Connect the electronic driver according to the desired connection diagram, (see [5], [14], [15]).
- The current supplied to the coil can be measured by a voltmeter connected between the test points on the front panel.

The reading range will be:  $I[\text{mA}] = V[\text{mV}]$ .

**Bias adjustment** (dead band compensation), see [9], [10], [11].

For E-BM-AC-01F and E-BM-AC-11F:

- supply a reference signal voltage  $R1 = +0,2 V_{\text{DC}}$ ;
- turn clockwise the potentiometer P1 for solenoid S1 until the movement of the controlled actuator is obtained.
- turn the potentiometer P1 in the opposite direction until the actuator is stopped.
- for version E-BM-AC-011F repeat the operation and supply a reference signal voltage  $R2 = +0,2 V_{\text{DC}}$  by the potentiometer P2.

For E-BM-AC-05F:

- supply a reference voltage  $R1 = +0,2 V_{\text{DC}}$ ;
- turn clockwise the potentiometer P1 for solenoid S1 until the movement of the controlled actuator is obtained.
- turn the potentiometer P1 in the opposite direction until the actuator is stopped.
- repeat the operation and supply a reference signal voltage  $R1 = -0,2 V_{\text{DC}}$  by the potentiometer P2.

**Scale adjustment** (see [9], [10], [11])

Supply max. reference signal voltage R1 (for E-BM-AC-05F driver repeat for max. negative reference voltage signal R1) in the specified range and turn scale potentiometer P3 (P4 for negative reference signal) until the actuator speed reaches the desired value.

For version E-BM-AC-011F repeat the operation and supply the max positive reference signal R2 by the potentiometer P4.

**Ramps**, see [7], [9].

Turning the ramp potentiometer(s) clockwise, acceleration(s) and deceleration(s) can be reduced to obtain the optimization of the complete system.

## 7 RAMPS

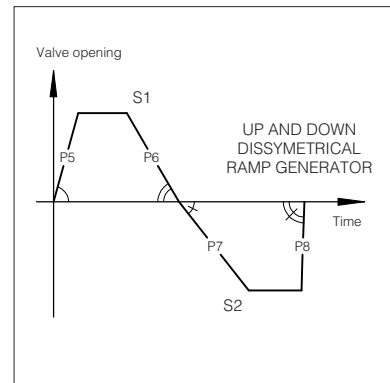

## 8 DIMENSIONS (mm)

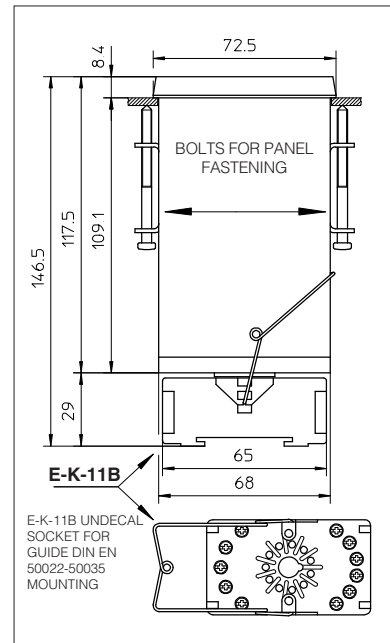

## 9 E-BM-AC-05F TOPOGRAPHICAL VIEW OF REGULATIONS

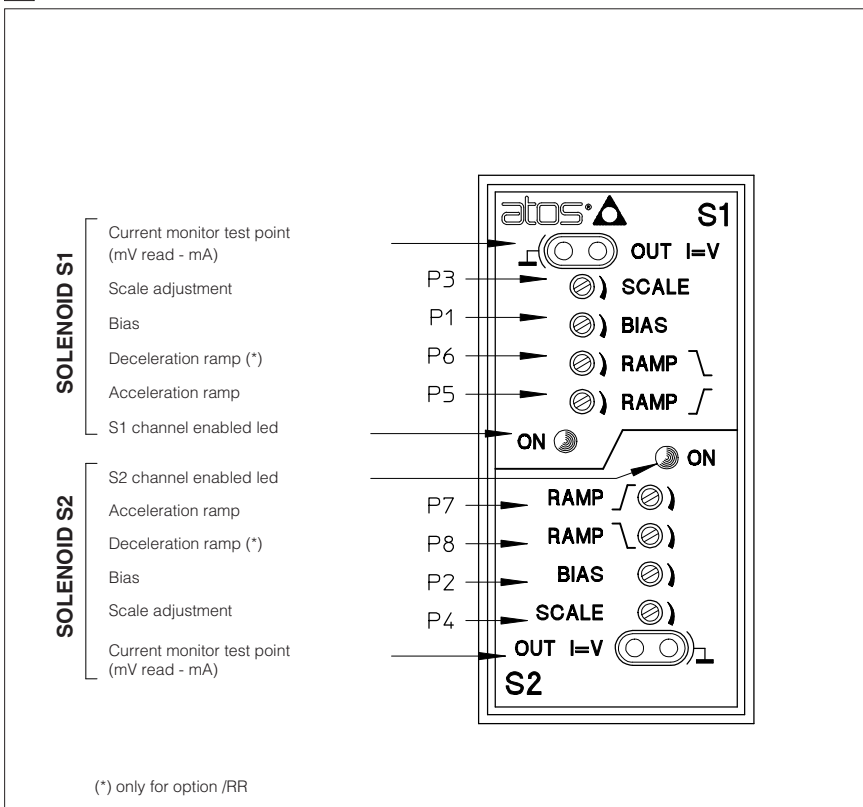

## 10 E-BM-AC-01F and 011F ADJUSTMENT

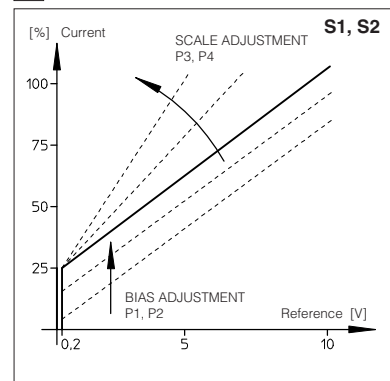

## 11 E-BM-AC-05F ADJUSTMENT

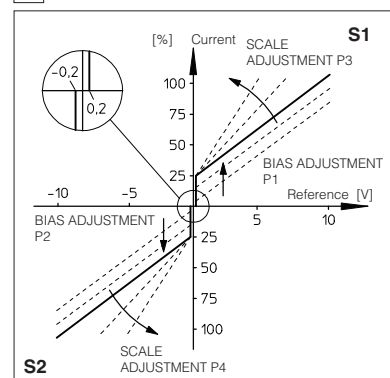

**12 IMPORTANT INSTRUCTIONS**

**ELETTROMAGNETIC COMPATIBILITY**

Atos electronic drivers and proportional valves are designed according to the 2004/108/CE Directive (Electromagnetic Compatibility) and according to EN 50081-2 (Emission) and EN 50082-2 (Immunity) standards. The electromagnetic compatibility of electronic drivers is valid only for wirings realized according to the typical electric connections shown in this technical table.

The device must be verified on the machine because the magnetic field may be different from the test conditions.

**SAFETY**

The electrical signals (for example reference signals, feedback and enable signal) of electronic drivers must not be used to realize safety conditions of the machine. This is in accordance with the provisions of European directives (Safety requirements of fluid technology systems and components-hydraulics, EN 982). Special attention must be paid to switch-on/switch-off of electronic drivers because they could produce uncontrolled movements of actuators operated by the proportional valves.

**13 WIRING BLOCK DIAGRAM**

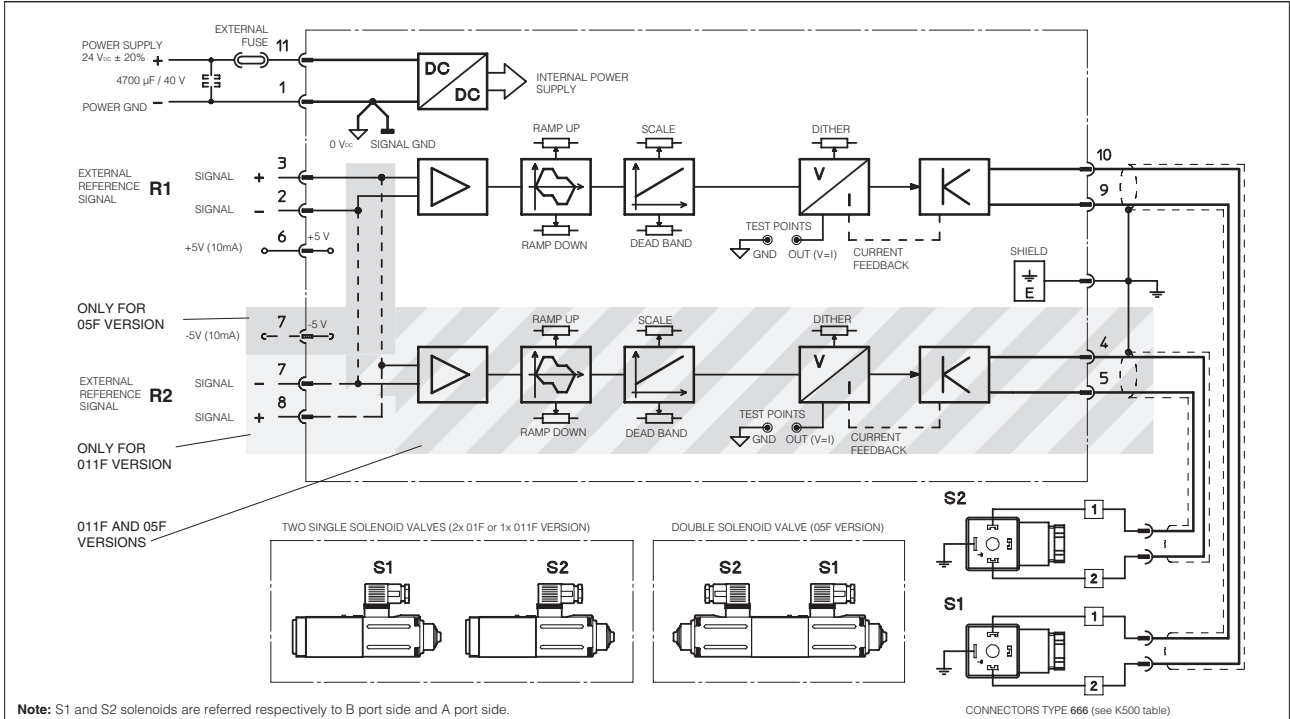

Note: S1 and S2 solenoids are referred respectively to B port side and A port side.

CONNECTORS TYPE 666 (see K500 table)

**14 E-BM-AC-01F and E-BM-AC-011F GENERAL CONNECTIONS**

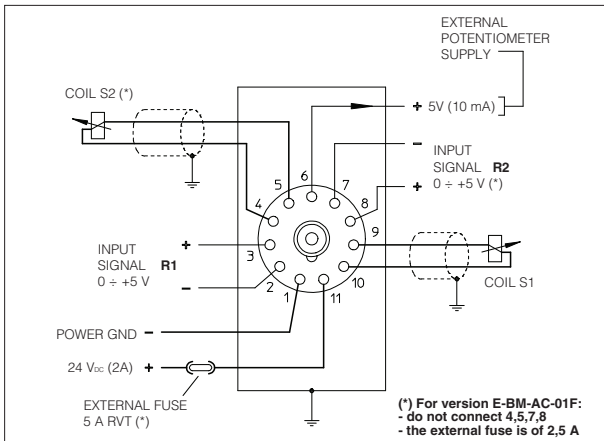

**15 E-BM-AC-05F and E-BM-AC-01F/B GENERAL CONNECTIONS**

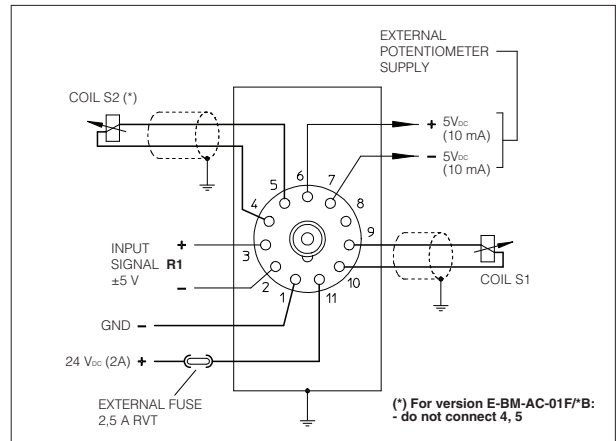

**16 EARTH CONNECTIONS**

