

# Digital electronic E-BM-AES drivers

DIN-rail panel format, for proportional valves without transducer

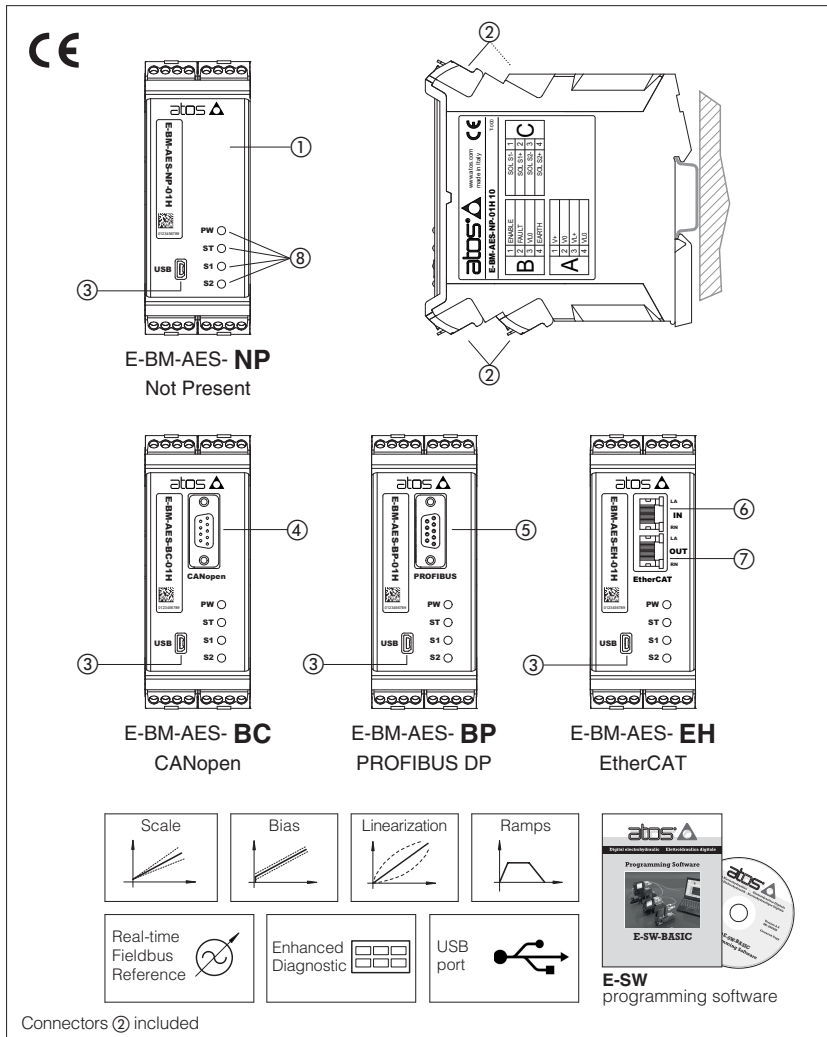

## E-BM-AES

Digital drivers ① supply and control the current to the solenoid of Atos proportional valves without transducer, according to the electronic reference input signal. The solenoid proportionally transforms the current into a force, acting on the valve spool or poppet, against a reacting spring, thus providing the valve's hydraulic regulation. Atos PC software allows to customize the driver configuration to the specific application requirements.

### Electrical Features:

- 7 fast plug-in connectors ②
- USB port ③ always present - Mini USB type B
- DB9 CANopen ④ and PROFIBUS DP ⑤ communication connector
- RJ45 EtherCAT communication connectors ⑥ and ⑦ (input - output)
- 4 leds for diagnostics ⑧ (see 4.1)
- $\pm 5$  Vdc output supply for external reference potentiometer
- Electrical protection against reverse polarity of power supply
- Operating temperature range:  $-20^{\circ} \div +60^{\circ}$
- Plastic box with IP20 protection degree and standard DIN-rail mounting
- CE mark according to EMC directive

### Software Features:

- Intuitive graphic interface
- Setting of valve's functional parameters: bias, scale, ramps, dither, PID gains
- Linearization function for hydraulic regulation
- /W option software selectable max power limitation function (see 7.7)
- Complete diagnostics of driver status
- Internal oscilloscope function
- In field firmware update through USB port

### Fieldbus Features:

- Valve direct communication with machine control unit for digital reference, diagnostics and settings
- Fieldbus execution allow to operate the valves via fieldbus or via analog signals available on the main connectors

## 1 MODEL CODE

<b>E-BM</b>	-	<b>AE</b>	-	<b>S</b>	-	<b>NP</b>	-	<b>01H</b>	/	<b>*</b>	/	<b>*</b>
Electronic driver in DIN rail panel format												
AE = for proportional valves without transducer												
S = full												
Fieldbus interface - USB port always present:												
NP = Not Present												
BC = CANopen												
BP = PROFIBUS DP												
EH = EtherCAT												
(1) set code identifies the correspondence between the driver and the relevant valve												
Options:												
A = max current limitation for Ex-proof valves												
C = current feedback $4 \pm 20$ mA for remote transducer, only in combination with option W												
I = current reference input $4 \pm 20$ mA (omit for standard voltage reference input $\pm 10$ Vdc)												
W = power limitation function												
01H = for single solenoid proportional valves												
05H = for double solenoid proportional valves												

## 2 VALVES RANGE

Valves model	Pressure				Directional		Cartridge	Flow
	RZMO	RZGO	AGMZO	AGRCZO	DHZO DKZOR	DPZO	LICZO LIMZO LIRZO	QVHZO QVKZOR
Data sheet	FS007 FS065	FS015 FS070	FS035	FS050	FS160	FS170	FS300	FS410
Driver model	<b>E-BM-AES</b>							

### 3 MAIN CHARACTERISTICS

Power supply (see 5.1, 5.4)	Nominal : +24 Vdc Rectified and filtered : $V_{RMS} = 20 \div 32 V_{MAX}$ (ripple max 10 % $V_{PP}$ )			
Max power consumption	50 W			
Current supplied to solenoids	$I_{MAX} = 2.7 A$ with +24 Vdc power supply to drive standard proportional valves (3,2 $\Omega$ solenoid) $I_{MAX} = 2.5 A$ with +24 Vdc power supply to drive ex-proof proportional valves (3,2 $\Omega$ solenoid) for <b>/A option</b>			
Reference input (see 5.2)	Voltage: maximum range $\pm 10 Vdc$ Input impedance: $R_i > 50 k\Omega$ Current: maximum range $\pm 20 mA$ Input impedance: $R_i = 500 \Omega$			
Monitor output (see 5.3)	Voltage: maximum range $\pm 5 Vdc$ @ max 5 mA			
Enable input (see 5.5)	Range : $0 \div 9 Vdc$ (OFF state), $15 \div 24 Vdc$ (ON state), $9 \div 15 Vdc$ (not accepted); Input impedance: $R_i > 87 k\Omega$			
Output supply (see 5.8)	$\pm 5 Vdc$ @ max 10 mA : output supply for external potentiometer			
Fault output (see 5.6)	Output range : $0 \div 24 Vdc$ (ON state $\equiv V_L +$ [logic power supply] ; OFF state $\equiv 0 V$ ) @ max 50 mA			
Pressure transducer (only /W option)	Power supply: +24Vdc @ max 100 mA Pressure input: voltage, maximum range $\pm 10 Vdc$ Input impedance, $R_i > 50 \Omega$ current, maximum range $\pm 20 mA$ Input impedance, $R_i = 500 \Omega$			
Alarms	Solenoid not connected/short circuit, cable break with current reference signal, over/under temperature, power supplies level, pressure transducer failure			
Format	Plastic box ; IP20 protection degree ; L 35 - H 7,5 mm DIN-rail mounting as per EN60715			
Tropicalization	Tropical coating on electronics PCB			
Operating temperature	$-20 \div +60 ^\circ C$ (storage $-25 \div +85 ^\circ C$ )			
Mass	Approx. 330 g			
Additional characteristics	Short circuit protection of solenoid current supply; current control by P.I.D. with rapid solenoid switching; protection against reverse polarity of power supply			
Electromagnetic compatibility (EMC)	According to Directive 2004/108/CE (Immunity: EN 61000-6-2; Emission: EN 61000-6-3)			
Communication interface	USB Atos ASCII coding	CANopen EN50325-4 + DS408	PROFIBUS DP EN50170-2/IEC61158	EtherCAT IEC61158
Communication physical layer	not insulated USB 2.0 + USB OTG	optical insulated CAN ISO11898	optical insulated RS485	Fast Ethernet 100 Base TX
Recommended wiring cable	LiYCY shielded cables: 0,5 mm <sup>2</sup> max 50 m for logic - 1,5 mm <sup>2</sup> max 50 m for power supply and solenoids			
Max conductor size (see 9)	2,5 mm <sup>2</sup>			

**Note:** A maximum time of 500 ms (depending on communication type) have be considered between the driver energizing with the 24 Vdc power supply and when the valve is ready to operate. During this time the current to the valve coils is switched to zero.

### 4 CONNECTIONS AND LEDS

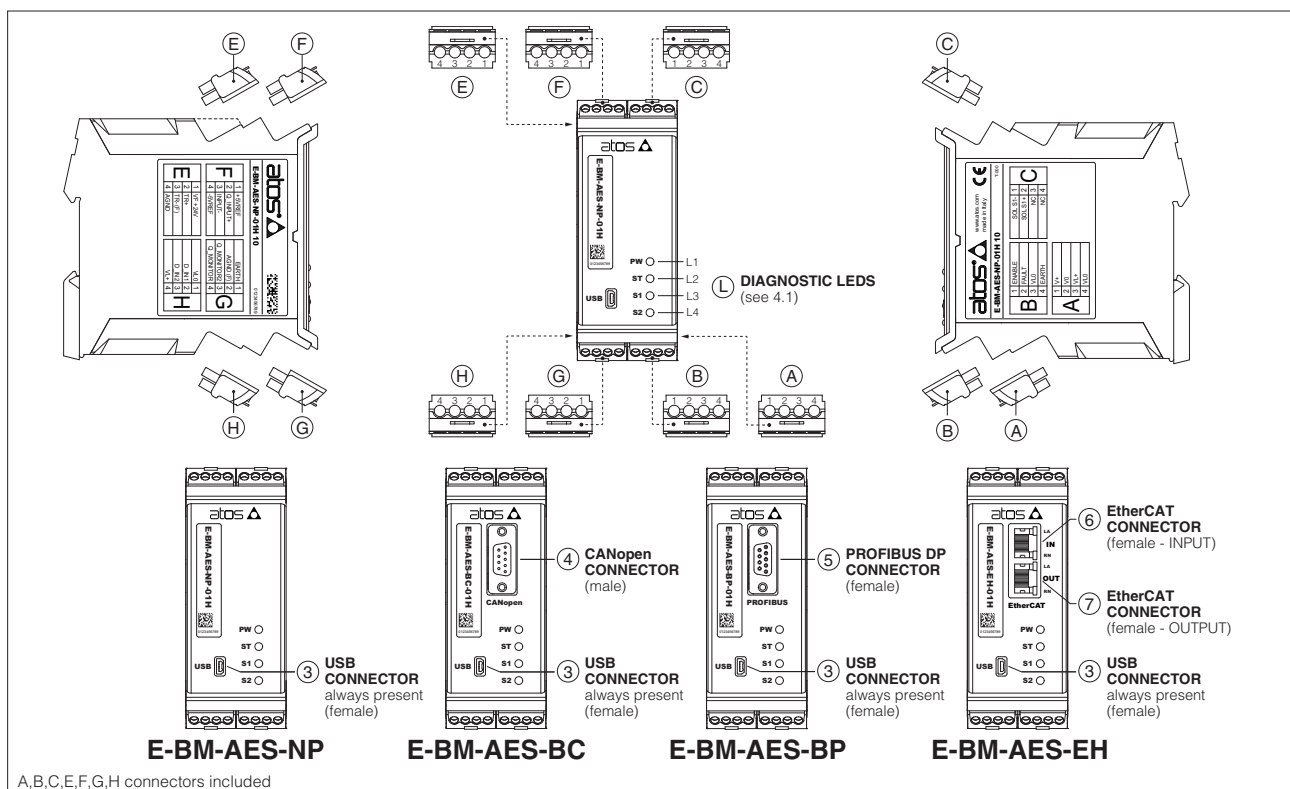

#### 4.1 Diagnostic LEDs (L)

Four leds show driver operative conditions for immediate basic diagnostics. Please refer to the driver user manual for detailed information.

LED	COLOR	FUNCTION	FLASH RATE	DESCRIPTION
L1	GREEN	PW	OFF	Power supply OFF
			ON	Power supply ON
L2	GREEN	ST	OFF	Fault present
			ON	No fault
L3 and L4	YELLOW	S1 and S2	OFF	PWM command OFF
			ON	PWM command ON

## 4.2 Connectors - 4 pin

CONNECTOR	PIN	SIGNAL	TECHNICAL SPECIFICATIONS	NOTES
<b>A</b>	A1	<b>V+</b>	Power supply 24 Vdc (see 5.1)	Input - power supply
	A2	<b>V0</b>	Power supply 0 Vdc (see 5.1)	Gnd - power supply
	A3	<b>VL+</b>	Power supply 24 Vdc for driver's logic and communication (see 5.4)	Input - power supply
	A4	<b>VLO</b>	Power supply 0 Vdc for driver's logic and communication (see 5.4)	Gnd - power supply
<b>B</b>	B1	<b>ENABLE</b>	Enable (24 Vdc) or disable (0 Vdc) the driver, referred to VLO (see 5.5)	Input - on/off signal
	B2	<b>FAULT</b>	Fault (0 Vdc) or normal working (24 Vdc), referred to VLO (see 5.6)	Output - on/off signal
	B3	<b>VLO</b>	Ground for ENABLE and FAULT	Gnd - digital signals
	B4	<b>EARTH</b>	Connect to system ground	
<b>C</b>	C1	<b>SOL_S1-</b>	Negative current to solenoid S1	Output - power PWM
	C2	<b>SOL_S1+</b>	Positive current to solenoid S1	Output - power PWM
	C3	<b>SOL_S2-</b>	Negative current to solenoid S2	Output - power PWM
	C4	<b>SOL_S2+</b>	Positive current to solenoid S2	Output - power PWM
<b>E</b>	E1	<b>VF +24V</b>	Power supply +24 Vdc	Output - power supply
	E2	<b>TR+</b>	Positive pressure transducer input signal: $\pm 10$ Vdc / $\pm 20$ mA maximum range (see 5.7) Default are 0 ÷ 10 Vdc for standard and 4 ÷ 20 mA for /C option	Input - analog signal <b>Software selectable</b>
	E3	<b>TR-</b>	Negative pressure transducer input signal for TR+	Input - analog signal
	E4	<b>AGND</b>	Common GND for transducer power and signals	
<b>F</b>	F1	<b>+5V_REF</b>	External potentiometer power supply +5 Vdc @ 10mA (see 5.8)	Output - power supply
	F2	<b>INPUT+</b>	Positive reference input signal: $\pm 10$ Vdc / $\pm 20$ mA maximum range (see 5.2) Default are $\pm 10$ Vdc for standard and 4 ÷ 20 mA for /I option	Input - analog signal <b>Software selectable</b>
	F3	<b>INPUT-</b>	Negative reference input signal for INPUT+	Input - analog signal
	F4	<b>-5V_REF</b>	External potentiometer power supply -5 Vdc @ 10mA (see 5.8)	Output - power supply
<b>G</b>	G1	<b>EARTH</b>	Connect to system ground	
	G2	<b>AGND</b>	Analog ground for MONITOR	Gnd - analog signal
	G3	<b>MONITOR2</b>	Only for /W option, 2nd monitor output signal: $\pm 5$ Vdc maximum range (see 5.3) Default is 0 ÷ 5 Vdc	Output - analog signal <b>Software selectable</b>
	G4	<b>MONITOR</b>	Monitor output signal: $\pm 5$ Vdc maximum range (see 5.3) Default is $\pm 5$ Vdc (1V = 1A)	Output - analog signal <b>Software selectable</b>
<b>H</b>	H1	<b>VLO</b>	Power supply 0 Vdc for digital input (see 5.4)	Gnd - power supply
	H2	<b>D_IN1</b>	Digital input 0 ÷ 24Vdc, referred to VLO	Input - on/off signal
	H3	<b>D_IN0</b>	Digital input 0 ÷ 24Vdc, referred to VLO	Input - on/off signal
	H4	<b>VL+</b>	Power supply 24 Vdc for digital input (see 5.4)	Output - power supply

### Pressure transducer connections - only for /W option

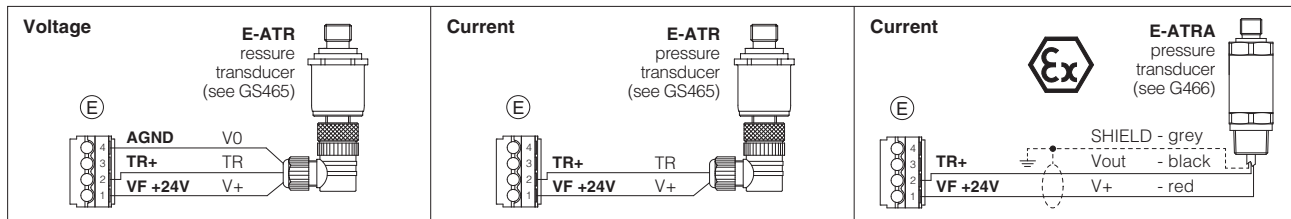

### Coils connection

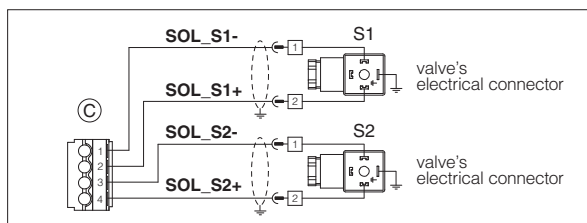

### Potentiometer connection

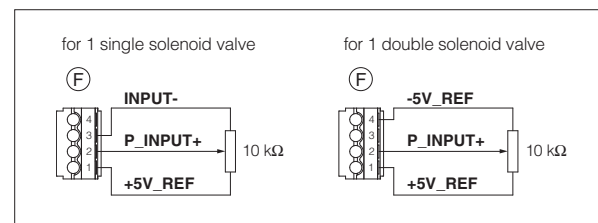

## 4.3 Communication connectors ③ - ④ - ⑤ - ⑥ - ⑦

③ USB connector - Mini USB type B always present		
PIN	SIGNAL	TECHNICAL SPECIFICATION (1)
1	<b>GND_USB</b>	Signal zero data line
2	<b>ID</b>	Identification
3	<b>D+</b>	Data line +
4	<b>D-</b>	Data line -
5	<b>+5V_USB</b>	Power supply

⑤ BP fieldbus execution, connector - DB9 - 9 pin		
PIN	SIGNAL	TECHNICAL SPECIFICATION (1)
1	<b>SHIELD</b>	
3	<b>LINE-B</b>	Bus line (low)
5	<b>DGND</b>	Data line and termination signal zero
6	<b>+5V</b>	Termination supply signal
8	<b>LINE-A</b>	Bus line (high)

④ BC fieldbus execution, connector - DB9 - 9 pin		
PIN	SIGNAL	TECHNICAL SPECIFICATION (1)
2	<b>CAN_L</b>	Bus line (low)
3	<b>CAN_GND</b>	Signal zero data line
5	<b>CAN_SHLD</b>	Shield
7	<b>CAN_H</b>	Bus line (high)

⑥ ⑦ EH fieldbus execution, connector - RJ45 - 8 pin		
PIN	SIGNAL	TECHNICAL SPECIFICATION (1)
1	<b>TX+</b>	Transmitter - white/orange
2	<b>TX-</b>	Transmitter - orange
3	<b>RX+</b>	Receiver - white/green
6	<b>RX-</b>	Receiver - green

Notes: (1) shield connection on connector's housing is recommended

## 5 SIGNALS SPECIFICATIONS

Atos proportional valves are CE marked according to the applicable directives (e.g. Immunity/Emission EMC Directive).

Installation, wirings and start-up procedures must be performed according to the general prescriptions shown in tech table **F003** and in the user manuals included in the E-SW programming software.

The electrical signals of the driver (e.g. monitor signals) must not be directly used to activate safety functions, like to switch-ON/OFF the machine's safety components, as prescribed by the European standards (Safety requirements of fluid technology systems and components-hydraulics, EN-982).

### 5.1 Power supply and wirings (V+ and V0)

The power supply must be appropriately stabilized or rectified and filtered: apply at least a 10000  $\mu$ F/40 V capacitance to single phase rectifiers or a 4700  $\mu$ F/40 V capacitance to three phase rectifiers.

A safety fuse is required in series to each driver power supply: 2,5 A time lag fuse.

### 5.2 Reference input signal (INPUT+)

The driver controls in closed loop the current to the valve proportionally to the external reference input signal.

Reference input signal is factory preset according to selected valve code, defaults are  $\pm 10$  Vdc for standard and  $4 \div 20$  mA for /I option.

Input signal can be reconfigured via software selecting between voltage and current, within a maximum range of  $\pm 10$  Vdc or  $\pm 20$  mA.

Drivers with fieldbus interface (BC, BP, EH) can be software set to receive reference signal directly from the machine control unit (fieldbus reference).

Analog reference input signal can be used as on-off commands with input range  $0 \div 24$ Vdc.

### 5.3 Monitor output signals (MONITOR and MONITOR2)

The driver generates an analog output signal (MONITOR) proportional to the actual coil current of the valve; the monitor output signal can be software set to show other signals available in the driver (e.g. analog reference, fieldbus reference).

Monitor output signal is factory preset according to selected valve code, default settings is  $\pm 5$  Vdc ( $1V = 1A$ ).

Output signal can be reconfigured via software, within a maximum range of  $\pm 5$  Vdc.

#### Option /W

The driver generates a second analog output signal (MONITOR2) proportional to the actual system pressure.

The output maximum range is  $\pm 5$  Vdc; default setting is  $0 \div 5$  Vdc.

### 5.4 Power supply for driver's logic and communication (VL+ and VL0)

The power supply to the solenoids must be appropriately stabilized or rectified and filtered: apply at least a 10000  $\mu$ F/40 V capacitance to single phase rectifiers or a 4700  $\mu$ F/40 V capacitance to three phase rectifiers.

Separate power supply (pin A3, A4) allow to cut solenoid power supply (pin A1, A2) while maintaining active diagnostics, serial and fieldbus communication.

A safety fuse is required in series to each driver power supply: 500 mA fast fuse.

### 5.5 Enable input signal (ENABLE)

To enable the driver, supply 24 Vdc on pin B1: Enable input signal allows to enable/disable the current supply to the solenoid, without removing the electrical power supply to the driver; it is used to active the communication and the other driver functions when the valve must be disabled for safety reasons. This condition does not comply with European Norms EN13849-1 (ex EN954-1).

### 5.6 Fault output signal (FAULT)

Fault output signal indicates fault conditions of the driver (solenoid short circuits/not connected, reference signal broken for  $4 \div 20$  mA input, etc.).

Fault presence corresponds to 0 Vdc, normal working corresponds to 24 Vdc.

Fault status is not affected by the Enable input signal.

### 5.7 Remote pressure transducer input signal (TR+ and TR-) - only for /W option

Analog pressure transducers can be directly connected to the driver.

Analog input signal is factory preset according to selected valve code, defaults are  $0 \div 10$  Vdc for standard and  $4 \div 20$  mA for /C option.

Input signal can be reconfigured via software selecting between voltage and current, within a maximum range of  $\pm 10$  Vdc or  $\pm 20$  mA.

Note: transducer feedback can be read as a digital information through fieldbus communication - software selectable.

### 5.8 Output supply for external potentiometer ( $\pm 5V\_REF$ )

The reference analog signal can be generated by one external potentiometer directly connected to the driver, using the  $\pm 5$  Vdc supply output available at pin F1 and F4.

### 5.9 Possible combined options: /AI, /AW, /IW, /AIW, /ACW, /CIW, /ACIW, /CW

## 6 PROGRAMMING TOOLS - see tech table GS500

Valve's functional parameters and configurations, can be easily set and optimized using Atos E-SW programming software connected via USB port to the digital driver. For fieldbus versions, the software permits valve's parameterization through USB port also if the driver is connected to the central machine unit via fieldbus.

The software is available in different versions according to the driver's options:

<b>E-SW-BASIC</b> support:	NP (USB)	PS (Serial)	IR (Infrared)
<b>E-SW-FIELDBUS</b> support:	BC (CANopen)	BP (PROFIBUS DP)	EH (EtherCAT)
	EW (POWERLINK)		
<b>E-SW-*/PQ</b> support:	valves with SP, SF, SL alternated control (e.g. E-SW-BASIC/PQ)		

### WARNING: drivers USB port is not isolated!

The use of isolator adapter is highly recommended for PC protection (see table **GS500**)

Free programming software, web download:

**E-SW-BASIC** web download = software can be downloaded upon web registration at [www.download.atos.com](http://www.download.atos.com) ; service and DVD not included  
Upon web registration user receive via email the Activation Code (software free license) and login data to access Atos Download Area

DVD programming software, to be ordered separately:

**E-SW-\*** DVD first supply = software has to be activated via web registration at [www.download.atos.com](http://www.download.atos.com) ; 1 year service included  
Upon web registration user receive via email the Activation Code (software license) and login data to access Atos Download Area

**E-SW-\*-N** DVD next supplies = only for supplies after the first; service not included, web registration not allowed  
Software has to be activated with Activation Code received upon first supply web registration

**Atos Download Area:** direct access to latest releases of E-SW software, manuals, USB drivers and fieldbus configuration files at [www.download.atos.com](http://www.download.atos.com)

**USB Adapters, Cables and Terminators, can be ordered separately**

### USB connection

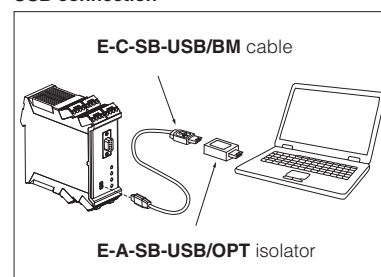

## 7 MAIN SOFTWARE PARAMETER SETTINGS

The following is a brief description of the main settings and features of digital drivers.

For a detailed descriptions of available settings, wirings and installation procedures, please refer to the user manual included in the E-SW programming software:

**E-MAN-BM-AES** - user manual for **E-BM-AES**

### 7.1 Scale

Scale function allows to set the maximum current supplied to the solenoid, corresponding to the max valve regulation, at maximum reference signal value.

This regulation allows to adapt the maximum current supplied from the driver to the specific nominal current of the proportional valves to which the driver is coupled; it is also useful to reduce the maximum valve regulation in front of maximum reference signal.

Two different Scale regulations are available for double solenoid valves: ScaleA for positive reference signal and ScaleB for negative reference signal.

### 7.2 Bias and Threshold

Proportional valves may be provided with a dead band in the hydraulic regulation corresponding to their switch-off status.

This dead band discontinuity in the valve's regulation can be compensated by activating the Bias function, which adds a fixed preset Bias value to the reference signal (analog or fieldbus external input).

The Bias function is activated when the reference signal overcomes the Threshold value, preset into the driver.

The Bias setting allows to calibrate the Bias current to the specific proportional valve to which the driver is coupled.

The Threshold setting is useful to avoid undesired valve regulation at zero reference signal when electric noise is present on the analog input signal: smaller threshold reduces the reference signal dead band, greater values are less affected by electric noise presence.

If fieldbus reference signal is active (see 5.2), threshold should be set to zero.

Two different Bias regulations are available for double solenoid valves: positive reference signals activate BiasA and negative reference signals activate BiasB.

Refer to the programming manuals for a detailed description of other software selectable Bias functions.

### 7.3 Offset

Proportional valves may be provided with zero overlapping in the hydraulic regulation corresponding to zero reference input signal (valve's central spool position).

The Offset function allows to calibrate the Offset current, required to obtain valve's spool central position, to the specific hydraulic system setup (e.g. valve applied to cylinder with differential areas).

### 7.4 Ramps

The ramp generator allows to convert sudden change of electronic reference signal into smooth time-dependent increasing/decreasing of the current supplied to the solenoid.

Different ramp mode can be set:

- single ramp for any reference variation
- two ramps for increasing and for decreasing reference variations
- four ramps for positive/negative signal values and increasing/decreasing reference variations

Ramp generator is useful for application where smooth hydraulic actuation is necessary to avoid machine vibration and shocks.

If the proportional valve is driven by a closed loop controller, the ramps can lead to unstable behaviour, for these applications ramp function can be software disabled (default setting).

### 7.5 Linearization - E-SW level 2 functionality

Linearization function allows to set the relation between the reference input signal and the controlled valve's regulation.

Linearization is useful for applications where it is required to linearize the valve's regulation in a defined working condition.

### 7.6 Variable Dither

The dither is the frequency modulation of the current supplied to the solenoid. To reduce the hysteresis should be selected a lower value of frequency, despite a lower regulation stability, because a small vibration in the valve regulating parts considerably reduces static friction effects.

To improve the regulation stability, should be selected a high value of frequency, despite a higher hysteresis. This solution in some application can lead to vibration and noise. Normally, the right setting is a compromise and depends on system setup.

E-BM-AES drivers allow to realize a variable dither frequency that linearly depends on the demanded current: variable dither frequency allows an higher degree to optimize the valve hysteresis.

### 7.7 Hydraulic Power Limitation - only for /W option

Digital E-BM-AES drivers with /W option electronically perform hydraulic power limitation on:

- direct and pilot operated flow control valves
- direct and pilot operated directional control valves + mechanical pressure compensator
- variable displacement pumps with proportional flow regulator (e.g. PVPC-\*-LQZ, tech table **A170**)

The driver receives the flow reference signal by the analog external input INPUT+ (see 5.2) and a pressure transducer, installed in the hydraulic system, has to be connected to the driver's analog input TR (see 5.7).

When the actual requested hydraulic power  $p \times Q$  (TR x INPUT+) reaches the max power limit ( $p_1 \times Q_1$ ), internally set by software, the driver automatically reduces the flow regulation of the valve. The higher is the pressure feedback the lower is the valve's regulated flow:

$$\text{Flow regulation} = \text{Min} \left( \frac{\text{PowerLimit [sw setting]}}{\text{Transducer Pressure [TR]}} ; \text{Flow Reference [INPUT+]} \right)$$

### 7.8 Internal Reference Generation

Internal generation of reference values is selectable via software.

In this mode the 2 digital inputs of the driver (D\_IN0 and D\_IN1) allow to activate the desired internal reference signal, among the different driver's stored values: external control unit can thus manage complex machine profile by simple switching the reference signal, by 2 digital inputs.

### 7.1, 7.2 - Scale, Bias & Threshold

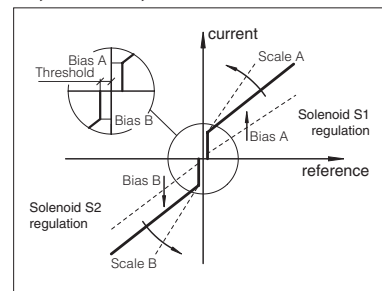

### 7.3 - Offset

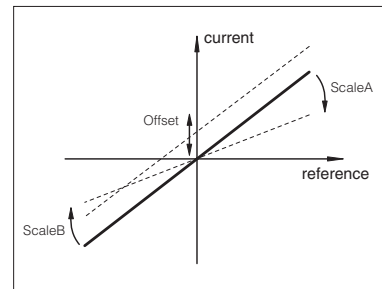

### 7.4 - Ramps

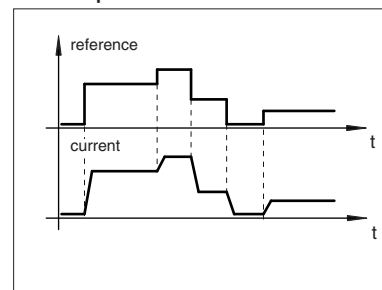

### 7.5 - Linearization

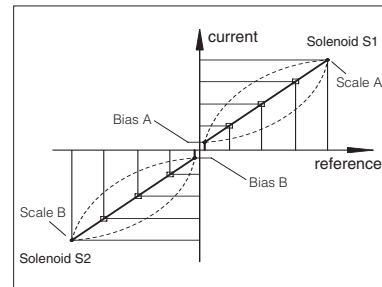

### 7.6 - Variable Dither

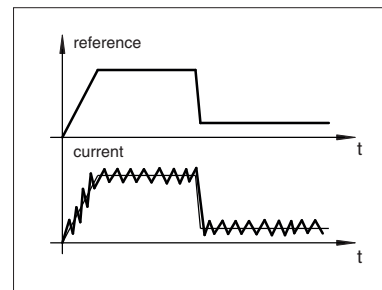

### 7.7 - Hydraulic Power Limitation

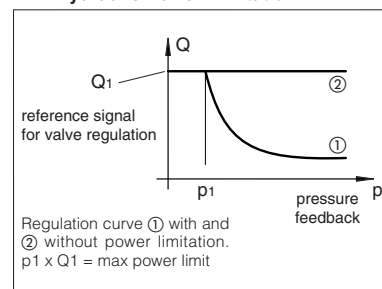

**8 OVERALL DIMENSIONS [mm]**

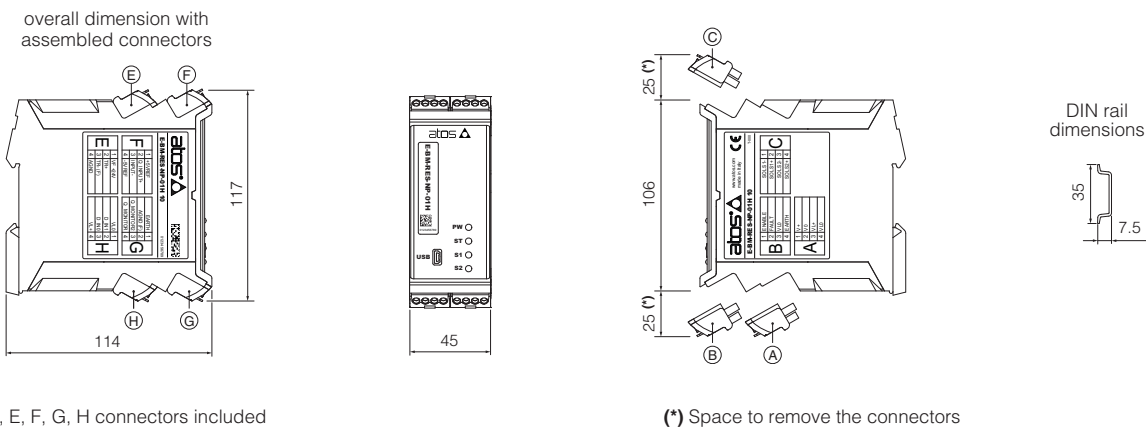

**9 INSTALLATION**

**To wire cables in the connectors:**

1. insert cable into the termination
2. turn screw with a screwdriver

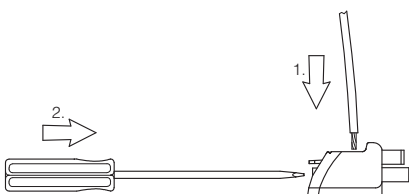

**Note:** max conductor size: 2,5 mm<sup>2</sup>  
tightening torque: 0,4 ÷ 0,6 Nm

**To unlock the driver from the DIN rail:**

1. pull down the locking slide with a screwdriver
2. rotate up the driver

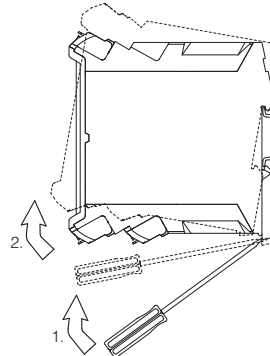

**To extract the connectors:**

1. push lever
2. pull connector

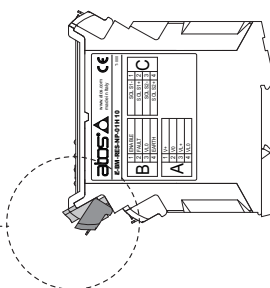
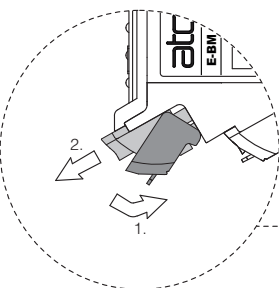

**To insert the connectors:**

1. push the connector in its slot

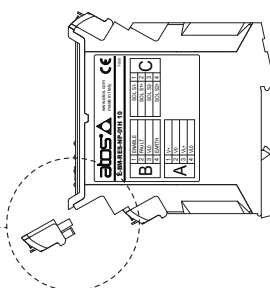
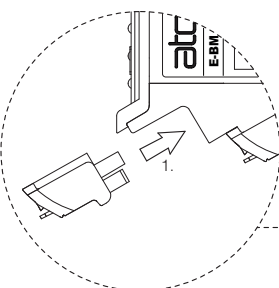

**Note:** all connectors are supplied with a mechanical coding. This feature ensures a unique insertion of each connector in the own slot. (eg. connector A can not be inserted into connector slot of B, C, E, F, G, H)