



Amplifier for proportional valves PEK SRA

FEATURES

- Amplifier in Euroboard format
- Control of proportional valves with 1 coil in closed loop
- Linear control with minimal hysteresis

SPECIFICATIONS

Electric supply:	DC 22 - 30 VDC (rectified and filtered, small ripple)
Power:	20 - 45 W (terminals 2a/2c - 4a/4c)
Output:	max. 1 A
Setpoint signal:	
- Voltage	0 - 10 V
- Current	4 up to 20 mA (by using a potentiometer $R > 200 \Omega$!)
Input impedance of the Setpoint signal:	
- Voltage	10 k Ω
- Current	250 Ω
Board format:	Euroboard 100 x 160 x 35
Board connector:	DIN 41612-D 32
Ambient temperature:	0 up to 50° C
Electro-magnetic capability (EMC):	
- Output	according to CEI EN 61000-6-4
- capability	according to CEI EN 61000-6-2
Protection:	according to standards 2004/108/CEE
	Over-voltage and inverse polarity protection fuse (3,15 A)
Weight:	0,20 kg

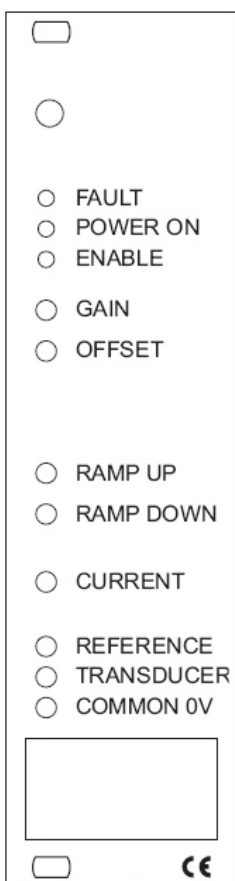

The diagram shows the curve of the position of the piston in function of the setpoint signal.

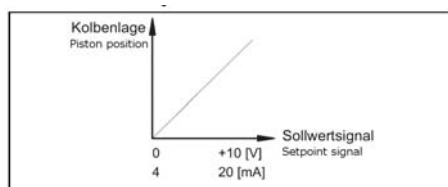

Block diagram

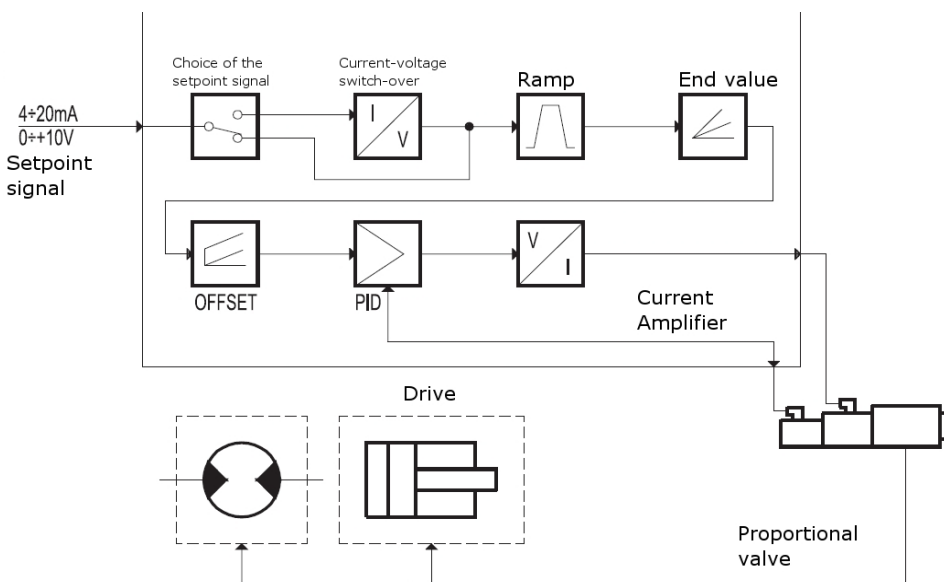

The amplifier PEK SRA is an electronic control unit in Euroboard format and is used to control proportional valves with one coil and transducer.

It carries out the control of the position of the valve piston as a function of the input setpoint signal, so it allows a linear control and a minimal hysteresis.

On the front panel are LED's to indicate the operating status of the drive electronics and a potentiometer resp. sockets to adjust the amplifier to the valve application.

1. CONTROLS AND INDICATORS

1.1 - FAULT (fault display)

The red LED indicates the operational status of the transducer:
OFF - Normal

ON - failures in the transducer or cable failure.

In the "FAULT" mode, the amplifier is disabled, so that the solenoids are de-energized and the valve is spring-centered in the normal position. The green LED "ENABLE" disappears and the loop (via relay on amplifier) between the terminals 6a and 6c is interrupted.

1.2 - POWER ON (power supply)

The yellow LED provides feedback on the power supply of the trigger electronics:

ON - Supply voltage ok

OFF - no or inadequate power supply or fuse has tripped

1.3 - ENABLE (enable)

A signal voltage (22-30 VDC) at terminal 24c releases the final stage. The output stage release is confirmed by the illumination of the green LED "ENABLE" and closing of the loop (via relay on amplifier) between 6a and 6c.

The green LED indicates:

ON - amplifier released

OFF - amplifier not released

1.4 - GAIN (gain setting for solenoid current)

The potentiometer "GAIN" determines the ratio between solenoid input setpoint and solenoid current of the power amplifier. The maximum current of the amplifier is limited to 1A. Standard setting, see Item 4.

By turning clockwise the solenoid current and thereby the flow rate is increased within the hydraulic limitations.

1.5 - OFFSET (Setting of offset for the solenoid current)

The potentiometer "OFFSET" allows the setting of an offset current e.g. to minimize the valve coverage. If the input signal exceeds a threshold of 150mV (or 4.24 mA), the amplifier puts out the adjusted offset current. If the input signal is in the range of 150 mV (.4,24 or 4 mA) the solenoid current is 25mA.

The setting range is from 0 to 0.5 A.

By turning clockwise, the current value is increased.

A change in the OFFSET setting affects the GAIN setting.

1.6 - RAMP UP / RAMP DOWN (ramp module)

The potentiometers "RAMP UP" and "RAMP DOWN" determine the rise and fall times of the setpoint signal of a setpoint change at the entry of the ramp module.

The adjustment range is between 0.03 to 7 seconds.

The ramp function can be disabled via a signal voltage (22-30 VDC) at terminal 16a. In this case, the ramp time is generally 10 ms.

By turning clockwise the ramp time is increased.

2 - SIGNAL MEASUREMENT

2.1 - CURRENT (test socket for solenoid current)

This is a voltage signal with reference point "COMMON 0V". The conversion factor is $1VCC = 1A$.

2.2 - REFERENCE (test point for controller input)

Inverted setpoint after the ramp module. Following is valid when using a current input signal : $4mA$ and $20mA = 0V = -10V$

2.3 - TRANSDUCER (test point for signal of the transducer)

Direct readout of the transducer-signal with voltage range of $+ / - 4.8V$ (tolerance 200mV)

2.4 - COMMON 0 V (reference potential)

Reference potential for test sockets 2.1 - 2.3

3 - INSTALLATION

The amplifier is suitable for rack mounting or for mounting in a PCB holder with an interface type DIN 41 612 - Form D 32. Wiring recommendation: supply of the amplifier and connection to the solenoid coil with cable cross section of 1 to 2.5 mm². The cross section depends on the length of the cable. For signal lines use shielded, grounded cables at the drive electronics.

NOTE 1

To meet the EMC requirements, it is important that the electrical wiring is conform to the block diagram.

In general, the valve and the connecting cable to the amplifier are to be operated far from interference sources such as power lines, electric motors, inverters and electrical switching equipment.

In rooms with special electromagnetic interference sources, a complete shielding of the cable may be needed.

3.1 - Supply

The amplifier requires a supply voltage of 22-30 VDC and has a power consumption of up to 45 W (terminals 2a/2c - 4a/4c).

3.2 - Electrical protection devices

The amplifier is equipped with an over-voltage and inverse polarity protection.

The power circuits are protected by a quick fuse of 3.15 A F. Position on printed board, see Dimensions, page 4

3.3 - Setpoint signal

The amplifier is designed for input setpoint values in the form of voltage signals (0 .. +10 V) or current signals (4 .. 20mA). Details on WIRING DIAGRAM see page 4. Assignment of setpoint values, see page 1

If the setpoint signal is transferred by a potentiometer, verify that its resistance value is bigger than 200Ω.

4 - STANDARD SETTING

The amplifier is preset:

- "GAIN" value signal +10 V (or 20 mA) corresponds to the maximum opening of the valve and approximately -5V at test point "TRANSDUCER".

In the open control circuit the GAIN settings are corresponding a solenoid current of about 1A at max. setpoint.

- "OFFSET": zero.
- "RAMP UP" and "RAMP DOWN" means, at minimum.
- SW1 in position V
- SW2 in position S
- SW3 in position AC
- S1 in position N
- Dither (PWM) = 230 Hz

5 - ADJUSTMENTS TO FRONT PANEL

The following adjustments can be made via the front panel:

a) Setting the OFFSET

- Set the potentiometer "GAIN A" and "GAIN B" to the minimum value.
- Set the setpoint to +10 V (or 20 mA)
- Turn the potentiometer "OFFSET" so that the valve is set to the desired initial value (see valve description).

b) Setting the GAIN

- Set the setpoint signal to +10 V (or 20 mA)
- Turn the potentiometer "GAIN" to the desired maximum value to adjust the controlled variable (hydraulic parameter).

c) Setting the ramp of the RAMP module

- Turn the potentiometer "RAMP UP" and "RAMP DOWN" so that with a change of the setpoint signal the desired delay in the response of the valve is achieved.

6 - ADJUSTMENTS TO AMPLIFIER

In the dimensional drawing (see page 4) four different switch groups are named: SW 1 - SW 2 - SW 3 and S1. These serve to parameterize the amplifier.

Before using the switches the amplifier has to be unplugged from the power supply. All switches of a group must have the same switching position.

SELECTION

of voltage or current signal as input setpoint value:

(Group SW1, three separate switches)

- For the voltage signal adjust to V
- For the current signal adjust to I

SELECTION OF THE SINGLE POLE OR DIFFERENTIAL setpoint signal (Group SW 2, only one switch)

- for the single-phase setpoint signal (terminal 12c connected to ground) please adjust S. The position of S is used when the setpoint signal is generated by the amplifier via a potentiometer (wiper at 12a). See page 4
- For the differential setpoint signal please adjust D. This is used when the setpoint signal comes from an analogue output module of a PLC or CNC.

CHOICE OPEN OR CLOSED LOOP

(SW group 3, two single switch)

- For the closed-loop set AC
- For open-loop (controlled use), set AA

SELECTION inversion of the actual-value-signal

(Group S1, only one switch)

- For direct acting valves type SRA please choose N
- For Pilot operated valves please choose D

In case of transducer failures, it is possible to run an operation with an open control chain – please choose AA at SW 3. In this state, the LED ENABLE is illuminated, the loop (via relay on amplifier) between the terminals 6a and 6c is interrupted and the FAULT LED is illuminated to indicate an error.

CONTROL OF THE FREQUENCY DITHER

Over the potentiometer PT7 the dither frequency can be specified. The setting range lies between 80 and 1600Hz. The dither signal is used to minimize the valve hysteresis and has to be optimized during setting in motion. By turning clockwise, the frequency is increased.

Standard models
PEK-SRA-D1XX
 Other types on request

Part No.
3493287

Block DIAGRAM

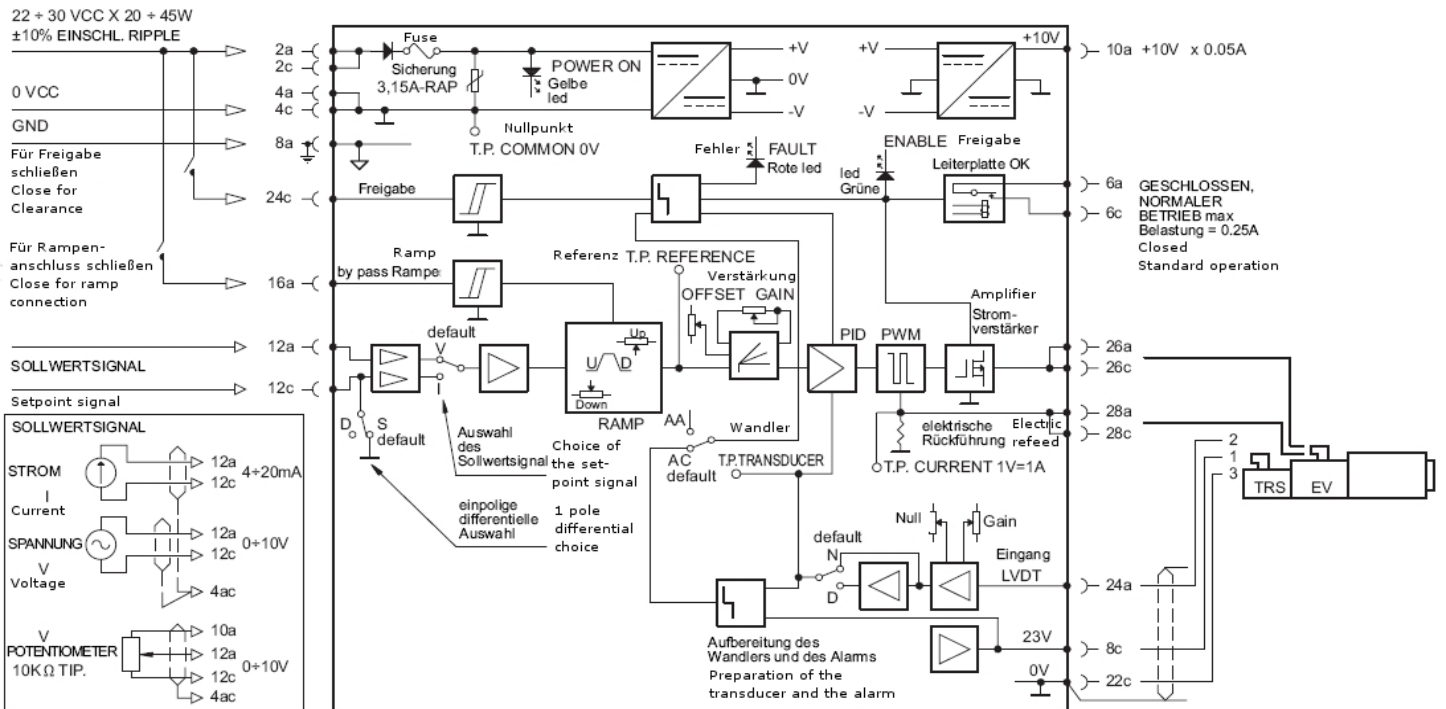

DIMENSIONS

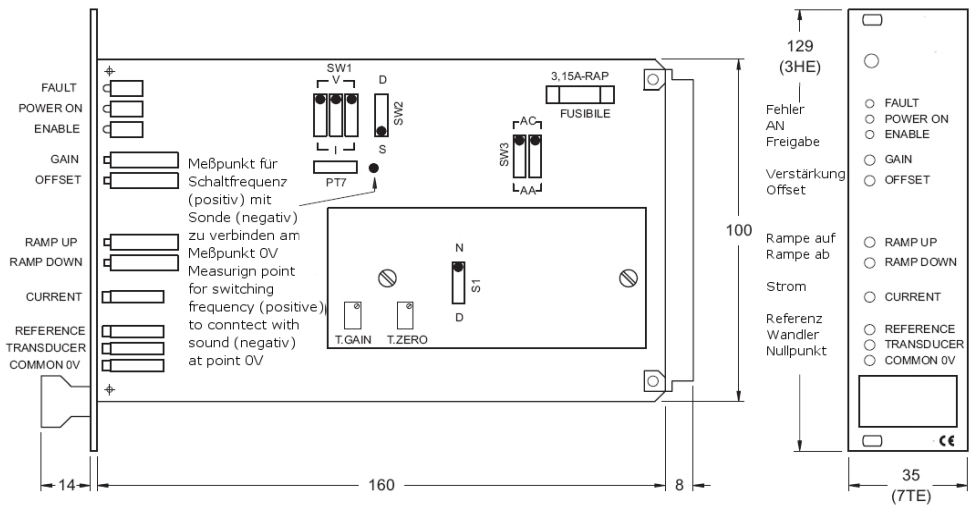

Annotation
 The technical information in this brochure are relating to the operating conditions and applications. At deviant applications and/or operating conditions please contact the technical dept. Technical information are subject to technical modifications.

HYDAC Fluidtechnik GmbH
 Justus-von-Liebig-Str. 5
 66280 Sulzbach / Saar
 Tel.: 06897 / 509 -0
 Fax: 06897 / 509 -598
 Email: flutec@hydac.com