



## Proportional Pressure Relief Valve

### pilot operated

### Subplate to ISO6264

### VP-PDBP10

#### SYMBOL

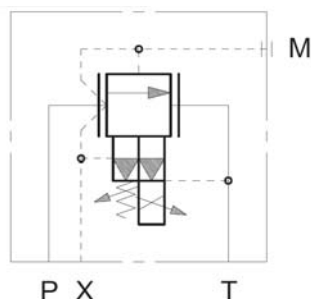

**up to 350 bar**  
**up to 200 l/min**

#### FUNCTION

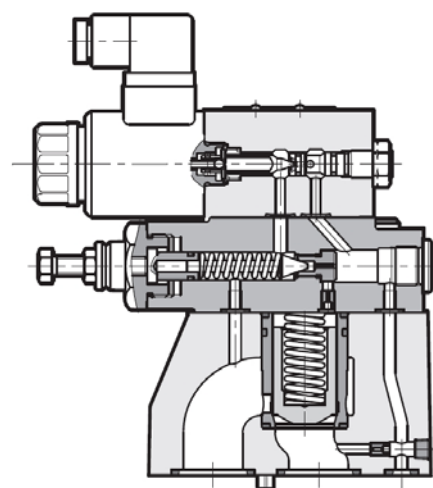

#### FEATURES

- Hole pattern to ISO 6264-06, Nominal size 10
- Pilot operated pressure relief valve with Proportional coil
- Electronic control by PEM-XD see brochure 5.249.2.0

#### SPECIFICATIONS

Operating pressure:	max. 350 bar
Flow rate:	max. 200 l/min
Hysteresis:	< 5 %
Repeatability:	< +/- 1,5 %
Operating fluid:	hydraulic oil to DIN 51524 part 1 and 2
Operating fluid temp. range:	-20°C up to max. +80°C
Ambient temperature range:	-10°C up to max. +50°C
Viscosity range:	10 – 400 mm <sup>2</sup> /s is recommended
Filtration:	Class 20/18/15 according to ISO 4406 class 18/16/13
Switching time:	On: 120 ms Off: 90 ms
Type of voltage:	DC voltage
Nominal current:	0,86 A at 24V DC (12 V on request)
Resistance at 20°C:	17,6 Ohm at 24V DC (12V on request)
Coil duty rating:	100% (Continuous)

Electro magnetic suitability: (EMC)	Emissions to EN 50081-1 suitability to EN 50082-2 to Norm 89/336 CEE
IP rating:	IP65 (if plug is mounted correctly)
Installation:	see installation hints below
Note:	Bleed system and valve before setting in motion
Hole pattern:	according to ISO 6264-06
Weight:	5,0 kg

#### Installation:

We recommend to install the valve horizontally or vertically with coil at the lower end. If installed vertically upwards please consider changes of minimal regulated pressure! Pay attention that no air is in the system. In some applications the coil-support has to be bled by the screw at the support. Line T has to be connected directly to tank. Every counter-pressure on line T has to be added to the regulated pressure. Maximal permitted counter-pressure at T: 2 bar.

The fixation of the valve will be done by screws or tension rods on a plane surface which surface finish is equal or higher than the valves finish. If the surface finish is not as specified above, leakages may occur.

## PERFORMANCE

measured at  $\nu = 36 \text{ mm}^2/\text{s}$  and  $T_{\text{oil}} = 50^\circ \text{ C}$

### Pressure reducing diagram $p=f(I)$

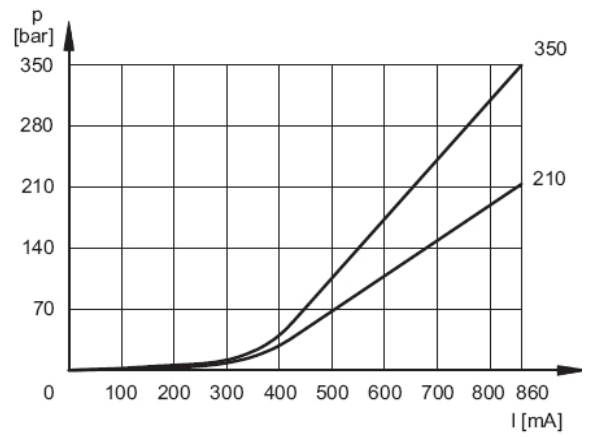
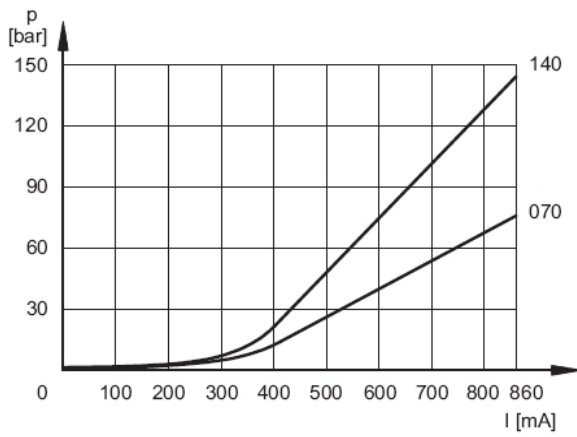

### Minimal regulated pressure $p_{\text{min}}=f(Q)$

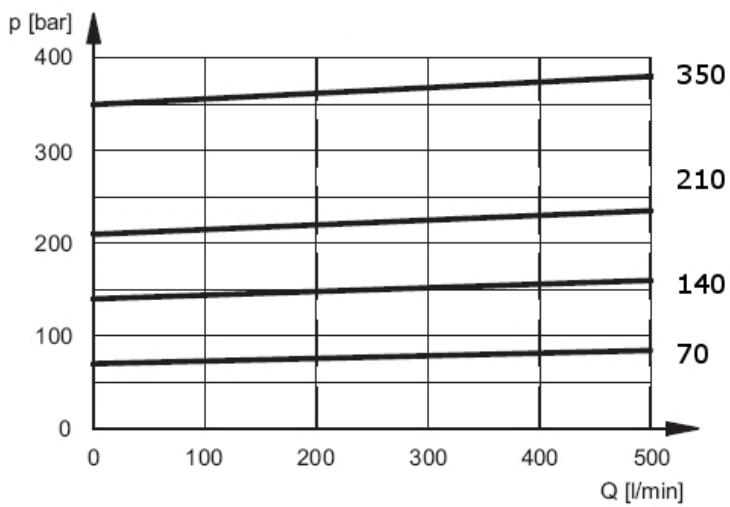

### Pressure changes $p_{\text{max}} = f(Q)$

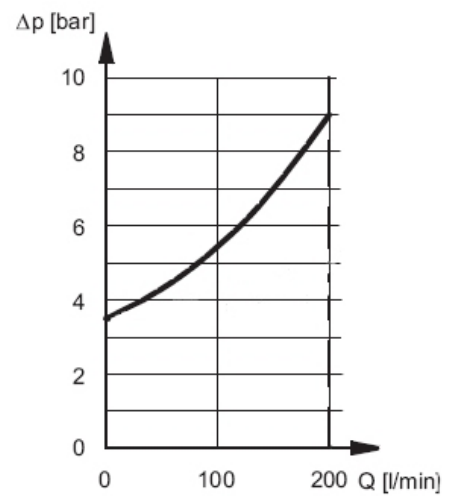

### Standard models

VP-PDBP10 070 D01-24PG/V  
 VP-PDBP10 140 D01-24PG/V  
 VP-PDBP10 210 D01-24PG/V  
 VP-PDBP10 350 D01-24PG/V  
 Other models on request

### Part No.

3541051  
 3541085  
 3541086  
 3541088

### MODEL CODE

VP-PDBP10 070 D01 - 24PG /V

**Name and size** \_\_\_\_\_  
 Proportional pressure relief valve NW 10

**Pressure ranges** \_\_\_\_\_  
 070 = up to 70 bar  
 140 = up to 140 bar  
 210 = up to 210 bar  
 350 = up to 350 bar

**Type** \_\_\_\_\_  
 D01 = Standard

**Nominal voltage** \_\_\_\_\_  
 24 = DC voltage 24 Volt  
 Other voltages on request

**Plug type** \_\_\_\_\_  
 PG = DIN plug to EN155301-803

**Seal material** \_\_\_\_\_  
 V = FKM (Standard)  
 N = NBR

### DIMENSIONS

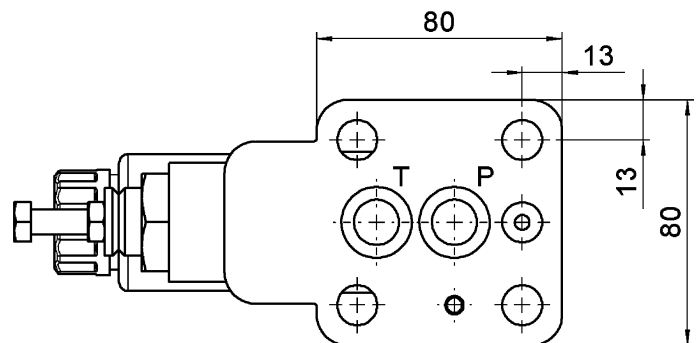
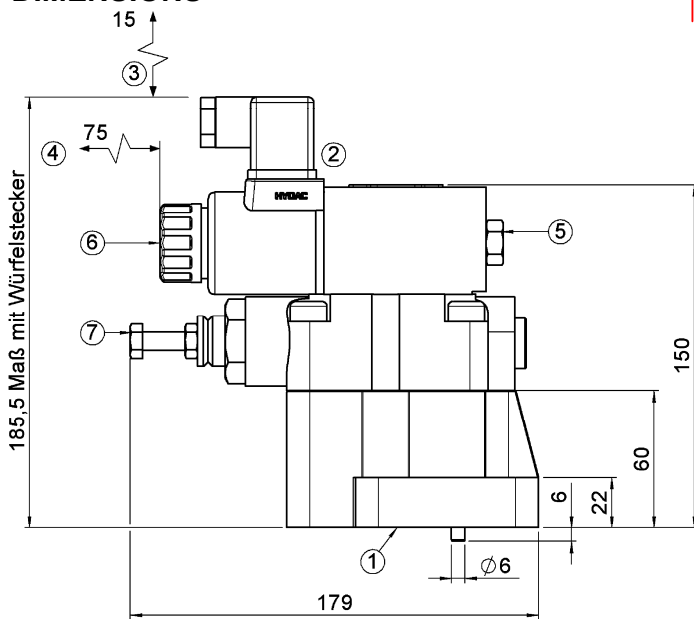

- 1) Mounting plate with O-rings:  
 2x O-Ring 17,86 x 2,62 FKM  
 1x O-Ring 9,19 x 2,62 FKM
- 2) DIN plug to EN175301-803 (in scope of delivery)
- 3) Free space for mounting the plugs
- 4) Free space for mounting the coil
- 5) Adjustment sealed
- 6) Bleeding screw
- 7) Pressure relief valve

Fastening screws: 4x Allen key M12x40 10.9  
 Torque: 70 Nm + 5 Nm

All dimensions in mm.  
 Fastening elements are not in scope of delivery.

### Mounting plate to ISO 6264-06-09-01-97

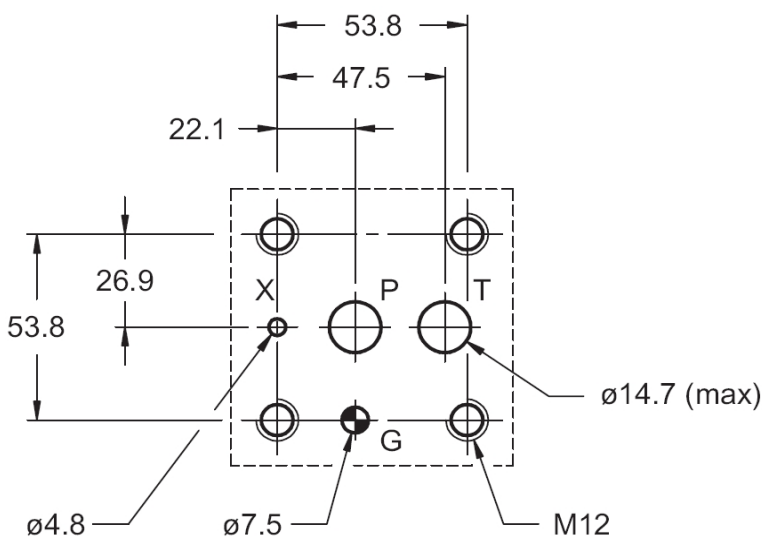

**Annotation**  
 The technical information in this brochure are relating to the operating conditions and applications. At deviant applications and/or operating conditions please contact the technical dept. Technical information are subject to technical modifications.

HYDAC Fluidtechnik GmbH  
 Justus-von-Liebig-Str. 5  
 66280 Sulzbach / Saar  
 Tel.: 06897 / 509 -0  
 Fax: 06897 / 509 -598  
 Email: flutec@hydac.com

