

19 l/min
350 bar

FUNCTION

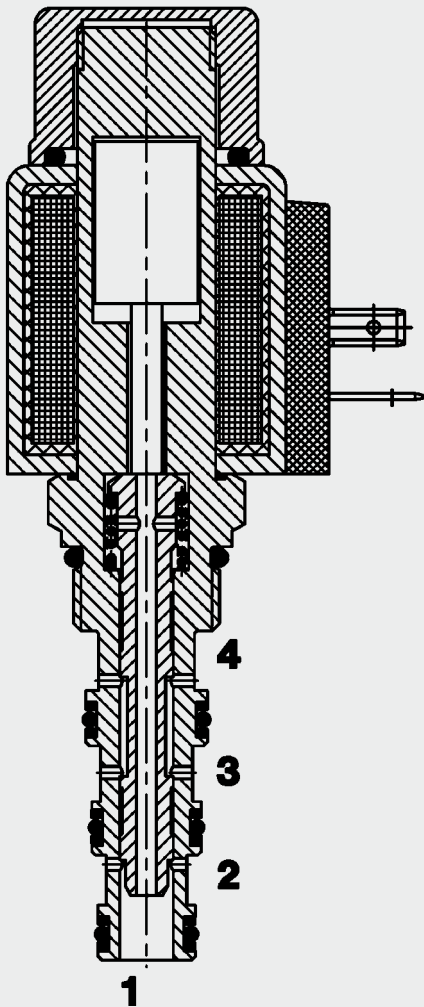

When the solenoid coil is not energized, there is free flow through the valve from port 3 to 4 or from 4 to 3 and also from port 2 to 1 or from 1 to 2. In the energized mode, the valve blocks flow in all directions.

4/2 Solenoid Directional Valve **UNF** Spool Type - Direct-Acting SAE-08 Cartridge – 350 bar

WK08A-01

FEATURES

- External surfaces zinc-plated and corrosion-proof
- Hardened and ground internal valve components to ensure minimal wear and extended service life
- Coil seals protect the solenoid system
- Wide variety of connectors available
- Excellent switching performance by high power HYDAC solenoid
- Low pressure drop due to CFD optimized flow path

SPECIFICATIONS

Operating pressure:	max. 350 bar
Nominal flow:	19 l/min (Consult HYDAC for flow rates above 207 bar)
Internal leakage:	max. 90 cm ³ /min at 250 bar and 34 mm ² /s
Media operating temperature range:	min. -20 °C to max. +100 °C
Ambient temp. range:	min. -20 °C to max. +60 °C
Operating fluid:	Hydraulic oil to DIN 51524 Part 1 and 2
Viscosity range:	min. 7.4 mm ² /s to max. 420 mm ² /s
Filtration:	Class 21/19/16 according to ISO 4406 or cleaner
MTTF _d :	150 years (see "Conditions and instructions for valves" in brochure 5.300)
Installation:	No orientation restrictions
Materials:	Valve body: free-cutting steel Piston: hardened and ground steel Seals: NBR (standard) FKM (optional, media temperature range -20 °C to +120 °C) Back-up rings: PTFE Coil: Steel/Polyamide
Cavity:	FC08-4
Weight:	Valve complete 0.38 kg Coil only 0.19 kg

Electrical data

Type of voltage:	DC solenoid, AC voltage is rectified using a bridge rectifier built into the coil
Current draw at 20 °C:	1.5 A at 12 V DC 0.8 A at 24 V DC
Voltage tolerance:	± 15% of the nominal voltage
Coil duty rating:	Continuous up to max. 115% of the nominal voltage at 60 °C ambient temperature
Coil type:	Coil...-40-1836

DIMENSIONS

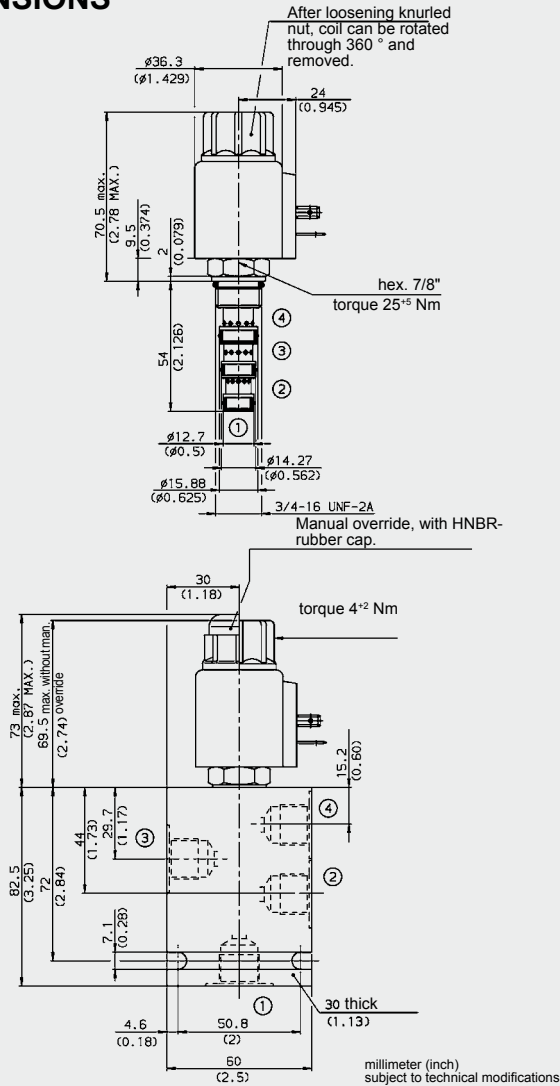

MODEL CODE

WK08A-01 M-C-N-24 DG

Basic model _____
Directional spool valve, UNF

Type _____
01 = standard

Manual override _____
no details = without manual override
M = manual override

Body and ports* _____
C = cartridge only
SB3 = G3/8 ports, steel body
AB3 = G3/8 ports, aluminium body

Seals _____
N = NBR
V = FKM

Coil voltage _____
DC voltages

12 = 12 V DC
24 = 24 V DC

AC voltages (bridge rectifier built into the coil)
115 = 115 V AC
230 = 230 V AC

Other voltages on request

Coil connectors (type 40-1836) _____
DC: DG = DIN connector to EN 175301-803
DK = KOSTAL threaded connection M27x1
DL = 2 flying leads, 457 mm long, 0.75 mm²
DN = Deutsch connector, 2-pole, axial
DT = AMP Junior Timer, 2-pole, radial
AC: AG = DIN connector to EN 175301-803
Other connectors on request

Standard models

Model code	Part No.
WK08A-01-C-N-24DG	3022017
WK08A-01-C-N-230AG	3043866
Other models on request	

* Standard in-line bodies

Code	Part No.	Material	Ports	Pressure
FH084-SB3	563383	Steel, zinc-plated	G3/8	420 bar
FH084-AB3	3011407	Aluminium, clear anodized	G3/8	210 bar
Other housings on request				

Seal kits

Code	Material	Part No.
FS084-N SEAL KIT	NBR	3071272
FS084-V SEAL KIT	FKM	3071273

PERFORMANCE

Measured at $v = 34 \text{ mm}^2/\text{s}$, $T_{\text{oil}} = 46^\circ\text{C}$

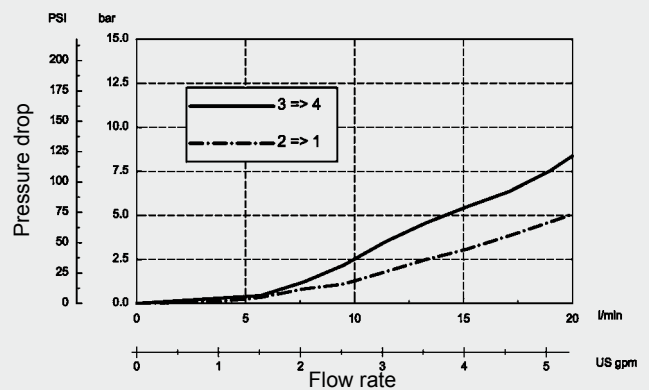

NOTE

The information in this brochure relates to the operating conditions and applications described. For applications or operating conditions not described, please contact the relevant technical department.
Subject to technical modifications.

HYDAC Fluidtechnik GmbH
Justus-von-Liebig-Str.
D-66280 Sulzbach/Saar
Tel: 0 68 97 /509-01
Fax: 0 68 97 /509-598
E-Mail: flutec@hydac.com

CAVITY

FC08-4

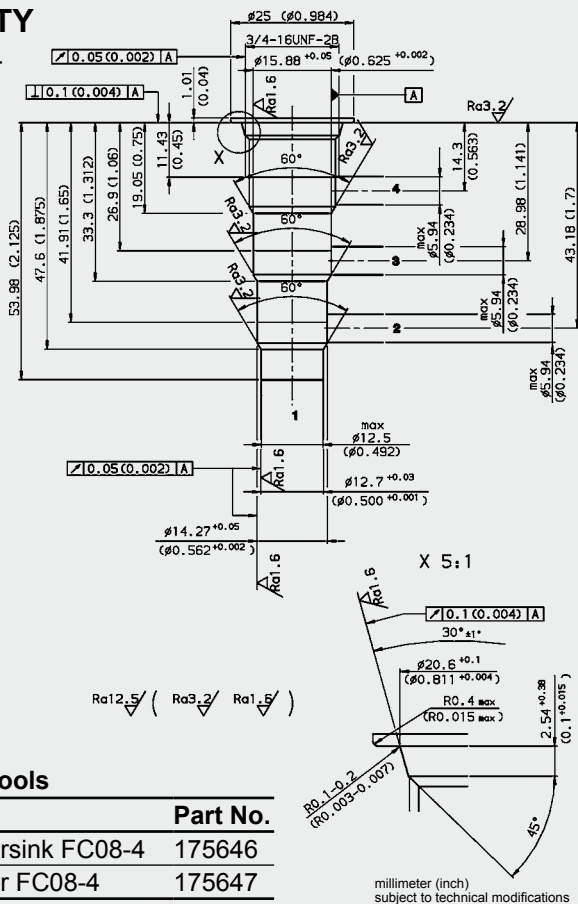

Form tools

Tool	Part No.
Countersink FC08-4	175646
Reamer FC08-4	175647