

4/2 Solenoid Directional Valve Spool Type, Direct-Acting SAE-08 Cartridge – 350 bar WK08X-01

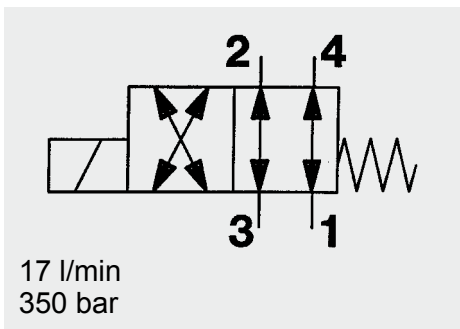

FUNCTION

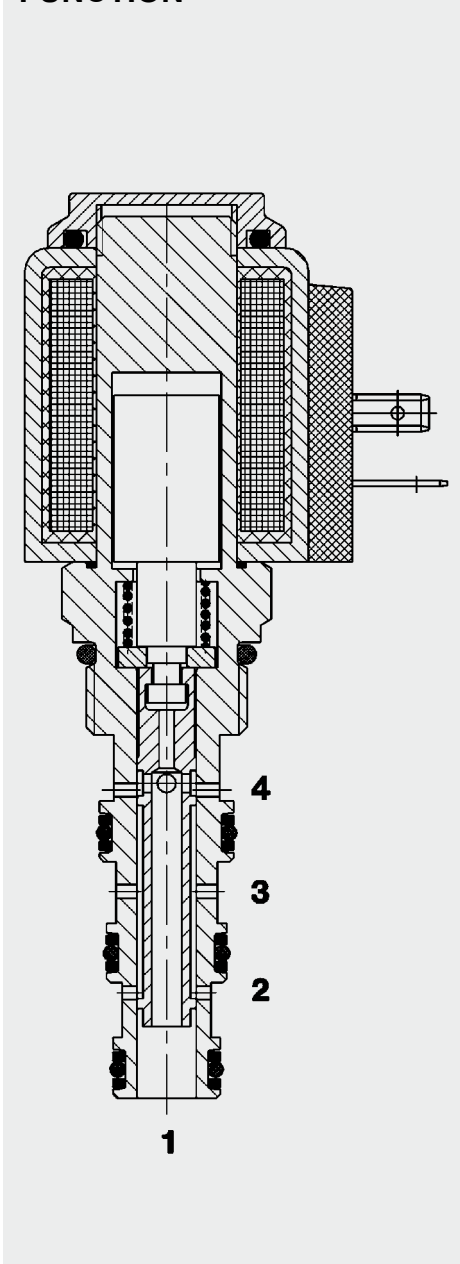

When de-energized, the valve allows flow from port 3 to 2 or from 2 to 3 and from port 4 to 1 or 1 to 4. When the solenoid coil is energized, there is free flow through the valve from port 3 to 4 or from 4 to 3 and also from port 2 to 1 or from 1 to 2.

FEATURES

- External surfaces zinc-plated and corrosion-proof
- Hardened and ground internal valve components to ensure minimal wear and extended service life
- Coil seals protect the solenoid system
- Wide variety of connectors available
- Excellent switching performance by high power HYDAC solenoid
- Low pressure drop due to CFD optimized flow path

SPECIFICATIONS

Operating pressure:	max. 350 bar	
Nominal flow:	max. 17 l/min Consult HYDAC for flow ratings above 207 bar	
Internal leakage:	90 cm ³ /min at 250 bar and 34 mm ² /s	
Media operating temperature range:	min. -20 °C to max. +100 °C	
Ambient temperature range:	min. -30 °C to max. +60 °C	
Operating fluid:	Hydraulic oil to DIN 51524 Part 1 and 2	
Viscosity range:	min. 7.4 mm ² /s to max. 420 mm ² /s	
Filtration:	Class 21/19/16 according to ISO 4406 or cleaner	
MTTF _d :	150 years (see "Conditions and instructions for valves" in brochure 5.300)	
Installation:	No orientation restrictions	
Materials:	Valve body:	free-cutting steel
	Spool:	hardened and ground steel
	Seals:	NBR (standard) FKM (optional, media temperature range -20 °C to +120 °C)
	Back-up rings:	PTFE
	Coil:	steel / polyamide
Cavity:	FC08-4	
Weight:	Valve complete	0.38 kg
	Coil only	0.19 kg

Electrical data:

Type of voltage:	DC solenoid, AC voltage is rectified using a bridge rectifier built into the coil	
Current draw at 20 °C:	1.5 A at 12 V DC 0.8 A at 24 V DC	
Voltage tolerance:	± 15% of the nominal voltage	
Coil duty rating:	Continuous up to max. 115% of the nominal voltage at 60 °C ambient temperature	
Coil type:	Coil...-40-1836	

