

FUNCTION

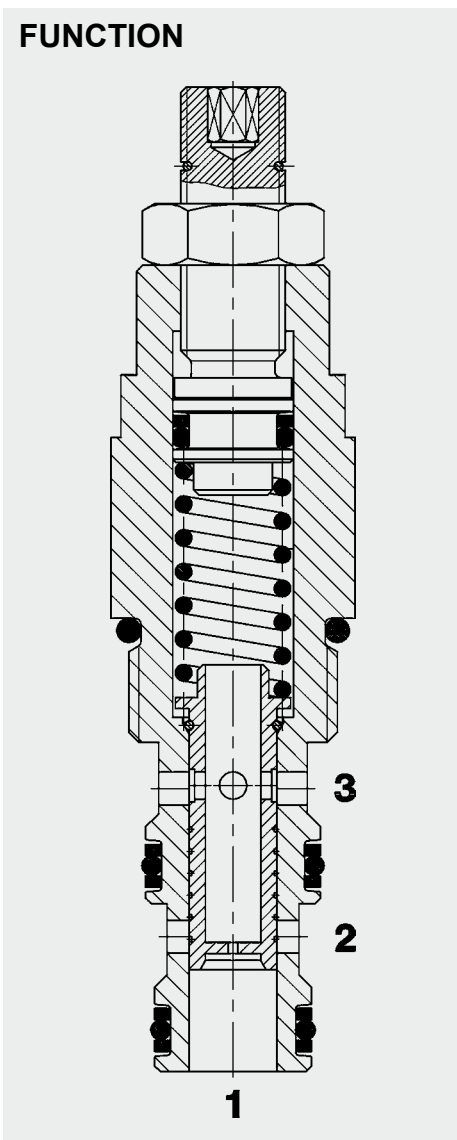

The flow regulator SRP08 is a 3-way spool-type flow regulating valve, with a measuring orifice for controlling flow rate independently of the pressure. The excess flow is made available on the bypass line at port 2. If port 2 is closed the valve acts as a 2-way restrictive flow regulator. If port 3 is closed the valve will stay closed because there is no pressure differential over the piston.

3-Way Flow Regulator, Pressure Compensated Priority Style, SAE-8 Cartridge – 350 bar SRP08

FEATURES

- Excellent stability throughout flow range
- External surfaces zinc-plated and corrosion proof
- Hardened and ground internal valve components to ensure minimal wear and extended service life
- Low pressure drop by CFD optimized flow path
- Optional flow ranges up to 30 l/min
- Flow rate can be adjusted within a limited range
- Excess flow at the bypass can be used to supply other consumers

SPECIFICATIONS

Operating pressure:	max. 350 bar
Inlet flow Q1:	max. 50 l/min
Flow rate Q3:	max. 30 l/min
Flow ranges and accuracy:	1.3 – 1.8 l/min 1.6 – 2.5 l/min 2.0 – 3.7 l/min 3.5 – 6.5 l/min 6.0 – 12.5 l/min 8.8 – 20.8 l/min 13.5 – 30.0 l/min
Media operating temperature range:	min. -30 °C to max. +100 °C
Operating fluid:	Hydraulic oil to DIN 51524 Part 1 and 2
Viscosity range:	min. 7.4 mm ² /s to max. 420 mm ² /s
Filtration:	Class 21/19/16 according to ISO 4406 or cleaner
MTTF _d :	150 years (see "Conditions and instructions for valves" in brochure 5.300)
Installation:	No orientation restrictions
Materials:	Valve body: free-cutting steel Piston: hardened and ground steel Seals: NBR (standard) FKM (optional, media temperature range -20 °C to +120 °C) Back-up rings: PTFE
Cavity:	FC08-3
Weight:	0.126 kg

DIMENSIONS

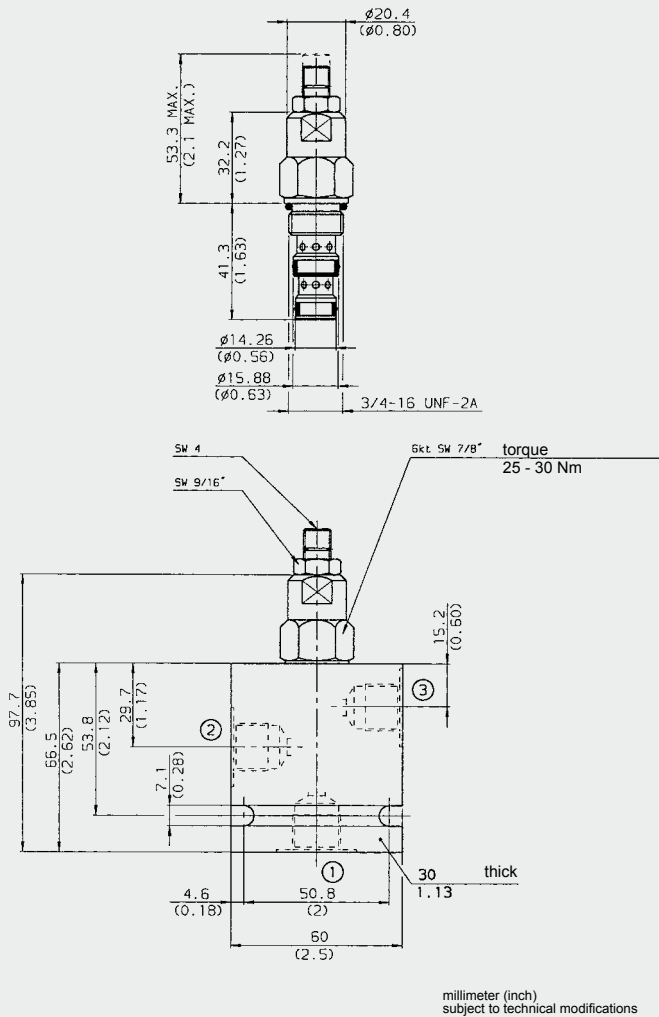

MODEL CODE

SRP08-01 - C - N - 1.0 V 0.8

Basic model _____
Flow regulator, UNF

Body and ports* _____
C = cartridge only
SB3 = G3/8 ports, steel body
AB3 = G3/8 ports, aluminium body

Seals _____
N = NBR
V = FKM

Flow rate code and flow range _____
0.4 = 1.3 – 1.8 l/min
0.5 = 1.6 – 2.5 l/min
0.9 = 2.0 – 3.7 l/min
1.6 = 3.5 – 6.5 l/min
3.0 = 6.0 – 12.5 l/min
5.5 = 8.8 – 20.8 l/min
7.9 = 13.5 – 30.0 l/min

Type of adjustment _____
V = Allen head (hex. 5/32")
H = knob adjustment
Other adjustment types on request

Setting _____
No details = set to lowest value of flow range

Standard models

Model code	Part No.
SRP08-01-C-N-0.5V	3020780
SRP08-01-C-N-0.9V	3020781
SRP08-01-C-N-3.0V	3020823
SRP08-01-C-N-5.5V	3020824

Other models on request

Standard in-line bodies

Code	Part No.	Material	Ports	Pressure
FH083-SB3	560922	Steel, zinc-plated	G 3/8	420 bar
FH083-AB3	3011427	Aluminium, clear anodized	G3/8	210 bar

Other housings on request

Seal kits

Code	Material	Part No.
FH083-N	NBR	3054795
FH083-V	FKM	2591059

CAVITY

FC08-03

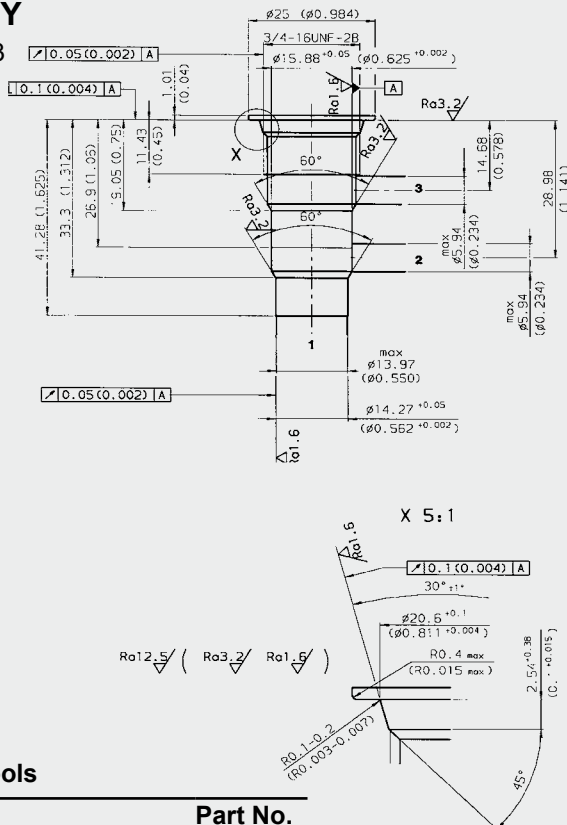

Form tools

Tool	Part No.
Countersink FC08-3	175644
Reamer FC08-3	175645

PERFORMANCE

Measured at $v = 34 \text{ mm}^2/\text{s}$, $T_{\text{oil}} = 46 \text{ }^\circ\text{C}$

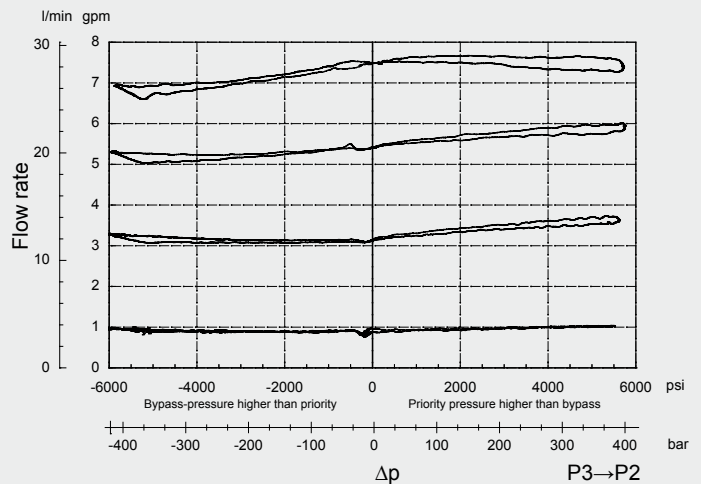

NOTE

The information in this brochure relates to the operating conditions and applications described. For applications or operating conditions not described, please contact the relevant technical department.
Subject to technical modifications.

HYDAC Fluidtechnik GmbH
Justus-von-Liebig-Str.
D-66280 Sulzbach/Saar
Tel: 0 68 97 /509-01
Fax: 0 68 97 /509-598
E-Mail: flutec@hydac.com