

FUNCTION

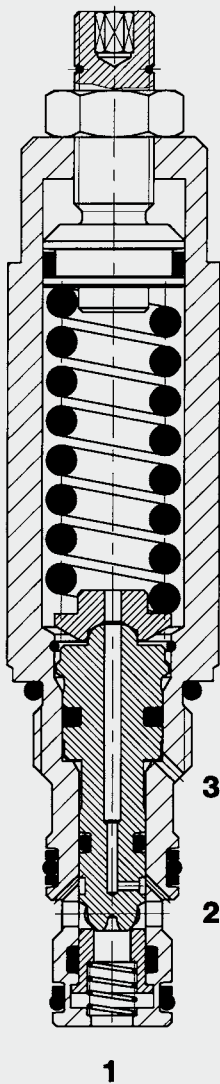

The counterbalance valve RS08 is a direct-acting poppet valve. Its function is to control the speed of a consumer according to the inlet flow. It also prevents the consumer from overrunning if there are retracting loads and ensures smooth action in consumers. In load-holding applications, it can be used as a hose-break valve.

Counterbalance Valve Poppet Type, Direct-Acting SAE-08 Cartridge – 350 bar

UNF

RS08-01

FEATURES

- External surfaces zinc-plated and corrosion-proof
- Excellent stability throughout the entire flow range
- Adjustable throughout flow range
- Max. stroke limiter
- Hardened and ground internal valve components to ensure minimal wear and extended service life
- Sealing between port 2 and port 3 prevents leakage between the ports
- Optional spring ranges up to 350 bar
- Quick response

SPECIFICATIONS

Operating pressure:	max. 350 bar
Nominal flow:	max. 38 l/min
Setting pressure:	up to 350 bar
Cracking pressure:	3 bar
Internal leakage:	max. 0.25 cm ³ /min at 80% nominal pressure
Pilot ratio:	3 = 3:1 4 = 4:1
Media operating temperature range:	min. -30 °C to max. +100 °C
Ambient temperature range:	min. -30 °C to max. +100 °C
Operating fluid:	Hydraulic oil to DIN 51524 Part 1 and 2
Viscosity range:	min. 7.4 mm ² /s to max. 420 mm ² /s
Filtration:	Class 21/19/16 according to ISO 4406 or cleaner
MTTF _d :	150 years (see "Conditions and instructions for valves" in brochure 5.300)
Installation:	No orientation restrictions
Materials:	Valve body: free-cutting steel Poppet: hardened and ground steel Seals: NBR (standard) FKM (optional, media temperature range -20 °C to +120 °C) Back-up rings: PTFE
Cavity:	FC08-3
Weight:	0.27 kg

MODEL CODE

RS08-01 - C - N - 3 500 V 300

Basic model

Counterbalance valve UNF

Body and ports*

C = cartridge only

SB3 = G3/8 ports, steel body

AB3 = G3/8 ports, aluminium body

Seals

N = NBR (standard)

V = FKM

Pilot ratio

3 = 3:1

4 = 4:1

Pressure setting range

500 = 350 bar (5000 psi)

Type of adjustment

V = Allen head (hex. 5/32")

H = Knob adjustment

F = Factory preset, non adjustable

Cracking pressure setting

No details = no setting, spring relaxed

300 = 210 bar (3000 psi)

Customer-specific opening pressure on request

Standard models

Model code	Part No.
RS08-01-C-N-3-500V	562797
RS08-01-C-N-4-500V	562798

*Standard in-line bodies

Code	Part No.	Material	Ports	Pressure
FH083-SB3	560922	Steel, zinc-plated	G3/8	420 bar
FH083-AB3	3011427	Aluminium, anodized	G3/8	210 bar

Seal kits

Code	Material	Part No.
FS083-N SEAL KIT	NBR	3054795
FS083-V SEAL KIT	FKM	2591059

PERFORMANCE

Measured at $v = 34 \text{ mm}^2/\text{s}$, $T_{\text{oil}} = 46 \text{ }^\circ\text{C}$

phi = 3:1

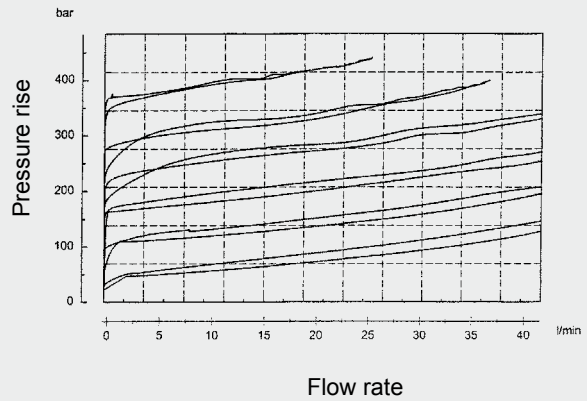

Measured at $v = 34 \text{ mm}^2/\text{s}$, $T_{\text{oil}} = 46 \text{ }^\circ\text{C}$

phi = 4:1

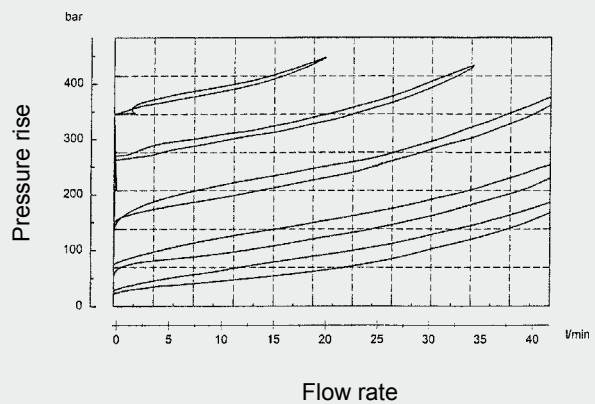

Measured at $v = 34 \text{ mm}^2/\text{s}$, $T_{\text{oil}} = 46 \text{ }^\circ\text{C}$

phi = 3:1

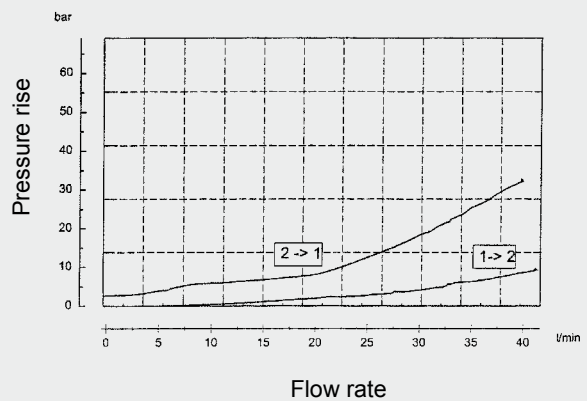

Measured at $v = 34 \text{ mm}^2/\text{s}$, $T_{\text{oil}} = 46 \text{ }^\circ\text{C}$

phi = 4:1

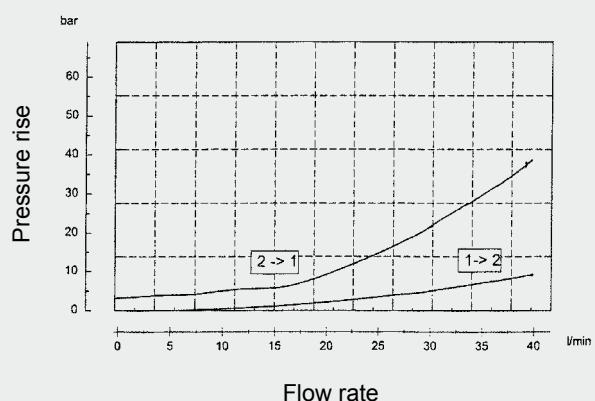

DIMENSIONS

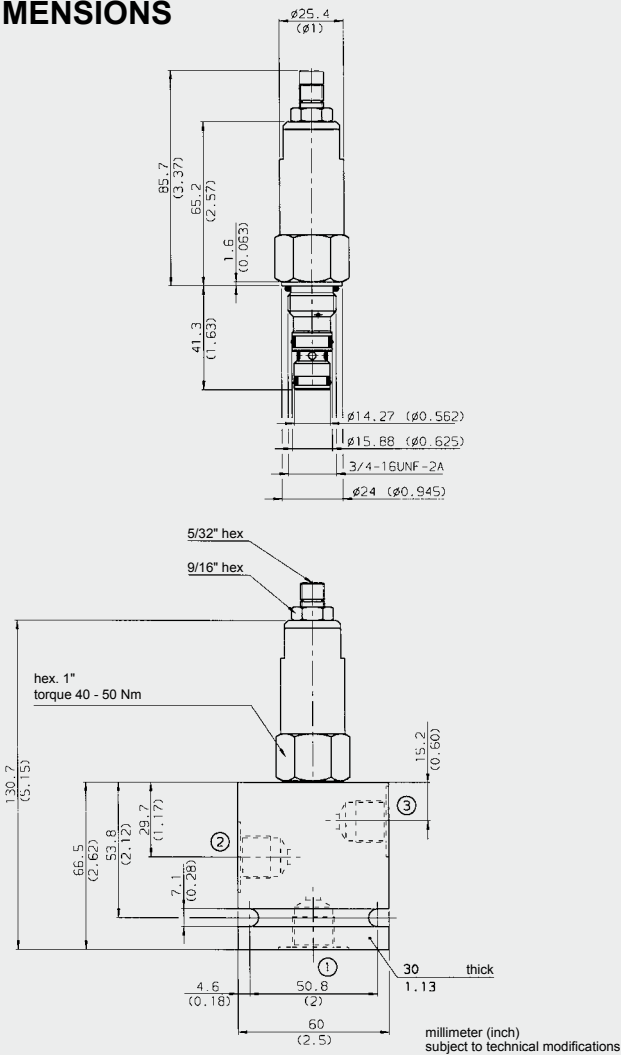

To raise a load, flow is permitted from pump port 2 to consumer port 1 via the built-in check valve. To hold the load, the check valve piston is pressed against its seat by the load pressure at port 1 and seals leakage-free (control port 3 must be at zero pressure!).

To lower the load, pressure is applied to control port 3 which controls the valve. Flow is now permitted from port 1 to port 2. The load cannot therefore overrun because the load flow rate is controlled at the metering edge of the control piston according to the consumer's inlet pressure.

An additional restriction of the load pressure is provided in that the consumer pressure (load pressure) at port 1 acts on a control piston within the valve and therefore against the force of the adjustment spring. When the spring tension is exceeded, the control piston moves away from the check valve piston, and this opens the flow path from port 1 to port 2 – the resulting flow limits the load pressure to the pre-set value.

Speed is controlled when lowering the consumer. For overrunning loads, the valve must be installed in the return line of the consumer.

CAVITY

FC08-3

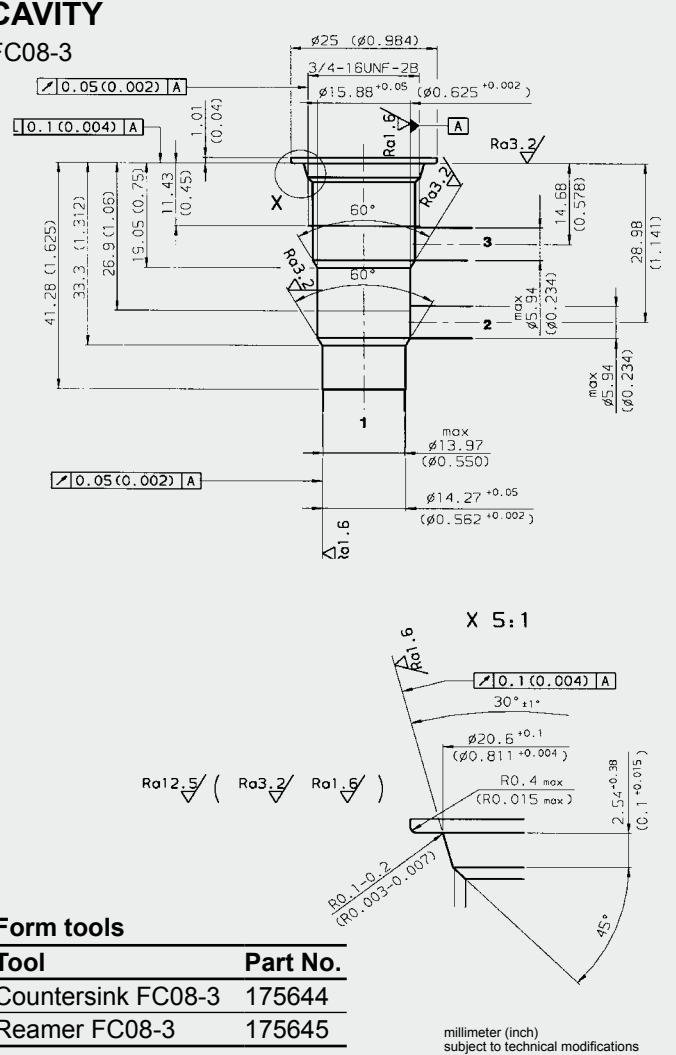

Form tools

Tool	Part No.
Countersink FC08-3	175644
Reamer FC08-3	175645

Note

The information in this brochure relates to the operating conditions and applications described. For applications or operating conditions not described, please contact the relevant technical department.
Subject to technical modifications.

HYDAC Fluidtechnik GmbH

Justus-von-Liebig-Str.
D-66280 Sulzbach/Saar
Tel: 0 68 97 /509-01
Fax: 0 68 97 /509-598
E-Mail: flutec@hydac.com

