

Up to 19 l/min
Up to 250 bar

FUNCTION

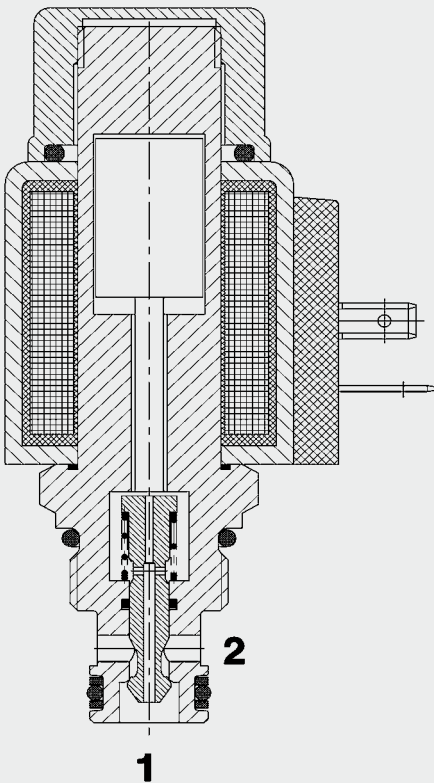

2/2 Solenoid Directional Valve Poppet Type, Direct Acting Normally Closed Metric Cartridge – 250 bar

WSM06020W-01

FEATURES

- Excellent switching performance by high power HYDAC solenoid
- Hardened and ground control piston to ensure minimal wear and extended service life
- Low pressure drop due to CFD optimized flow path
- Coil seals protect the solenoid system
- External surfaces zinc-plated and corrosion-proof
- Compact design enables space-saving installation in connection housings and control blocks

SPECIFICATIONS

Operating pressure:	max. 250 bar
Nominal flow:	max. 19 l/min
Internal leakage:	Leakage-free (max. 5 drops = 0,25 cm ³ /min at 350 bar)
Media operating temperature range:	min. -20 °C to max. +100 °C
Ambient temperature range:	min. -20 °C to max. +60 °C
Operating fluid:	Hydraulic oil to DIN 51524 Part 1 and 2
Viscosity range:	10 to 420 mm ² /s
Filtration:	Class 21/19/16 according to ISO 4406 or cleaner
MTTF _d :	150 years (see "Conditions and instructions for valves" in brochure 5.300)
Installation:	No orientation restrictions
Materials:	Valve body: free-cutting steel Poppet: hardened and ground steel Seals: NBR (standard) FKM (optional, media temperature range -20 °C to +120 °C) Back-up rings: PTFE Coil: steel / polyamide
Cavity:	06020
Weight:	Valve complete 0.33 kg Coil only 0.19 kg

Electrical data:

Type of voltage:	DC solenoid, AC voltage is rectified using a bridge rectifier built into the coil
Nominal voltage:	1.5 A at 12 V DC 0.8 A at 24 V DC
Voltage tolerance:	± 15% of the nominal voltage
Coil duty rating:	Continuous up to max. 115% of the nominal voltage at 60 °C ambient temperature
Response time:	Energized: approx. 35 ms De-energized: approx. 50 ms
Coil type:	Coil...-40-1836

When the solenoid coil is de-energized, the valve blocks flow in both directions.
When energized the valve allows flow in both directions.

DIMENSIONS

After loosening the mounting nut, the coil can be rotated through 360° and removed

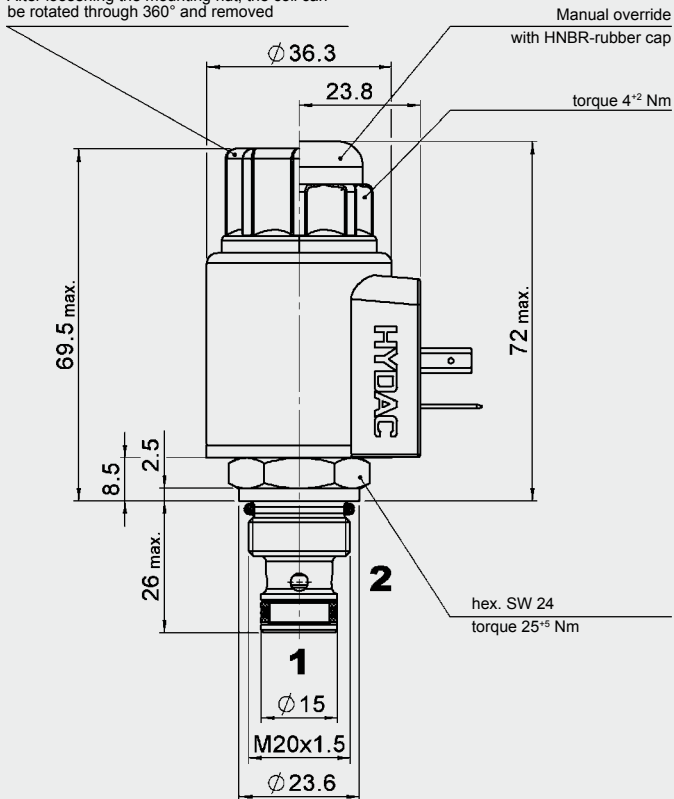

millimeter
subject to technical modifications

CAVITY:

06020

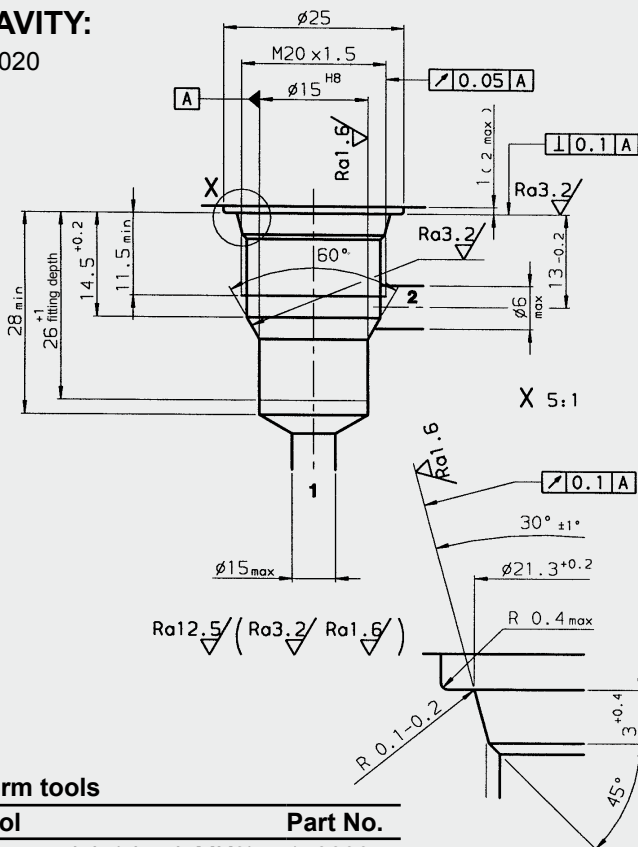

Form tools

Tool	Part No.
Countersink (shank MK3)	170033
Reamer (shank MK2)	1000768

millimeter
subject to technical modifications

MODEL CODE

WSM06020W - 01 M - C - N - 24 DG

Basic model _____
Directional poppet valve, metric

Type _____
01 = standard

Manual override _____
No details = without manual override
M = manual override

Body and ports* _____
C = cartridge only

Seals _____
N = NBR (standard)
V = FKM

Nominal voltage for actuating solenoid _____

DC voltages:

12 = 12 V DC
24 = 24 V DC

AC voltages (bridge rectifier built into the coil)

115 = 115 V AC
230 = 230 V AC

Other voltages on request

Coil connectors (type 40-1836) _____

DC: DG = DIN connector to EN175301-803
DT = AMP Junior Timer, 2-pole, radial
DK = Kostal threaded connection M27 x 1
DL = 2 flying leads 475 mm long, 0.75 mm²
DN = Deutsch connector, axial
AC: AG = DIN connector to EN175301-803

Other connectors on request

Standard models

Model code	Part No.
WSM06020W-01-C-N-24DG	3055971
WSM06020W-01-C-N-230AG	3055969

*Standard in-line bodies

Code	Part No.	Material	Ports	Pressure
R06020-01X-01	275266	Steel, zinc-plated	G 3/8	420 bar

Other housings on request

Seal kits

Code	Material	Part No.
SEAL KIT 06020	NBR	3119017
SEAL KIT 06020	FKM	3262477

PERFORMANCE

Measured at $v = 34 \text{ mm}^2/\text{s}$, $T_{\text{oil}} = 46 \text{ }^\circ\text{C}$

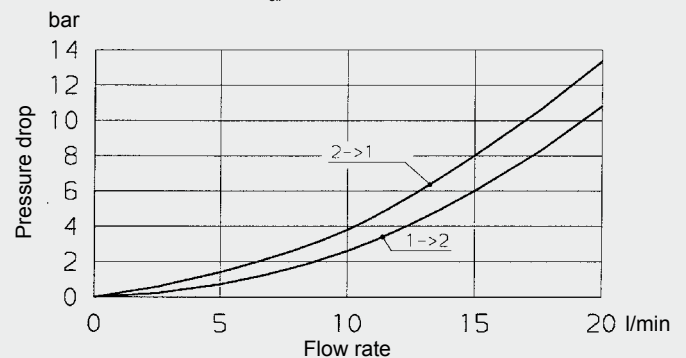

NOTE

The information in this brochure relates to the operating conditions and applications described. For applications or operating conditions not described, please contact the relevant technical department.
Subject to technical modifications.

HYDAC Fluidtechnik GmbH
Justus-von-Liebig-Str.
D-66280 Sulzbach/Saar
Tel: 0 68 97 /509-01
Fax: 0 68 97 /509-598
E-Mail: flutec@hydac.com