

FUNCTION

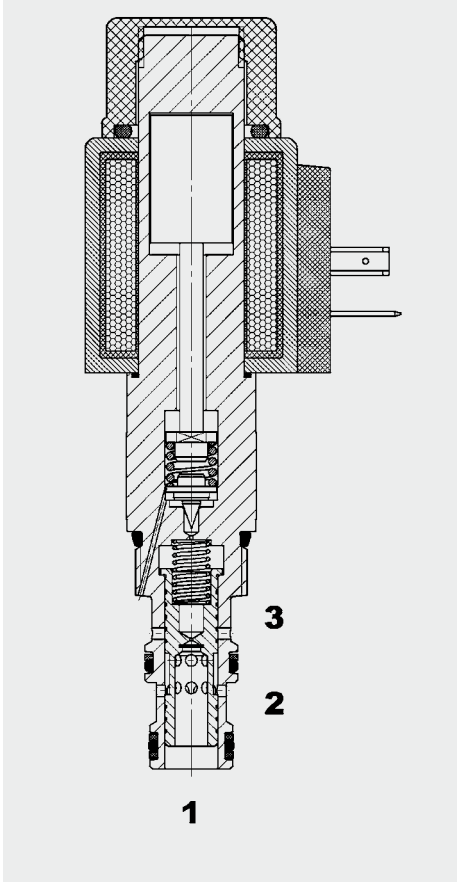

The proportional pressure reducing valve PDR08P is a pilot-operated 3-way spool-type valve, with relief included. If the pressure exceeds the setting defined by the electrical signal, the pilot-stage opens and oil flows from behind the main spool to the tank port 3. The resulting pressure differential causes the main spool to move against the reset-spring and allows oil to flow from port 2 to port 1. This continues until the system pressure is equal to the adjusted tension and the valve goes in control position again.

If the pressure at port 1 suddenly rises due to external force the valve is relieved to tank port 3 (maximum pressure relief).

Any pressure at port 3 is additive to the valve pressure setting.

3-Way Proportional Pressure Reducing Valve Spool Type, Pilot-Operated SAE-08 Cartridge – 350 bar

PDR08P-01

FEATURES

- External surfaces zinc-plated and corrosion-proof
- Hardened and ground internal valve components to ensure minimal wear and extended service life
- Coil seals protect the solenoid system
- Excellent stability throughout the entire flow range
- Excellent dynamic performance
- Low pressure drop due to CFD optimized flow path
- Screen protected metering orifice enhances safety

SPECIFICATIONS

Operating pressure:	max. 350 bar
Nominal flow:	max. 60 l/min
Operating pressure ranges:	up to 60 bar up to 230 bar up to 350 bar
Media operating temperature range:	min. -20 °C to max. +100 °C
Ambient temperature range:	min. -20 °C to max. +60 °C
Operating fluid:	Hydraulic oil to DIN 51524 Part 1 and 2
Viscosity range:	min. 7.4 mm ² /s to max. 420 mm ² /s
Filtration:	Class 18/16/13 to class 19/17/14 to ISO 4406 or cleaner
MTTF _d :	150 years (see "Conditions and instructions for valves" in brochure 5.300)
Installation:	No orientation restrictions
Materials:	Valve body: free-cutting steel Spool: hardened and ground steel Seals: NBR (standard) FKM (optional, media temperature range -20 °C to +120 °C) Back-up rings: PTFE Coil: steel / polyamide
Cavity:	FC08-3
Weight:	Valve complete 0.45 kg Coil only 0.23 kg

Electronic data:

Control currents:	1050 mA, 8.8 Ω (24 Volt) 2100 mA, 2.2 Ω (12 Volt)
Internal leakage:	less than 0.5 l/min at 350 bar
Dither frequency:	approx. 160 Hz - 250 Hz
Response time:	energized: approx. 60 ms de-energized: approx. 40 ms
Hysteresis with dither:	2-4% of I _{nom}
Repeatability:	2-4% of I _{nom}
Hysteresis:	≤ 2% of I _{nom}
Response sensitivity:	≤ 1 % of I _{nom}
Coil type:	Coil...-40-1836

The PDR08P can also be supplied with an emergency pressure adjustment (version -01M). This allows a manual pressure adjustment of the valve if the electrical signal is interrupted. This adjustment should be used only in the case of electrical failure since the manual setting would be additive to the electrical setting and the system could be damaged when power is restored.

DIMENSIONS

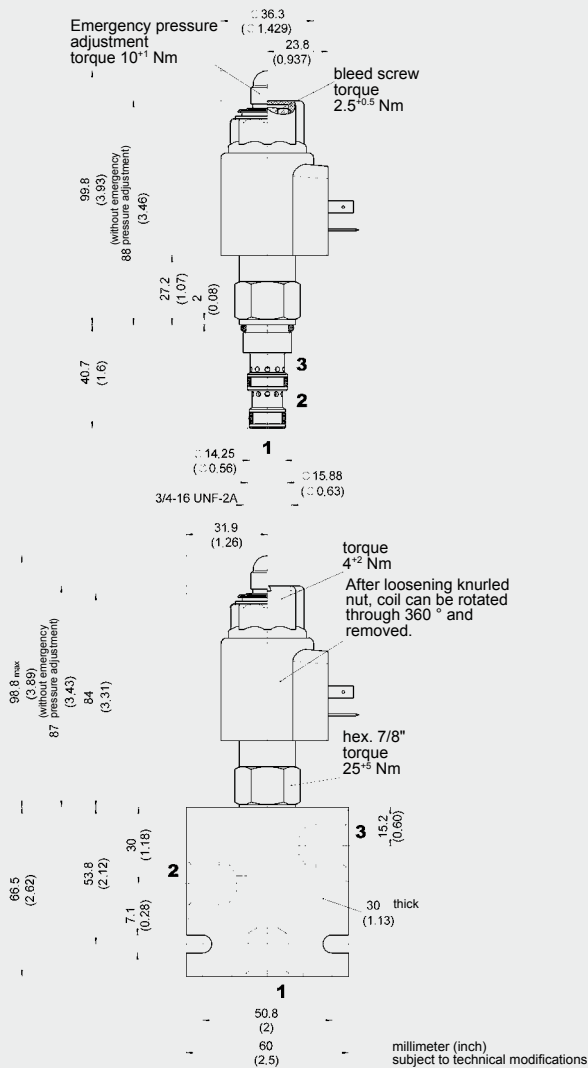

MODEL CODE

PDR08P-01 M - C - N - 330 - 24 PG - 8.8

Basic model
Directional spool valve, UNF

Manual override
no details = without manual override
M = manual override

Body and ports*
C = cartridge only
SB3 = G3/8 ports, steel body
AB3 = G3/8 ports, aluminium body

Seals
N = NBR (standard)
V = FKM

Pressure range
87 = up to 60 bar (870 PSI)
330 = up to 230 bar (3300 PSI)
500 = up to 350 bar (5000 PSI)

Coil voltage
12 = 12 V DC
24 = 24 V DC

Coil connectors (type 40-1836)
DC: PG = DIN connector to EN175301-803
PU = AMP Junior Timer, 2-pole, axial
PL = 2 flying leads, 457 mm long; 0.75 mm²
PN = Deutsch connector, 2-pole, axial, DT04-22P-EF 04

Other connectors on request

Coil resistance
2.2 = 2.2 Ω (12 V)
8.8 = 8.8 Ω (24 V)

Standard models

Model code	Part No.
PDR08P-01-C-N-87-12PG-2.2	3147475
PDR08P-01-C-N-330-12PG-2.2	3147476
PDR08P-01-C-N-500-12PG-2.2	3147477
PDR08P-01-C-N-87-24PG-8.8	3147488
PDR08P-01-C-N-330-24PG-8.8	3147489
PDR08P-01-C-N-500-24PG-8.8	3147490

*Standard in-line bodies

Code	Part No.	Material	Ports	Pressure
FH083-SB3	560922	Steel, zinc-plated	G3/8	420 bar
FH083-AB3	3011427	Aluminium, anodized	G3/8	210 bar

Other bodies on request

Seal kits

Code	Material	Part No.
FS083-N SEAL KIT	NBR	3054795
FS083-V SEAL KIT	FKM	2591059

CAVITY:

FC08-3

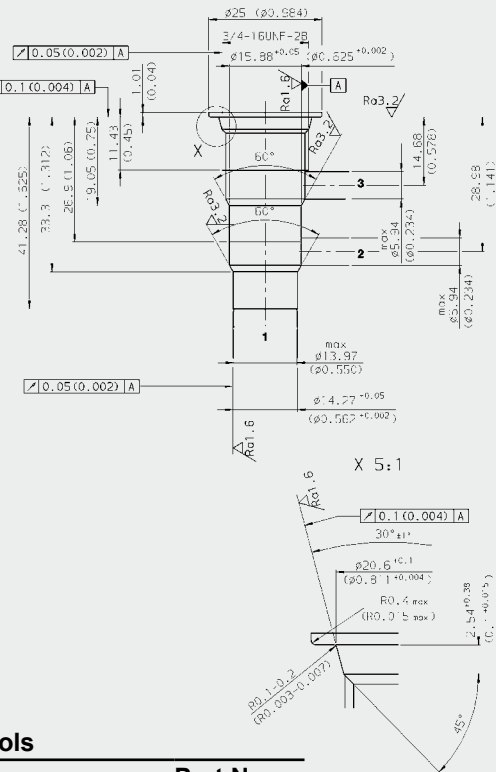

Form tools

Tool	Part No.
Countersink FC08-3	175644
Reamer FC08-3	175645

millimeter (inch)
subject to technical modifications

PERFORMANCE

Measured at $v = 34 \text{ mm}^2/\text{s}$, $T_{\text{oil}} = 46 \text{ }^\circ\text{C}$

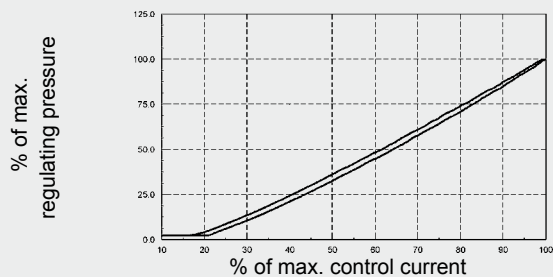

Measured at $v = 34 \text{ mm}^2/\text{s}$, $T_{\text{oil}} = 46 \text{ }^\circ\text{C}$

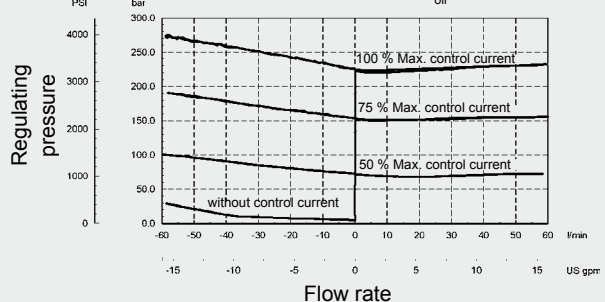

NOTE

The information in this brochure relates to the operating conditions and applications described. For applications or operating conditions not described, please contact the relevant technical department.
Subject to technical modifications.

HYDAC Fluidtechnik GmbH
Justus-von-Liebig-Str.
D-66280 Sulzbach/Saar
Tel: 0 68 97 /509-01
Fax: 0 68 97 /509-598
E-Mail: flutec@hydac.com