



FluidAqua Mobil FAM 5

Description

The FluidAqua Mobil FAM 5 is designed for dewatering, degassing and filtering hydraulic and lubrication fluids.

It operates on the principle of vacuum dewatering to eliminate free and dissolved water as well as free and dissolved gases. By using HYDAC Dimicron filter technology which has a high contamination retention capacity and filtration efficiency, the FAM 5 is extremely cost effective.

Its compact and mobile design makes it ideally suited for service work. The version designed for permanent installation provides continuous protection for applications where operating fluids require optimal conditioning, where valuable bio-oils or fire-resistant operating fluids are used, or where water frequently gets into the system.

Special features

- Small, compact and easy-to-use unit for prompt deployment during service calls or emergencies
- Reliable and convenient for fixed and permanent use due to extensive monitoring functions
- Optional integrated heater to increase dewatering performance, especially for cold or high viscosity oils
- Optional integrated water content and particle measurement technology with continuous display of the measurements and storage of the values
- Very low residual water content, gas content and particle contamination result in longer oil change intervals, improved life expectancy of components, higher machine availability and as a result, a reduction in the Life Cycle Cost (LCC)

Technical specifications

Flow rate at 50 Hz	≈ 5 l/min
Permitted fluids**	Fluids compatible with NBR seals: <ul style="list-style-type: none"> • Mineral oils to DIN 50524 • Gear oils to DIN 51517, 51524 Operating fluids compatible with FKM (FPM, Viton®) seals: <ul style="list-style-type: none"> • Synthetic esters (HEES) DIN 51524/2 • Vegetable oils (HETG, HTG) • HFD fluids (not for pure phosphate esters which require EPDM seals)
Sealing material	NBR or FKM (FPM, Viton®) see model code "Operating fluid"
Filter size of fluid filter	OLF 5
Filter element for fluid filter (xxx = filtration rating)	N5DMxxx Filter element must be ordered separately, see table "Filter elements for fluid filters".
Clogging indicator	Differential pressure switch with cut-off function when filter is clogged
Type of vacuum pump	Rotary vane vacuum pump
Pump type for filling & draining	Gear pump
Operating pressure	0 ... 8 bar / 0 ... 116 psi
Permitted pressure at suction port (without suction hose)	-0.2 ... +1 bar / -2.9 ... 14.5 psi
Permitted operating viscosity range**	15 ... 350 mm ² /s (without integrated heater)
Permitted viscosity range for particle measurement	15 ... 550 mm ² /s (with integrated heater)
Permitted viscosity range for particle measurement	15 ... 200 mm ² /s - with ACS measuring equipment
Fluid temperature range**	10 ... 80 °C / 50 ... 176 °F
Ambient temperature **	0 ... 40 °C / 32 ... 104 °F
Storage temperature range**	0 ... 40 °C / 32 ... 104 °F
Relative ambient humidity **	maximum 90%, non-condensing
Electrical power consumption (without heater) / required external fuse*	≈ 1 kW / 16 A for circuit breakers with trip characteristics type C
Heating output (optional)	max. 2.4 kW (depending on the nominal voltage, see model code)
Protection class	IP 54
Length of power cable / plug	10 m / CEE (depending on the nominal voltage, see model code)
Length of connection hoses	5 m (mobile version only)
Material of hoses	see model code
Hydraulic connections	see table "Connection summary"
Weight when empty	≈ 120 kg
Achievable residual water content	< 100 ppm - Hydraulic and lube oils < 50 ppm - Turbine oils (ISO VG 32/46) < 10 ppm - Transformer oils ***

* Maximum specifications given, depends on equipment

** For other fluids, viscosities or temperature ranges, please contact us

*** Units are not suitable for "Online" and "Onload" operation (transformer in operation and connected to grid).

Order details

FAM - 5 - M - 2 - A - 05 - R - H - B - ACS - 00 - V

Basic model

FAM = FluidAqua Mobil

Size

5 = ~ 5 l/min

Operating fluid

M = Mineral oil - NBR seals, NBR hoses, tested with mineral oil*

I = Insulating oil - NBR seals, NBR hoses, tested with insulating oil (e.g. Shell Diala)* / **

X = HFD-R fluids - FKM (FPM, Viton®) seals, UPE/PE-PA hoses, tested with HFD-R fluid (e.g. Fyrquel)*

B = Biodegradable (ester-based) - FKM (FPM, Viton®) seals, NBR hoses, tested with biodegradable operating fluid based on esters*

Mechanical type

1 = Stationary (with feet)

2 = Mobile (with castors and connection hoses)

Voltage / Frequency / Power supply

A = 400 V/50 Hz/3Ph+PE

B = 415 V/50 Hz/3Ph+PE

E = 220 V/60 Hz/3Ph+PE

H = 440 V/60 Hz/3Ph+PE¹⁾

K = 480 V/60 Hz/3Ph+PE¹⁾

M = 230 V/50 Hz/1Ph+PE

O = 460 V/60 Hz/3Ph+PE¹⁾

P = 230 V/60 Hz/1Ph+PE

S = 380 V/50 Hz/3Ph+PE

AD = 220 V/60 Hz/1Ph+PE

X = other voltage on request

Filter size of fine filter

05 = OLF5

Type of vacuum pump

R = Rotary vane vacuum pump

Heater

H = Heater

Z = Without Heater (for 200 ... 359 V = 1 kW, for 360 ... 690 V = 2.4 kW, heater only possible from 200 V)

Control concept

B = basic

Measuring equipment

Z = without

AD = AquaSensor 3000, with display directly on the sensor, without control function.

ACS = AquaSensor AS 1000 + ContaminationSensor CS 1000 + SensorMonitoring Unit. Display and storage of the measurements, without control function.

Modification number

00 = The latest version is always supplied.

Supplementary details

No details = standard

CSI = with GSM Wi-Fi module (HYDAC CSI-F-10)

V = FKM (FPM, Viton®) seals for "M" and "I" fluids

1) Supplied without connector

* Residues of test fluid will remain in the unit after testing

** Units not suitable for "Online" and "Onload" operation (transformer in operation and connected to grid)

Sizing

As a rough guide, the FluidAqua Mobil can be sized according to the tank volume of the system.

Tank volume in litres	Size
< 1,500	FAM 5
1,000 – 7,000	FAM 10/15 *
7,000 – 15,000	FAM 25 **
15,000 – 25,000	FAM 45 **
25,000 – 35,000	FAM 60 **
35,000 – 45,000	FAM 75 **
> 45,000	FAM 95 **

* see brochure no. 7.949 FluidAqua Mobil FAM 10

** see brochure no. 7.613 FluidAqua Mobil FAM 25/45/60/75/95 series

In general, it must however be noted that sizing will depend on the application, the fluid, the temperature of the fluid and the ambient temperature, the fluid quantity and the water ingress into the system. These have a great affect on the dewatering efficiency. Therefore the specifications can only serve as an indication.

	Dewatering rate	
Water content	↑	↑
Fluid temperature	↑	↑
Detergent additives	↑	↓
FAM flow rate	↑	↑

Heater

By using the built-in heater, the dewatering capacity can be increased, particularly in the case of high viscosity fluids or fluids at low temperatures.

If the temperature of the fluid is raised by 10 °C then the dewatering capacity increases by up to 50 %. The ideal temperature for dewatering is ≈ 50 ... 60 °C.

Generally speaking, for operating viscosities of between 350 ... 800 mm²/s the heater option must be selected and the heater must be used.

Instrumentation

If the water and particle measuring options (AquaSensor and ContaminationSensor) are included, it is possible to display the water content relative to the saturation point (saturation level, relative humidity), as well as the particle contamination and temperature of the fluid. The measured data is stored in the SensorMonitoring Unit with a date and time stamp and can be easily transferred using a USB memory stick.

Measurements

FAM Stationary

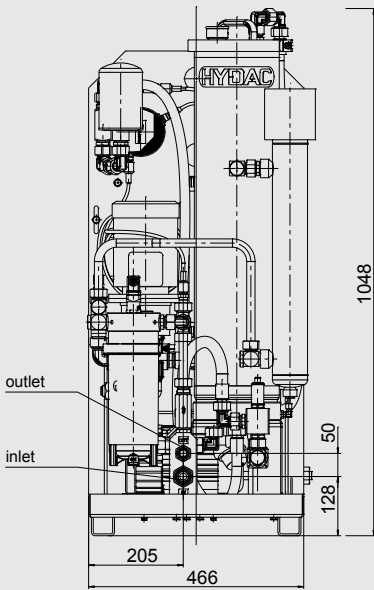

FAM Mobil

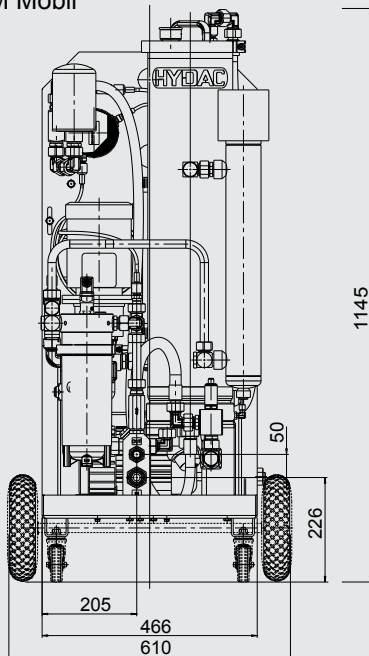

Type of vacuum pump

The vacuum pump used is an oil lubricated rotary vane pump.

The air discharged by the vacuum pump can, in addition to water, contain constituent elements of the operating fluid concerned, as well as any gases it contained.

Therefore, please ensure that the area in which the FAM is operated is adequately ventilated.

Hydraulic circuit

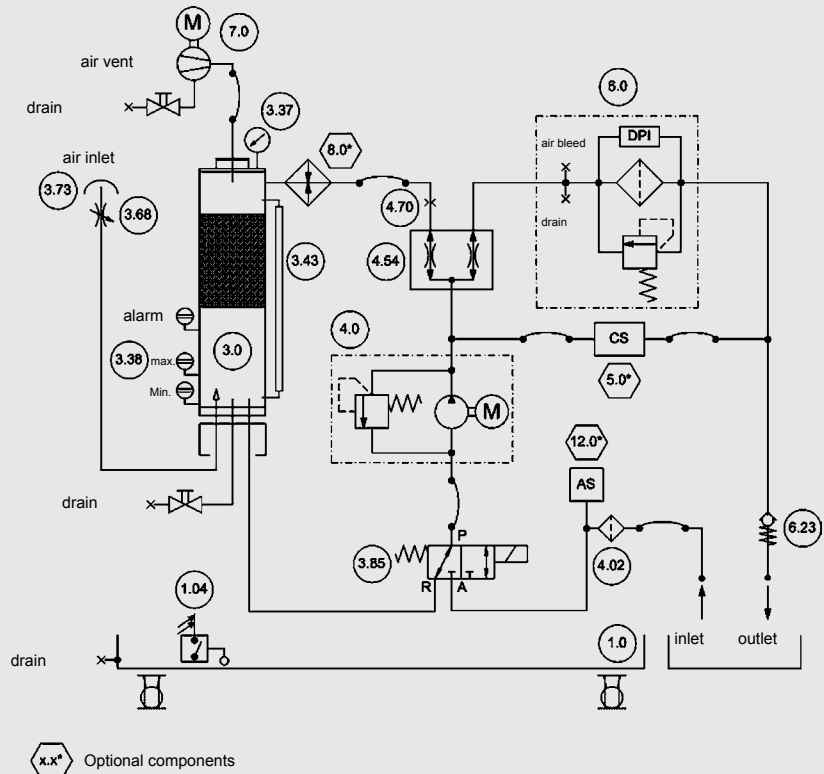

Item	Description
1.0	Drip tray
1.04	"Drip pan full" float switch
3.0	Vacuum column
3.38	Level sensor for vacuum column
3.68	Needle valve to regulate the necessary vacuum in the vacuum column
3.73	Breather filter
3.85	3/2 directional valve
4.0	Motor pump assembly
4.02	Suction screen
4.54	Flow divider
5.0	ContaminationSensor CS1000 (optional)
6.0	Fluid filter for elimination of solid particles, with differential pressure switch for filter monitoring
7.0	Vacuum pump
8.0	Heater (optional)
12.0	AquaSensor AS 1000 / AS 3000 (optional)

Fluid filter element

Please order the filter element for the fluid filter separately and install it before commissioning.

You will need one of the following filter elements for the fluid filter:

Type	Filtration rating	Seals	Part number
N5DM002	2 µm	FKM	349494
N5DM005	5 µm	FKM	3068101
N5DM010	10 µm	FKM	3102924
N5DM020	20 µm	FKM	3023508

Items supplied

- FluidAqua Mobil
- With suction and return hose (only on mobile version)
- 1 litre vacuum pump oil for initial filling of vacuum pump
- Control cabinet key
- Technical documentation:
 - Operating and Maintenance Manual
 - Electrical wiring diagram
 - Test certificate
 - CE declaration of conformity

Connection summary

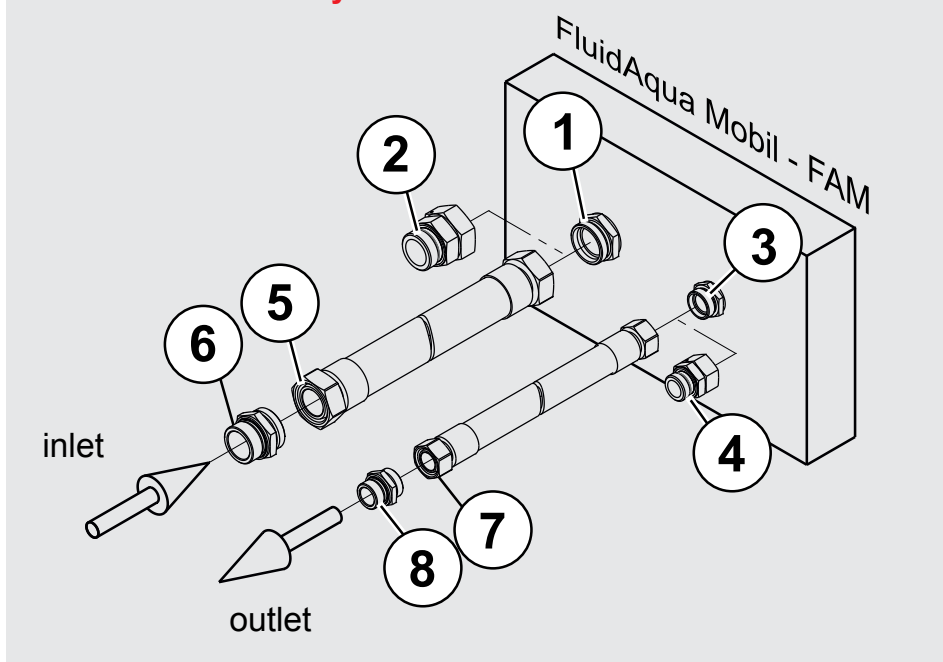

Item	FAM 5
1 - FAM inlet connector	28L / M36x2 (male thread)*
2 - Adapter	Adapter G1 A (male thread)**
3 - FAM outlet connector	18L / M26x1.5 (male thread)*
4 - Adapter	Adapter G ½ A (male thread)**
5 - Suction hose connection	28L / M36x2 (female thread)***
6 - Adapter	Adapter G1 A (male thread)**
7 - Pressure hose connection	18L / M26x1.5 (female thread)***
8 - Adapter	Adapter G ½ A (male thread)**

*) Connection Form D to ISO 8434-1 Series L (corresponds to ISO 12151, Form S, Series L)

**) Screw-in spigot to ISO 1179-2 (Form E)

***) Connection Form N to ISO 8434-4 Series L (corresponds to ISO 12151, Form SWS, Series L)

Items 1 ... 4 are supplied with the stationary FAM.

Items 1 ... 8 are supplied with the mobile FAM.

Accessories

Description	Material	Part number
Lance set for suction and return hose, consisting of: 2x lances Ø18 mm, length = 0.5 m	FKM	3685146

Note

The information in this brochure relates to the operating conditions and applications described.

For applications and operating conditions not described, please contact the relevant technical department.

Subject to technical modifications.

HYDAC FILTER SYSTEMS GMBH
 Industriegebiet
D-66280 Sulzbach / Saar
 Tel.: +49 (0) 6897/509-01
 Fax: +49 (0) 6897/509-846
 Internet: www.hydac.com
 E-Mail: filtersystems@hydac.com