



OXiStop OXS

Description

HYDAC's OXiStop is a tank solution for hydraulic systems with integrated, hydraulically driven degassing and dewatering unit.

An integrated membrane prevents direct contact with the ambient air. This means that the tank can be designed for the differential operating volume actually needed, reducing its size. The pump flow rate is not important for the tank design.

The fluid reaches a very low gas and water content.

Thanks to the membrane, which keeps the fluid "vacuum packed", it is also possible to install the OXiStop in extremely dusty or humid environments.

HYDAC offers three standard sizes for a differential operating volume up to 70 liters**. Additionally, customer specific solutions can be realised.

The OXiStop can be equipped with an optional return line filter, water / oil cooler as well as with the AquaSensor AS and the ContaminationSensor CS.

Advantages

- Oil volume reduction typically by a factor of 10
- Increased oil service life due to
 - 80 % less oxygen content and
 - reduced contamination ingress (solid, liquid, gaseous) because of closed system by membrane
- Reduced noise due to reduced cavitation by continuous degassing

Technical data

	OXS 30	OXS 45	OXS 70
Hydraulic data			
Differential operating volume **	up to 30 l	up to 45 l	up to 70 l
Total tank volume	110 l	135 l	185 l
Typical gas removal rate *	9 l/h		
Viscosity range	15 ... 300 mm ² /s		
Maximum fluid flow rate IN / OUT	900 l/min		
Fluid temperature range	10 ... 80 °C		
Ambient temperature range **	-20 ... 40 °C		
Filtration unit	OLF 5		
Filter element (filtration unit)	N5DM002		
Contamination retention capacity	200 g ISOMTD @ Δp = 2.5 bar		
Pump type, filtration unit	Vane pump		
Flow rate (filtration unit)	7.5 l/min		
Operating pressure filtration unit	10 bar		
Clogging indicator	Differential pressure indicator, visual (VM2BM.1)		
Connection A (IN / OUT)	2 x SAE 3" 3000PSI		
Connection B (IN / OUT)	2 x SAE 3" 3000PSI		
Electrical data (filtration unit)			
Electrical connection (motors)	See model code		
Electrical power consumption	370 ... 1,500 W, depending on type		
Protection class to DIN 40050	IP54		
General data			
Permissible fluids **	Mineral oils acc. to DIN 50524		
Sealing material **	NBR		
Membrane material **	PU		

* Typical values for ISO VG 46 @ 40 °C. The gas removal rate depends on the total gas content in the oil, the oil temperature and especially on the oil viscosity. With increasing viscosity, the gas removal rate is reduced.
** others on request

Typenschlüssel

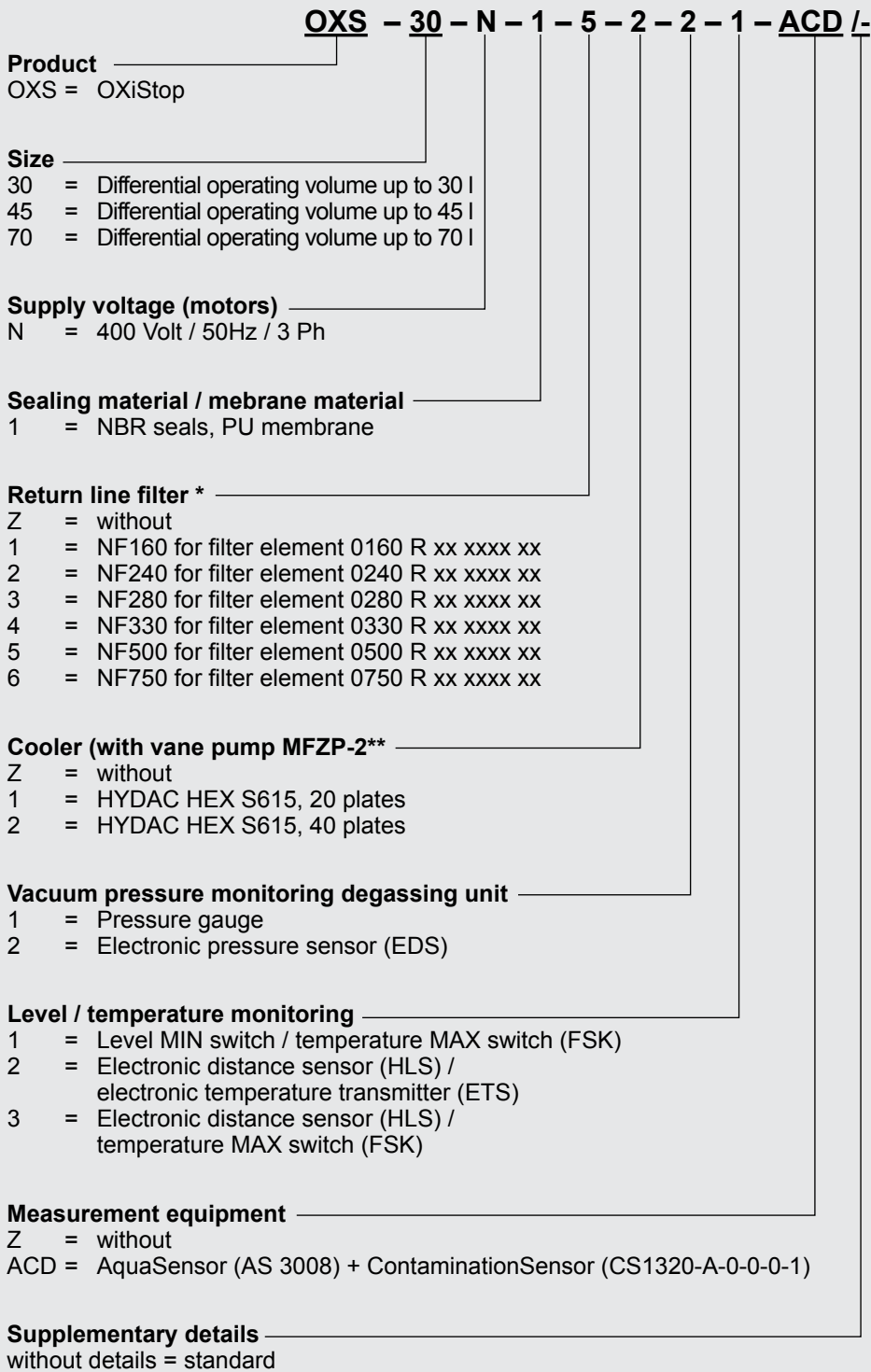

* The return line filter is supplied without filter element and clogging indicator. Please order separately. For information about design and for technical details see brochure 7.112 NF inline filter

** For information about design and for technical details of the cooler, see brochure 5.804 Plate-type heat exchanger

Sizing

The size required by the OXiStop can be calculated based on the actual volume differences of cylinders, accumulators, etc. that can occur in a system. In addition, it is necessary to consider a required volume for the thermal expansion of the oil and possible continuous oil losses. This volume can be doubled, as a safety margin.

Rule of thumb:

$$\frac{\text{Total volume difference of cylinders, etc} + \text{Temperature expansion volume}}{\text{Necessary volume}}$$

Differential operating volume OxiStop =
2 x necessary volume

Also, it is necessary to check whether the total oil volume in the system needs to be returned to the tank when maintenance work is carried out.

Scope of delivery

- OXiStop tank acc. to model code incl. tank with integrated membrane, MiniOx degassing unit, bypass flow filtration unit with optional ContaminationSensor CS 1000 and AquaSensor AS 3000, electronic or optical fluid level indicator, breather filter and piping of the individual components
- Operating and maintenance instructions for installed components
- OXiStop filling instructions

Accessories

- Filter elements for bypass flow filter OLF 5 (1 x N5DM002 already installed)

Part no.:	Designation
349494	N5DM002 (2 µm)
3068101	N5DM005 (5 µm)
3102924	N5DM010 (10 µm)
3023508	N5DM020 (20 µm)

- Filter elements for optional return line filter, see brochure 7.112 NF inline filter
- Electric clogging indicators, see brochure 7.112 NF inline filter
- Silicone heater for attaching to the surface of the tank, self-adhesive, approx. 500 W (on request)

Dimensions

	h	H
OXS 30	580	963
OXS 45	690	1073
OXS 70	905	1288

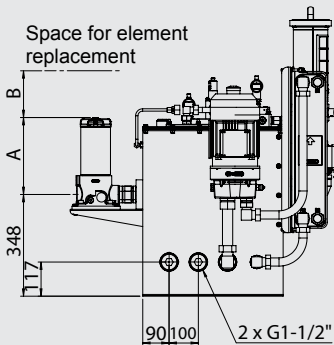
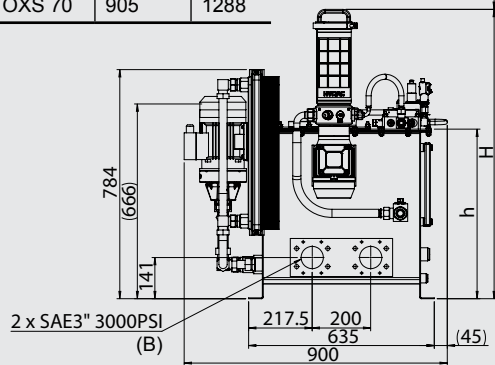

	A	B
NF160	205	160
NF240	264	220
NF280	360	400
NF330	294	170
NF500	375	250
NF750	726	600

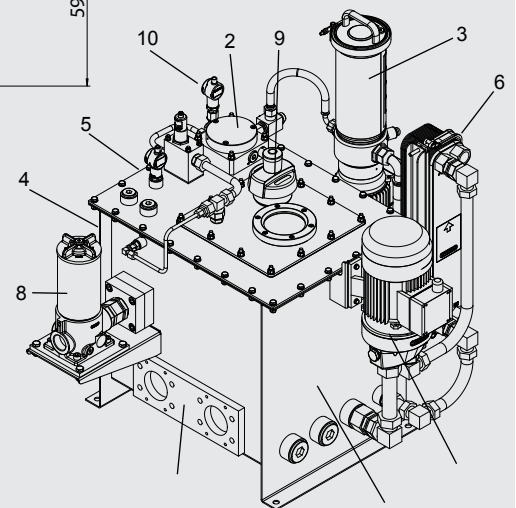
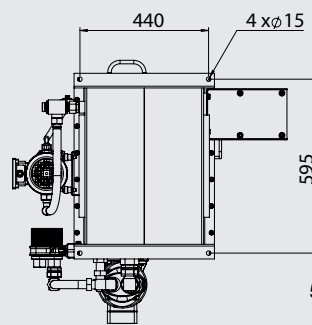
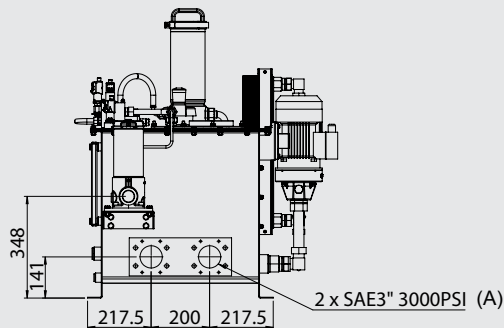

Hydraulic circuit

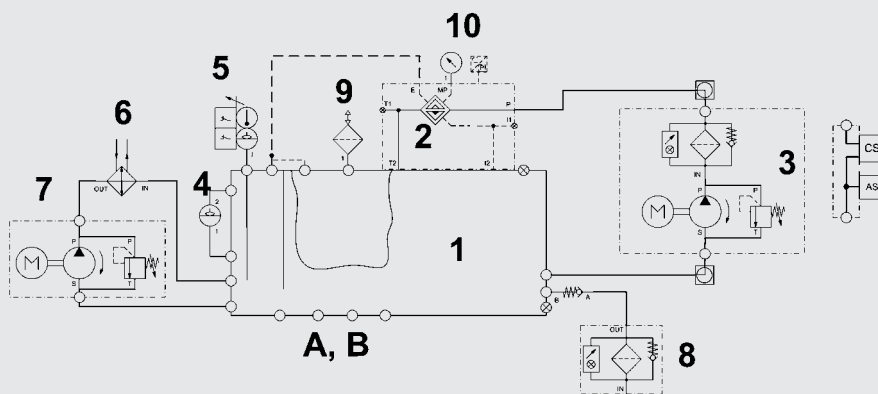

Position	Component
1	OxiStop tank with integrated tank membrane
2	MiniOX degasification and dewatering unit
3	OLF 5 offline filtration unit
4	Optical fluid level indicator with integrated level and temperature switch (optional)
5	Electronic fluid level indicator (optional)
6	Cooler HEXS615 (optional)
7	Cooler pump MFZP-2, approx. 60 l/min @ 50Hz (optional)
8	Return line filter NFxxx (optional)
9	Air filter
10	Vacuum pressure monitoring degassing unit
A, B	Hydraulic connectors

Note

The information in this brochure relates to the operating conditions and applications described.
For applications and operating conditions not described, please contact the relevant technical department.
Subject to technical modifications.

HYDAC FILTER SYSTEMS GMBH
Industriegebiet
D-66280 Sulzbach / Saar
Tel.: +49 (0) 6897/509-01
Fax: +49 (0) 6897/509-846
Internet: www.hydac.com
E-Mail: filtersystems@hydac.com