



Universal Compact I/O Expansion Module HY-TTC 30XS-H

Functional Safety
PL c

Description

The HY-TTC 30XS-H module was developed for distributed applications with increased functional safety.

Using the general standard, CANopen Safety to CIA DS 304 and CIA DS 401, the module can be easily controlled and integrated in the existing control system.

The HY-TTC 30XS-H module was developed in accordance with the international standard ISO/EN 13849 and is certified by TÜV NORD. It meets the requirements of Functional Safety according to **PL c** (Performance Level c).

The 30XS-H version has been optimised for system expansion to include additional hydraulic functions.

The module is protected in a proven, robust and compact housing, specially designed for the off-highway automotive industry.

Special features

- **PL c certified**
- 30 inputs and outputs:
 - 10 analogue inputs
 - 4 timer inputs
 - 8 PWM outputs, high-side:
 - 6 with integrated current measurement
 - 2 digital outputs, low-side
 - 6 ratiometric voltage outputs
- Freely configurable Node-ID via pin
- Robust, very compact die-cast aluminium housing
- Waterproof, 48-pin male connection

Technical data

Ambient conditions	
Operating temperature	-40 .. +85 °C (with full load)
Operating altitude	0 .. 4,000 m
Supply voltage	8 .. 32 V
Peak voltage	40 V max.
Idle current	40 .. 120 mA
Standby current	≤ 1 mA
Current consumption	24 A max.
Fulfils the following standards	
CE mark	Compliant with 2004/108/EC
E-mark	ECE-R10 Rev.4
Functional safety	EN ISO 13849 PL c
EMC	EN 13309 / ISO 14982 / CISPR 25
ESD	ISO 10605
Electrical	ISO 16750-2 / ISO 7637-2-3, limited to 40 V with external load dump protection
IP class	EN 60529 IP 67 / ISO 20653 IP 6K9K
Temperature	ISO 16750-4
Vibration, shock, bump	ISO 16750-3
Communication profile	CANopen CIA DS 304/401
Dimensions and weight	
Housing dimensions	146.6 x 92 x 38 mm
Minimum clearance for connection	208 x 94 x 39 mm
Weight	330 g
Features ¹⁾²⁾³⁾⁴⁾	
Infineon XC 22xx microcontroller, 80 MHz, 768 kB int. Flash, 82 kByte int. RAM	
8 kByte EEPROM	
1 x CAN, 125 kbit/s up to 1 Mbit/s, termination configurable via pin	
2 x Node ID pin for optional configuration of the CANopen-ID	
IN	
6 x Analogue-IN 0 .. 5 V / 0 .. 10 V / 0 .. 25 mA or 25 mA LED lamps OUT configurable via software, PL c capable	
2 x Analogue-IN 0 .. 5 V / 0 .. 10 V / 0 .. 25 mA / 0 .. 65 kOhm or 25 mA LED lamps OUT configurable via software, PL c capable	
2 x Analogue-IN 0 .. 32 V with configurable pull-up/down, digital voltage input mode, PL c capable	
4 x Timer-IN (timer inputs 0.1 Hz .. 10 kHz) / Analogue-IN 0 .. 32 V configurable pull-up/down in digital voltage input mode, 1 encoder, PL c capable	
OUT	
6 x PWM-OUT / Digital-OUT 3 A high-side, current measurement, overload and wirebreak detection configurable as Timer-IN (10 Hz - 10 kHz) / Analogue-IN 0 .. 32 V with integrated pull-up, PL c capable	
2 x PWM-OUT / Digital-OUT 3 A high-side, overload and wirebreak detection configurable as 2 x Timer-IN (10 Hz-10 kHz) / Analogue-IN 0 .. 32 V with integrated pull-up, PL c capable	
2 x Digital-OUT 3 A low-side, for use as safety switch for high-side PWM-OUTs ⁵⁾	
6 x Analogue-OUT 15 % .. 85 % V _{Bat+} (ratiometric) configurable as 0 V .. 75 % V _{Bat+} with 10 kOhm low-side load or Analogue-IN 0 .. 32 V	
Dedicated power supply pins for high-side outputs	
Internal monitoring of board temperature, sensor supply, K15 input and battery voltage	
1 x sensor supply 5 V (100 mA)	

Note: ¹⁾ All I/Os and interfaces are protected against short circuit to GND and BAT+.

²⁾ All analogue inputs have 10 bit resolution.

³⁾ All analogue inputs can be used as digital inputs with configurable switching thresholds.

⁴⁾ All inputs can be used for functional safety if two inputs of the same type are connected in parallel for redundancy.

⁵⁾ These outputs are part of the safety design and cannot be controlled directly via the software.

Block circuit diagram

HY-TTC 30XS-H

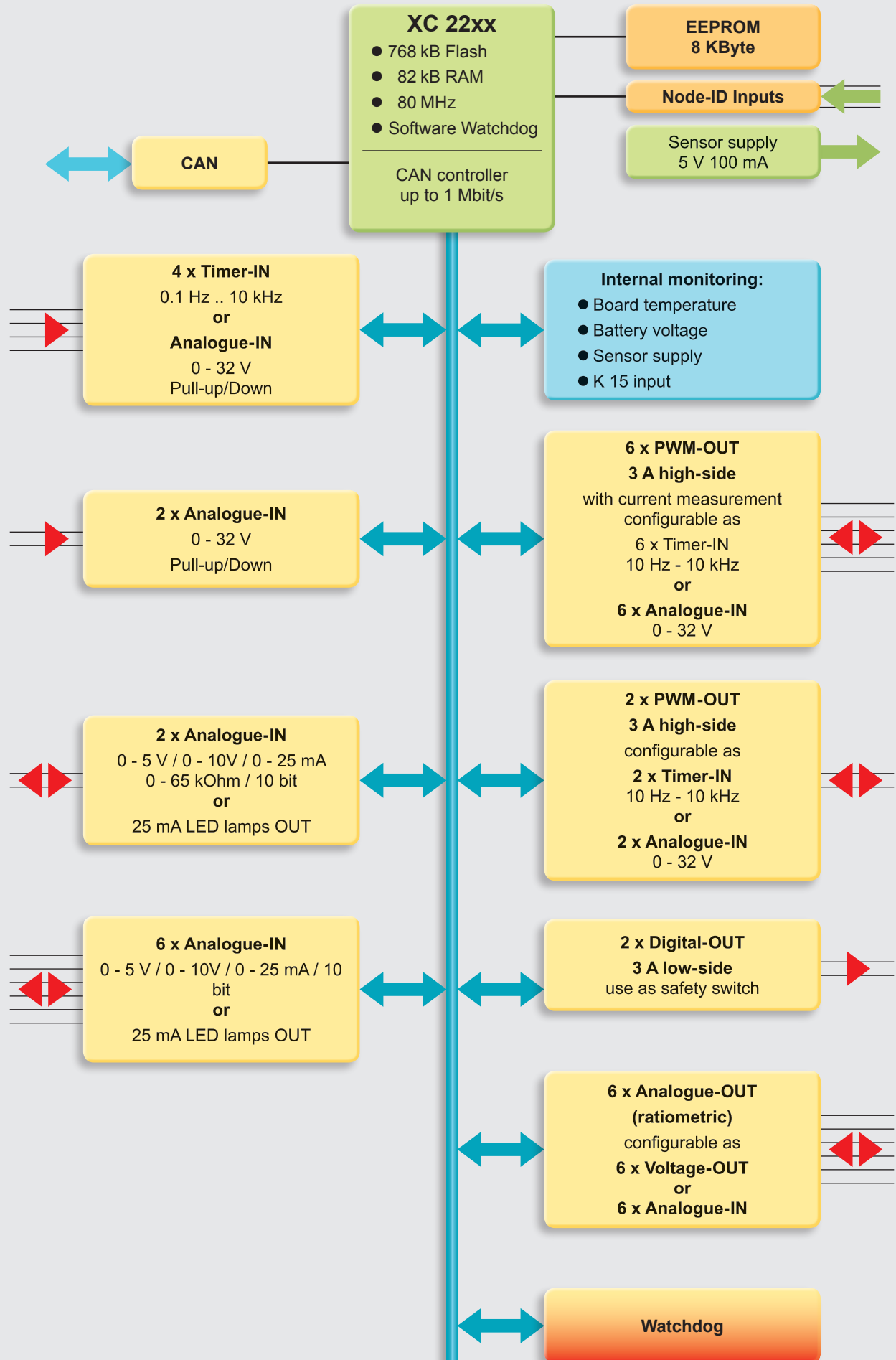

3

E 18.524.0/11.14

Model code

HY-TTC 30XS – H – F13 – 00 – Pc – 000

CAN protocol

F13 = CANopen safety slave

Equipment options

00 = standard

Functional safety

Pc = requirements for PL c

Modification number

000 = standard

Note

On instruments with a different modification number, please read the label or the technical amendment details supplied with the instrument.

Accessories

Appropriate accessories, such as electrical connectors, service tools, software, etc. can be found in the Accessories section.

Note

The information in this brochure relates to the operating conditions and applications described.

For applications and operating conditions not described, please contact the relevant technical department.

Subject to technical modifications.

Dimensions

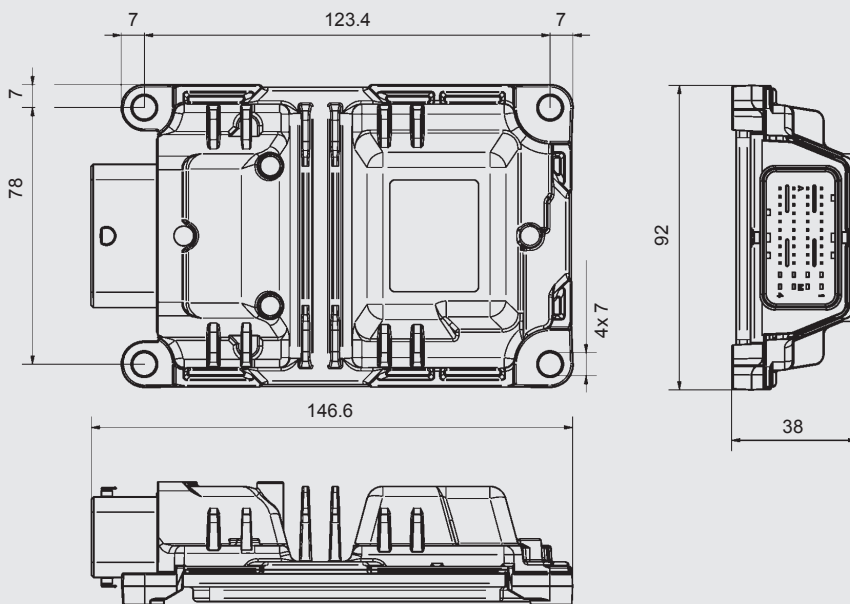

HYDAC ELECTRONIC GmbH

Hauptstraße 27
66128 Saarbrücken, Germany
Tel. +49 6897 509-01
Fax +49 6897 509-1726
E-mail: electronic@hydac.com
Internet: www.hydac.com

