



X-Series

Directional Control Valve DX-6

Key valve features

DX-6 is a sectional valve designed for max. operating pressures up to 350 bar and max. pump flows up to 180 l/min with "Q-inlet". For standard inlets without flow regulator the recommended max. pump flow is 140 l/min. The valve is available with 1 to 10 working sections per valve assembly.

DX-6 includes as standard a variety of sections, spools, spool controls and additional parts in a modular design. That makes the valve very flexible.

The valve is, as standard, setup for both manual and remote control. The manual controlled sections can either be with open spool ends or encapsulated. The encapsulation decreases in a significant way the risk for external leakage and makes the valve well adapted for applications in demanding environment. The spool controls for remote control are generally designed as complete modules for assembling on one of the valve sides.

DX-6 is in first place designed as an open center valve for fixed displacement pumps but can also be configured for variable displacement pumps. It is available with manual, hydraulic or electro-hydraulic proportional remote control.

DX-6 can be fully adapted for marine applications. The valve offers excellent operating characteristics, and good controllability on a wide range of machinery due to the specially designed spools.

Low and uniform spool forces are the result of careful balancing of the flow forces.

Q-inlet

The Q-inlet is designed with a flow control (Q-function) that by-passes the major part of the pump flow to tank when the system is idling, still giving access to full pump flow when the working sections are operated. Besides greatly reducing heat generation this also provides improved operating characteristics.

Applications

The DX-6 is ideal for applications where you need excellent control characteristics such as cranes, sky-lifts, garbage trucks, demountable bodies, excavators,

Technical data

Pressure and flow values*	
Max. operating pressure set per port:	
P1, P2, PM:	350 bar (35.0 MPa)
A, B:	400 bar (40.0 MPa)
T1, T2, T3:	20 bar (2.0 MPa)
Pp:	30 bar (3.0 MPa)
Tp:	5 bar (0.5 MPa)
X, Y:	25 bar (2.5 MPa)
Max. permissible flow either on port P1 or P2:	
Inlet without flow control function:	140 l/min
Inlet with flow control function:	180 l/min
Further data	
Spool stroke nominal:	+/- 7 mm
Spool control force spool control 9M1:	
Neutral position:	90 N
Max. spool stroke:	105 N
Permissible contamination level:	
Spool control M:	Equal or better than 20/18/14 as per ISO 4406
Spool control H, EH:	Equal or better than 20/17/13 as per ISO 4406
Viscosity range:	10 – 400 mm ² /s (cSt) Higher viscosity allowed at start up.
Leakage A, B → T at 100 bar, 32 cSt and 40 °C:	≤ 12 cc/min
Pressure fluid:	Mineral oil and syntetic oil based on mineral oil HL, HLP according to DIN 51524.
Fluid temperature range:	-15 °C up to +80 °C

* Higher values are possible, depending on application. For applications with demands that exceed stated data above, please contact us for consideration.
MTTFd value after consultation with HYDAC.

telescopic load handlers, skid-loaders, wheel loaders etc.

Remote control

As remote controlled the valve offers compact design with internal pilot oil supply, solenoids in a compact assembly on one side of the valve and integrated hand levers for manual override / manual operation. The integrated pilot supply system for the electro-hydraulic remote control makes the valve easy to install and gives a reliable remote control function. It is also possible to supply the pilot system externally.

The hydraulic remote control can also be configured both for internal and external pilot supply.

Accessories

- A wide choice of spools and spool controls for different flow combinations and for several applications and systems
- A full range of secondary valves
- Possibility of high pressure carry-over
- Inlet with electrical unloading valve
- Manual versions easily convertible to remote control

General overview

The drawing shows a 4-sectional valve with inlet and outlet. The sections are with various types of spool controls.

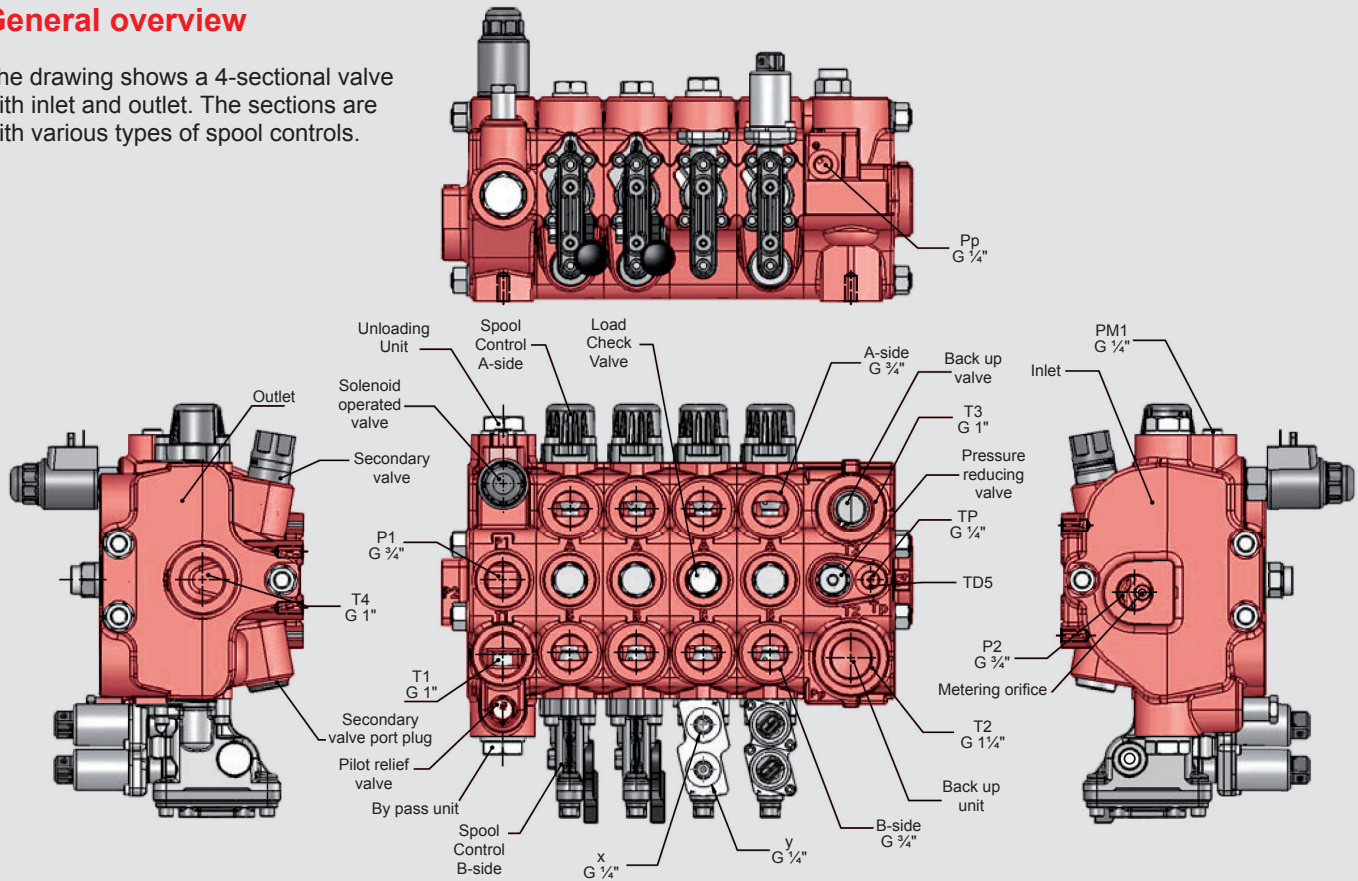

Pressure drop

Oil temperature / viscosity for all graphs: +40 °C / 32 cSt

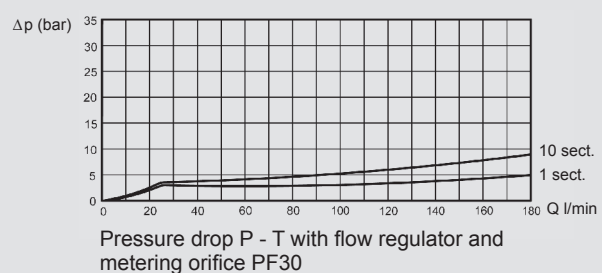
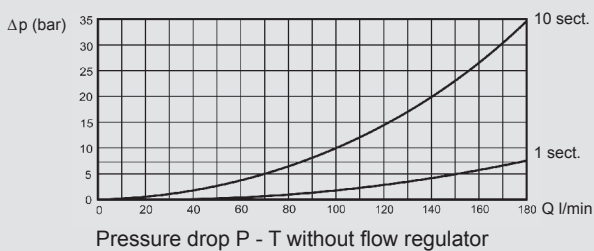
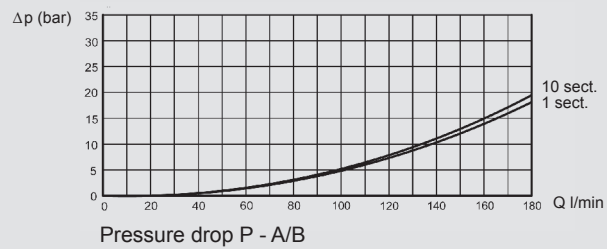
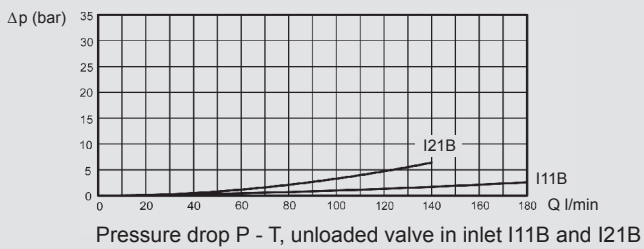
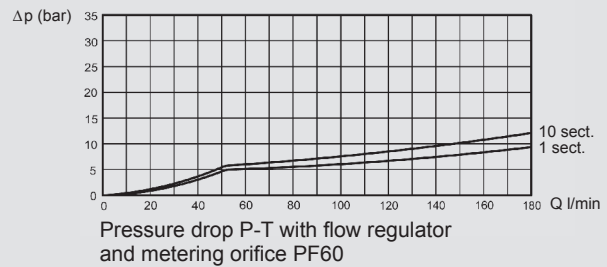
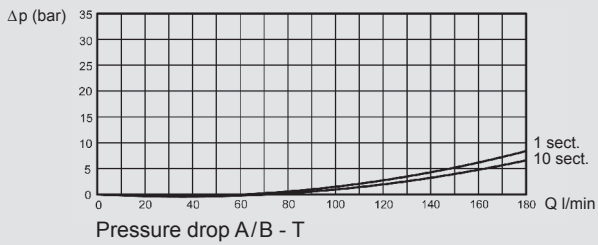

Note: The pressure drop curves are valid for sections equipped with spools that are fully open at maximum spool travel.

Dimensions and weight

The drawing shows a 4-sectional valve with inlet and outlet. The valve is configured for left hand inlet and shows the sizes of the ports for a valve with G-ports and the drawing also shows the marking of the ports.

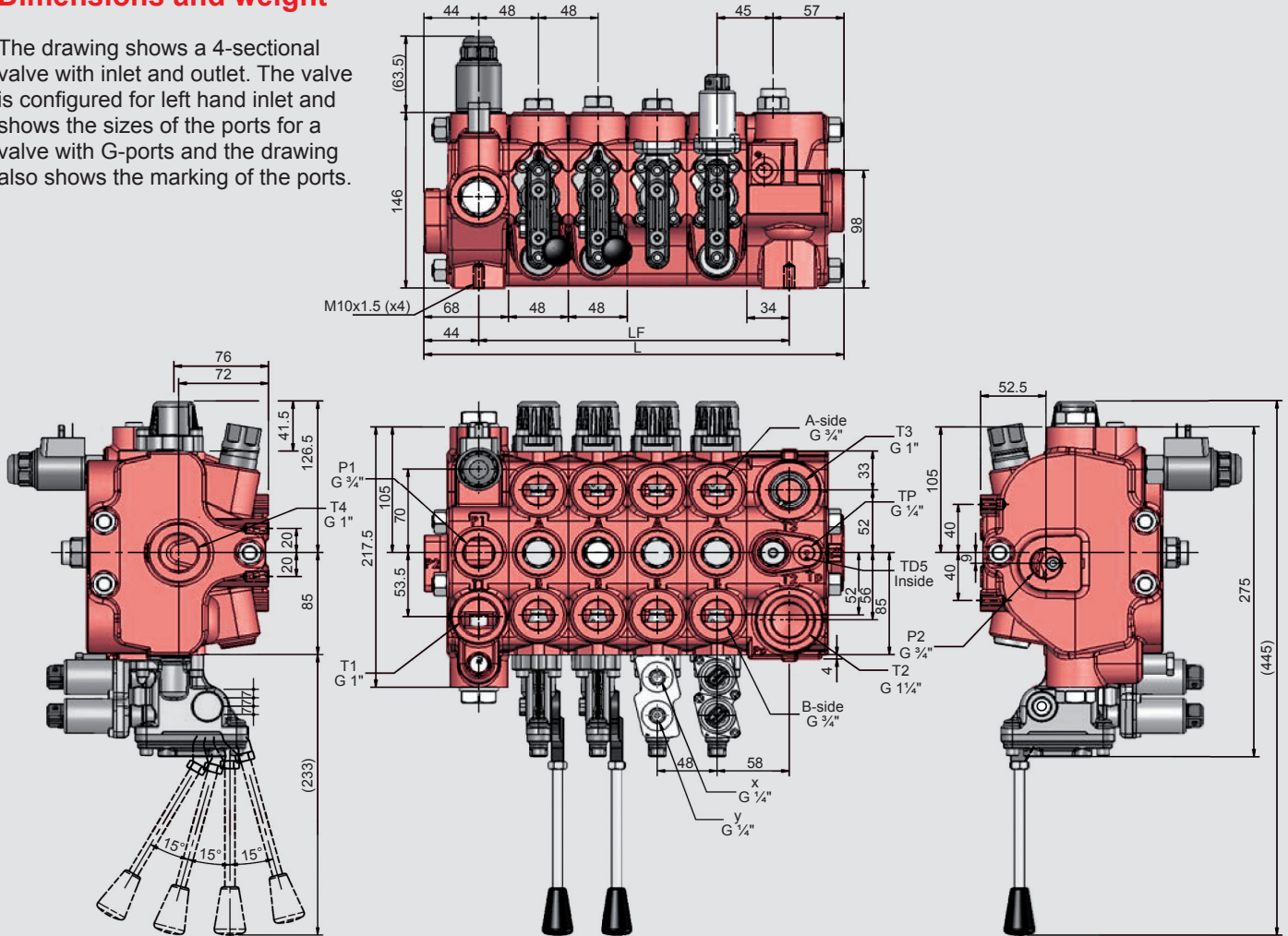

Weight

Inlet section I11B	6.5 kg
Inlet section I21B	5.5 kg
Working section	5.5 kg
Outlet section	7.0 kg
Outlet and workingsection US	6.5 kg
Mid-outlet section	7.0 kg

No. of working sections L [mm] LF [mm]

1	194	106
2	242	154
3	290	202
4	338	250
5	386	298
6	434	346
7	482	394
8	530	442
9	578	490
10	626	538

Measurements spool controls

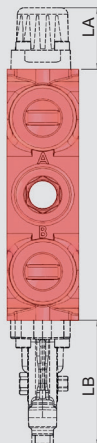

Type	LA mm	Type	LB mm
9M1	42	M1	85
9MO1	42	MO3	53
9R1	42	MO3F	53
11M1	74	H1	85
11MO1	74	H1F	85
11R1	95	EHM112	85
SM11	90	EHM124	85
SM21	109	EHM124F	85
SMO11	90	EHM124F	85
SMO21	109		
SR11	90		
SR21	109		

Dimensions and weight

The drawing shows a 4-section valve with standard inlet section, working sections manual operated and a multisection / outlet.

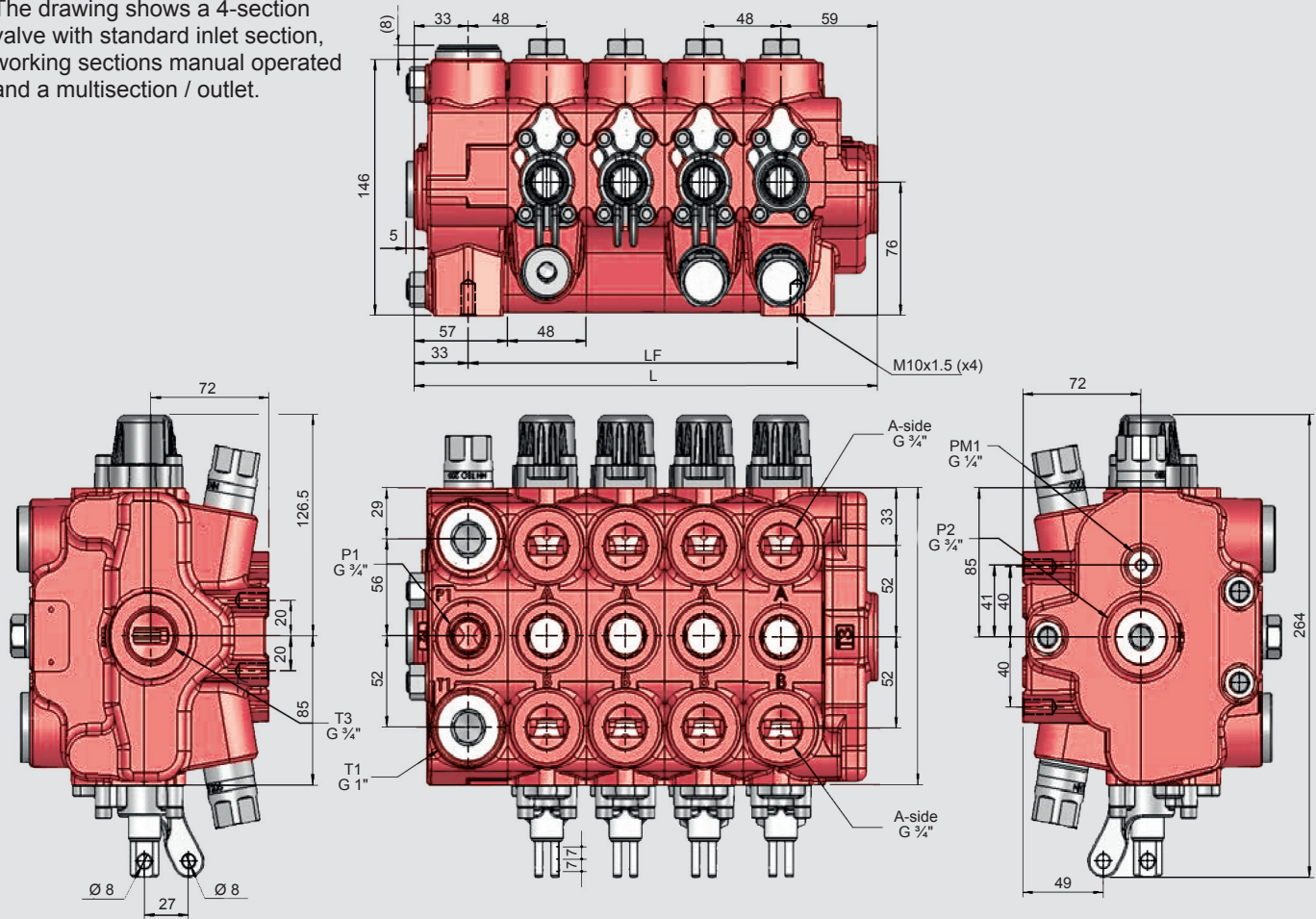

No. of working sections	L [mm]	LF [mm]
1	140	58
2	188	106
3	236	154
4	284	202
5	332	250
6	380	298
7	428	346
8	476	394
9	524	442
10	572	490

Inlet section I21B

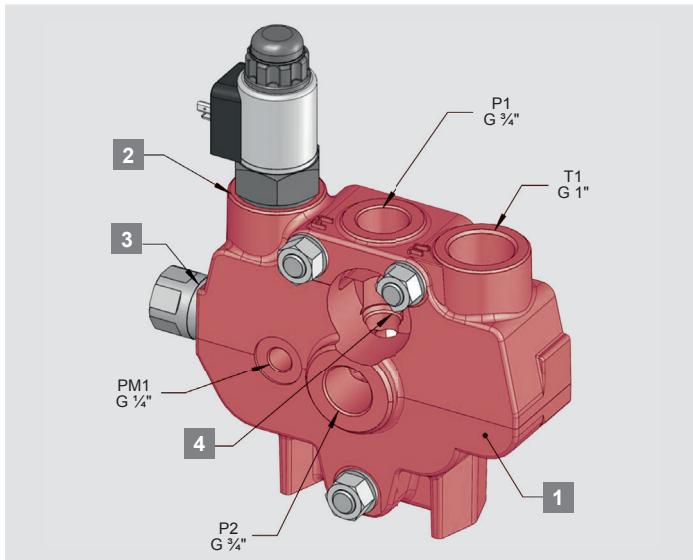

The standard inlet section I21B has 2 pump connections P1 and P2, a gauge port PM1 to monitor system pressure and a tank connection T1. Direct acting main relief valve (TBD201), and an unloading function via 2/2 solenoid valve (EU) for emergency dump of pump flow. The cavity (4) can be used to separate the parallel gallery from the center gallery to accomplish systems with parallel connection downstream of another valve or to control a variable pump.

Main relief function

TBD201 is adjustable and sealable for setting range 40 – 300 bar (4.0 – 30.0 MPa) with setting step 10 bar.

Unloading valve EU12 and EU24

EU12 and EU24 are 2-way, normally open, solenoid type cartridge valves. It is an option in all inlet sections.

It is intended for emergency stop and for pressure drop / heat generation reduction.

Rated flow:	150 l/min up to 280 bar
Rated flow:	100 l/min up to 350 bar
Power consumption:	18 W
Rated voltage EU12:	12 V
Rated voltage EU24:	24 V
Max voltage variation:	+/- 15 %
Duty factor*:	100 %
Connection:	EN 175301-803 form A
Protection class:	IP65

* Sufficient cooling must be secured.

The unloading valve has manual override, with twist pin operation. PE21 is the plug for the cavity.

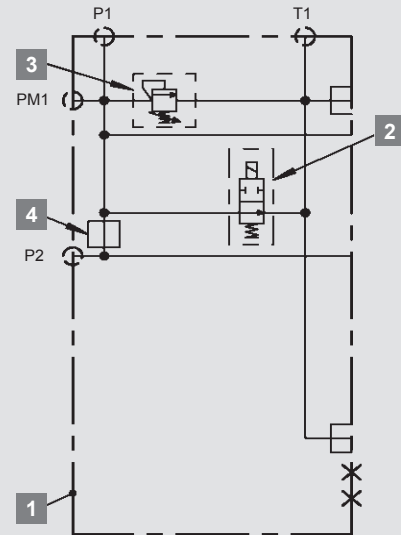

1	Inlet section	I21B
2	Unloading valve	EU24
3	Relief valve	TBD201
4	Cavity for plug PM02	N/A

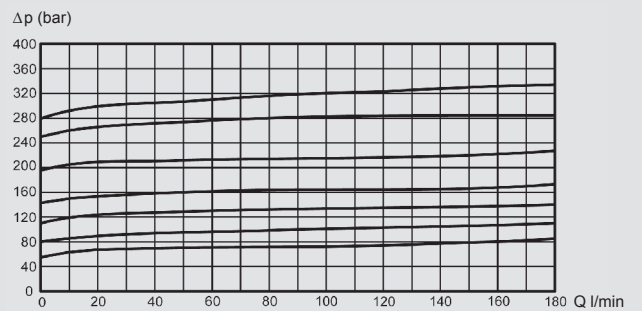

Characteristic main relief function (TBD201)

Inlet section I11B

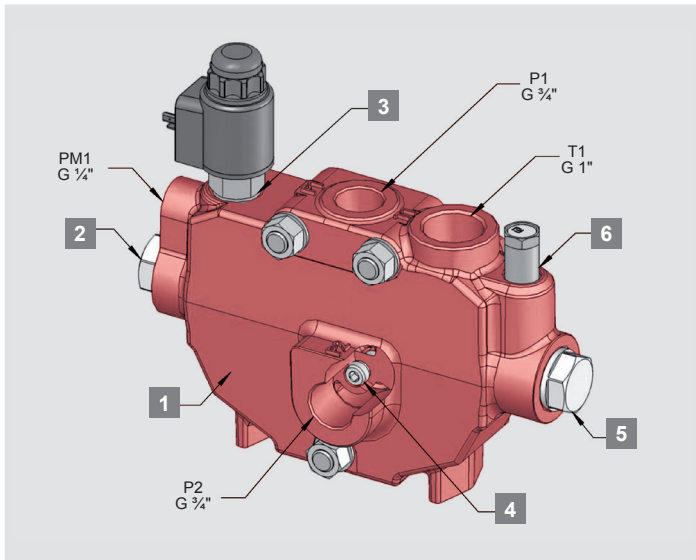

Flow control function

The inlet section I11B with its integral Q-function provides by-pass of pump flow to tank in idling condition, thereby reducing pressure drop and heat generation. It also reduces flow forces and makes the control response to large extent unaffected by varying pump flows. This contributes to the excellent operating characteristics achievable with DX-6.

The regulated flow into the center gallery is set by an exchangeable metering orifice (4).

In case the I11B inlet section is configured with metering orifice PF60, this orifice determines the high pressure carry-over flow to downstream arrangements.

Unloading function

An unloading spool along with an electrical operated pilot valve forms the unloading function. The unloading spool both unloads the pump flow to tank and as well disconnects the valve's parallel gallery from the pump.

Together with a load holding valve, DX-6 achieves a very safe emergency dump of pump flow to tank.

E912 and E926 are 2-way, normally open, solenoid type cartridge valves. It is an option in all inlet sections. It is intended for emergency stop and for pressure drop / heat generation reduction.

Rated flow:	40 l/min
Power consumption:	18 W
Rated voltage E912:	12 V
Rated voltage E926:	24 V
Max voltage variation:	+/- 15 %
Duty factor*:	100 %
Connection:	EN 175301-803 form A
Protection class:	IP65

* Sufficient cooling must be secured.

The unloading valve has manual override, with twist pin operation. PE20 is the plug for the cavity.

Main relief function

The by pass unit FK29 in combination with the relief valve TB 12 form the pilot operated relief valve function.

TB12 is adjustable and sealable for setting range 40 – 350 bar (4.0 – 35.0 MPa) with setting step 10 bar.

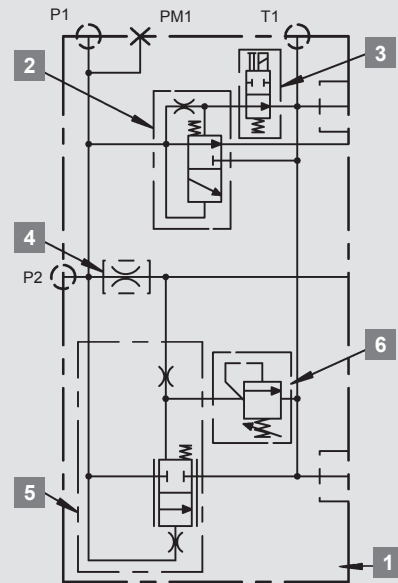

1	Inlet section	I11B
2	Unloading unit	FU29
3	Solenoid operated valve	E926
4	Metering orifice for center gallery flow	PF60
5	By-pass flow control unit	FK29
6	Pilot relief valve	TB12

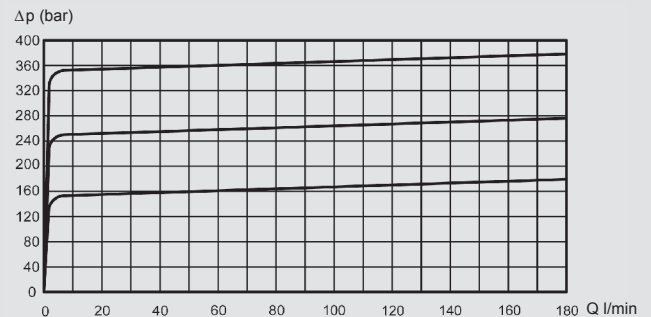

Characteristics main relief function

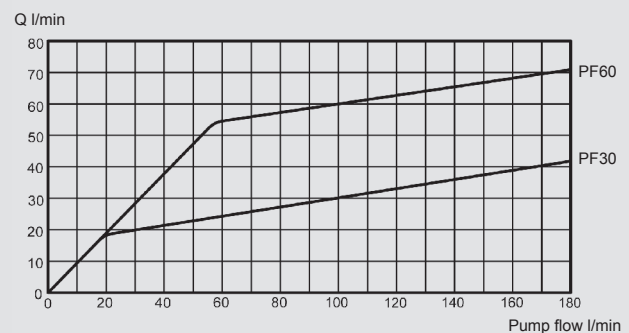

Characteristics regulated flow

Oil temperature / viscosity for all graphs: +40 °C / 32 cSt

Working section S12L

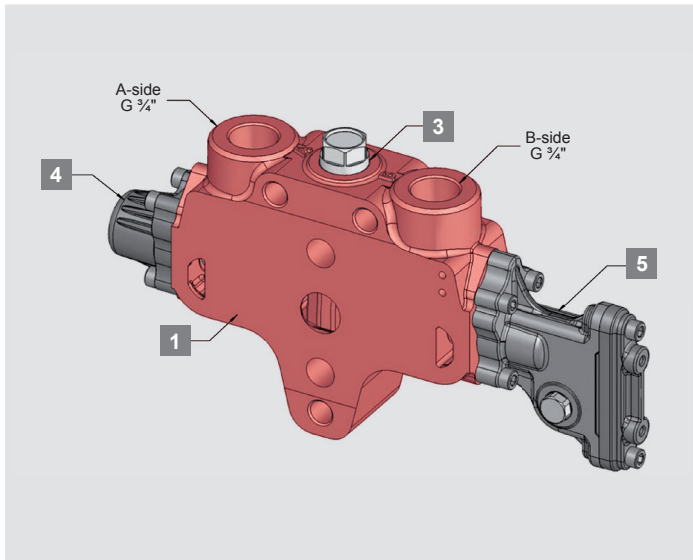

Working section S12L for both manual and remote operation. The example shows a section configured for manual operation with the spring centering spool control on A-side and encapsulated lever mechanism on B-side. The section S12L includes a load check valve.

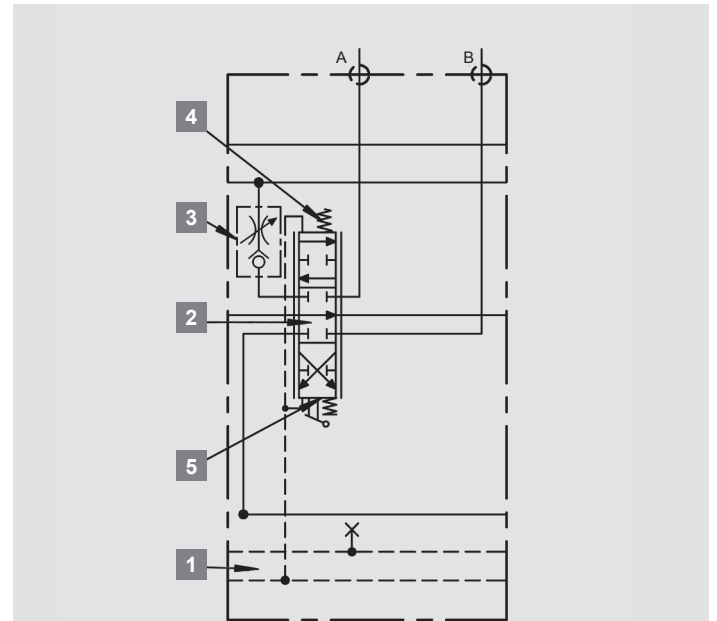

1	Working section	S12L
2	Spool	1XY
3	Load check valve	MF29
4	Spool control, A-side	9M1
5	Spool control, B-side	M1

Working section S22L

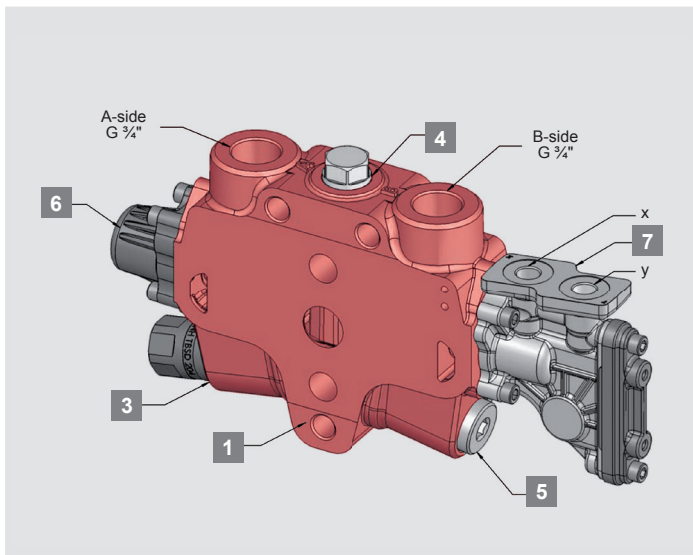

Working section S22L for both manual and remote operation. The example shows a section configured for hydraulic remote control with the spring centering spool control on A-side and the ports for control pressure on the B-side. The section S22L includes load check valve and cavities for secondary valves of type TBD/TBSD205.

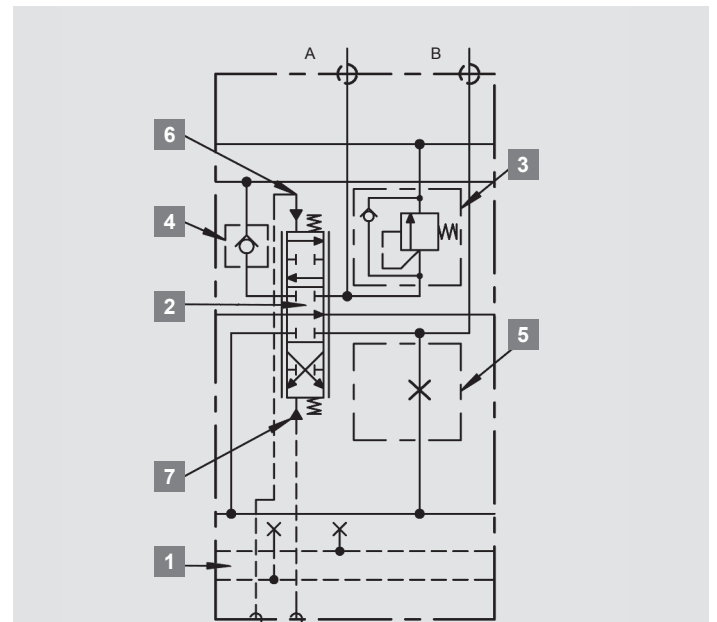

1	Working section	S22L
2	Spool	1XY
3	Secondary valve	TBSD205
4	Load check valve	MB29
5	Secondary valve port plug	P204
6	Spool control, A-side	9R1
7	Spool control, B-side	H1

Working section S32L

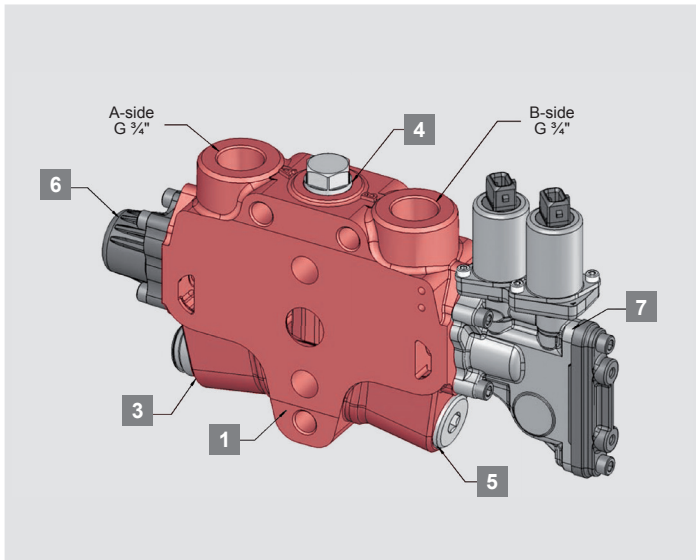

Working section S32L for both manual and remote operation. The example shows a section configured for electro-hydraulic remote control with the spring centering spool control on A-side and the proportional solenoids on the B-side.

The section S32L includes load check valve and cavities for secondary valves of type TBSD280.

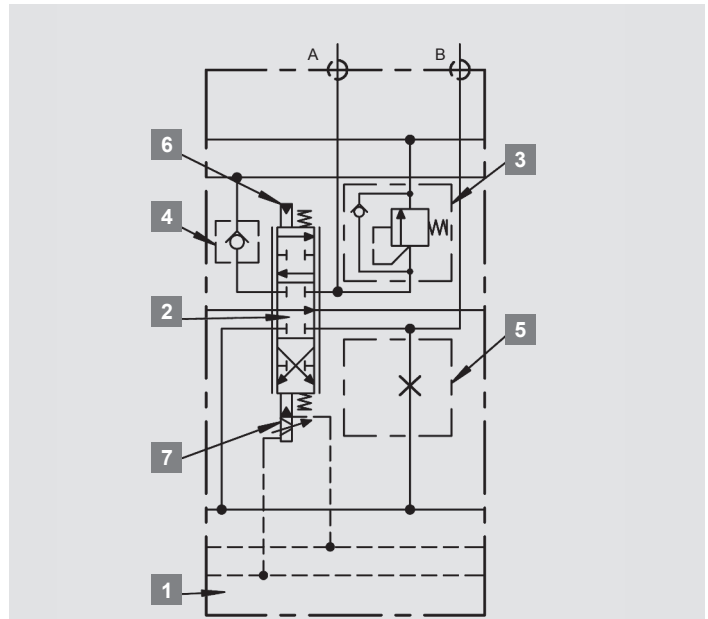

1	Working section	S32L
2	Spool	1XY
3	Secondary valve	TBSD280
4	Load check valve	MB29
5	Secondary valve port plug	P280
6	Spool control, A-side	9R1
7	Spool control, B-side	EH1XX

Load check valve

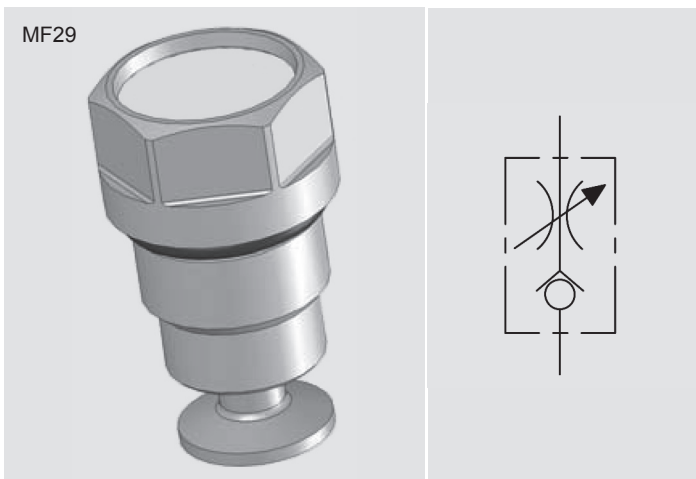

The main function of the load check valve is to prevent the load from moving backwards if the load pressure is higher than pump pressure when operating.

MB29
Load check valve.

MF29
Load check valve with adjustable flow limitation. MF29 restricts the flow out from a section. Typical application is a slewing function.

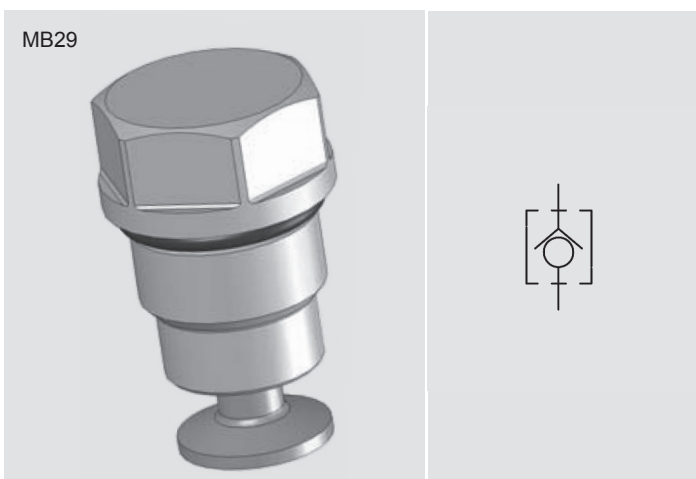

Outlet section U11B

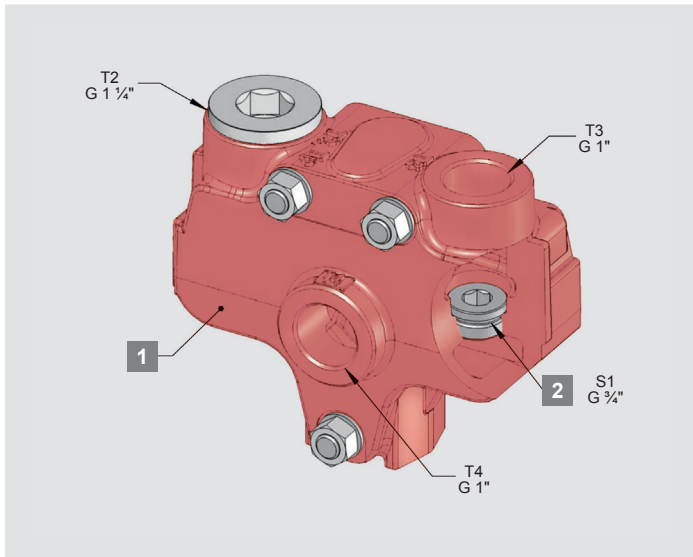

The standard outlet section U11B has 3 tank connection ports T2, T3 and T4.

Port T3 is used for high pressure carry-over function (HPCO) when plug S29 is installed in the S1 cavity (see example).

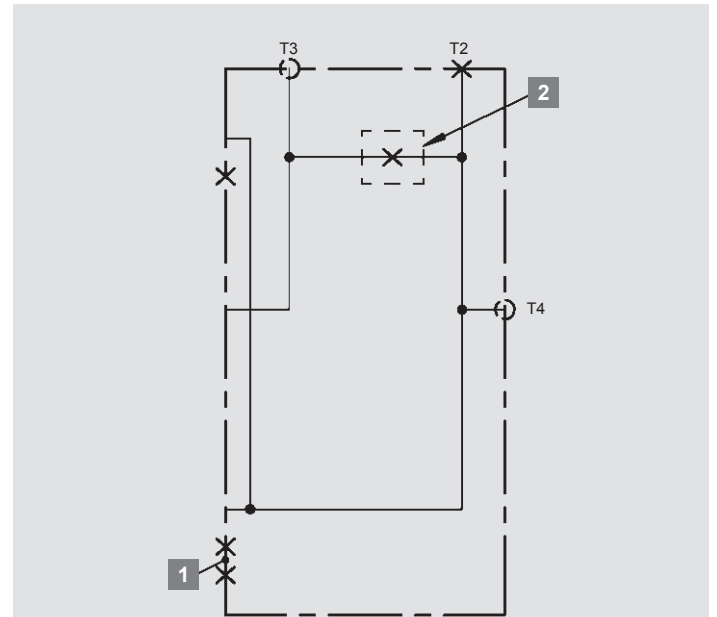

1	Outlet section	U11B
2	Carry-over plug	S29

Outlet section U11L

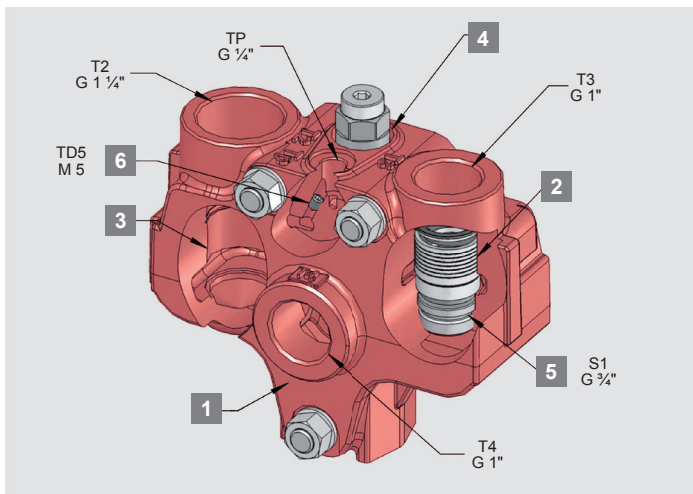

The outlet section U11L with integrated pilot pressure supply for a valve with electro-hydraulic remote controlled working sections. Same configuration can be used for pilot pressure supply, via port Pp, to a hydraulic controller for use with hydraulic remote controlled working sections.

To ensure sufficient pressure for the pilot circuit a start up pressure is generated by the back up valve BUP14 installed in cavity 2. The back up valve can be used in combination with HPCO plug S29. A pressure reducing valve TRA63 limits the pressure in the pilot circuit.

Because the pilot pressure is supplied from the parallel gallery an emergency stop will also unload the pilot pressure.

It is recommended to drain the return flow in the pilot circuit via port Tp direct to tank in separate piping. This is accomplished by PMS5 installed in cavity 6. Note: The port Tp must not be plugged when PMS5 is installed.

The outlet section U11L can be configured with a back up valve (BUP14 installed in cavity 3) for an increased pressure in the return passage to prevent cavitation in severe conditions.

This is accomplished without compromising the pressure drop P – T at idling.

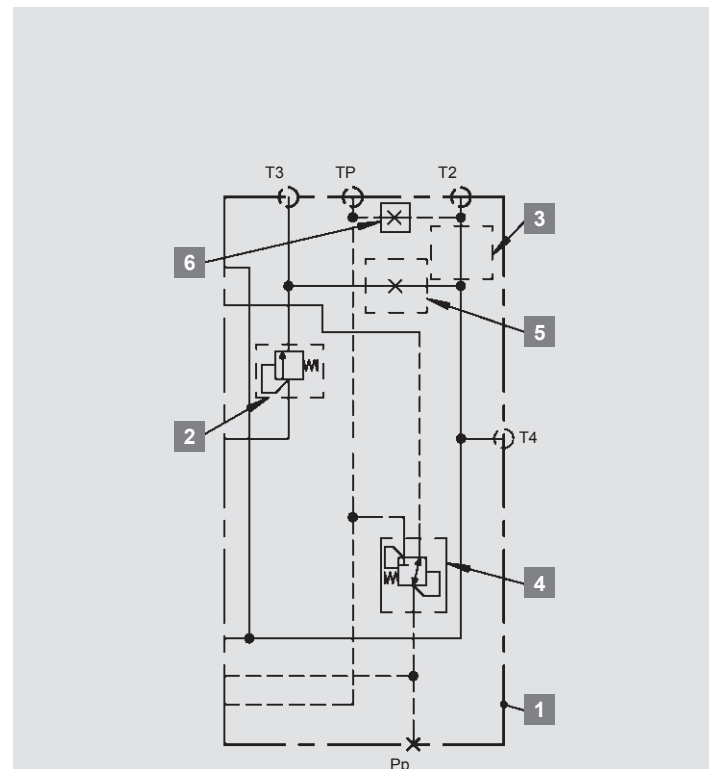

1	Outlet section	U11L
2	Back up valve	BUP14
3	Cavity for back up valve BUP14 for anticavitation	
4	Pressure reducing valve	TRA63
5	Carry-over plug	S29
6	Plug for pilot drain	PMS5

Outlet and working section US22L

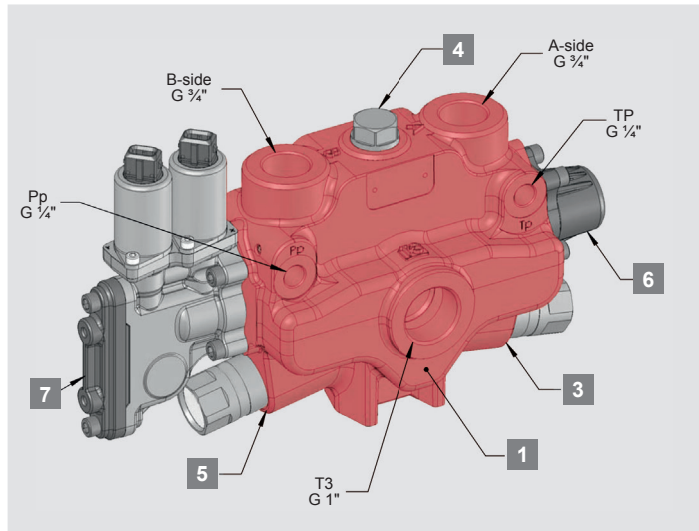

The US22L is an outlet section with integrated spool section, T3 port for tank connection for both manual operation and remote control with external pilot pressure supply. High pressure carry-over function is achieved with SG31 installed in port T3. Pp – supplied pilot pressure, Tp – pilot drain.

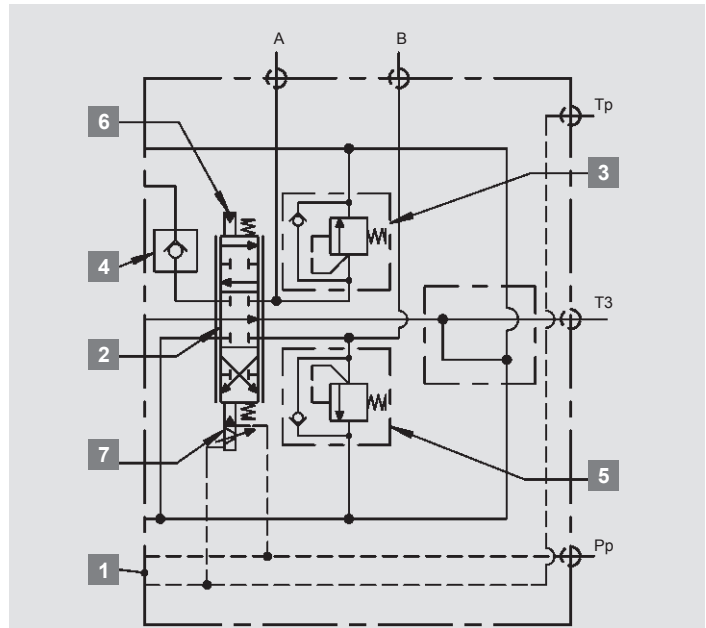

1	Outlet and working section	US22L
2	Spool	1XY
3	Secondary valve	TBSD205
4	Load check valve	MB29
5	Secondary valve port plug	TBSD205
6	Spool control, A-side	9R1
7	Spool control, B-side	EH1XX

Mid-outlet N11B

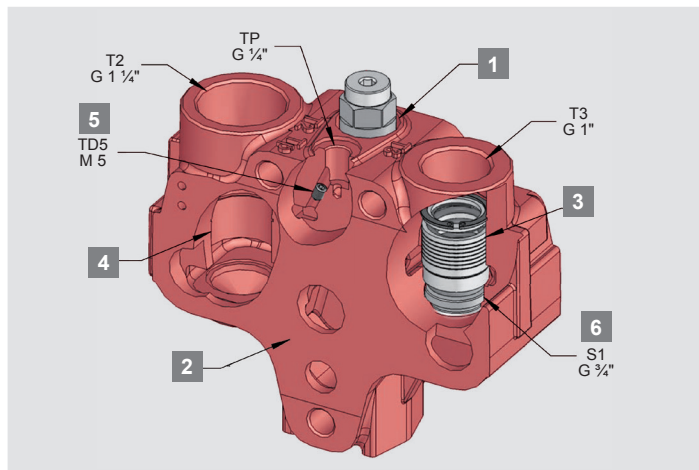

The mid-outlet section N11B with integrated pilot pressure supply for a valve with electro-hydraulic remote controlled working sections. Same configuration can be used for pilot pressure supply, via port Pp, to a hydraulic controller for use with hydraulic remote controlled working sections.

To ensure sufficient pressure for the pilot circuit a start up pressure is generated upstream of the mid-outlet by the back up valve BUP14 installed in cavity 3. The back up valve can be used in combination with HPCO plug S29. A pressure reducing valve TRA63 limits the pressure in the pilot circuit.

Because the pilot pressure is supplied from the parallel gallery an emergency stop will also unload the pilot pressure.

It is recommended to drain the return flow in the pilot circuit via port Tp direct to tank in separate piping. This is accomplished by PMS5 installed in cavity 5. Note: The port Tp must not be plugged when PMS5 is installed.

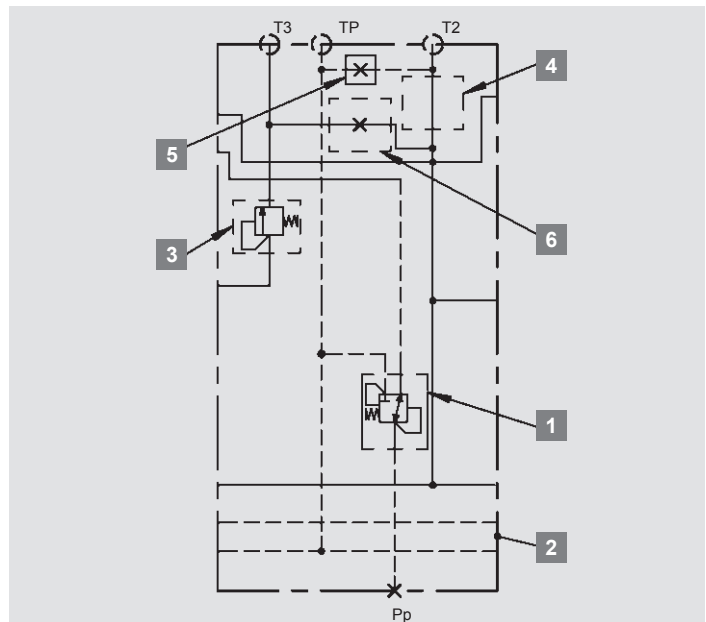







1	Pressure reducing valve	TRA63
2	Mid-outlet section	N11B
3	Back up valve	BUP14
4	Cavity for back up valve BUP14 for anticavitation	
5	Plug for pilot drain	PMS5
6	Carry-over plug	S29

The mid-outlet section N11B can be configured with a back up valve (BUP14 installed in cavity 4) for an increased pressure in the return passage to prevent cavitation in severe conditions. This is accomplished without compromising the pressure drop P – T at idling.

Spool controls A-side







The spool controls are designed in a modular system for a high degree of flexibility.

The sections are basically symmetric but as standard machined either for left or right hand inlet with spool controls on A-side and B-side.

	
Spool control 9	
9M1: Manual spring centered 3 pos. encapsulated.	
9MO1: Manual spring centered 3 pos. open spool ends.	
9R1: Remote spring centered 3 pos.	
Spool control 11	
11M1: Manual spring centered 4 pos. encapsulated.	
11MO1: Manual spring centered 4 pos. open spool ends.	
11R1: Remote spring centered 4 pos.	
Spool control S*	
SM11: Manual spring centered 3 pos. spool position indicator.	
SMO11: Manual spring centered 3 pos. open spool ends spool position indicator.	
SR11: Remote spring centered 3 pos. spool position indicator.	

Spool controls B-side

Remote spool controls can be with or without manual override. The valve is, as standard setup for both manual and remote control.

	
Spool control M	
M1: for manual lever 3 pos.	
MO3: for manual lever 3 pos. open spool ends.	
MO3F: for manual lever 4 pos. open spool ends.	
Spool control H	
H1: Hydraulically 3 pos. manual override available as option (H1M1).	
H1F: Hydraulically 4 pos. manual override available as option (H1M1F).	
Spool control EHM	
EHM1**: Electro-hydraulically manual override 3 pos., without manual override as option (EH1**).	
EHM**F: Electro-hydraulically manual override 4 pos., without manual override as option (EH1**F).	

* Standard connector M12x1, also available in Deutsch connector.

** 12 or 24 V DC.

Solenoid valve for EHP – ER12 / 24

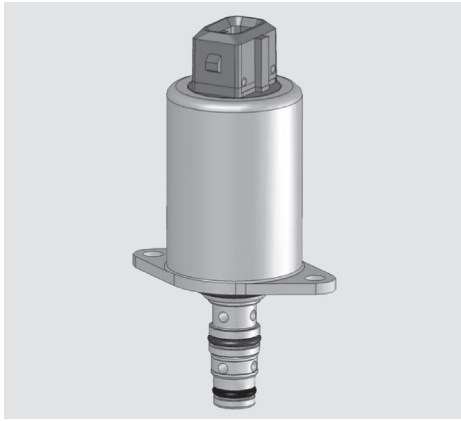

The solenoid valves are 3/2-way electrically operated pressure reducing valves used to provide controlled pilot pressure to operate valve spools.

Functional principle:	PWM (Pulse Width Modulation)
Duty factor:	100 %
Connection:	AMP Junior-Power-Timer
Recommended PMW frequency:	100 Hz
Protection class:	IP 65
Ambient temperature:	-30 °C up to +80 °C

ER12

Rated voltage:	12 V DC
Starting current:	600 mA
Fully shifted:	1,500 mA
Coil resistance +20 °C:	4.72 Ohm

ER24

Rated voltage:	24 V DC
Starting current:	300 mA
Fully shifted:	750 mA
Coil resistance +20 °C:	20.8 Ohm

Levers

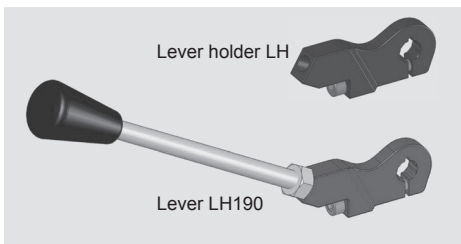

Lever LH190

The lever holder LH is for use together with spool control of type M1/EHM.

The lever holder LH can be delivered separate or in combination with a lever.

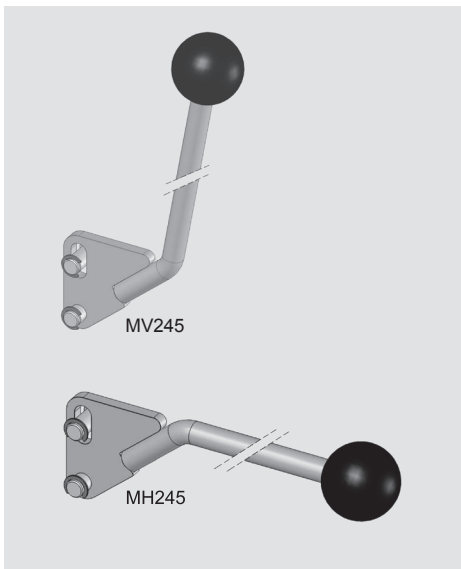

Lever MV/MH

Lever for use in combination with open spool ends and a bracket M03/M03F. When mounted on a valve, the lever MH stands in a horizontal position and MV stands in a vertical position.

Lever length 145 or 245 mm.

Spools – main design parameters

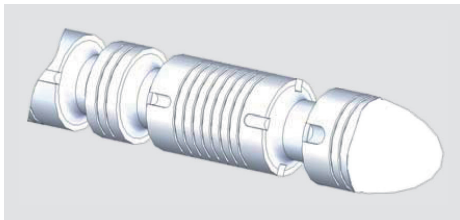

Generally the spools are divided in 3 different flow ranges.

The position indicating regulated flow range is replaced by X,
0 = full pump flow, 3 = 30 l/min and 6 = 60 l/min.

The position indicating pump flow is replaced by Y, 3 = 80 l/min,
4 = 110 l/min and 6 = 160 l/min.

The last three positions in the code are design parameters.

In the table only the accessibility of different functions are shown.

Pos. 1 – Functionality

	Spools for general use	
	Function	Code
	Double acting	1XY
	Single acting	2XY
	Double acting, 4 th pos. for float	3XY
	Motor spool A/B – T	4XY
	Regenerative	8XY

Pos. 2 – Regulated center flow – X in the code above

0 = Full pump flow i. e. no regulated flow
3 = 30 l/min regulated flow (use with inlet section I11B)
6 = 60 l/min regulated flow (use with inlet section I11B)

Pos. 3 – Pump flow supplied – Y in the code above

3 = 80 l/min +/-10 l/min
4 = 110 l/min +/-20 l/min
6 = 160 l/min +/-30 l/min

Example:

Spool 136xxx – double acting spool with 30 l/min regulated flow and 160 l/min pump flow, xxx in the code are design parameter.

The DX-6 spools are available in a variety of flows and styles to accommodate most design requirements. Since the development of spools is a continuous process and all available spools are not described in this data sheet, contact HYDAC for advice on choosing spools in order to optimize your valve configuration.

Secondary valves

Port relief valve TBD205

TBD205 is a differential area, direct acting relief valve, for the secondary circuit. It is adjustable and sealable.

Setting range for TBD205:

- 40 – 300 bar
(4.0 – 30.0 MPa)
- Setting range step: 10 bar

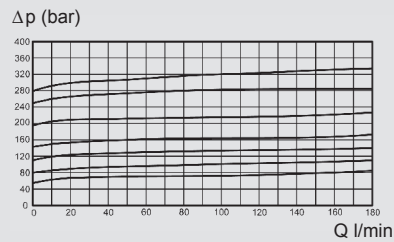

Relief characteristics TBD205

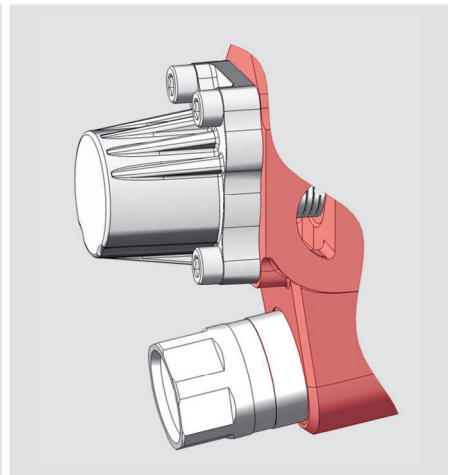
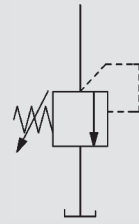

Port relief and anticavitation valve TBSD205

TBSD205 is a differential area, direct acting relief and anticavitation valve, for the secondary circuit. It is adjustable and sealable.

Setting ranges for TBSD205:

- 40 – 300 bar
(4.0 – 30.0 MPa)
- Setting range step: 10 bar

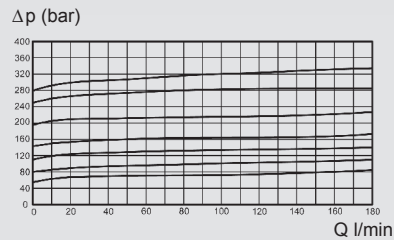

Relief characteristics TBSD205

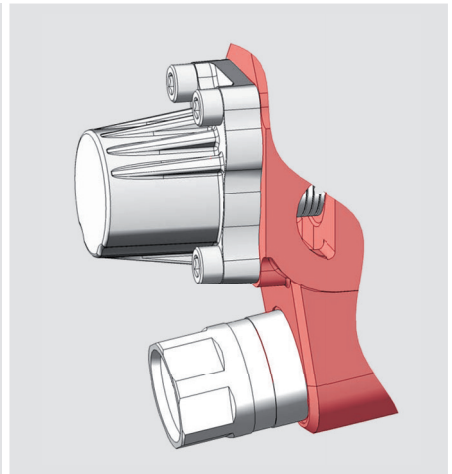
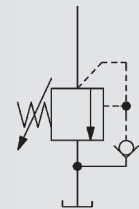

Port relief and anticavitation valve TBSD280

TBSD280 is a direct acting relief and anticavitation valve, for the secondary circuit. It is fixed and sealable.

Setting ranges for TBSD280:

- 90 – 400 bar
(9.0 – 40.0 MPa)
- Setting range step: 10 bar

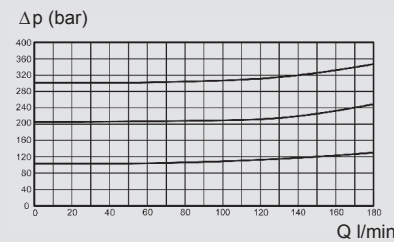

Relief characteristics TBSD280

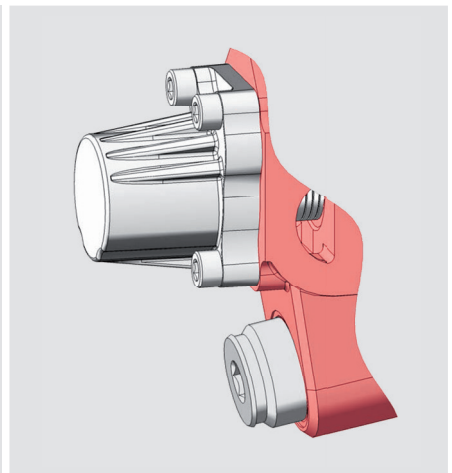
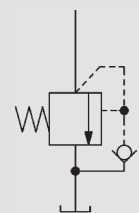

Anticavitation valve SB204

The anticavitation valve ensures that, in the event of a lower pressure in the cylinder port than in the tank, oil can be drawn from the system oil tank to the consumer.

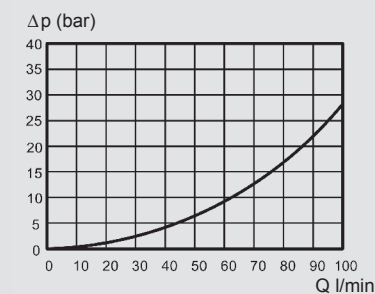

Anticavitation characteristics
TBSD205 and SB204

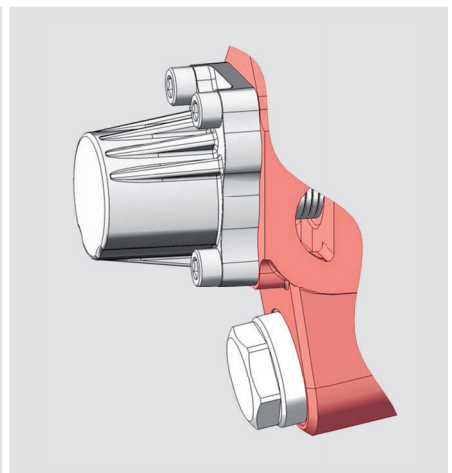
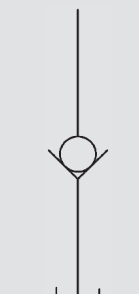

Secondary valves

Anticavitation valve SB280

The anticavitation valve ensures that, in the event of a lower pressure in the cylinder port than in the tank, oil can be drawn from the system oil tank to the consumer.

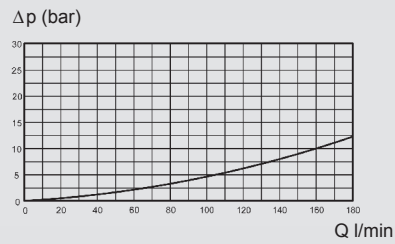

Anticavitation characteristics
TBSD280 and SB280

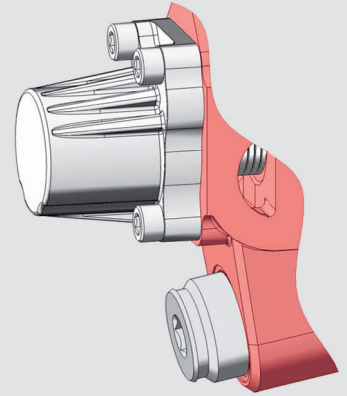

Typical hydraulic diagrams

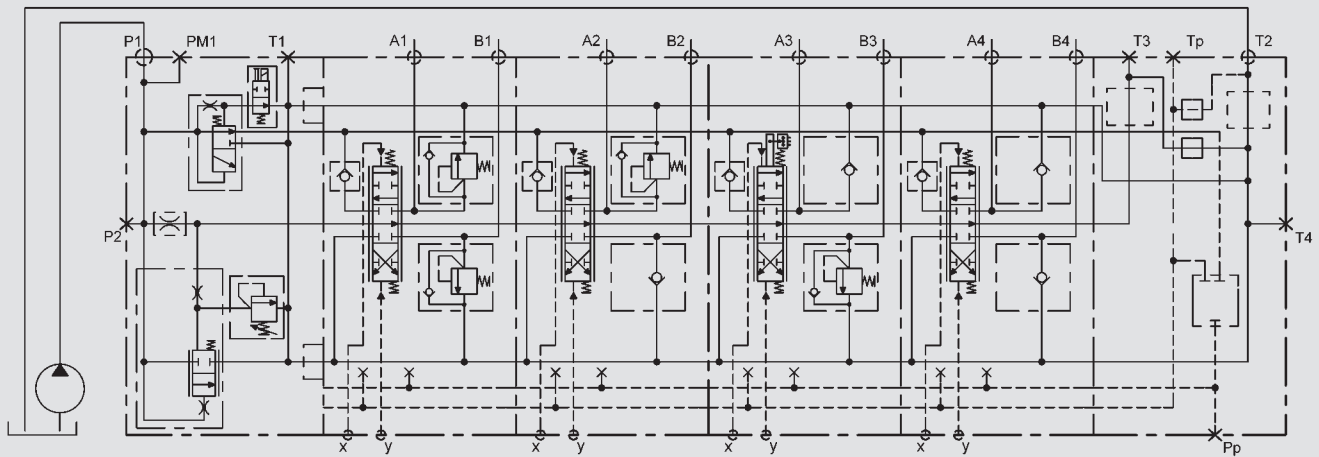

This example shows a DX-6 hydraulic diagram with:

- the inlet section with flow control function and electrical unloading. A metering orifice determines the center gallery flow. A pilot operated relief valve in combination with the flow control performs the main relief valve function.
- 4 working sections all with double acting cylinder spools hydraulically actuated. Section 3 with a spool position indicator.
- Outlet section machined for pilot pressure supply, back up pressure and high pressure carry-over (HPCO) but in the example configured with cavity plugs.

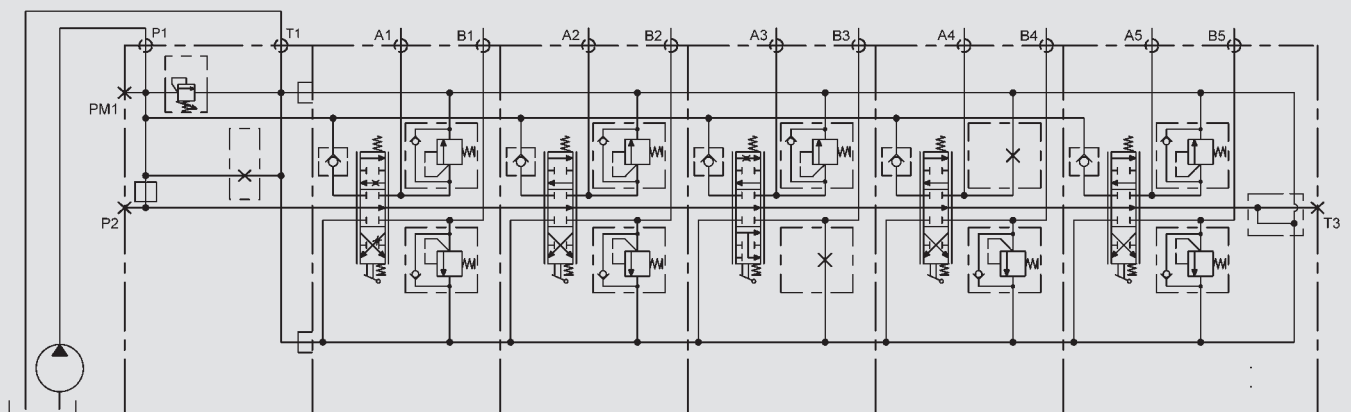

This example shows a DX-6 hydraulic diagram with:

- the inlet section of standard type with a direct acting main relief valve.
- 5 working sections all manual operated. Section 3 with 3-position regenerative spool.
- The outlet section with integrated working section with option for HPCO.

Note

The information in this brochure relates to the operating conditions and applications described.

For applications or operating conditions not described, please contact the relevant technical department. Subject to technical modifications.



Nordhydraulic
HYDAC INTERNATIONAL

Head Office
HYDAC INTERNATIONAL
GMBH

Industriegebiet
66380 Sulzbach/Saar
Germany

Phone: +49 6897 509-01
Fax: +49 6897 509-577

E-mail: mobilevalves@hydac.com
Internet: www.hydac.com