



Multi-Station Gauge Isolator MS / MSL



MS 2



MSL 2



MS 4



MS 6



MS 5



MS 7

1. DESCRIPTION

1.1. GENERAL

Multi-station gauge isolators are designed to check different pressures in a hydraulic system.

There are models with a built-in pressure gauge for different pressure ranges or models to which a separate pressure gauge can be connected.

If it is necessary for the system pressure to be retained during the measuring process, the leakage-free model must be used.

1.2. MULTI-STATION GAUGE ISOLATORS TYPE MS 2

with built-in pressure gauge, are designed to check up to 6 different pressures in a hydraulic system. The gauge is built directly into the selector knob, therefore eliminating the need for a separate gauge. The pressure can be read when the arrow on the rotary knob is pointing to one of the six measuring positions. By turning the knob each of the six measuring positions can be selected. Between each measuring position there is a zero position to relieve the gauge pressure. A built-in detent locks any selected position. Different gauges are available for different pressure ranges. The gauges are filled with a special damping fluid to prolong the gauge life.

1.3. MULTI-STATION GAUGE ISOLATORS TYPE MSL 2

with built-in pressure gauge, fulfil the same function as Type MS 2, however the measuring points are shut off leakage-free. The MSL 2 is suitable for hydraulic systems where the pressure must be retained and therefore a leakage-free gauge isolator must be used.

1.4. MULTI-STATION GAUGE ISOLATORS TYPE MS 4 / MS 6

without pressure gauge, are designed to check up to 6 or 9 different pressures in a hydraulic system. The gauge has to be mounted separately and must be connected to port M of the gauge isolator by means of a pipe or hose. The pressure can be read when the arrow on the rotary knob is turned to one of the measuring positions and pushed against a spring force in an axial direction. When the knob is released it returns to its original position and the gauge is connected to the tank port. A built-in detent locks any of the selected positions.

1.5. MULTI-STATION GAUGE ISOLATORS TYPE MS 5 / MS 7

without pressure gauge, are designed to check up to 5 or 8 different pressures in a hydraulic system. The gauge has to be mounted separately and must be connected to port M of the gauge isolator by means of a pipe or hose. The pressure can be read when the arrow on the rotary knob is pointing to one of the measuring positions. By turning the rotary knob each of the measuring positions can be selected. An additional 0 position allows pressure from the gauge to be released to the tank. A built-in detent locks any of the selected positions.

2. TECHNICAL SPECIFICATIONS

to VDI 3267

2.1. GENERAL

2.1.1 Designation and Symbol

Multi-station gauge isolator

Type MS 2/MSL 2

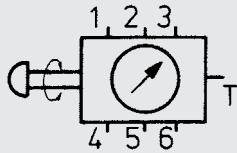

Type MS 4

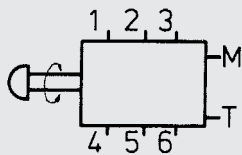

Type MS 5

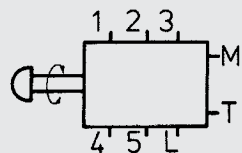

Type MS 6

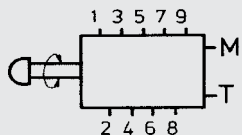

Type MS 7

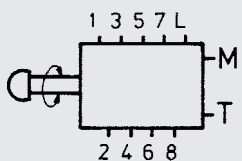

2.1.2 Model code (also order example)

MSL 2 A 2 . 0 / 315

Multi-station gauge isolator

MS
MSL

with built-in pressure gauge

Type of connection

A = G 1/4

G = 1/4 NPTF

H = 7/16 - 20 UNF

only for MSL

Type code

Modification number

Scale

40 = max. eff. indication range 40 bar / 570 psi (Scale 63 bar / 900 psi)

63 = max. eff. indication range 63 bar / 900 psi (Scale 100 bar / 1400 psi)

100 = max. eff. indication range 100 bar / 1400 psi (Scale 160 bar / 2300 psi)

180 = max. eff. indication range 180 bar / 2600 psi (Scale 250 bar / 3600 psi)

315 = max. eff. indication range 315 bar / 4500 psi (Scale 400 bar / 5700 psi)

Supplementary details

V = Viton seals

D = Connection for external pressure gauge

(only for MSL without built-in pressure gauge)

Multi-station gauge isolator

MS 4 A 2 . 0 /

Type

4 = turn and press to read (6 positions)

5 = turn to read (5 positions)

6 = turn and press to read (9 positions)

7 = turn to read (8 positions)

Type of connection

A = threaded connections for inline mounting

Type code

Modification number

Supplementary details

V = Viton seals

12 = 7/16 x 20 UNF - MS 4/5

2.1.3 Mounting method

Flange mounting

4 screws M 6 ISO 4762

2.1.4 Connections

MS 2/MSL 2/MS 4/MS 5

G 1/4 (ISO 228)

MS 6/MS 7

G 1/8 (ISO 228)

MS 2/MSL 2

6 measuring points

1 tank connection

MS 4/MS 6

6/9 measuring points

1 gauge connection = M

1 tank connection = T

MS 5/MS 7

5/8 measuring points

1 gauge connection = M

1 tank connection = T

1 leakage connection = L

2.1.5 Weight

MS 2/MSL 2: 1.7 kg

MS 4/MS 5: 1.4 kg

MS 6/MS 7: 1.9 kg

2.1.6 Mounting position

Optional

2.1.7 Operating fluid

Mineral oil to DIN 51524

and DIN 51525

Special fluids on request.

2.2. HYDRAULIC TECHNICAL DATA

2.2.1 Operating pressure range

MS 2/MSL 2

Max. permitted operating pressure at measuring points 1 to 6: depending on permitted indicator range of gauge

= p_{max} up to 315 bar

Tank connection = p_{max} 10 bar.

MS 4/MS 5/MS 6/MS 7

Max. permitted operating pressure at the measuring points

= p_{max} 315 bar

Tank connection and leakage connection = p_{max} 10 bar.

2.2.2 Temperature range of operating medium

-20 °C... +70 °C

2.2.3 Gauge accuracy

MS 2/MSL 2

The accuracy of the built-in gauge is 1.6% of the red scale value at 20 °C. Inaccuracy per 10 °C temperature increase approx. +0.3% and per 10 °C temperature decrease approx. -0.3% of the red scale value.

3. DIMENSIONS

TYPE MS 2

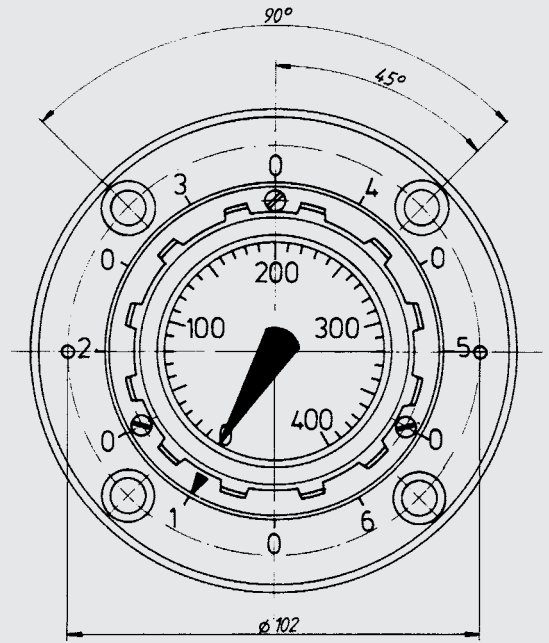
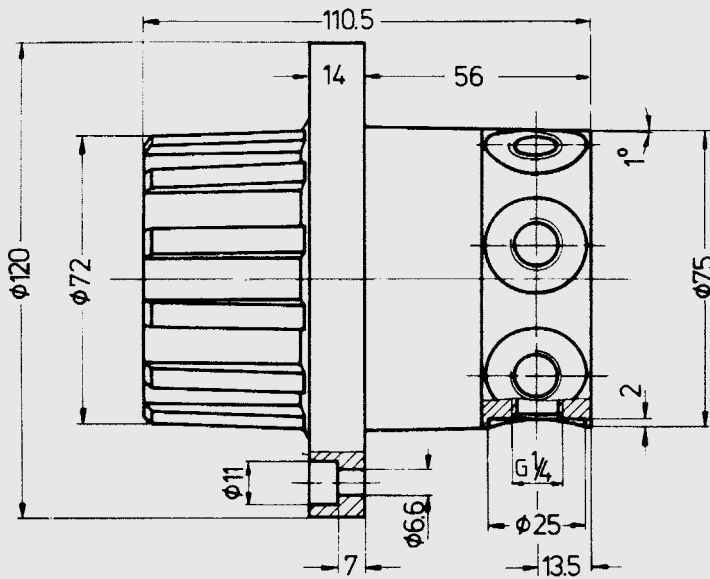

TYP MSL 2

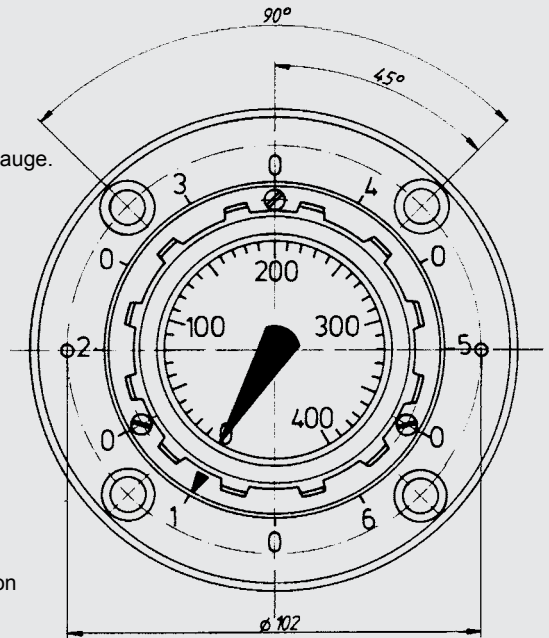
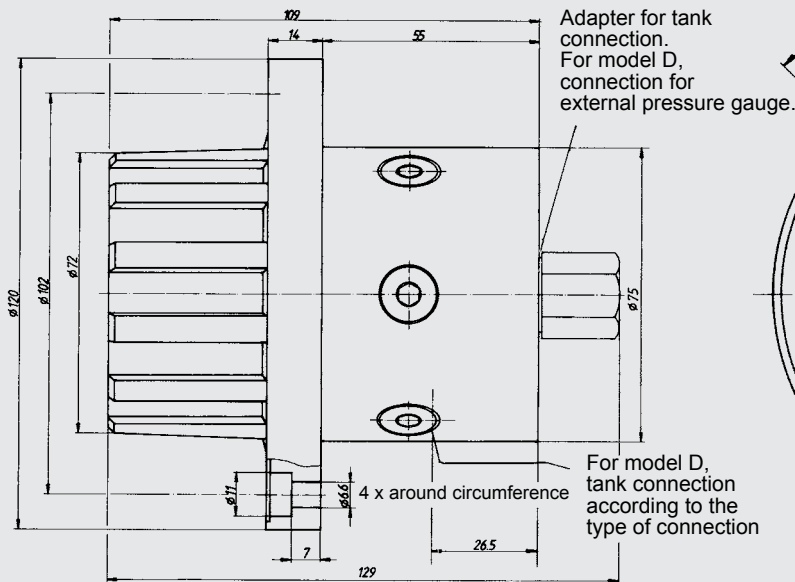

Type of connection:
A/G/H

Connections:

A

G

H

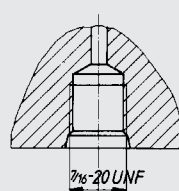
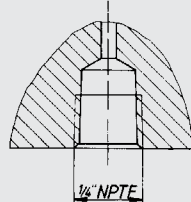
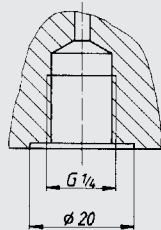
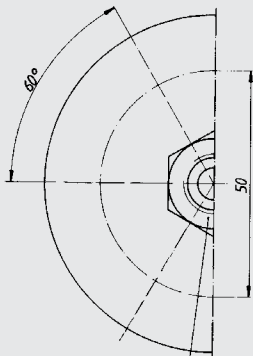

Adapter
for tank connection.
For model D,
connection for external
pressure gauge

TYPE MS 4

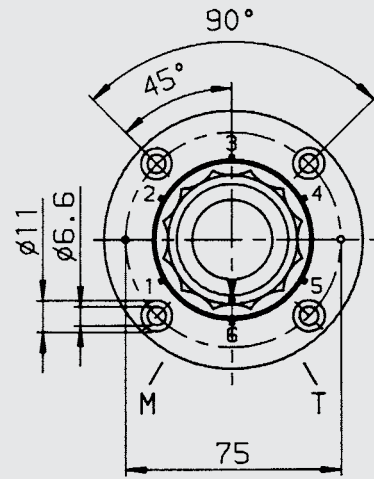
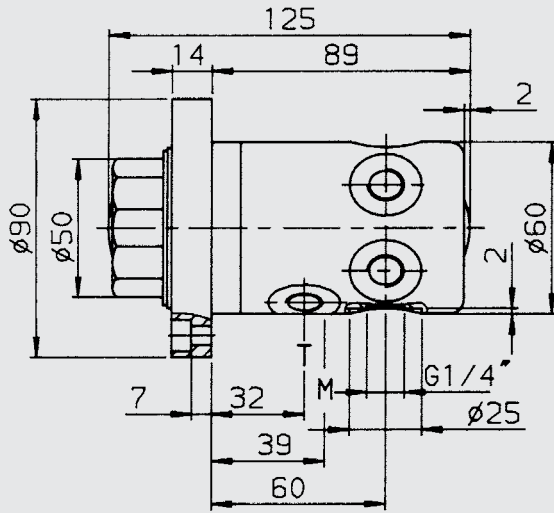

TYPE MS 5

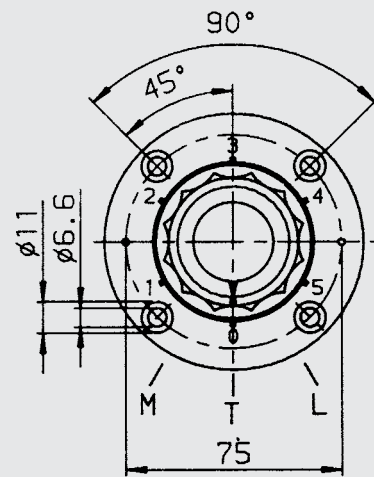
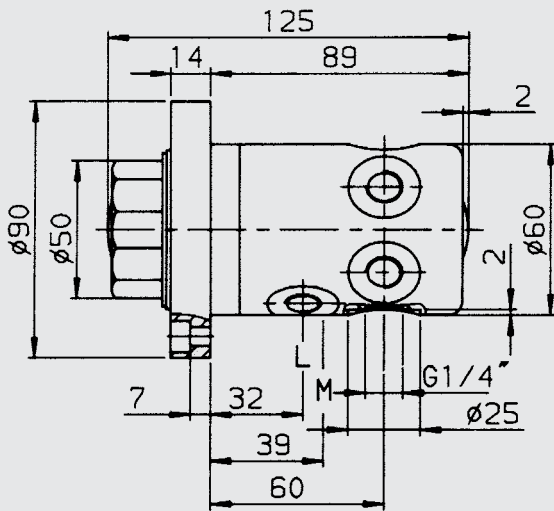

TYPE MS 6

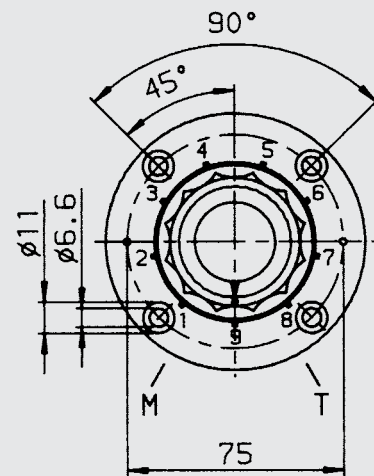
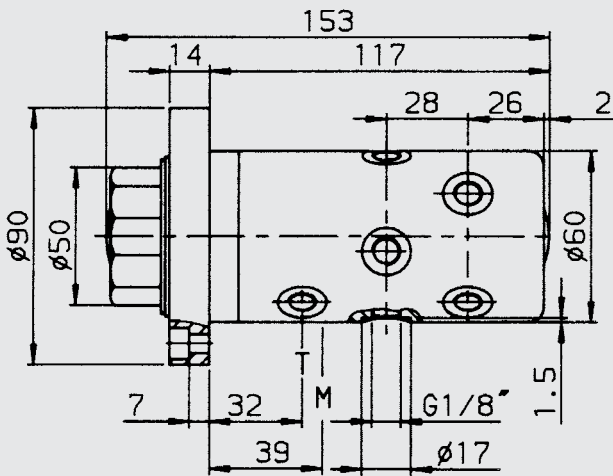

TYPE MS 7

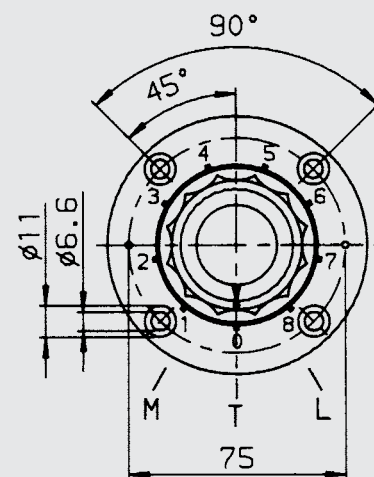
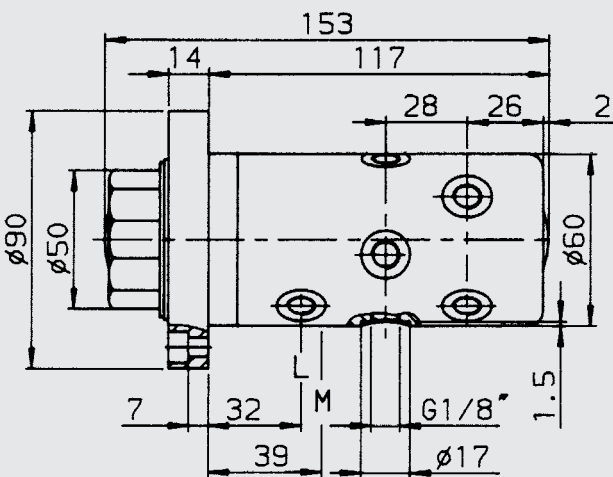

4. SPARE PARTS MS 2

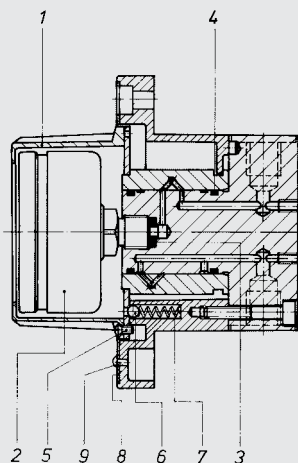

Item	Qty.	Description
1	1	Rotary knob
2	1	Gauge
3	1	Seal ring
4	2	Quad rings
5	3	Slotted head screws M3 x 6 DIN 964 - 5.8
6	1	Ball 5 mm DIN 5401 Class III
7	1	Spring
8	1	Scale plate
9	2	Rivets 2 x 6 DIN 1476

ORDER EXAMPLE

Type MS 2 A 2 . 0 / 315 .

1 off seal ring, item 3

(When ordering, always quote the whole model code of the unit)

SPARE PARTS MSL 2

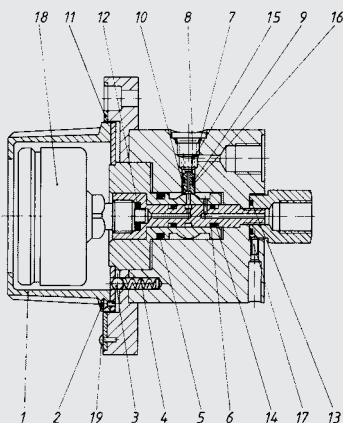

Item	Qty.	Description
1	1	Rotary knob
2	3	Slotted head screws M 3 x 5 DIN 964
3	1	Ball 5 mm DIN 5401 Class III
4	1	Spring
5	1	O-ring 15 x 2.5
6	2	O-ring 6 x 2
7	6	O-ring 8.5 x 1.5
8	6	Locking screws G 1/8 DIN 908
9	6	O-ring 2 x 1.6
10	6	Seals
11	1	Scale plate
12	1	Seal ring
13	1	O-ring 9.25 x 1.78
14	2	Support rings
15	6	Springs
16	6	Support rings
17	1	Grub screw M 4 x 10 DIN 914
18	1	Pressure gauge
19	2	Rivets 2 x 6 DIN 1476

ORDER EXAMPLE

Type MSL 2 A 2 . 0 / 315 .

1 off seal ring, item 12

(When ordering, always quote the whole model code of the unit)

SPARE PARTS MS 4

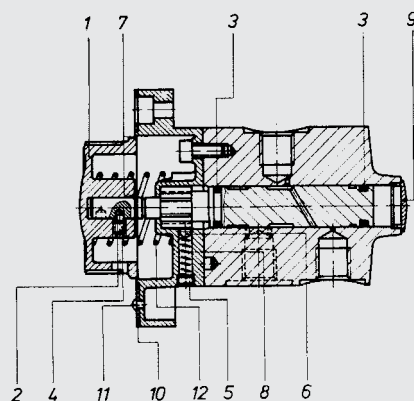

Item	Qty.	Description
1	1	Rotary knob
2	1	Disc
3	2	Quad rings
4	1	Grub screw M 5 x 8 DIN 417
5	1	Grub screw M 6 x 4 DIN 557
6	1	Ball 5 mm DIN 5401 Class III
7	1	Retainer 8 x 0.8 DIN 471
8	1	Spring
9	1	End cap
10	1	Scale plate
11	2	Rivets 2 x 6 DIN 1476
12	1	Spring

ORDER EXAMPLE

Type MS 4 A 2 . 0 / .

1 off quad ring item 3

(When ordering, always quote the whole model code of the unit)

SPARE PARTS MS 5

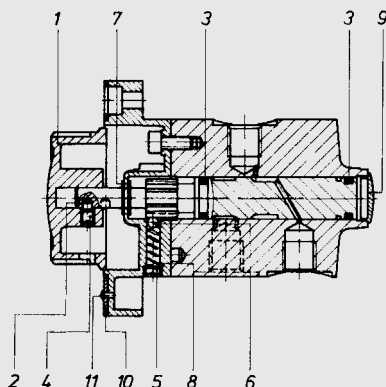

Item	Qty.	Description
1	1	Rotary knob
2	1	Disc
3	2	Quad rings
4	1	Grub screw M 5 x 8 DIN 417
5	1	Grub screw M 6 x 4 DIN 557
6	1	Ball 5 mm DIN 5401 Class III
7	2	Retainers 8 x 0.8 DIN 471
8	1	Spring
9	1	End cap
10	1	Scale plate
11	2	Rivets 2 x 6 DIN 1476

ORDER EXAMPLE

Type MS 5 A 2 . 0 / .

1 off quad ring, item 3

(When ordering, always quote the whole model code of the unit)

SPARE PARTS MS 6

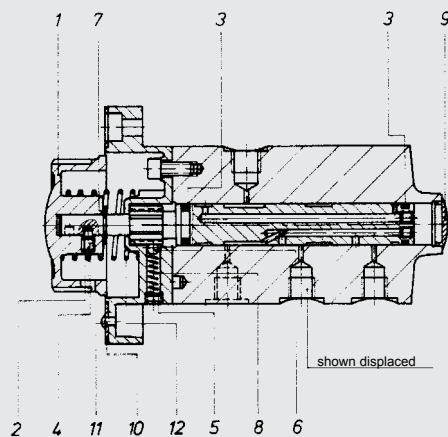

Item	Qty.	Description
1	1	Rotary knob
2	1	Disc
3	2	Quad rings
4	1	Grub screw M 5 x 8 DIN 417
5	1	Grub screw M 6 x 4 DIN 557
6	1	Ball 5 mm DIN 5401 Class III
7	1	Retainer 8 x 0.8 DIN 471
8	1	Spring
9	1	End cap
10	1	Scale plate
11	2	Rivets 2 x 6 DIN 1476
12	1	Spring

ORDER EXAMPLE

Type MS 6 A 2 . 0 / .

1 off quad ring, item 3

(when ordering, always quote the whole model code of the unit)

SPARE PARTS MS 7

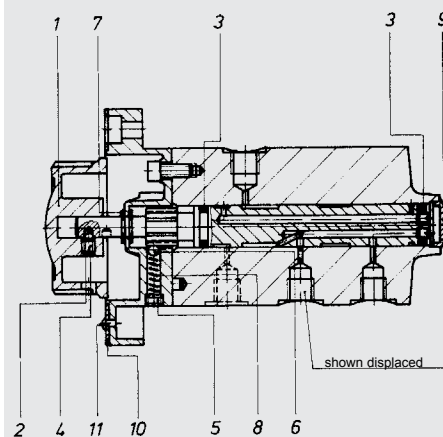

Item	Qty.	Description
1	1	Rotary knob
2	1	Disc
3	2	Quad rings
4	1	Grub screw M 5 x 8 DIN 417
5	1	Grub screw M 6 x 4 DIN 557
6	1	Ball 5 mm DIN 5401 Class III
7	2	Retainers 8 x 0.8 DIN 471
8	1	Spring
9	1	End cap
10	1	Scale plate
11	2	Rivets 2 x 6 DIN 1476

ORDER EXAMPLE

Type MS 7 A 2 . 0 / .

1 off quad ring item 3

(When ordering, always quote the whole model code of the unit)

MOUNTING INSTRUCTIONS

Taking into account the operating forces, it is recommended that measuring points with pressures of more than 100 bar are arranged symmetrically. Ports not required should be plugged.

Required oil cleanliness class for MSL:
NAS 1638-9 ISO DIS 4406-18/14

NOTE

The information in this brochure relates to the operating conditions and applications described. For applications or operating conditions not described, please contact the relevant technical department. Subject to technical modifications.

HYDAC Accessories GmbH

Hirschbachstr. 2

66280 Sulzbach/Saar

Tel.: +49 (0)6897 - 509-01

Fax: +49 (0)6897 - 509-1009

Internet: www.hydac.com

E-Mail: info@hydac.com