



Nominal voltage: 9 – 36 V

Nominal current: 0 – 2,000 mA PWM  
0 – 3,000 mA on/off

## SMART-Series Controller

### Joystick Controller

#### G-pro

#### Table of content

Product features	2
General information and functional description	2
Technical data	3
G-pro components and specification	4
Installation, usage and maintenance information	6
Dimensions	7
G-pro accessories	8
G-pro smart system packages and configuration examples	10



## Product features

- Integrated PWM and on/off outputs
- Innovative ergonomic design
- Flexible installation
- Configurable
- Adjustable parameters
- Built in error diagnostics

## General information and functional description

The G-pro is a joystick controller for operators input and direct current activation for various machine functions controlled via electro-hydraulic valves. Proportional functions and on/off functions can be operated.

A power feed obtained from vehicle's voltage source is the only connection needed aside from the internal system connection between G-pro controller and valve(s).

Pre-defined, pre-installed and pre-set firmware enables use in many generic applications. Some configurations for specific applications are prepared. For example special constraints for activation of a specific function where possibility for unintended activation must be eliminated.

The PWM outputs are current controlled which enables exact control independent of influences from temperature etc.

- Regulated PWM current
- Redundant input components – safety level PLC
- Plug and work with pre-defined firmware

Built in error diagnostics indicates error codes for internal errors as well as for external errors, such as short circuit electrical wire or open load.

The G-pro system covers not only the main controller, but also the surrounding items to form the complete installation between cabin and valve.

The controller's main parameter settings can be adjusted via USB interface and a PC software tool. This enables optimization for machine and operator needs. Min/max current, acceleration/retardation ramps and PWM frequency are the available standard parameters.

G-pro is compliant with basically all mobile valves in electro hydraulic config. Examples: RSQ 240, RS 220 , DX-6, LX-6, RS 160, RMX 202.

## Overview

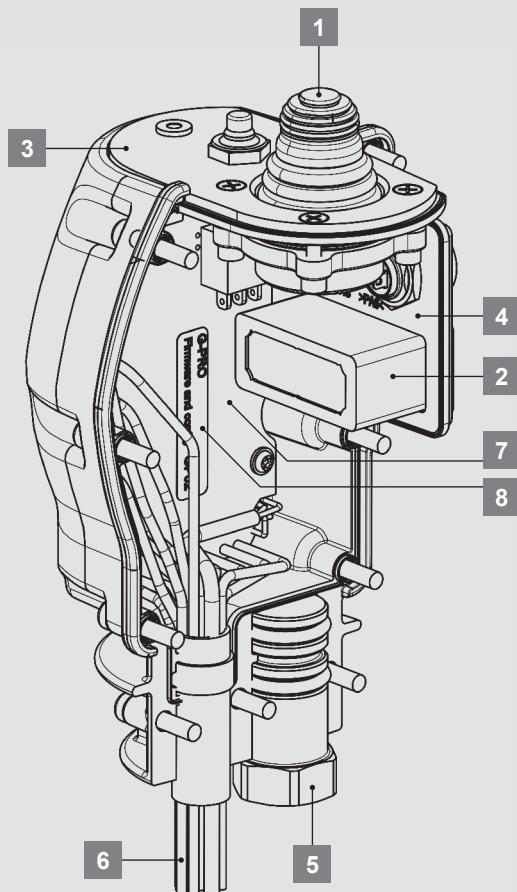

- |   |   |
|---|---|
| 1 | Thumb joystick – for dual axis prop. input                    |
| 2 | Horizontal roller – for single axis input                     |
| 3 | Top plate (multiple configurations)                           |
| 4 | Rear plate (multiple configurations)                          |
| 5 | Attachment part (M10x1.5, threaded depth 15 mm)               |
| 6 | Integrated harness for power feed and outputs + USB           |
| 7 | Electronics with internal input channels and external outputs |
| 8 | Pre-installed and pre-set firmware (multiple configurations)  |

## Technical data

### General data and operating conditions

Controller dimensions	152 x 87 x 83 mm
Weight	~190 g
Outputs (PWM)	6 x PWM Out (or digital) up to 2A, current measurement, overload and open load detection
PWM frequency	100 – 250 Hz (adjustable)
Outputs (dig)	3 x digital out, up to 3 A, overload and open load detection
Inputs	N/A (only internal inputs: 5 buttons, 6 analogue-prop)
Supply voltage	9 – 36 V (pre-configured for 12 or 24 V system voltage)
Max idle current	68 mA
Total load current	13 A
Connector	13 pcs crimped connector pins type 1060-16-0122 for Deutsch connectors (several series)
Mechanical life (j-stick)	At max load 120 N, 60.000 cycles – at normal operation force ~ 3.1 N > 1,000,000 cycles
Operating temperature	-30 °C to +65 °C
Ingress Protection	N/A (for cabin installations only)
Interface for parameter adjustments	USB micro B (female) at ~100 mm USB cable extension from encapsulation
Software	Fixed application firmware pre-installed from factory. Parameter settings tool for adjustment of currents, ramps and PWM frequency available as separate item.

### Environmental data

Functional safety	Designed for ISO 13849 PLC
Mechanical (vibration)	IEC 60068-2-64 test Fh
Mechanical (shock)	IEC 60068-2-27 test Ea
Low temp test	IEC 60068-2-1
High temp test	IEC 60068-2-2
Temp/humidity test	IEC 60068-2-38 test Z/AD
Temp change test	IEC 60068-2-14 test NB
EMC - radiated emission	EN13309 (ESA test method)
EMC -transient emission	ISO 7637-2
EMC-RF electromagnetic field	ISO11452-2
EMC-bulk current injection (BCI)	ISO 11452-4
EMC-ESD	ISO 10605
Ingress Protection	N/A (for cabin installations only)
EMC- conducted transients	ISO7637-2

### Misc. data

CE mark	Designed for ISO 13849 PI C
E-mark	IEC 60068-2-64 test Fh
Input components	Ingress protection IP67 (button,roller) IP68 (joystick). Joystick and roller with dual hall sensors
Recommended compliant connectors	Deutsch DT-series, HD30-series, HDP20-series
USB protocol	Full speed (12Mb/s)
Error indication	By LED flashing code

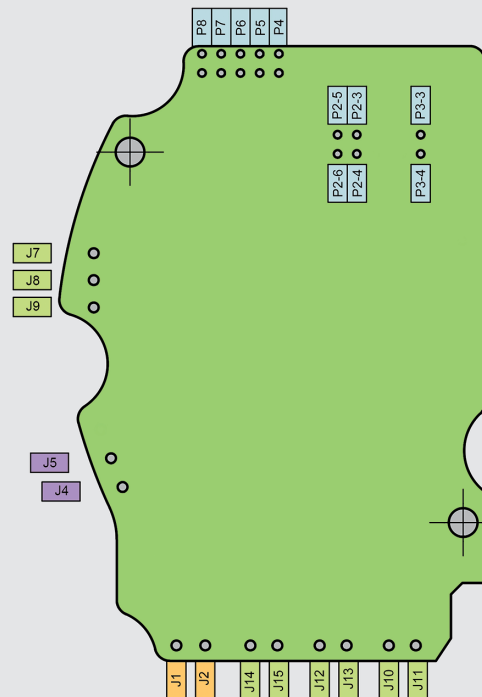

<b>Conductor</b>	J10	J11	J12	J13	J14	J15
<b>Output (PWM)</b>	PWM1A	PWM1B	PWM2A	PWM2B	PWM3A	PWM3B

<b>Conductor</b>	J7	J8	J9
<b>Output (Dig)</b>	D1	D2	D3

<b>Internal Inputs</b>	P4	P5	P6	P7
<b>Components / channel</b>	Button1	Button3	Button3	Button4
	P8	P2-3	P2-4	P2-5
	Button5	Joy-#2X	Joy-#1X	Joy-#2Y
	P2-6	P3-3	P3-4	
	Joy-#1Y	Roll-#1	Roll-#2	

<b>Conductor</b>	J1	J2	J3
<b>Power feed</b>	+	GND	IGN

<b>Conductor</b>	J4	J5
<b>Slave / Master</b>	Slave input	Master output

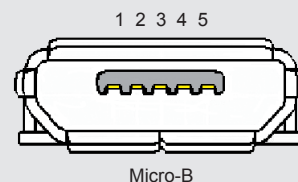

## G-pro components and specification

### Main controller specifications

	Hardware config						Firmware selection	Default parameter setting
Code example	G	R	W	2	0	Y	3	1
Notes	G-pro	Right/ left hand	Rear plate bottom row	Rear plate top row	Top plate	Top plate LED	Firmware option	Parameter option
Selections	G	R  L	W (finger wheel) 1 (1 push button) 2 (2 push buttons)	0 (no push button) 1 (1 push button) 2 (2 push buttons)	0 (no push button) 1 (1 push button) 2 (2 push buttons)	R (red)  Y (red + yellow)	1 (front loader) 2 (generic) 3 (generic unloading) 4 (generic float) 5 (front hitch) 6 (24 V front hitch std)	1 (12 V generic std) 2 (24 V generic std) 3 (12 V front loader std) 4 (24 V front loader std) 5 (12 V front hitch std) 6 (24 V front hitch std)



### Main controllers



#### Right hand controller for generic applications

##### GRW20R31

- X-Y joystick for proportional control of 4 PWM outputs
- Roller/wheel for proportional control of 2 PWM outputs
- 2 buttons for on/off momentary control of 2 digital outputs
- Special unloading valve control feature by a third on/off output
- Master output for remote activation of left hand controller
- Factory settings:  
12 V version: starting point 500 mA for 12 V, 250 mA for 24 V, max. current 1,200 mA for 12 V, 600 mA for 24 V, PWM ramps up/down 300 ms, PWM frequency 130 Hz

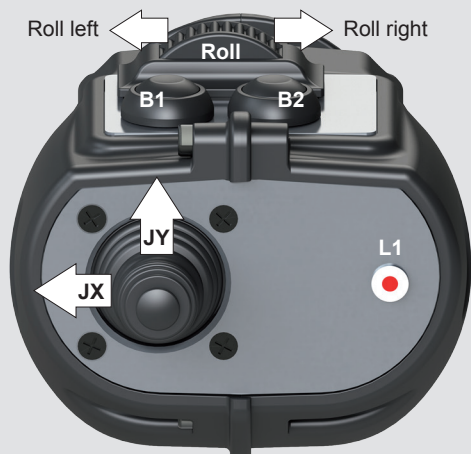

### Left hand controller for generic applications

#### GLW20R31

- X-Y joystick for proportional control of 4 PWM outputs
- Roller/wheel for proportional control of 2 PWM outputs
- 2 buttons for on/off momentary control of 2 digital outputs
- Special unloading valve control feature by a third on/off output
- Slave input for remote activation from right hand controller.  
**Please note:**  
GL1 is not intended as a single controller
- Factory settings:  
12 V version: starting point 500 mA for 12 V, 250 mA for 24 V, max. current 1,200 mA for 12 V, 600 mA for 24 V, PWM ramps up/down 300 ms, PWM frequency 130 Hz

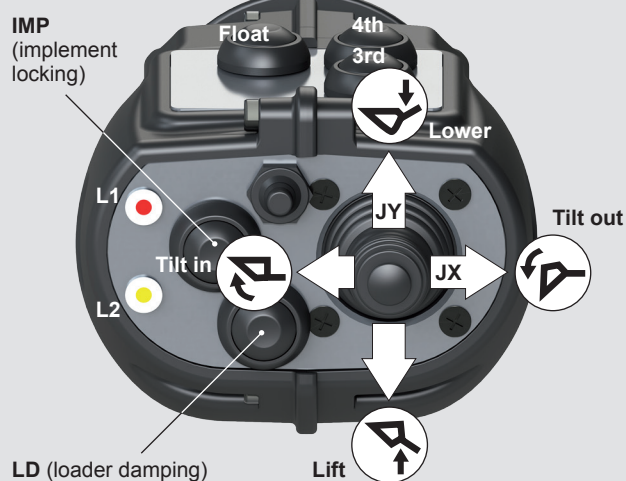

### Right hand controller for front loader application

#### GR212Y11

- X-Y joystick for proportional control of 4 PWM outputs
- 2 buttons for on/off momentary control of 2 digital outputs (3<sup>rd</sup>, 4<sup>th</sup> function)
- 1 button for on/off toggle control of 1 digital output (loader damping)
- Special float mode feature for combination with RMX 202 valve
- Special implement locking activation feature – control of 1 digital output
- Extra indicator LED (yellow) for different mode indication (float, imp. lock)
- Factory settings:  
12 V version: starting point 500 mA for 12 V, 250 mA for 24 V, max. current 1,000 mA for 12 V, 500 mA for 24 V, PWM ramps up/down 300 ms, PWM frequency 200 Hz

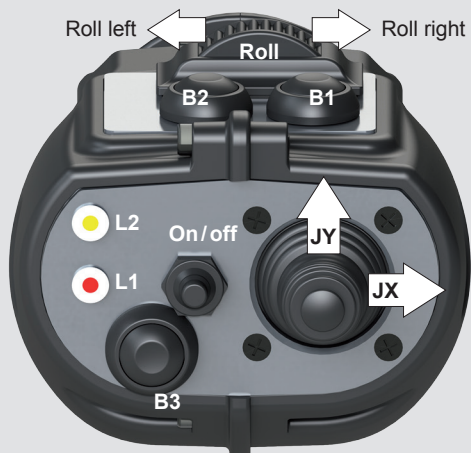

### Right hand controller for generic applications

#### GRW21Y41

- X-Y joystick for proportional control of 4 PWM outputs
- 2 buttons for momentary on/off control of 2 digital outputs (D1, D2)
- 1 button for on/off toggle control of 1 digital output (D3 for as example float mode)
- Extra indicator LED (yellow) for indication of the toggle on/off of output D3)
- Factory settings:  
Starting point 500 mA for 12 V, 250 mA for 24 V, max. current 1,200 mA for 12 V, 600 mA for 24 V, PWM ramps up/down 300 ms, PWM frequency 130 Hz

## Installation, usage and maintenance

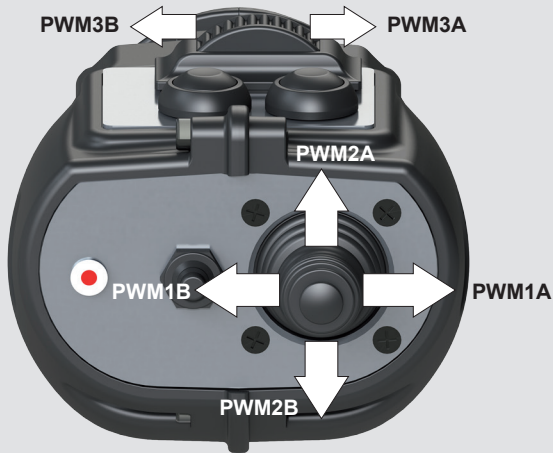

Activation	Output
Joystick right / left	PWM1A / PWM1B
Joystick forward / backwards	PWM2A / PWM2B
Roller right / left	PWM3A / PWM3B
Button B1 / B2	D1 / D2

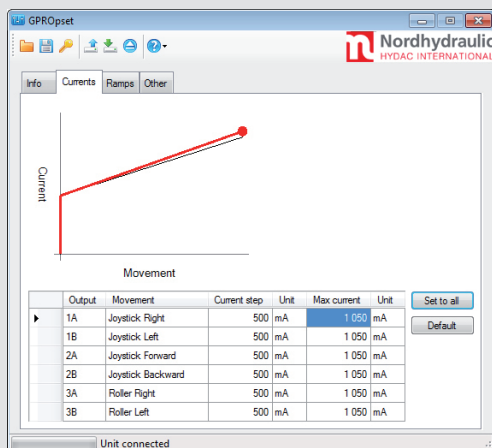

### Installation

Starts at the operator's seat and control panel(s).

### Position

A suitable position is chosen. Both ergonomic and practical aspects need to be considered. When the controller(s) are positioned the electrical harnesses are routed.

### Routing

When routing all electrical wiring, ensure that it is well protected from wear and impact damages. The integrated harness of the controller joystick needs to be rigorously protected. Extra protection material (cable sleeves etc.) should be added if it is not possible to route behind panels or similar.

Protection of the integrated harness is a safety consideration.

### Supply connection

Power feed harnesses need adaptation to fit towards vehicle's power supply terminal. Use proper crimp tools and crimp terminal material. The voltage source must be stable and can supply at least 10 A current. Ensure that the grounding point is solid.

One single grounding point shall be used for the entire system; all coil loads shall be grounded through the same grounding point as the main controller's grounding point.

The power feed + conductor have an inline fuse (15 A) that should be accessible for later replacement.

### Valve connection

The harness towards valve is now routed and connection to the valve is completed according to the specific valve configuration and intention of the control.

As the valve configurations and applications may vary it is not possible to present a general connection schematic for the generic versions. The output mapping of the controllers and the corresponding output marking of harnesses at the valve connection side are common for these controllers and harnesses.

In "dual hand applications" using two controllers and dual harnesses it is recommended to add a color marking to all connectors of one of the harnesses (example: the right hand controller's harness connectors are all marked with green color label markings). This way the duplicate output markings of two identical harnesses will be identified by the added marking.

### Fine tuning

All G-pro controllers are able to be fine tuned using the parameter settings tool. Parameters such as current step, max. current, ramp up, ramp down and PWM frequency may be modified.

By the software tool P-SET, currents and ramps can be set individually for each PWM output. The settings can be saved to local files on a computer.

The help section of the program includes all instructions to operate the program and how to make basic settings.

## Dimensions

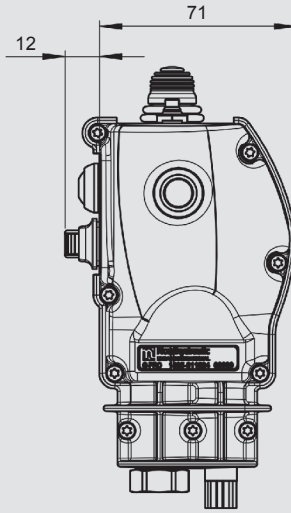
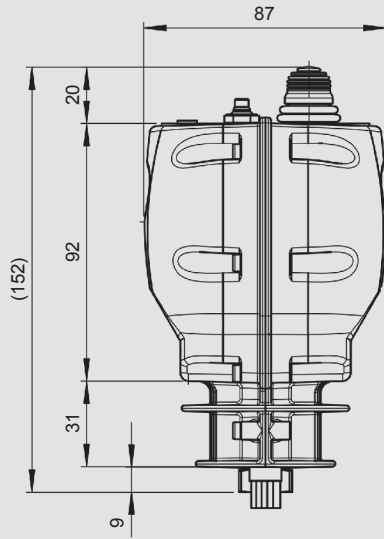

Length of integrated harness  
Is ~950 mm (cropped in drawing views)

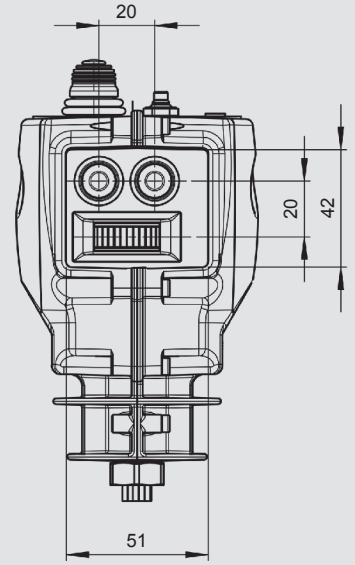

Weight: ~190 g  
(GRW20R31 config)

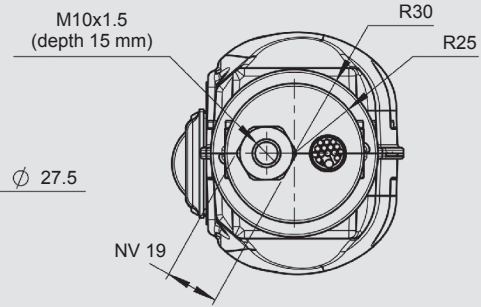
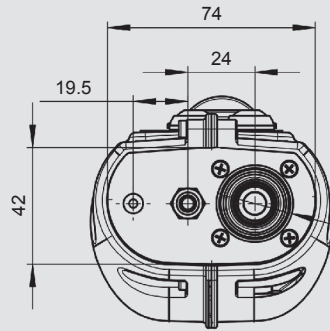

## G-pro accessories

### Brackets

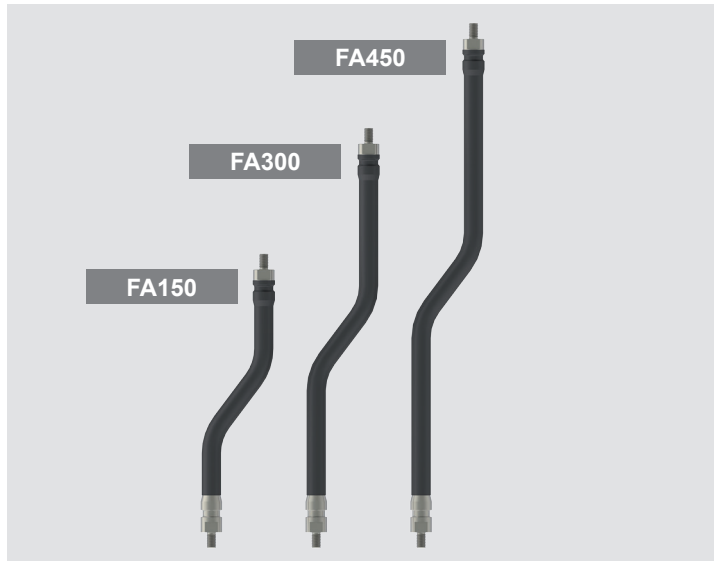

#### Brackets

##### FA...

The universal flex arm option offers easy installation in tight cabin environments.

The adjustable positioning of the controller unit enables an individual ergonomic setup. Three lengths available as standard option: 150, 300 and 450 mm.

When not used the controllers can be folded away to free space for other operations.

Possibility for other different bracket- or fitting solutions for the customers unique conditions are enabled by the robust and basic design of the controller units bracket interface.

Two rigid bracket solutions examples are T-bar mount and panel mount (these may vary from case to case so there are no such general options presented).

### Connector kits

The controller units all come with an integrated harness (L ~ 950 mm) and prepared with crimped terminal pins for commodity connectors of brand Deutsch. Several connector models uses the same type of pin and socket terminals.

To form the interface towards valve and power feed harness items, a separate connector kit is needed to be added to the controller unit's integrated harness.



##### G01

Recommended for static installations where the connection to valve harness is not frequently disconnected (suitable mating valve harness is VG1).

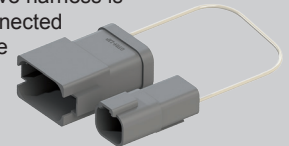

##### G02

Recommended for installations where the connection to valve harness is frequently disconnected. Comes with 1.5 M cabin extension harness and a more rigid chassis connector towards valve harness (suitable mating valve harness is VG2).



##### CHDT0412

Connector housing for front loader controller and front loader valve harness (VFL1).



### Install accessories



#### Nitrile bellows

##### B01

Nitrile bellows for G-pro with flex arm installation option.

Covers the transition between controller unit and flex arm.



## Valve harnesses

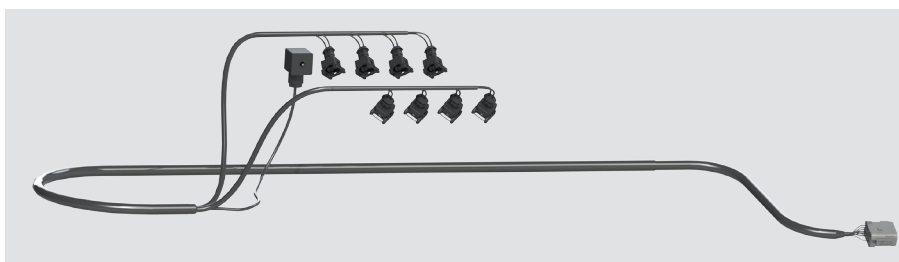

**VG1**

For generic applications and static installations. 9x AMP junior timer connectors for 4 sections and one unloading valve. PVC insulated conductors with PVC protective hose up to split point near valve location. Length 4.5 m.

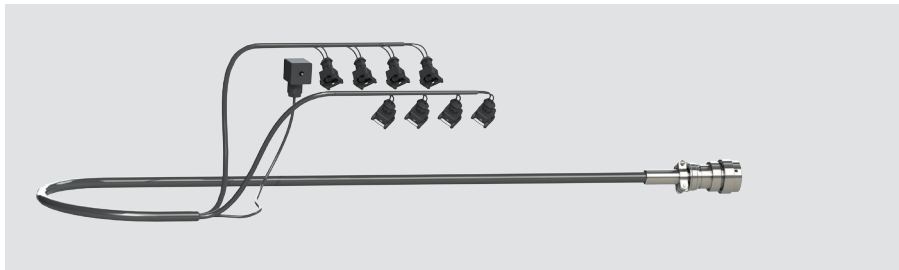

**VG2**

For generic applications where the valve harness needs to be frequently disconnected (example: forestry crane wagon installations). Same length and valve connectors as VG1 but with a chassis connector towards cabin and controller.

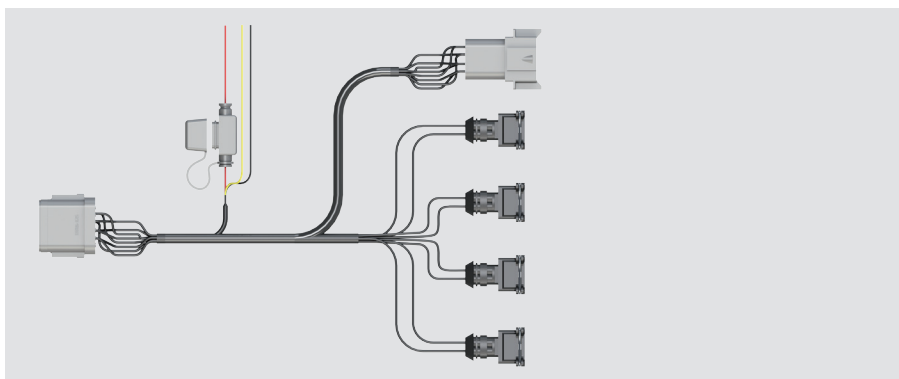

**VFL1**

For front loader application. 4x AMP junior timer connectors for 2 sections main valve and 1x DT06 8pole connector towards additional harness to selector valve and implement locking valve. Power feed part integrated via split in harness. 15A fuse included. Total length 4.5 m.

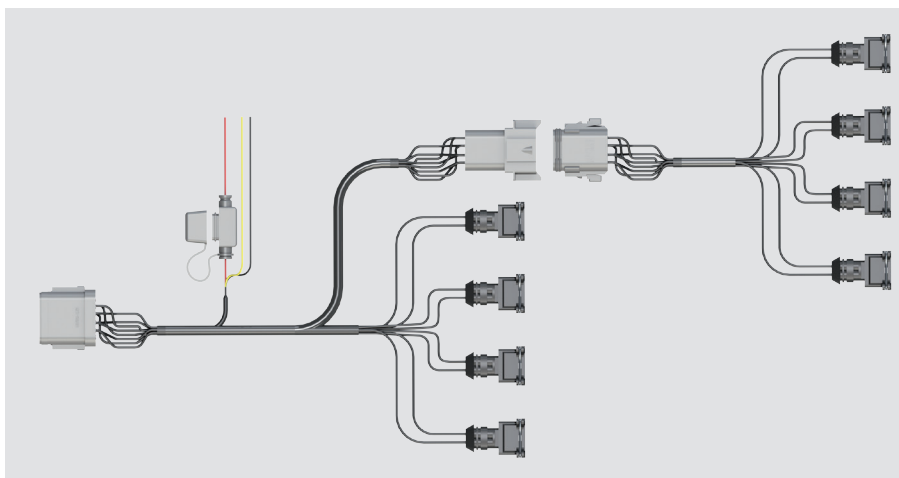

**FLC1**

For front loader application. Combo with VFL1 (above) and an included extension for routing onto front loader towards selector valve. 4x AMP junior timer connectors for 2 sections main valve and 4 x AMP junior timer connectors for selector valve functions 3:rd/ 4:th, loader damping and implement locking valve. Length 4.5 + 4.5 m.

## Common system items



**PFG1**

Power feed harness for generic applications. For vehicle system voltage feed to 1 or 2 controllers. 15 A fuse included. Length 1.5 m.



**MSTK**

Crimp terminals to be installed onto master and slave conductors of controller units integrated harnesses. To use in dual hand applications using two controllers. Enables remote startup and shutdown of the left hand controller via the right hand controllers on/off button.

## G-pro smart system packages and configuration examples

The G-pro system can be configured to different applications and machines.

The basic configuration principle is use of pre-defined system items that in a configured combination contain all parts needed for installation towards one or several hydraulic valves. A complete system is defined by a type code string.

See the example below for a typical forestry crane application which includes dual controller units.

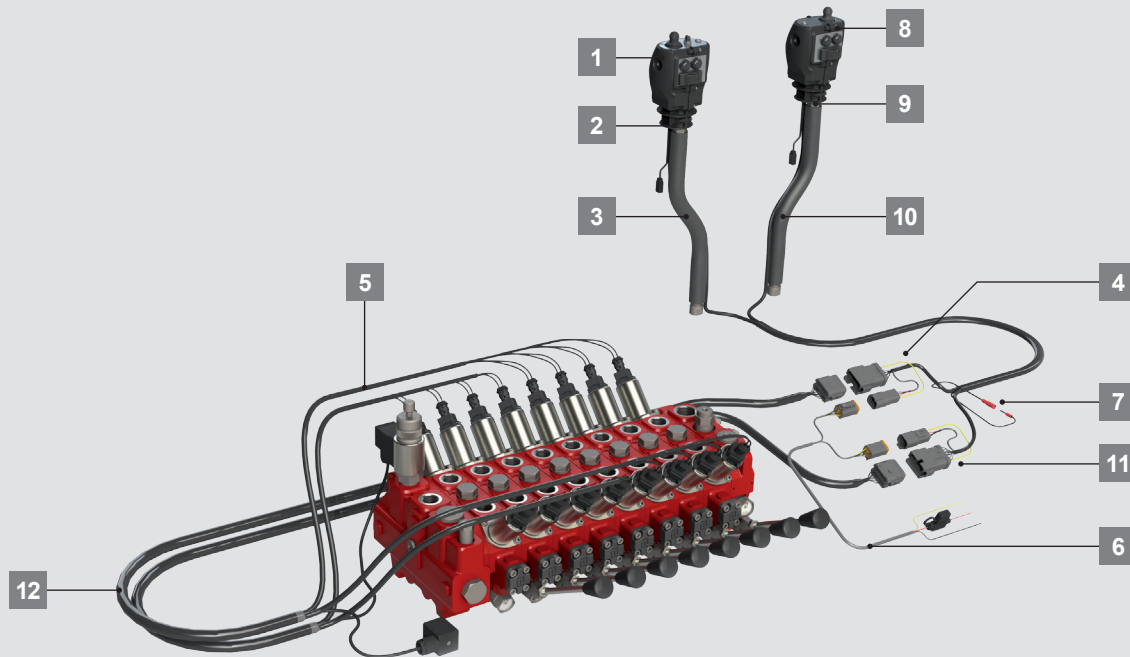

### Type code structure

Example: Smart universal control for multipurpose use

Complete system items											
Right hand controller items					Common system items		Left hand controller items				
1	2	3	4	5	6	7	8	9	10	11	12
Main controller (right hand)	Install accessorie	Bracket type	Connector kit	Valve harness	Power feed harness	Master/ slave connection	Main controller (left hand)	Install accessorie	Bracket type	Connector kit	Valve harness
GRW20R31-	B01-	FA300-	G01-	VG1-	PFG1-	MSTK-	GLW20R31-	B01-	FA300-	G01-	VG1-
GRW20R31-B01-FA300-G01-VG1							GLW20R31-B01-FA300-G01-VG1				
GRW20R31-B01-FA300-G01-VG1-PFG1-MSTK-GLW20R31-B01-FA300-G01-VG1											

Main controller (right hand)	1.1	Main controller GRW20R31	Valve harness	5.1	VG1 Generic harness L 4.5M
	1.2	Main controller GRW21Y41		5.2	VG2 trailer harness L 4.5M
	1.3	Main controller GR212Y11		5.3	VFL1 front loader harness
Install accessories	2.1	Bellows B01	Power feed harness	6.1	Harness PFG1
	2.2	– (none)		6.2	– (none)
Bracket type	3.1	Flex arm L150	Master slave connection	7.1	Terminal kit MSTK
	3.2	Flex arm L300		7.2	– (none)
	3.3	Flex arm L450	Main controller (left hand)	8.1	Main controller GLW20R31
	3.4	– (none)		8.2	– (none)
	3.5	– (none)		<b>Left hand controller items (besides main controller):</b>	
Connector kit	4.1	Connector kit G01	Install accessories	9	– see list under 2
	4.2	Connector kit G02	Bracket type	10	– see list under 3
	4.3	Connector housing CHDT0412	Connector kit	11	– see list under 4
	4.4	– (none)	Valve harness	12	– see list under 5

## Example: Smart universal control for front loader and front hitch applications

System with a 2 sectional proportional directional valve and an on/off selector valve.

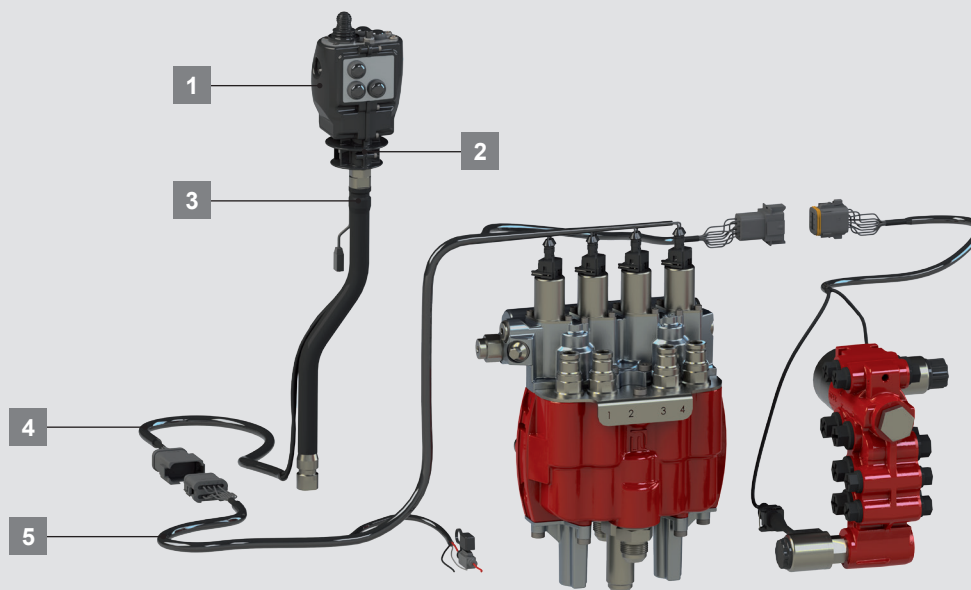

### Type code structure

Complete system items												
Right hand controller items					Common system items		Left hand controller items					
1	2	3	4	5	6	7	8	9	10	11	12	
Main controller (right hand)	Install accessorie	Bracket type	Connector kit	Valve harness	Power feed harness	Master/ slave connection	Main controller (left hand)	Install accessorie	Bracket type	Connector kit	Valve harness	
GR212Y11-	-	FA300-	CHDT0412-	FLC1-	-	-	-	-	-	-	-	
GR212Y11-FA300-CHDT0412-FLC1							GR212Y11-FA300-CHDT0412-FLC1					
GR212Y11-FA300-CHDT0412-FLC1												

Main controller (right hand)	<b>GR212Y11</b>	Main controller for 4 PWM and 4 on/off functions, special features float and implement locking
Install accessories	-	(none)
Bracket type	<b>FA300</b>	Flex arm attachment between controller and cabin
Connector kit	<b>CHDT0412</b>	Connector housing for terminating controllers integrated conductors that comes un-terminated
Valve harness	<b>FLC1</b>	Combo item with two harnesses for power feed and main valve connection + connection to selector valve
Note: separate power feed harness, see code pos. 6, is not needed where this item is chosen		

## Note

The information in this brochure relates to the operation conditions and applications described.

For applications and operating conditions not described, please contact the relevant technical department.

Subject to technical and other changes. This document is a draft of an ongoing work to create a final data sheet.



**Nordhydraulic**  
HYDAC INTERNATIONAL

Head Office  
HYDAC INTERNATIONAL  
GMBH

Industriegebiet  
66280 Sulzbach/Saar  
Germany

Tel.: +49 6897 509-01  
Fax: +49 6897 509-300

E-mail: [mobilevalves@hydac.com](mailto:mobilevalves@hydac.com)  
Internet: [www.hydac.com](http://www.hydac.com)