

Open-Center Sectional Directional Control Valve RS 160-EH

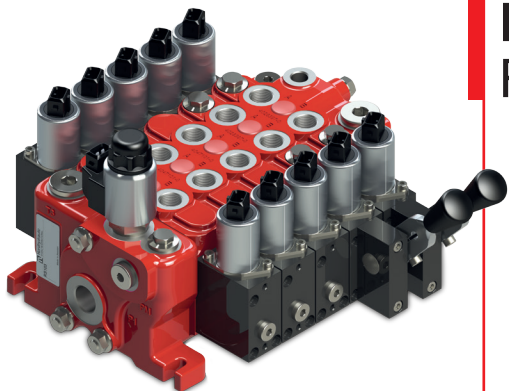

Max. pressure: 250 bar
 Max. flow rate
 ● Pump port: 60 l/min
 ● Working ports: 60 l/min

Table of contents

Product features	2
General information and functional description	2
● Overview	2
Technical data	4
Characteristic curves	5
Modular structure	6
Example of block specification and type code	7
Inlet plates	8
● Inlet plate P15	8
● Inlet plate U15	9
Working sections	10
● Section types	10
● Spools	11
● Working port valves	13
● Operation units	14
End plates	15
Solenoid valves and coils	16
Connection type, fastening and tie rods	17
Installation, usage and maintenance information	17
Interconnection examples	18
Dimensions	19
Type code	22
Ordering examples	25

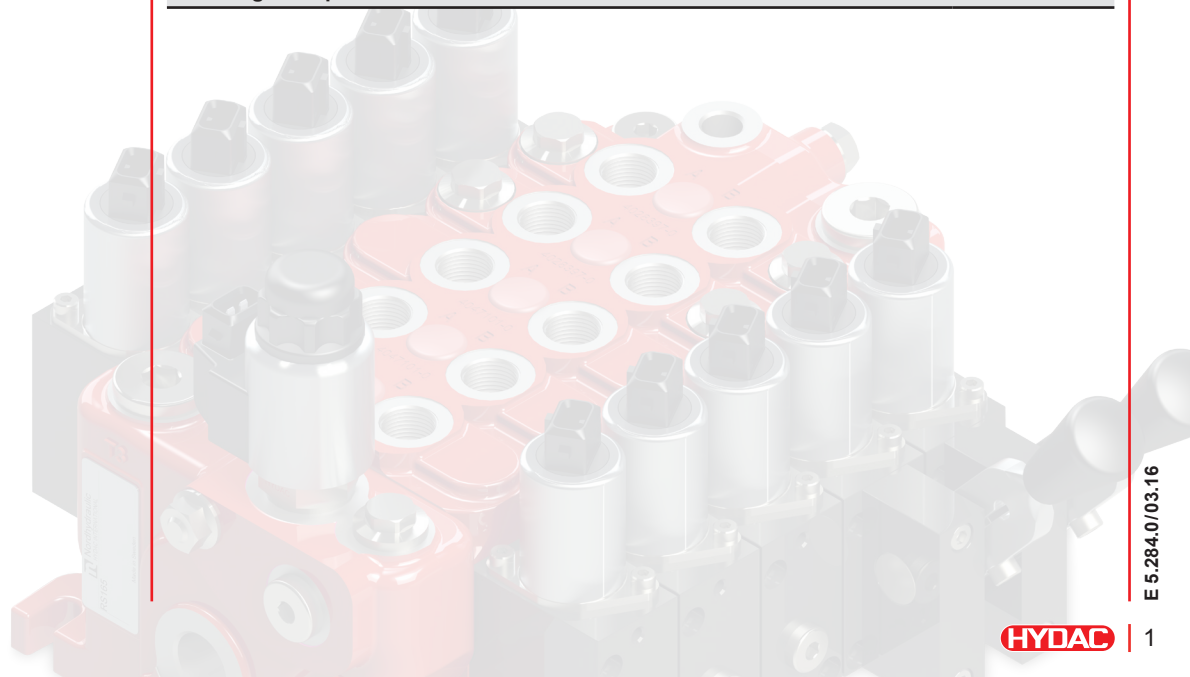

Product features

- Flow-optimized valve design
- Compact size and low weight
- Several connection options for pump and tank
- Applicable for constant and load-sensing pumps
- Symmetrical sections (Inlet plate can be placed left or right)
- Modular design up to 10 working sections
- Operation type is electrohydraulic proportional (with/without mechanical emergency hand lever)
- Shock / anti-cavitation valves for protection of actuators
- Endplate with port for pilot oil supply (optional internal pilot oil supply)
- Two or more valve blocks can be connected in different arrangements
- Areas of application:
 - Outriggers of mobile machines
 - Wheel loader
 - Construction machines
 - Municipal machines
 - Cranes
 - Truck applications
 - Stationary applications
 - Agriculture machines

General information and functional description

The RS 160-EH is a proportional control valve according to the open-center principle with electro-hydraulic operation.

The maximum flow rate to the working ports A and B is 60 l/min. The spool **2.1** determines the flow rate and the flow direction.

The pressure control valves **2.3.1** and **2.3.2** are providing shifting pressure to the face sides of the main spool **2.1**.

The level of electric current determines the level of pilot pressure and therefore the position of the spool.

Shock / anti-cavitation valves **2.5.1** and **2.5.2** protect the working ports A and B from pressure peaks and/or cavitation.

The check valve **2.2** in the parallel channel P" prevents the load from descending if the spool is moved and the pump does not provide the system with enough pressure (on A and B side).

Overview

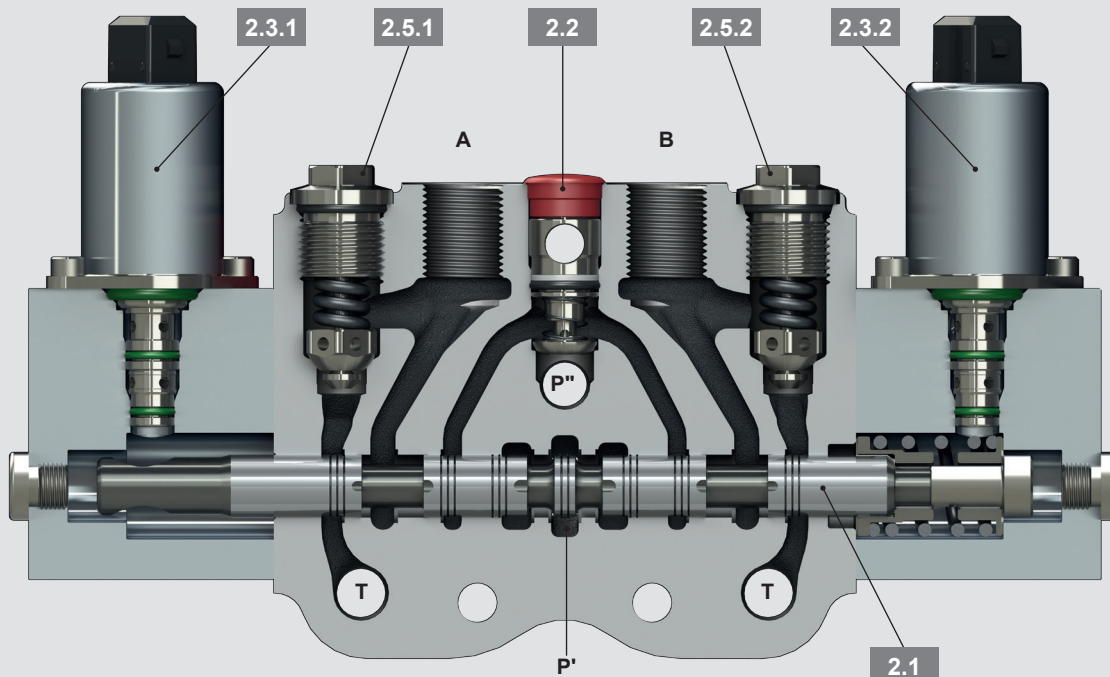

A, B Working ports
T Tank channel
P' Center channel
P'' Parallel channel

2.1	Spool
2.2	Check valve
2.3.1	Pressure control valve A side

2.3.2	Pressure control valve B side
2.5.1	Working port valve port A
2.5.2	Working port valve port B

Overview

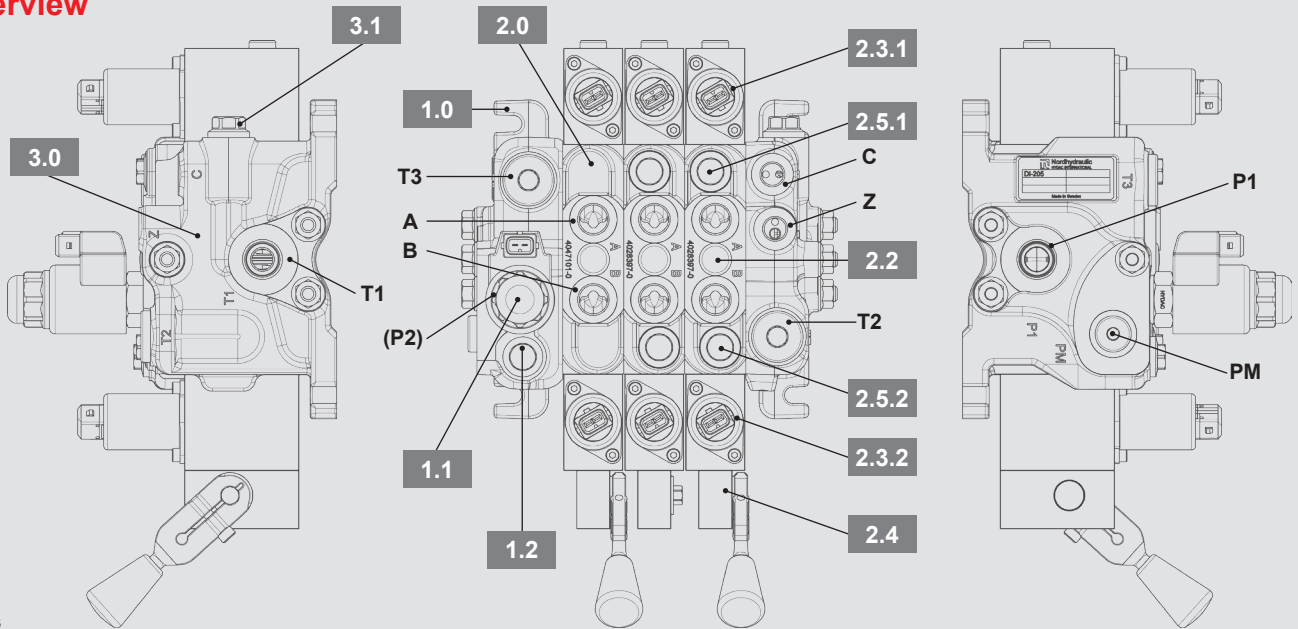

Ports

- P1, P2 Pump
- PM Pump measuring port
- T1, T2, T3 Tank
- A, B Working ports
- Z Pilot drain

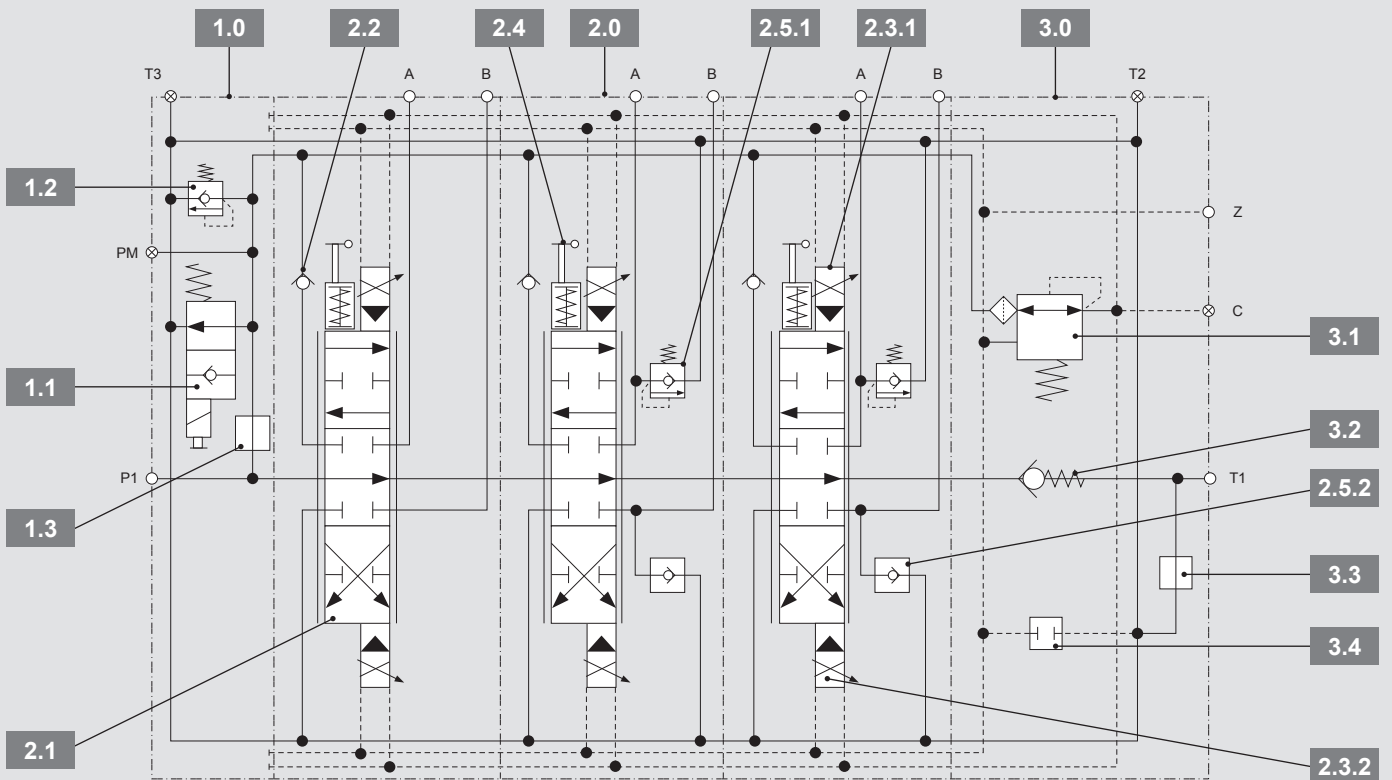

1.0	Inlet plate
1.1	Unloading valve
1.2	Main relief valve
1.3	Parallel channel connection or separation
2.0	Working section
2.1	Spool
2.2	Check valve
2.3.1	Pressure control valve port A
2.3.2	Pressure control valve port B

2.4	Mechanical emergency actuation
2.5.1	Working port valve A side
2.5.2	Working port valve B side
3.0	End plate
3.1	Pressure reducing valve for pilot oil supply
3.2	Center channel precharging valve
3.3	Tank connection or high pressure carry over
3.4	Connection or separation pilot drain to tank

Technical data

General data and operating conditions			
No. of working sections		1 ... 10	
Installation position		optional	
Mass in kg	Inlet plate P15 / U15	2,8 / 3,1	
	Working section	BP4E	2,3
		SP4E	2,2
	Operation unit EH	0,4	
	Mechanical emergency hand lever	0,1	
	End plate E5E1 / E5E2	2,1	
	Tie rod for working section 2 / 4 / 6 / 8	0,2 / 0,3 / 0,4 / 0,5 / 0,6	
Connection type (thread type)		BSPP (acc. to ISO 1179-1); SAE (acc. to ISO 11926-1 or SAE J1626)	
Ambient temperature range		-20 ... +60 °C	
Hydraulic fluid temperature range		-15 ... +80 °C	
Painting		Standard primer or top coat RAL 9005 on inquiry	
Hydraulic data			
Max. flow rate	P1, P2, A, B	60 l/min	
Max. operating pressure at port	A, B, P1, P2, PM, HPCO	250 bar	
	T1, T2, T3	25 bar 10 bar for internal connection Z → T	
	Z	10 bar, drained to tank preferred	
	External pilot oil supply C	30 bar max.	
Pilot pressure range		4,5 to 17,7 bar electrohydraulic	
Required min. pump pressure at block		8 bar	
Hydraulic fluid		Mineral oil (HL / HLP) acc. to DIN 51524, other hydraulic fluids on inquiry	
Viscosity range		10 – 400 mm ² /s	
Max. permitted degree of contamination of the hydraulic fluid		20/18/15 acc. to ISO 4406 (c)	
		Please contact HYDAC Filtration Technology to ensure system cleanliness	
Electrical data			
Supply voltages		12 V DC / 24 V DC	
Solenoid data		See section "Operation units" and "Solenoid valves and coils"	
Connector type and IP protection class (with mating connector mounted and locked)		AMP Junior Timer, 2-pin, axial / up to IP6K6 ¹⁾	
		Deutsch DT04, 2-pin, axial / up to IP6K9K ¹⁾	
Amplifiers and control devices		See product catalogue 18.500 – Control technology for mobile machines	

¹⁾ Mating plug-in connectors are not included

⚠ The technical data were measured at a viscosity of 32 mm²/s.

Characteristic curves

Pressure drop P1 → T1

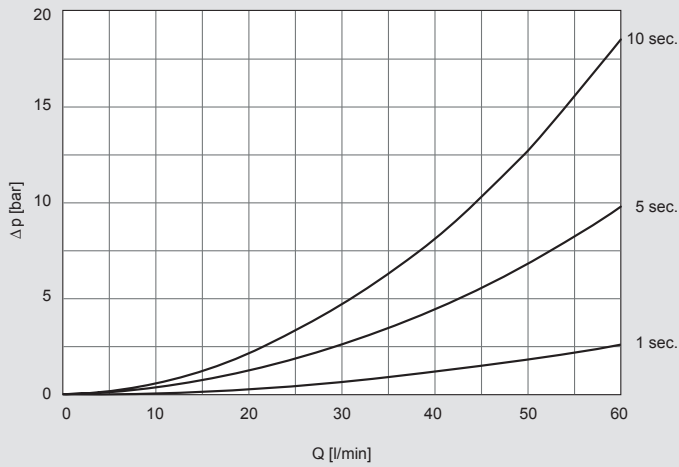

Pressure drop P1 → T1, released by unloading valve

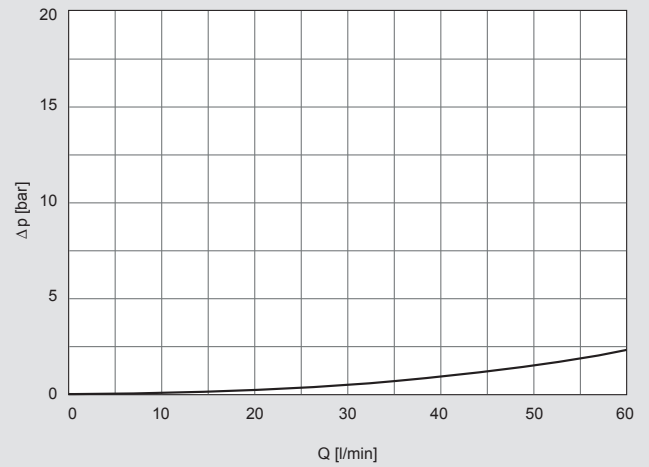

Pressure drop P1 → T1 (T3)

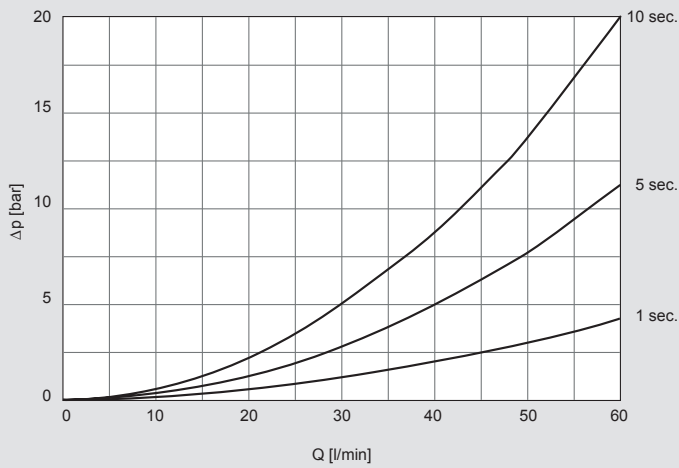

Pressure drop P1 → A/B

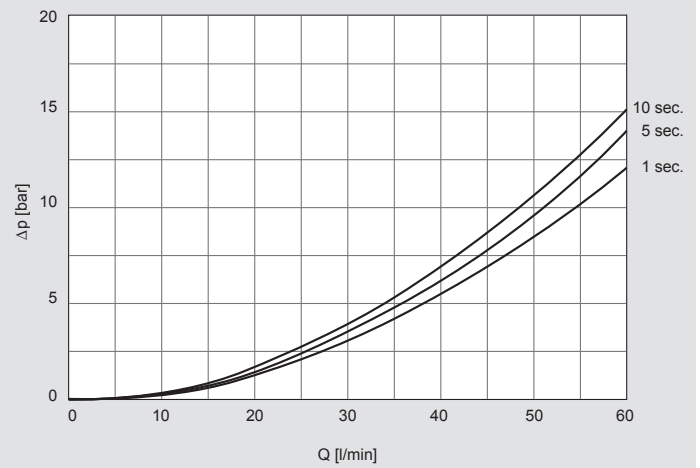

Pressure drop A/B → T1

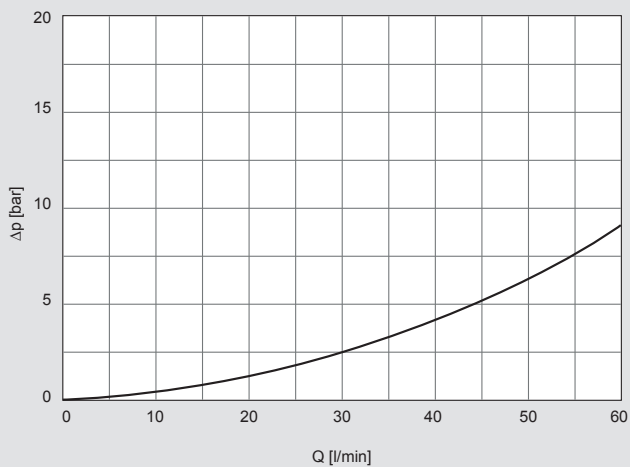

- ⚠ The characteristic curves were measured with a 16AA-spool (max. volume flow 60 l/min) at a viscosity of 32 mm²/s.
- ⚠ The pressure drop from P1 to T1 will have an additional Δp -Offset of 8 bar while using the center channel precharging valve

Modular structure

The RS 160-EH can be customized to different applications and machines.

The principle sectional design and modular structure consists of an inlet plate, max. 10 working sections and an end plate. A complete control block is defined by a type code system.

Setup with left hand inlet plate

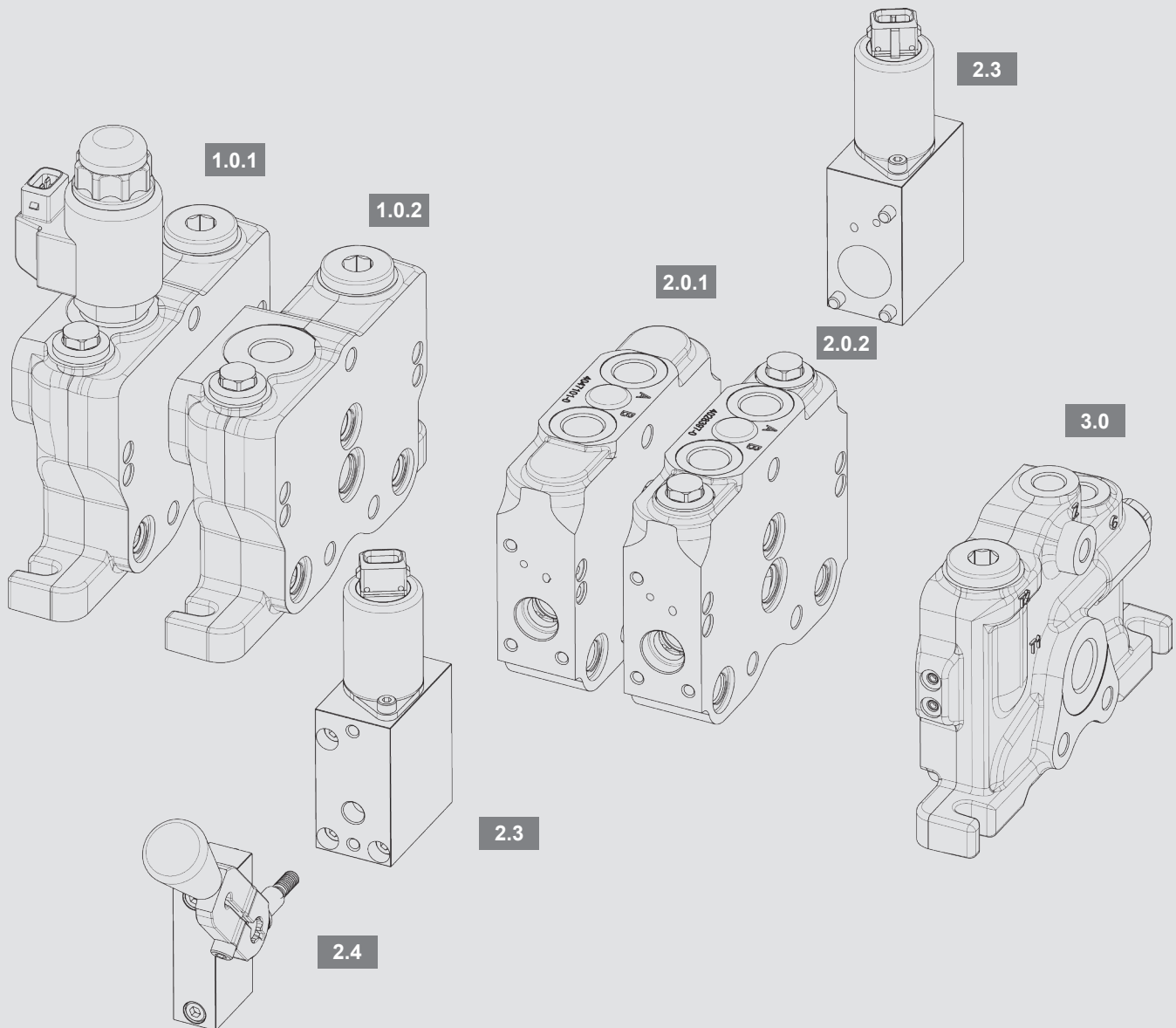

Type code structure

General

RS 16_-EH / B0

Connection type B (BSPP) or S (SAE)

No. of working sections (1 .. 0 (0 = 10 working sections))

Inlet plate

U15 / Y1A / 250F

1.0.1

Inlet plate U15 / Y1A / 250F

1.0.2

Inlet plate P15 / ... / ...

Working section

BP4E / 11AZ / ...

2.0.1

Working section BP4E, SP4E

2.0.2

Working section BP4E, SP4E

2.3

Electrohydraulic operation EH01A, ...

2.4

Mechanical emergency actuation

End plate

E5E2 / ...

3.0

End plate E5E2 / ...

Example of block specification and type code

Example: Control block for hydraulic system with center channel precharging valve

Type code

Control block specification

Valve type

RS 163-EH

RS 160-EH with 3 working sections

RS 163-EH / B0

B0

Connection type BSPP, valve series 0

Inlet plate

U15

Inlet plate with unloading valve

U15 / Y1D / 250F

Y1D

Unloading valve, normally open, with 12 V solenoid and connector type Deutsch DT04-2P

250F

Main relief valve fixed setting of 250 bar

Working section 1

BP4E

Working section w/o shock / anti-cavitation valves – parallel section

BP4E / 12AA / EHA1D

12AA

3 position spool, double acting, neutral position closed, max. flow 20 l/min

EHA1D

Electrohydraulic operation, with hand lever axis, mounted on A side 12 V solenoid and connector type Deutsch DT04-2P

Working sections 2 and 3

SP4E

Working section with shock / anti-cavitation valves – parallel section

SP4E / 14AA / 180F – A / EHA1D

14AA

3 position spool, double acting, neutral position closed, max. flow 45 l/min

180F – A

Working port valve A side fixed setting of 180 bar, anti-cavitation valve B side

EHA1D

Electrohydraulic operation, with hand lever axis, mounted on A side 12 V solenoid and connector type Deutsch DT04-2P

End plate

E5E2

End plate with internal pilot oil supply

E5E2 / 0C

0C

Z port, center channel precharging valve, no high pressure carry over

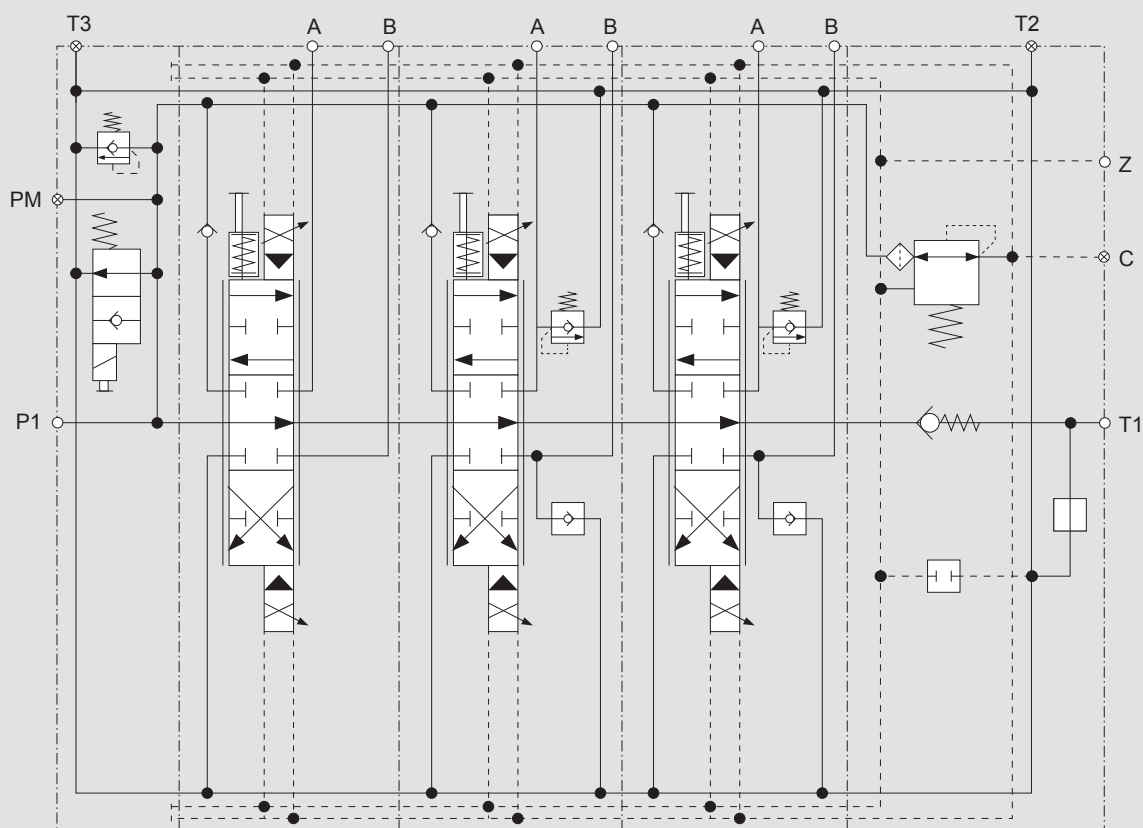

Inlet plate P15

Type code

P15 / 180F / 0

1 2 3

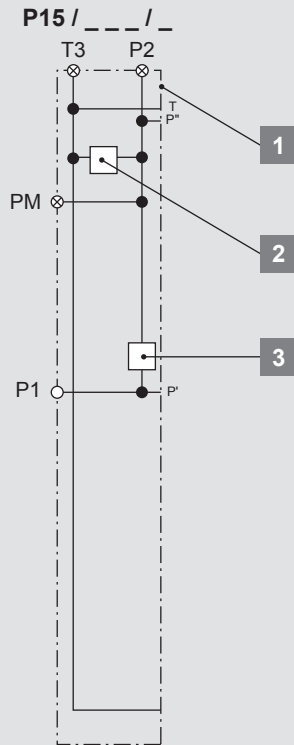

1 Basic type

P__	Inlet plate with P2 port (w/o unloading valve)
_ 1 _	Version
__ 5	Port size P1 ¹⁾

2 Main relief valve²⁾

___ F	Pressure setting in bar, 3-digit, fixed set, max. 250 bar (TBS)	
P	Plug screw (P110)	

3 Cavity for fitting

0	Parallel channel connected to center channel	
1	Parallel channel disconnected from center channel (K16)	
L	Throttled connection (Load-sensing pumps) on request (L16)	

¹⁾ see section – Connection type, fastening and tie rods

²⁾ see section – Working port valves

Fitting in cavity pos. 3:

- Parallel channel connected to center channel w/o fitting (standard)
- Parallel channel disconnected from center channel with fitting K16 “1” (see section – Block connection examples)
- Using a load-sensing pump with fitting L16 “L”, use P1 port as load sensing port, pump is connected to P2 port

Example configurations

P15 / 180F / 0

- Inlet plate with P2 port (w/o unloading valve)
- Main relief valve fixed setting of 180 bar
- Parallel channel connected to center channel

P15 / P / 1

- Inlet plate with P2 port (w/o unloading valve)
- No main relief valve
- Parallel channel disconnected from center channel

P15 / 190F / L

- Inlet plate with P2 port (w/o unloading valve)
- Main relief valve fixed setting of 190 bar
- Throttled connection between parallel and center channel for use of load sensing pumps
- The throttle adjustment has to be done individual, on request only

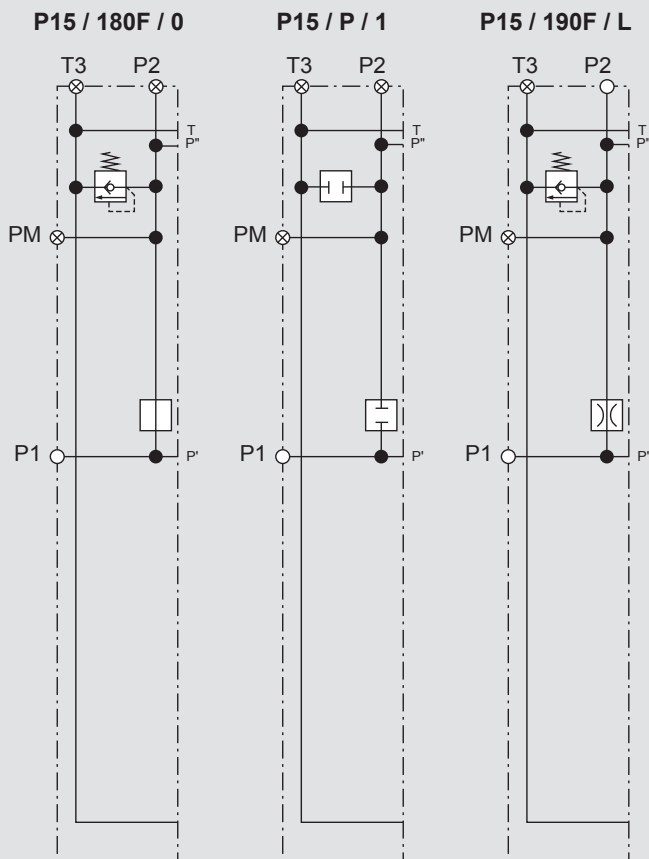

Inlet plate U15

Type code

U15 / Y2D / 180F

1 2 3

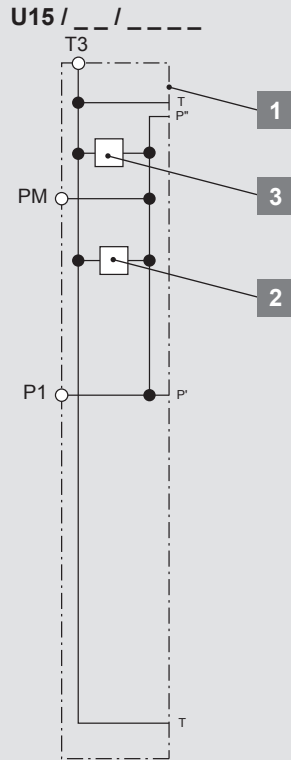

U15 / Y2D / 180F

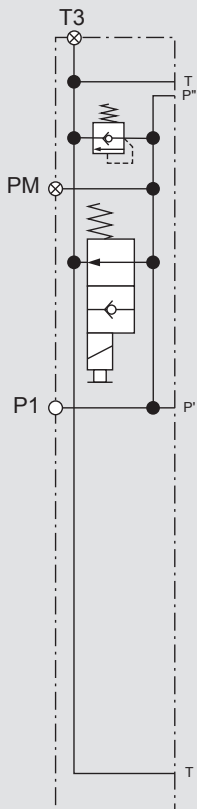

U15 / Y1A / P

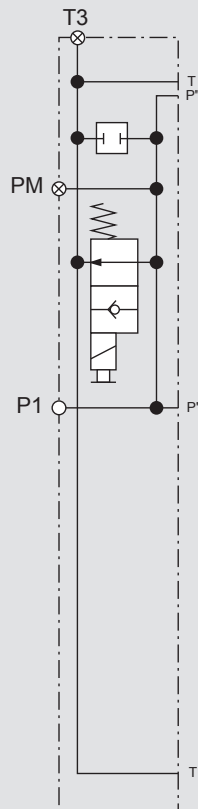

1 Basic type

U _ _	Inlet plate with unloading valve, normally open, with manual emergency override
_ 1 _	Version
_ _ 5	Port size P1 ¹⁾

2 Solenoid (Electrical supply voltage, connector type)²⁾

Y _ _	Unloading valve normally open
_ 1 _	12 V
_ 2 _	24 V
_ _ A	AMP Junior Timer, 2-pin – axial
_ _ D	Deutsch DT04-2P, 2-pin – axial

P	Plug screw	
---	------------	--

3 Main relief valve³⁾

_ _ _ F	Pressure setting in bar, 3-digit, fixed set, max. 250 bar (TBS)	
---------	---	--

P	Plug screw (P110)	
---	-------------------	--

¹⁾ see section – Connection type, fastening and tie rods

²⁾ see section – Solenoid valves and coils

³⁾ see section – Working port valves

⚠ The inlet plate U15 may not be used for load sensing pumps.

Example configurations

U15 / Y2D / 180F

- Inlet plate with unloading valve
- Solenoid 24 V and connector type Deutsch DT04-2P
- Main relief valve fixed setting of 180 bar

U15 / Y1A / P

- Inlet plate with unloading valve
- Solenoid 12 V and connector type AMP Junior Timer
- No main relief valve

Working sections BP4E / SP4E

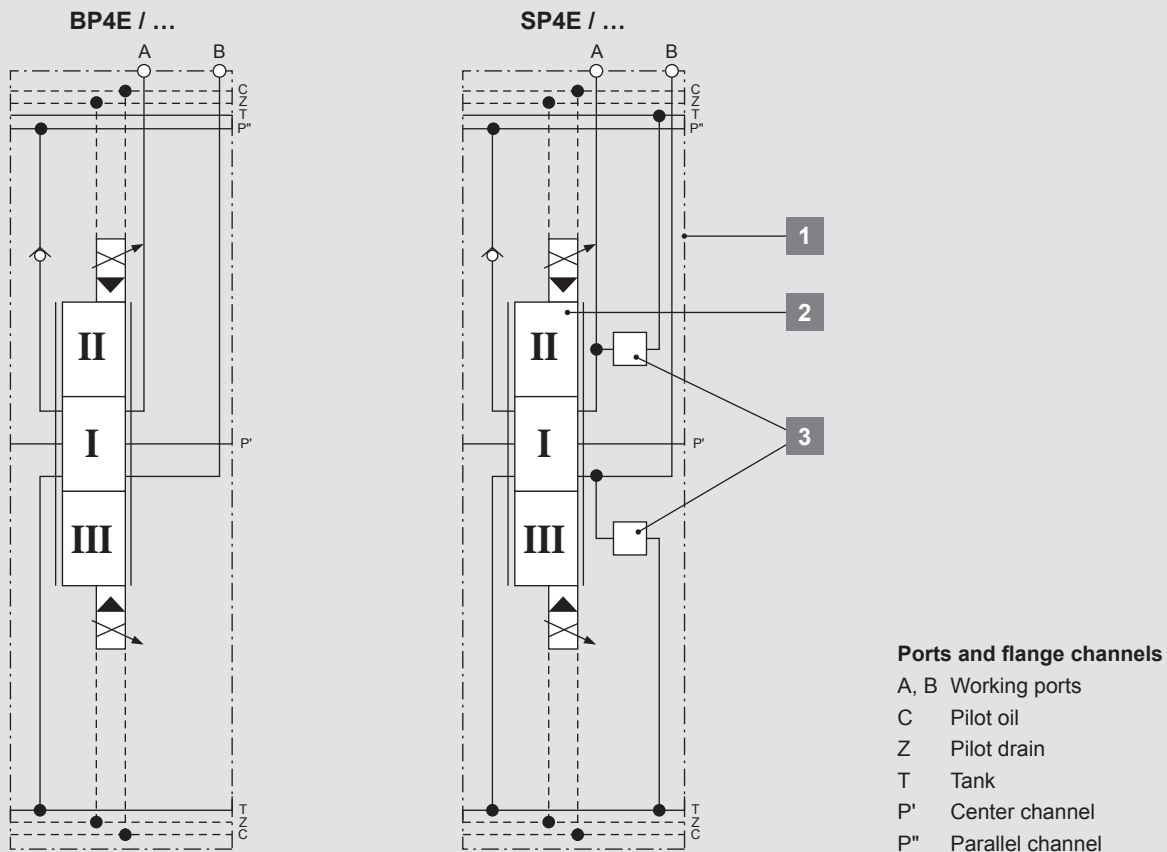

Type code

BP4E / 14AA / ...

SP4E / 12AY / 180F – P / ...

1 2 3

1	Basic types
B _ _ _	Basic section w/o working port valves
S _ _ _	Section with working port valves
_ P _ _	Parallel section
_ _ 4 _	Port size A/B ¹⁾
_ _ _ E	Electrohydraulic operation
2	Spool types
3	Working port valves

¹⁾ see section – Connection type, fastening and tie rods

Section description

Parallel section

The parallel section is the standard section for RS160-EH valve blocks. The parallel channel is connected continuously with the center channel.

Spools

Type code

SP4E / **12AY** / 180F – P / EHB1A-1

Examples

1

2

A

Y

1

2

3

4

1

Type

2

Max. volume flow

3

Principle

4

Details

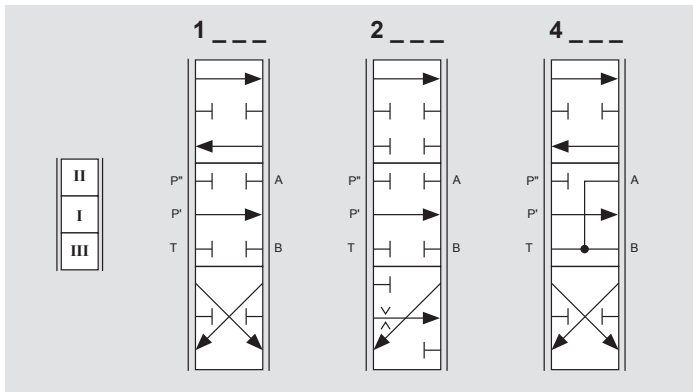

1 Type

1 ___ 4/3-way (double acting)

2 ___ 3/3-way (single acting)

4 ___ Motor spool

Position definition of the spool

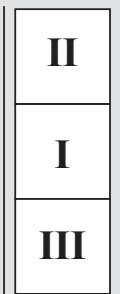

I: Neutral position
II: Volume flow to A
III: Volume flow to B

2 Max. volume flow

_ 1 _ 10 l/min

_ 2 _ 20 l/min

_ 4 _ 45 l/min

_ 6 _ 60 l/min

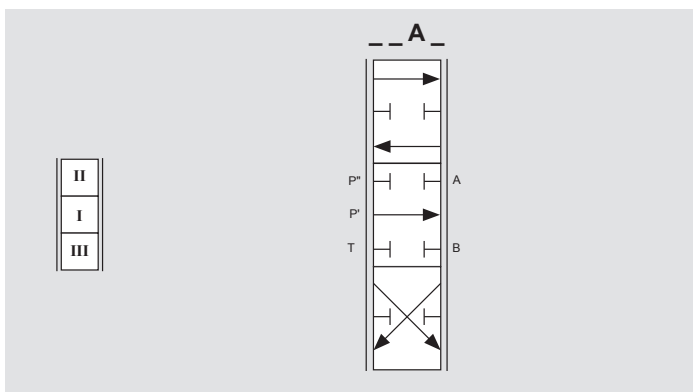

3 Details

_ _ A _ Standard

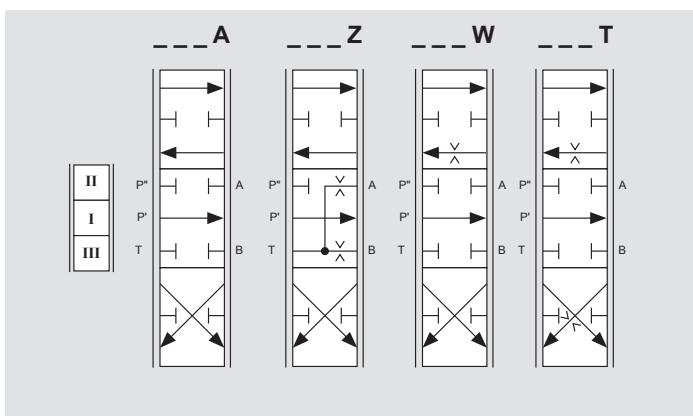

4 Release specification

_ _ _ A Port A and B closed in neutral position; no further release

_ _ _ Z Port A and B throttled to tank in neutral position

_ _ _ X Port A throttled to tank in neutral position

_ _ _ Y Port B throttled to tank in neutral position

_ _ _ T Port A and B throttled to tank

_ _ _ U Port A throttled to tank

_ _ _ W Port B throttled to tank

△ Other spool types and configurations on request

Characteristic curves for nominal flow rates of spool, without load (measured at 32 mm²/s)

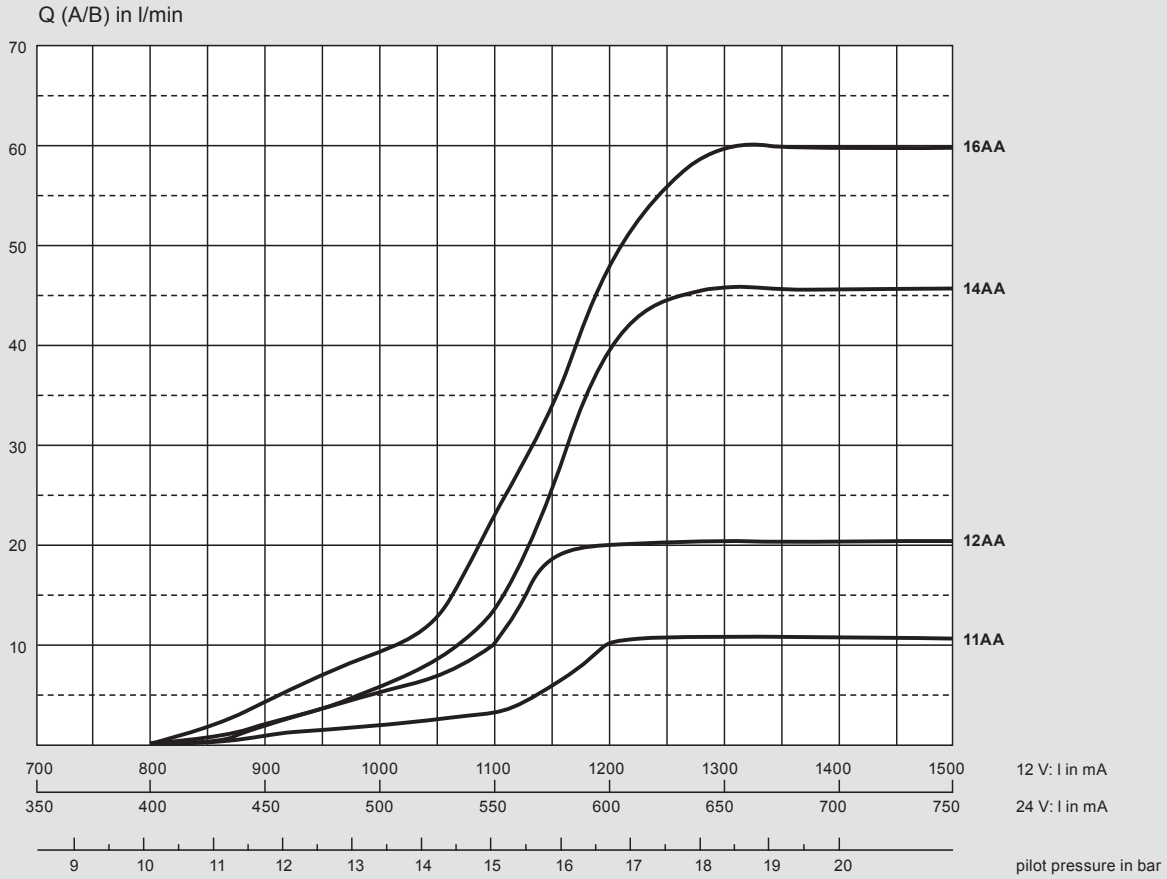

Characteristic curves for nominal flow rates of spool, with 200 bar load (measured at 32 mm²/s)

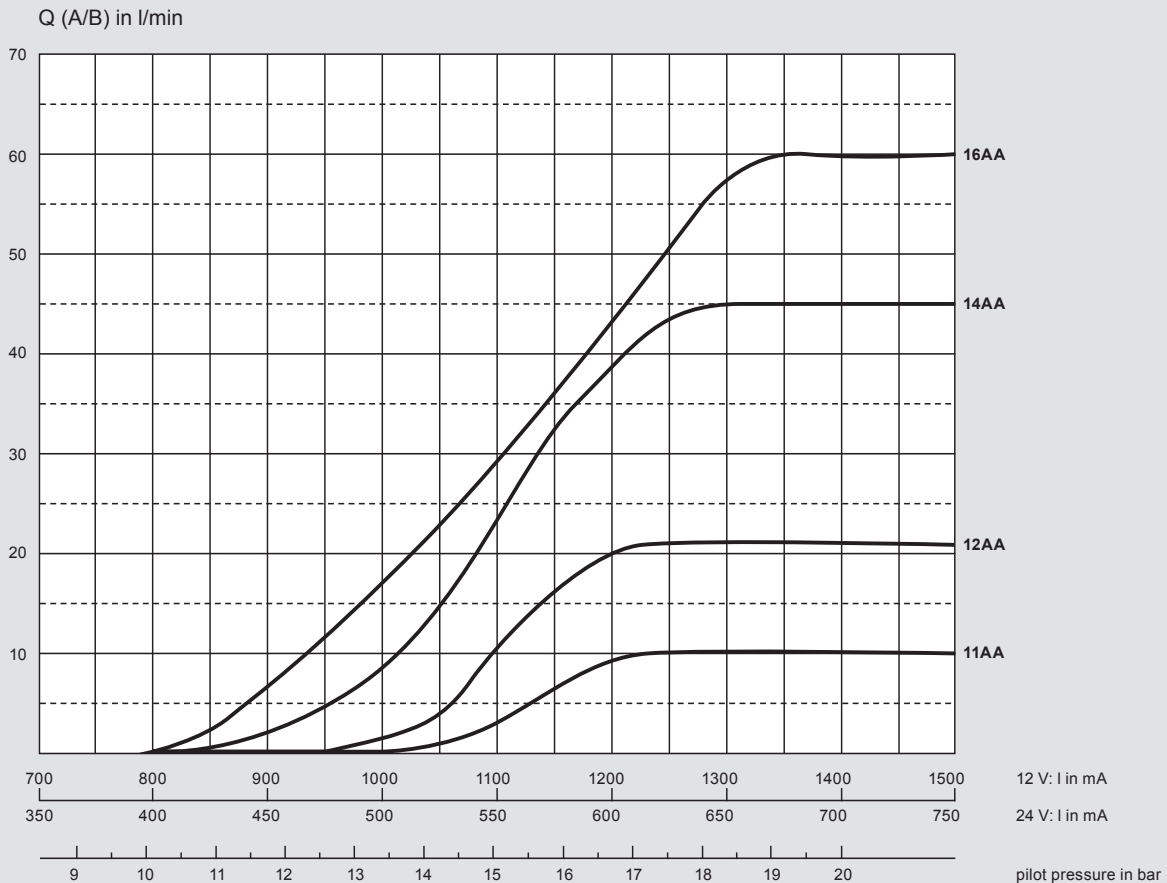

Working port valves

Type code

SP4E / 12AY / 180F - P / EHB1A-1

180F - P

1

2

Shock / anti-cavitation valves protect the working ports A and B against pressure peaks and cavitation.

△ Shock / anti-cavitation valves are fixed set ex works. The pressure setting is defined at a flow rate of 10 l/min.

Pressure settings of fixed Shock / anti-cavitation valves

Pressure range: 50 to 250 bar at 10 bar steps

Pressure range	50 – 100	110 – 160	170 – 250
Tolerance in bar	±5	±7	±10

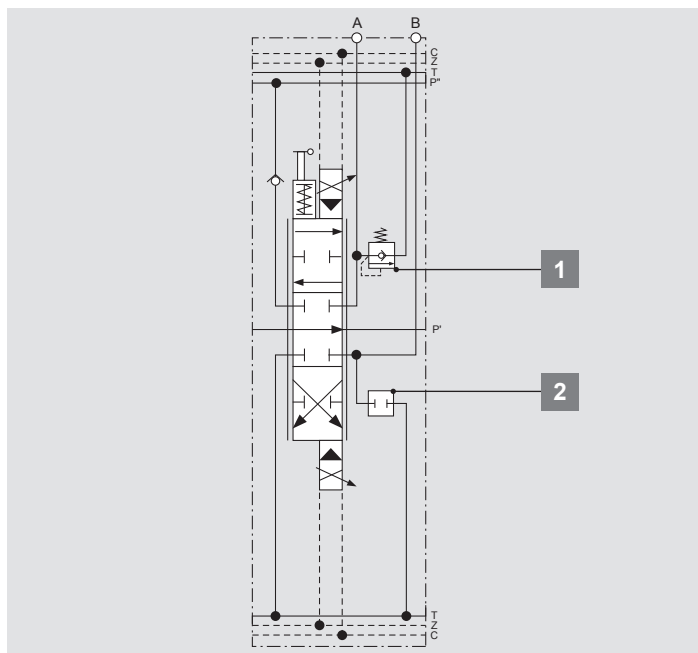

△ With pressure settings above 220 bar, the pressure rise at higher flows during the relieving function has to be considered. The max. pressure of 250 bar may not be exceeded. Elevated tank pressure due to high tank return flow must be taken in account as it will raise the valve setting.

1 Working port valve A side

2 Working port valve B side

Basic types

--- F Pressure setting in bar, 3-digit, fixed set, max. 250 bar (TBS)



A Anti-cavitation valve (SB110)



P Plug screw (P110)



Characteristic curves (measured at 32 mm²/s)

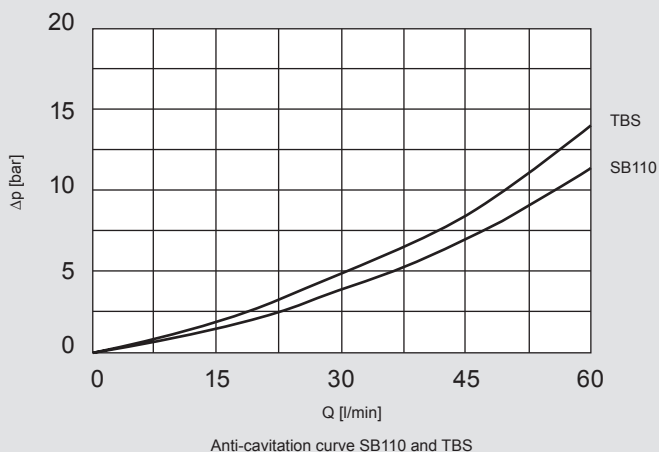

Characteristic curves (measured at 32 mm²/s)

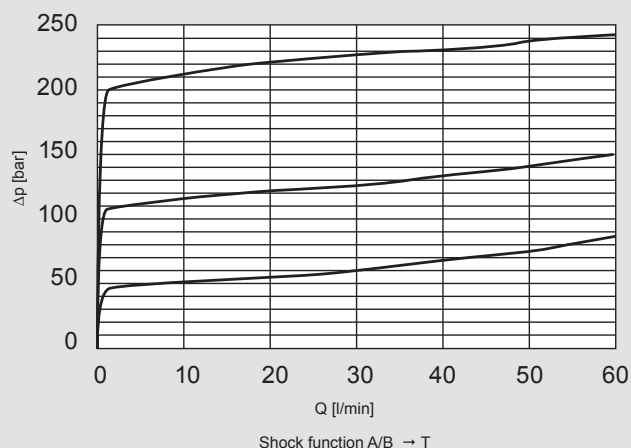

Type code

SP4E / 12AY / 180F – P / **EHB1A-1**



1	Basic type
2	Electrical supply voltage, connector type
3	Mechanical emergency hand lever

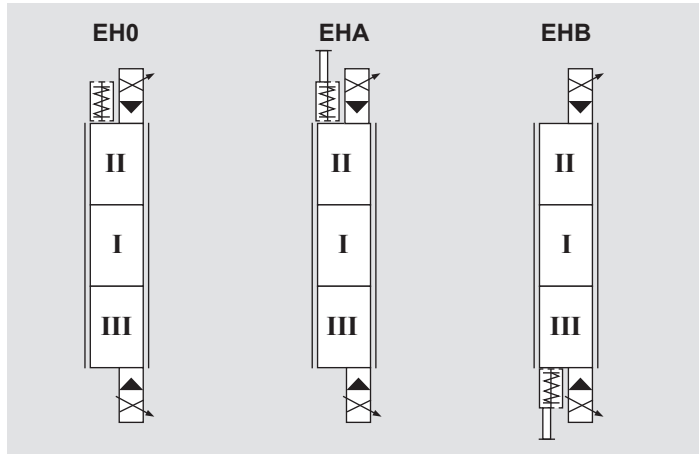

Technical data for electrohydraulic pilot valves

Supply voltage	V DC	12	24
Max. control current	mA	1.500	750
PWM frequency (recommended) ¹⁾	Hz	100 ... 150	
Coil resistance at 20 °C (± 5 %)	Ω	4,7	20,8
Duty cycle	%	100	
Connector type and IP protection class (with mating connector mounted and locked)			
AMP Junior Timer, 2-pin, axial		up to IP6K6 ²⁾	
Deutsch DT04, 2-pin, axial		up to IP6K9K ²⁾	
Protective screen	µm	125	

1 Basic type

EHO	Housing with electrohydraulic operation proportional, w/o emergency hand lever axis
EHA	Housing with electrohydraulic operation, proportional, with emergency hand lever axis on A side
EHB	Housing with electrohydraulic operation proportional, with emergency hand lever axis on B side

¹⁾ The PWM frequency is to be optimized depending on the application

²⁾ Mating plug-in connectors are not included

⚠ Standards ISO 13732-1 and ISO 4413 must be observed in regard to the surface temperatures occurring on the coils.

2 Electrical supply voltage, connector type

1 _	12 V
2 _	24 V
_ A	AMP Junior Timer
_ D	Deutsch DT04-2P

3 Mechanical emergency hand lever

-1 Mechanical emergency hand lever

Interface of hand lever axis and hand lever: Hexagon 9 mm

⚠ To reduce the spool hysteresis, the hand lever is not connected directly to the spool and does not follow the spool movement.

Therefore a return stroke (ca. 17°) has to be made until the spool can be moved, using the mechanical emergency hand lever function.

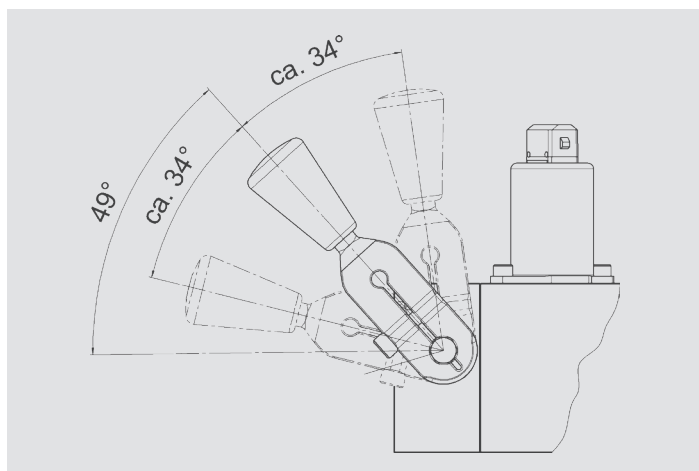

End plates

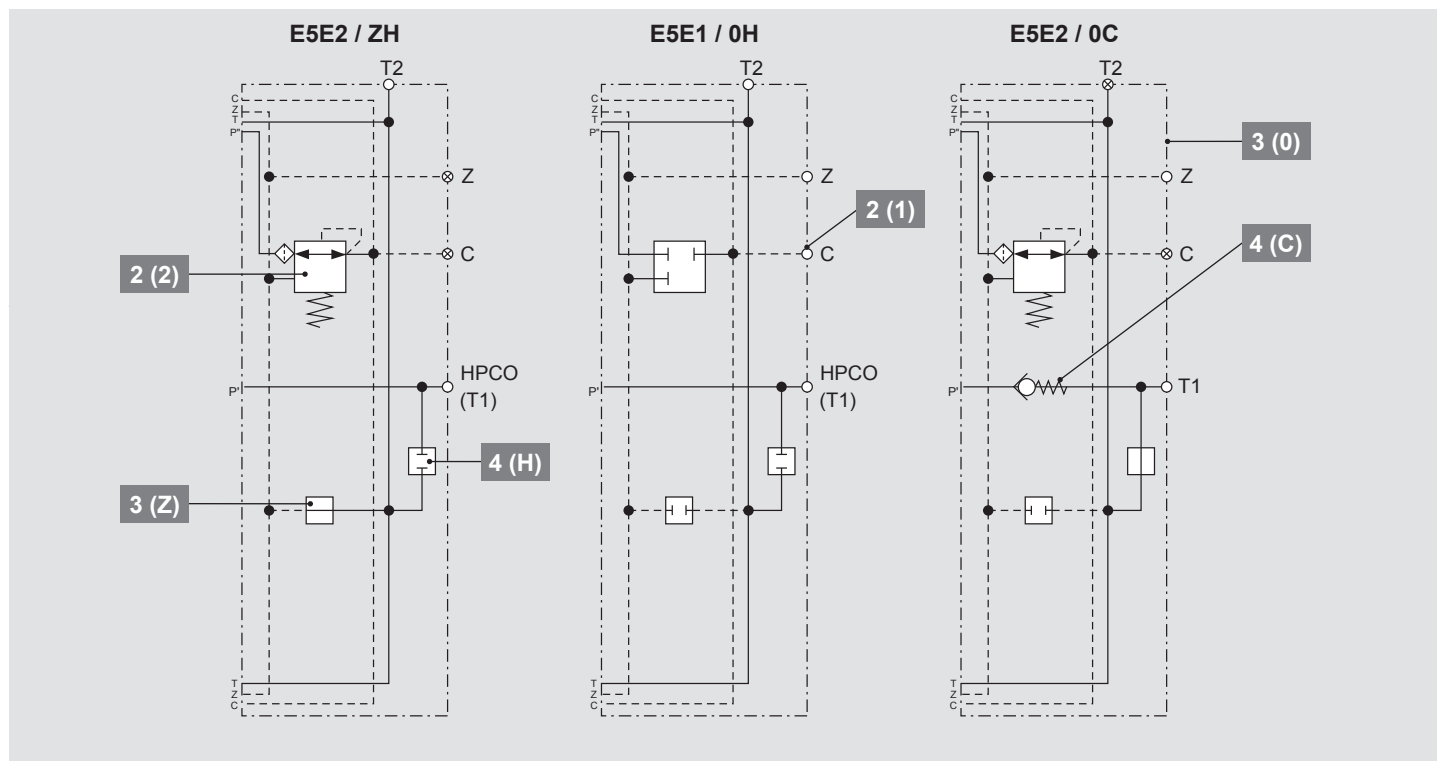

Type code

E5E **2** / **Z** **C**
1 **2** **3** **4**

The center channel precharging valve **4 (C)** provides the center channel with a pressure higher than 8 bar. This ensures that the pilot oil circuit is always supplied sufficiently.

The adapter for the high pressure carry over function (HPCO) **4 (H)** is assembled to port T1 of the end plate. Port T1 can no longer be used as a tank port.

Example configurations

E5E2 / ZH

- End plate with internal pilot oil supply
- Pilot drain internally connected to T
- With adapter for high pressure carry over (HPCO)

E5E1 / 0H

- End plate with external pilot oil supply
- External port for pilot drain
- With adapter for high pressure carry over (HPCO)

E5E2 / 0C

- End plate with internal pilot oil supply
- External port for pilot drain
- With center channel precharging valve

1	Basic type
E _ _ _	End plate
_ 5 _ _	Port size T1 ¹⁾
_ _ E _	electrohydraulic
2	Pilot pressure supply
_ _ _ 1	external pilot pressure oil supply
_ _ _ 2	internal pilot pressure oil supply
3	Pilot drain
0 _	Pilot drain external
Z _	Pilot drain internally connected to T
4	Center channel precharging valve / HPCO
_ C	with center channel precharging valve
_ H	with high pressure carry over (S16)
_ 0	w/o option

¹⁾ see section – Connection type, fastening and tie rods

Solenoid valves and coils

Electrohydraulic pilot valves: see section – Operation units

Unloading valve for inlet plate U15:

On/Off valve:

With manual emergency operation (push-button)

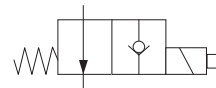

Valve type		Poppet valve	
Nominal voltage U_N	V DC	12	24
Nominal current I_N	A	1,5	0,8
Min. current I_{min}	A	1,05	0,56
Nominal power P_N	W	18	19
Response time	On: ms	35	
	Off: ms	50	
Max. permitted voltage deviation from U_N	%	± 15	
Duty cycle at + 115 % U_N	%	100	
Ambient temperature range ¹⁾	°C	-20 ... +60	
Max. permitted coil temperature ²⁾	°C	180	
Insulation class as per EN 60085		H	
Integrated free-wheeling diode		yes	
Coil length	mm	40	
Connector type and IP protection class (with mating connector mounted)		AMP Junior Timer, 2-pin, axial / up to IP6K6 ³⁾ Deutsch DT04, 2-pin, axial / up to IP6K9K ³⁾	
Valve body and coil surface protection		Zinc-Nickel (ZnNi)	

¹⁾ Deviation of data at request only

²⁾ Standards ISO 13732-1 and ISO 4413 must be observed in regard to the surface temperatures occurring on the coils

³⁾ Mating plug-in connectors are not included

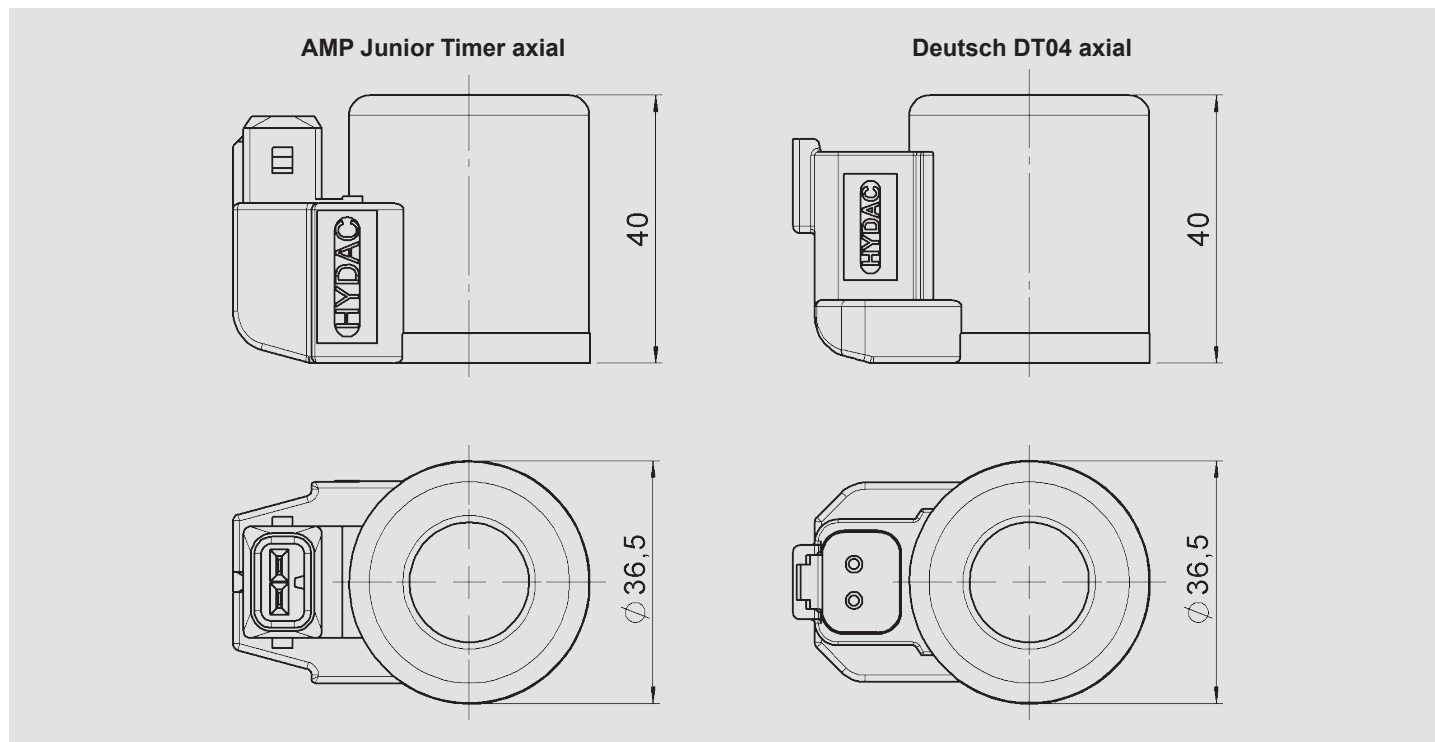

Connection type, fastening and tie rods

Type code

RS16 3 -EH / B 0

1

2

3

4

⚠ Only use fittings with deformable seal materials.

1	Valve type
2	Specification type
-	Complete control block No. of working sections (1 .. 0 (0 = 10 working sections))
X	Single modules (Inlet plate, Working section, end plate)
3	Connection type
B	BSPP acc. to ISO 1179-1
S	SAE acc. to ISO 11926-1 or SAE J1626
4	valve series

Connection type			B	Countersink Ø in mm	S	Countersink Ø in mm	
Inlet plate	P1	Pump	G 1/2	38	7/8-14 UNF	SAE-10	38
	P2	Pump	G 3/8	32	3/4-16 UNF	SAE-8	32
	T3	Tank	G 1/2	30	7/8-14 UNF	SAE-10	30
	PM	Pump measuring port	G 1/4	25	7/16-20 UNF	SAE-4	25
Working section	A/B	Working ports	G 3/8	30	3/4-16 UNF	SAE-8	25
End plate	T1	Tank	G 1/2	37	7/8-14 UNF	SAE-10	37
	T2	Tank	G 1/2	30	7/8-14 UNF	SAE-10	30
	Z	Pilot drain	G 1/4	22	9/16-18 UNF	SAE-6	22
	C	Pilot oil supply	G 1/4	22	9/16-18 UNF	SAE-6	22

Fastening:

Use at least 3 of the 4 fixation points to mount the control block without tensioning.

Fastening screws:

- M8 or 5/16-24 UNF (SAE-2)
- Property class 10.9, fastening torque 25 Nm ± 3 Nm

Tie rods:

M8 tie rods with flange nut 13 mm, $M_z = 20 \text{ Nm} \pm 2 \text{ Nm}$

⚠ Only use genuine RS160-EH tie rod kits.

Installation, usage and maintenance information

Installation, adjustment, maintenance must be done by authorized and trained staff.

The use of this product outside the specified technical limits, use of non-specified fluids and/or use of not genuine spare parts will cause the expiration of the warranty.

Interconnection examples

Parallel connection

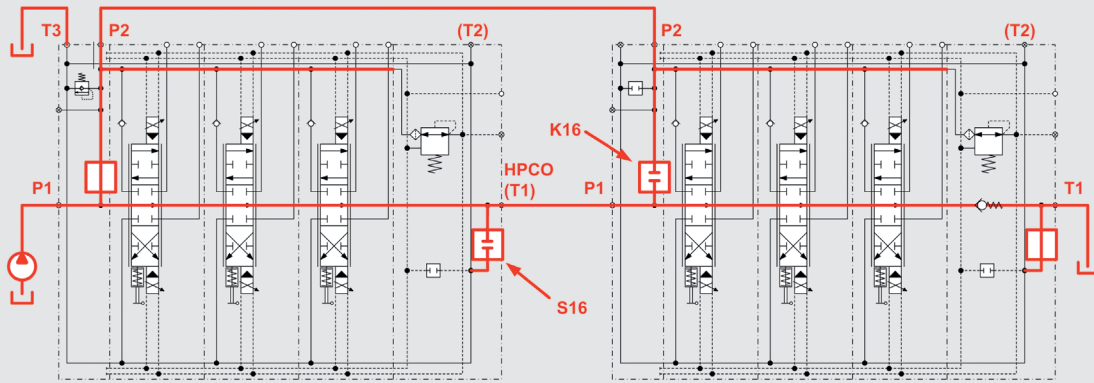

Connecting two blocks parallel, as shown: Connect port T1 of the first block with port P1 of the second block, using adapter S16 and K16. Adapter S16 (HPCO = **H**igh **P**ressure **C**arry **O**ver) disconnects the center channel from the tank channel. Adapter K16 disconnects the parallel channel from the center channel. The P2 ports of both blocks are connected to supply the parallel channel of the second block with pump pressure.

S16 is needed to prevent oil flow from the center channel of the first block to tank (T2 or T3) if a working section of the second block is operated.

K16 is needed to prevent oil flow to tank (T1, T2 or T3) of the second block if a working section of the first block is operated.

Serial connection

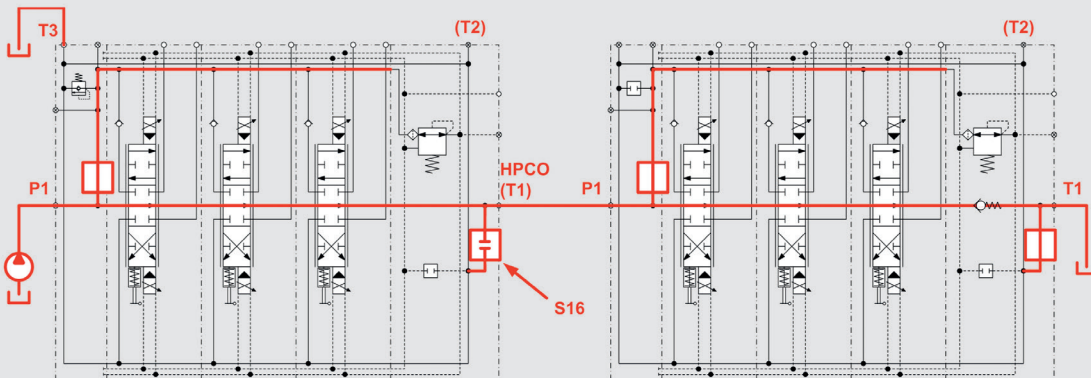

Connecting two blocks serial, as shown: Connect port T1 of the first block with port P1 of the second block, using adapter S16. Adapter S16 (HPCO = **H**igh **P**ressure **C**arry **O**ver) disconnects the center channel from the tank channel. If operating a working section of the first block (full stroke) then operating a working section of the second block is not possible (priority circuit).

S16 is needed to prevent oil flow from the center channel of the first block to tank (T2 or T3) if a working section of the second block is operated.

Loadsensing pump connection

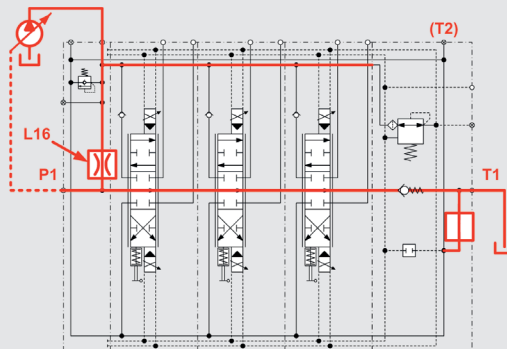

The RS160-EH valve block can also be operated with a Loadsensing pump. Therefore the adapter L16 is needed in port P1, which generates a throttled pressure signal for the pump controller. Port P1 is connected to the pump controller (LS port).

Dimensions

All dimensions in mm, subject to change!

Example of a control block with inlet w/o unloading valve, end plate with external pilot oil supply

Connector types: AMP Junior Timer, 2-pin, axial

1.0	Inlet plate P15 / 250F / 0
1.2	Main relief valve
2.0.1	Working section BP4E
2.0.2	Working section SP4E
2.3	Electrohydraulic operation
2.3.1	Pressure control valve A side
2.3.2	Pressure control valve B side
2.5.1	Working port valve A side
2.5.2	Working port valve B side
3.0	End plate E5E1 / 00
3.2	External pilot oil port C
4.0	Type plate

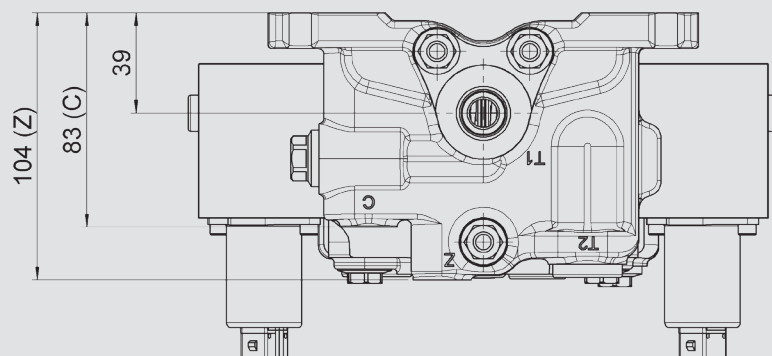
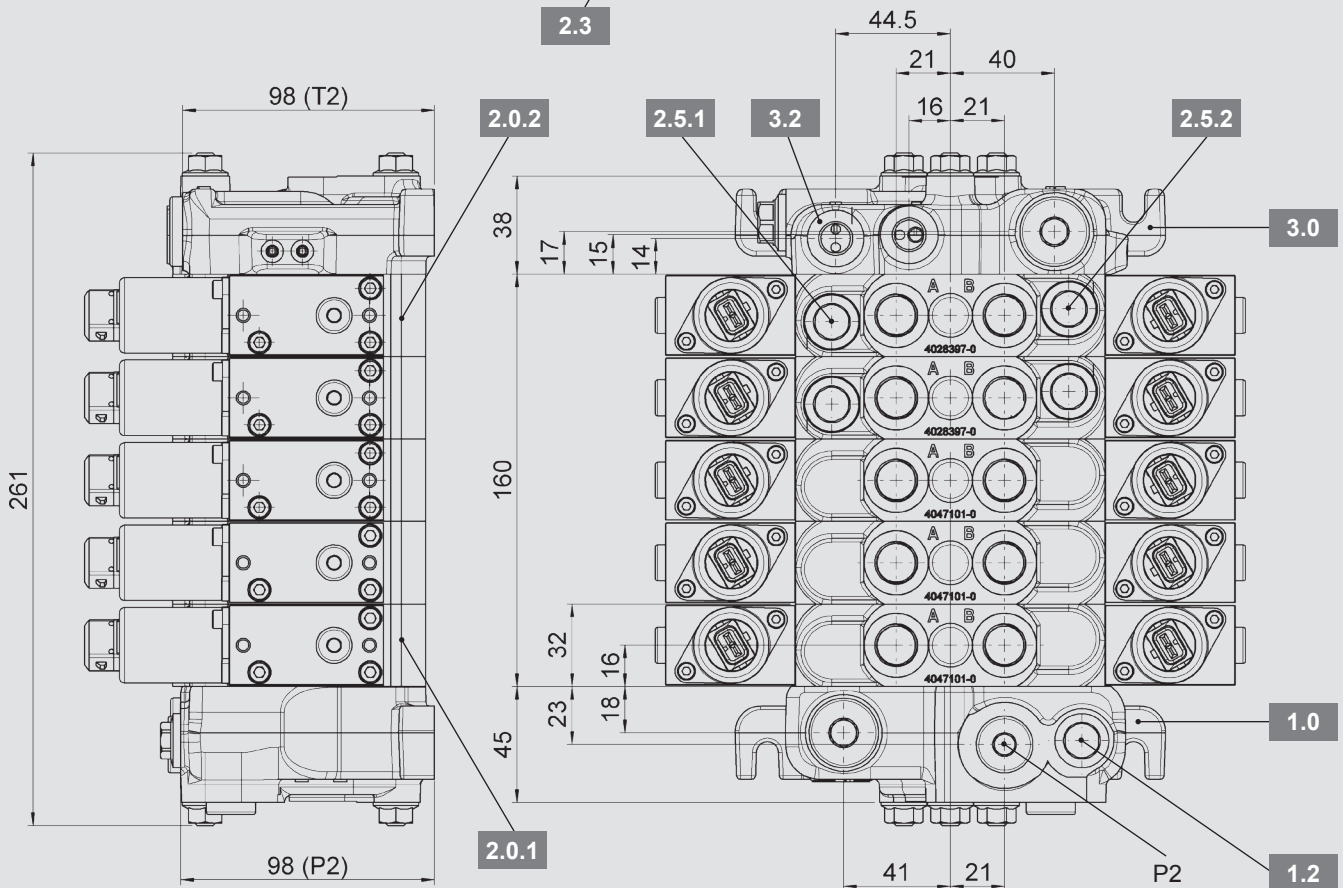
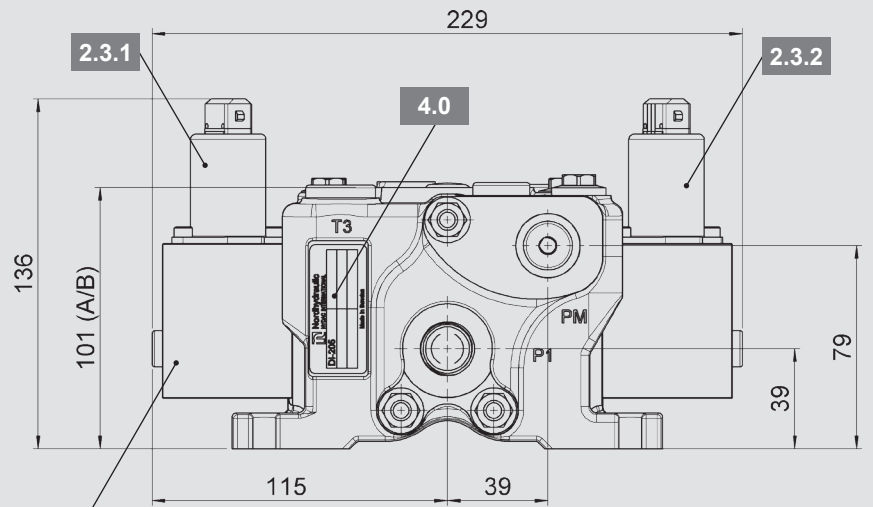

Dimensions

All dimensions in mm, subject to change!

Example of a control block with inlet with unloading valve, end plate with internal pilot oil supply, manual emergency hand lever twice

Connector types: AMP Junior Timer, 2-pin, axial

1.0	Inlet plate U15 / Y2A / 210F
1.1	Unloading valve
1.2	Main relief valve
2.0.1	Working section BP4E
2.0.2	Working section SP4E
2.3	Electrohydraulic operation
2.3.1	Pressure control valve A side
2.3.2	Pressure control valve B side
2.4	Manual emergency hand lever
2.5.1	Working port valve A side
2.5.2	Working port valve B side
3.0	End plate E5E2 / 0H
3.3	Adapter for high pressure carry over
4.0	Type plate

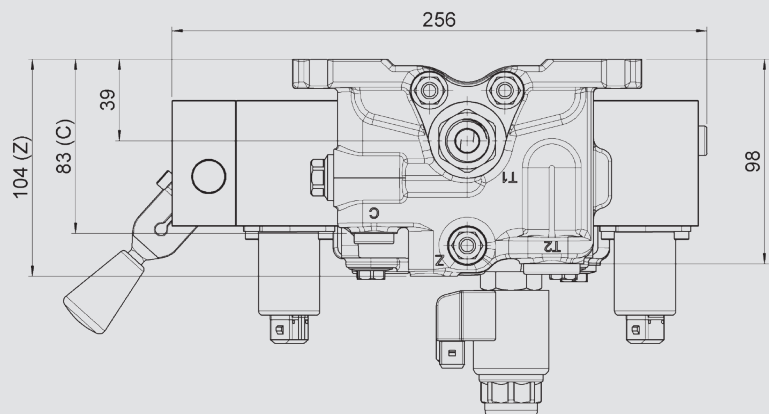
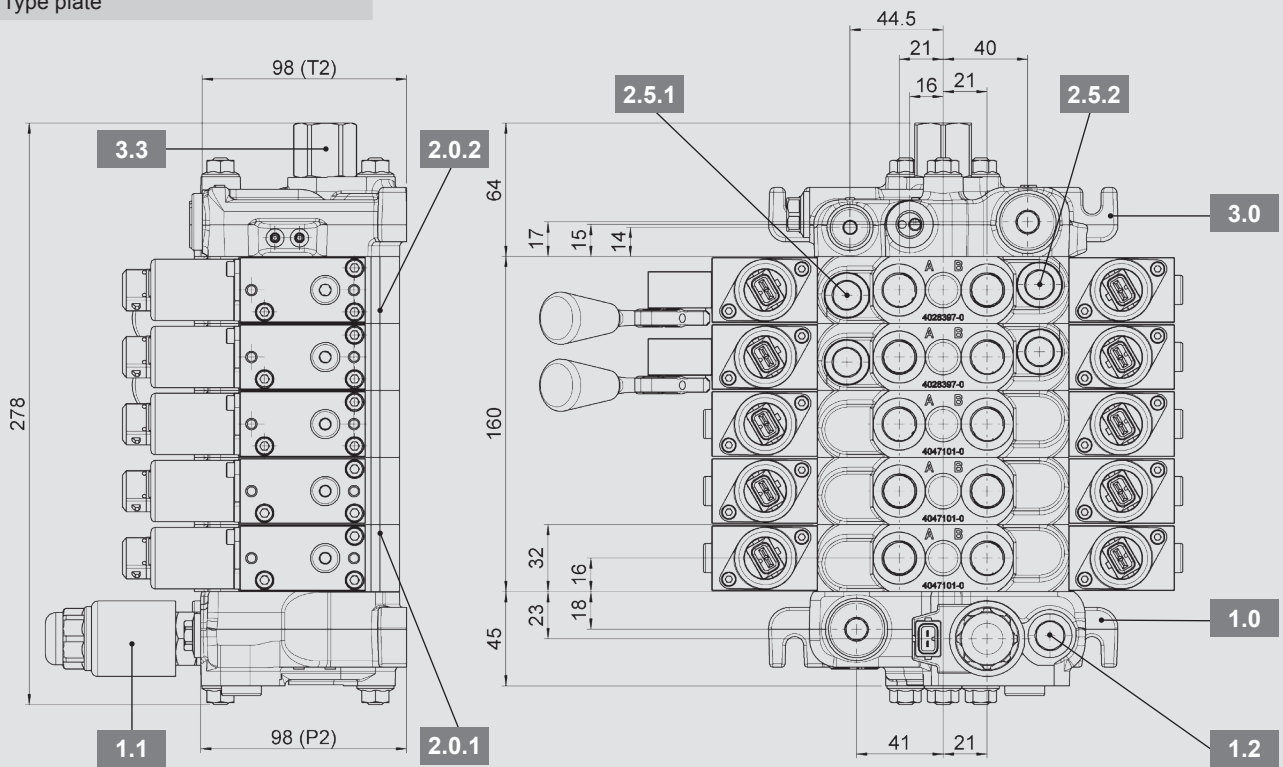
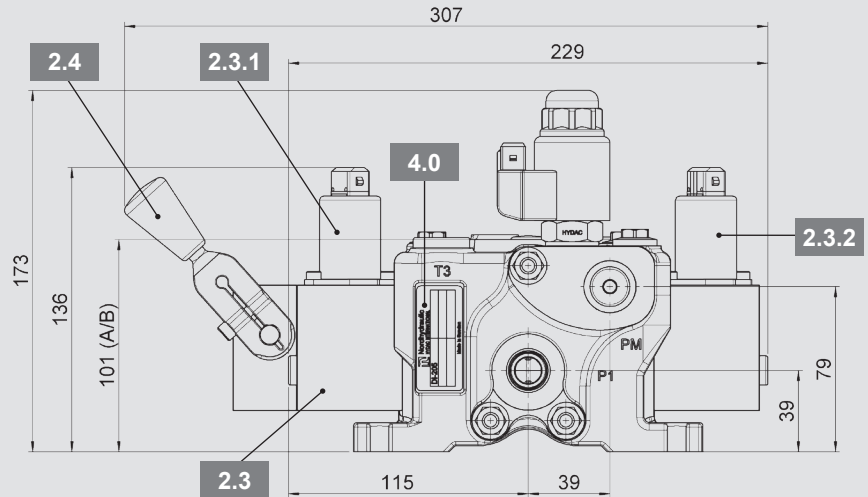

Dimensions

All dimensions in mm, subject to change!

Manual emergency hand lever: Neutral position and max. stroke (see section – Operation units)

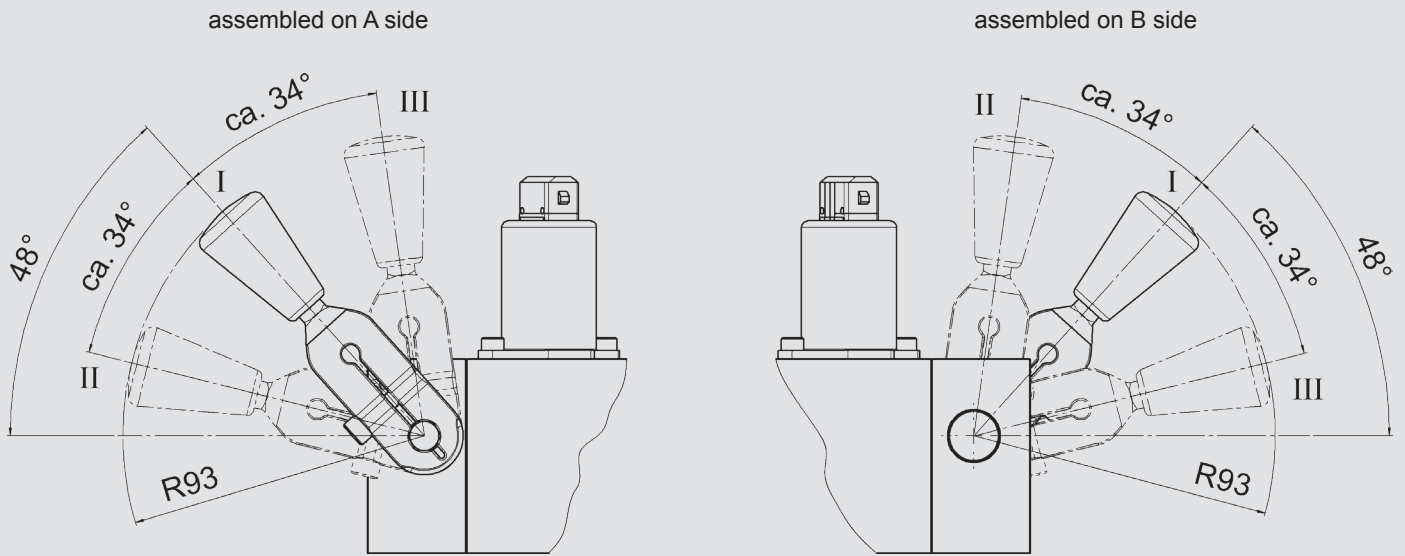

Control block fastening points (4x M8)

The fastening points are equal for all types of inlet and end plates.

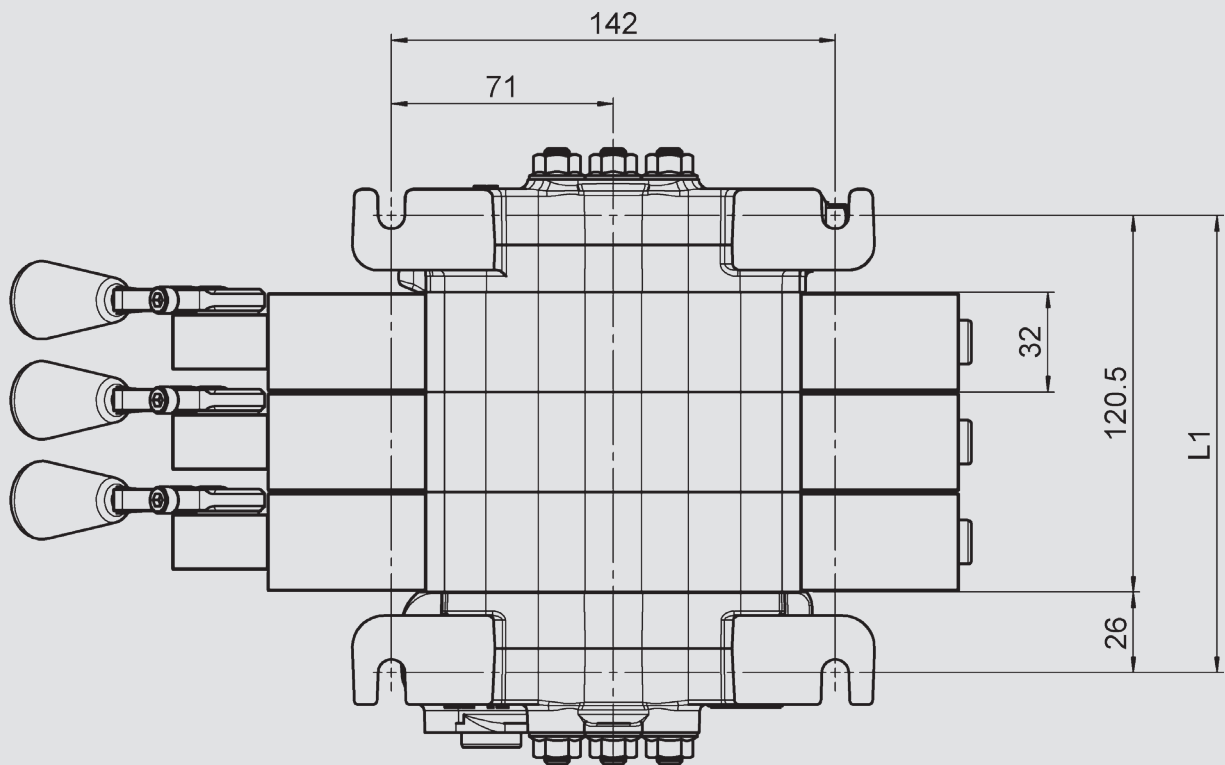

No. of working sections	1	2	3	4	5	6	7	8	9	10	
L1	mm	82.5	114.5	146.5	178.5	210.5	242.5	274.5	306.5	338.5	370.5

Type code

Structure and sequence	1.	General	(control block always defined from left to right)			
	2.	Inlet plate				
	3.	1. Working section 2. Working section n. Working section				
	4.	End plate				

1. General						
Type:	RS16	4	-EH /	B	0	
Pos.	1.	2.		3.	4.	

Pos. / designation:	Type code:	Description / function:	Comment:
1. Open-center valve series	RS16	Open-center valve, Size 2	
2. No. of working sections	—	1-digit, 1 ... 0 (0 = 10 working sections)	max. 10 working sections
Spec. / identification of single module	X	Inlet plate, working section or end plate	
3. Connection thread	B	BSPP acc. to ISO 1179-1	
	S	SAE acc. to ISO 11926-1 or SAE J1626	
4. Valve series	0	Unchanged installation and connection dimensions	

2. Inlet plate						
Type:	P15	/	200F	/	L	
	U15	/	Y1D	/	P	
Pos.	1.		2.		3.	

Pos. / designation:	Type code:	Description / function:	Comment:
1. Basic type			
	P15	P with P2 port 1 version 5 port size P/T	Port size 5: BSPP: G1/2; SAE: 7/8-14 UNF
2. Main relief valve			
	___ F	Pressure setting in bar, 3-digit, fixed set, max. 250 bar (TBS)	see section – Working port valves
	P	Plug screw (P110)	w/o pressure relief valve
3. Cavity for fitting			
	0	Parallel channel connected to center channel	
	1	Parallel channel disconnected from center channel (K16)	
	L	Throttled connection (Loadsensing pumps) on request (L16)	

Pos. / designation:	Type code:	Description / function:	Comment:
1. Basic type			
	U15	U with unloading valve 1 version 5 port size P/T	Port size 5: BSPP: G1/2; SAE: 7/8-14 UNF
2. Unloading valve			
Valve type	Y__	Unloading valve normally open	
Supply voltage DC	__ 1 __	12 V	
	__ 2 __	24 V	
Connector type	__ A	AMP - Junior Timer, 2-pin, axial	
	__ D	Deutsch - DT04, 2-pin, axial	
3. Main relief valve			
	___ F	Pressure setting in bar, 3-digit, fixed set, max. 250 bar (TBS)	see section – Working port valves
	P	Plug screw (P110)	w/o pressure relief valve

Type code

3. Working sections							
Type:	BP4E /	12AA /			EHB2D-1		
	SP4E /	14AZ /	P-180F /		EH01A		
Pos.	1.	2.	3.		4.		
Pos. / designation:	Type code:	Description / function:				Comment:	
1. Basic type							
	B_4_	w/o working port valves 4 port size A/B				Port size 4: BSPP: G3/8; SAE: 3/4-16 UNF	
	S_4_	With working port valves					
	P	Parallel section					
	___E	Electrohydraulic operation					
2. Spool							
1 Type	1 ___	4/3-way, double acting					
	2 ___	3/3-way, single acting					
	4 ___	Motor spool					
2 Max. volume flow	_1 _	10 l/min					
	_2 _	20 l/min					
	_4 _	45 l/min					
	_6 _	60 l/min					
3 Details	__A_	Standard					
4 Release specification	___A	Port A and B closed in neutral position; no further release					
	___Z	Port A and B throttled to tank in neutral position					
	___X	Port A throttled to tank in neutral position					
	___Y	Port B throttled to tank in neutral position					
	___T	Port A and B throttled to tank					
	___U	Port A throttled to tank					
	___W	Port B throttled to tank					
3. Working port valve							
	___F	Pressure setting in bar, 3-digit, fixed set, max. 250 bar (TBS)				see section – Working port valves	
	A	Anti-cavitation valve (SB110)					
	P	Plug screw (P110)				w/o pressure relief valve	
4. Operation units							
1 Basic type	EH0 __	electrohydraulic w/o emergency hand lever axis					
	EHA ___	electrohydraulic with emergency hand lever axis on A side					
	EHB ___	electrohydraulic with emergency hand lever axis on B side					
2 Supply voltage DC, connector type	___1 _	12 V					
	___2 _	24 V					
	___A_	AMP - Junior Timer, 2-pin, axial					
	___D_	Deutsch - DT04, 2-pin, axial					
3 Mechanical emergency hand lever	___-1	Short hand lever for manual emergency operation					

Type code

4. End plate					
Type:	E5E	2	/	Z	H
	E5E	1	/	0	C
Pos.	1.	2.		3.	4.

Pos. / designation:	Type code:	Description / function:	Comment:
1. Basic type			
	E5E _	End plate 5 port size P/T E electrohydraulic	Port size 5: BSPP: G1/2; SAE: 7/8-14 UNF
2. Pilot pressure supply			
	__ _ 1	External pilot pressure oil supply	
	__ _ 2	Internal pilot pressure oil supply	
3. Pilot drain			
	0 _	Pilot drain external	
	Z _	Pilot drain connected internal to T	
4. Center channel precharging valve / HPCO			
	_ C	With center channel precharging valve	
	_ H	With high pressure carry over (HPCO)	
	_ O	w/o option	

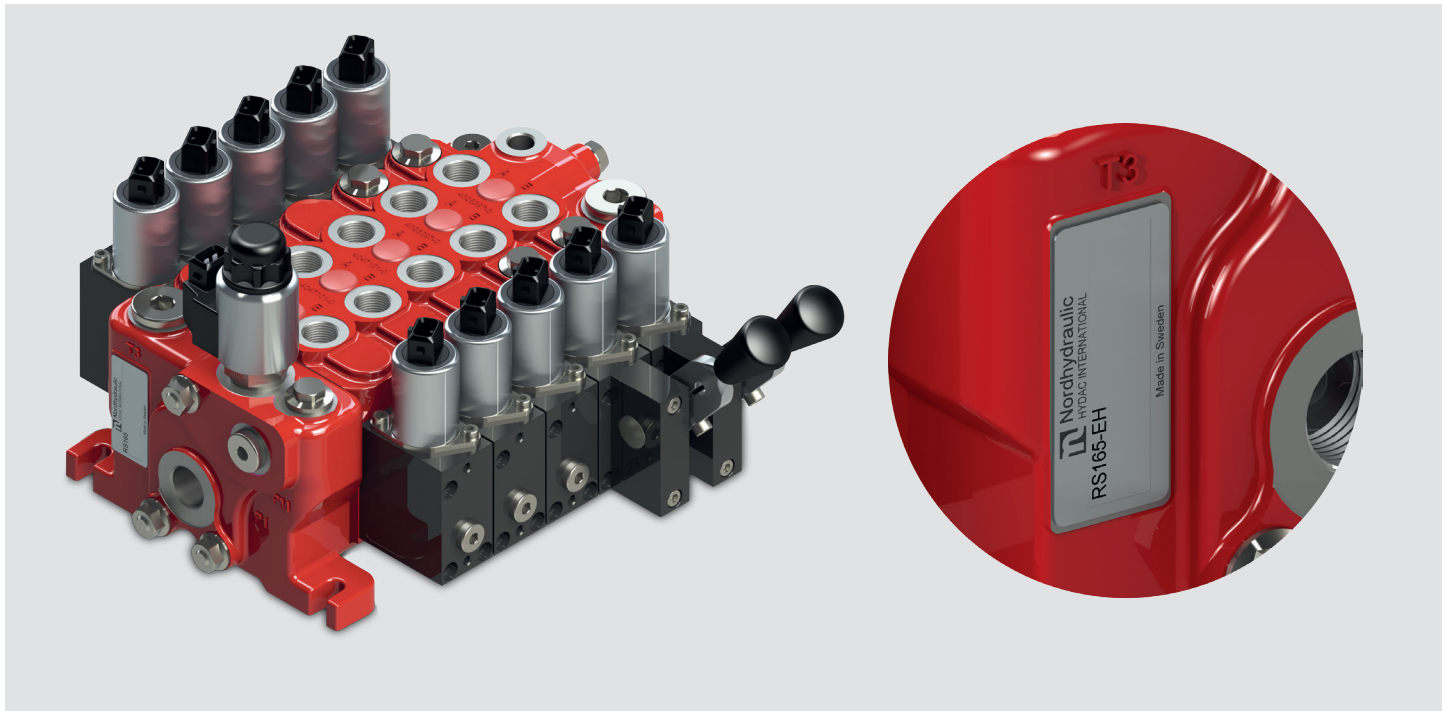

Ordering examples

Example of a control block with unloading valve in the inlet plate and internal pilot oil supply in the end plate

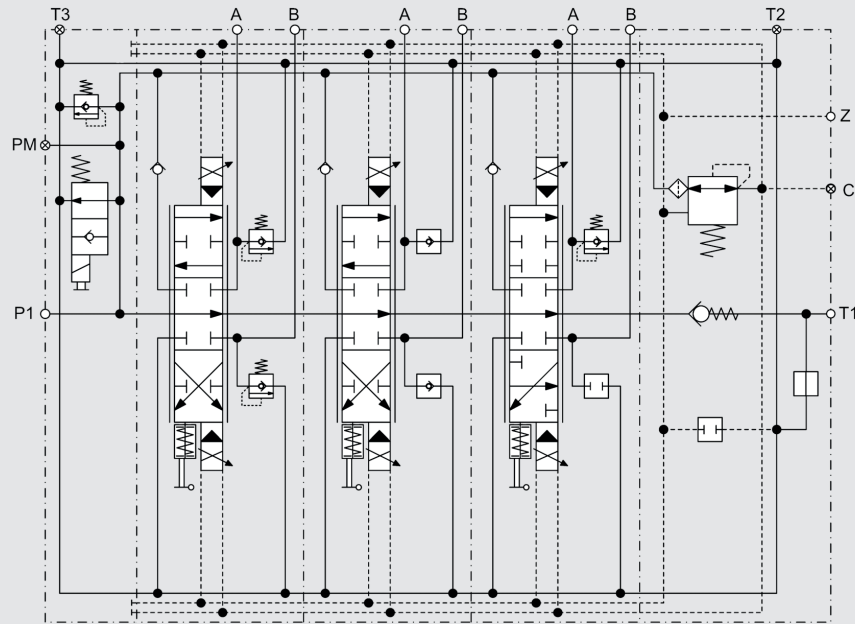

General	RS 163-EH / B0
Inlet plate	U15 / Y2D / 230F
1. Working section	SP4E / 12AA / 250F – 250F / EHB2D-1
2. Working section	SP4E / 14AA / A – A / EHB2D-1
3. Working section	SP4E / 22AA / 250F – P / EHB2D-1
End plate	E5E2 / 0C

Example of a control block with external pilot oil supply and HPCO in the end plate

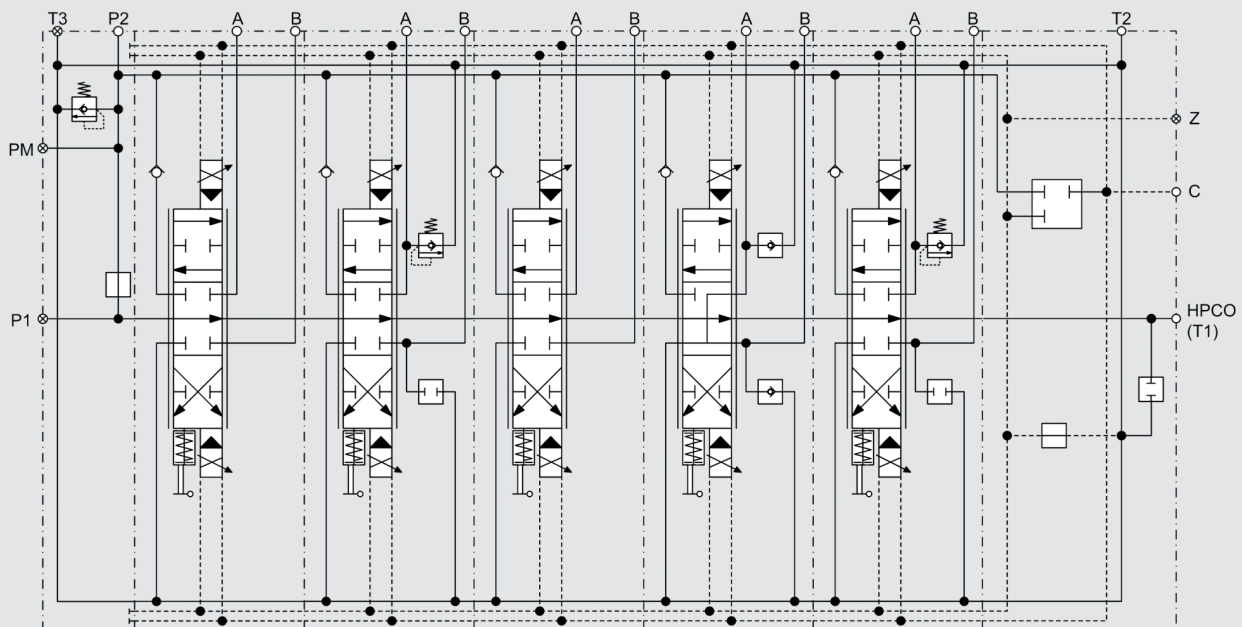

General	RS 165-EH / B0
Inlet plate	P15 / 230F / 0
1. Working section	BP4E / 12AA / EHB1A-1
2. Working section	SP4E / 11AA / 250F – P / EHB1A-1
3. Working section	BP4E / 12AA / EHB1A-1
4. Working section	SP4E / 44AA / A – A / EHB1A-1
5. Working section	SP4E / 11AA / 250F – P / EHB1A-1
End plate	E5E1 / ZH

Note

The information in this brochure relates to the operating conditions and applications described.

For applications and operating conditions not described, please contact the relevant technical department.

Subject to technical and other changes.



Nordhydraulic

HYDAC INTERNATIONAL

Head office
HYDAC INTERNATIONAL
GMBH

Industriegebiet
66280 Sulzbach/Saar
Germany

Tel.: +49 6897 509-01
Fax: +49 6897 509-577

E-mail: mobilevalves@hydac.com
Internet: www.hydac.com