

## ANSI Flange Ball Valve KHBF / KHMF

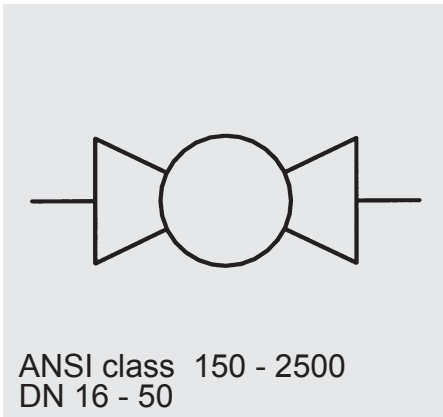
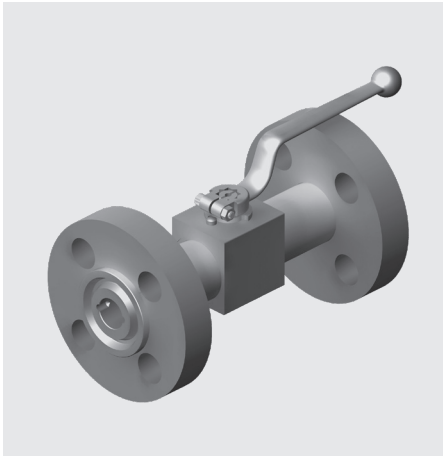

### Model code

(also order example)

**KHBF 16 A0150 ... 11141 06 X ...**

### Designation

KHBF = Block-type ball valve DN 16 – 25  
KHMF = Sleeve-type ball valve DN 16 – 50

### Nominal size

### Pressure range ANSI class

150 220 psi / 15 bar  
300 574 psi / 40 bar  
400 768 psi / 54 bar  
600 1151 psi / 81 bar  
900 1725 psi / 121 bar  
1500 2876 psi / 202 bar  
2500 4792 psi / 337 bar

### Sealing surface

... = Smooth seal face (no details required)  
RTJ = Seal face with O-ring

### Materials

*Housing, connection adapters*

1 = Steel  
3 = Stainless steel (1.4571)

*Ball, control spindle*

1 = Steel  
3 = Stainless steel (1.4571)

*Ball seal*

1 = POM (polyacetal)

*Soft seal*

4 = FKM (Viton)

*Flanges*

1 = Steel  
3 = Stainless steel (1.4571)

(other materials on request)

### Handle

06 = Steel bolt-on handle, cranked

### Series

(determined by manufacturer)

### Surface protection

... = Phosphate-plated (no details required)  
A = Zinc-plated, chrome (VI)-free

## Dimensions

### KHBF

with O-ring groove (RTJ) with smooth seal face (RF)

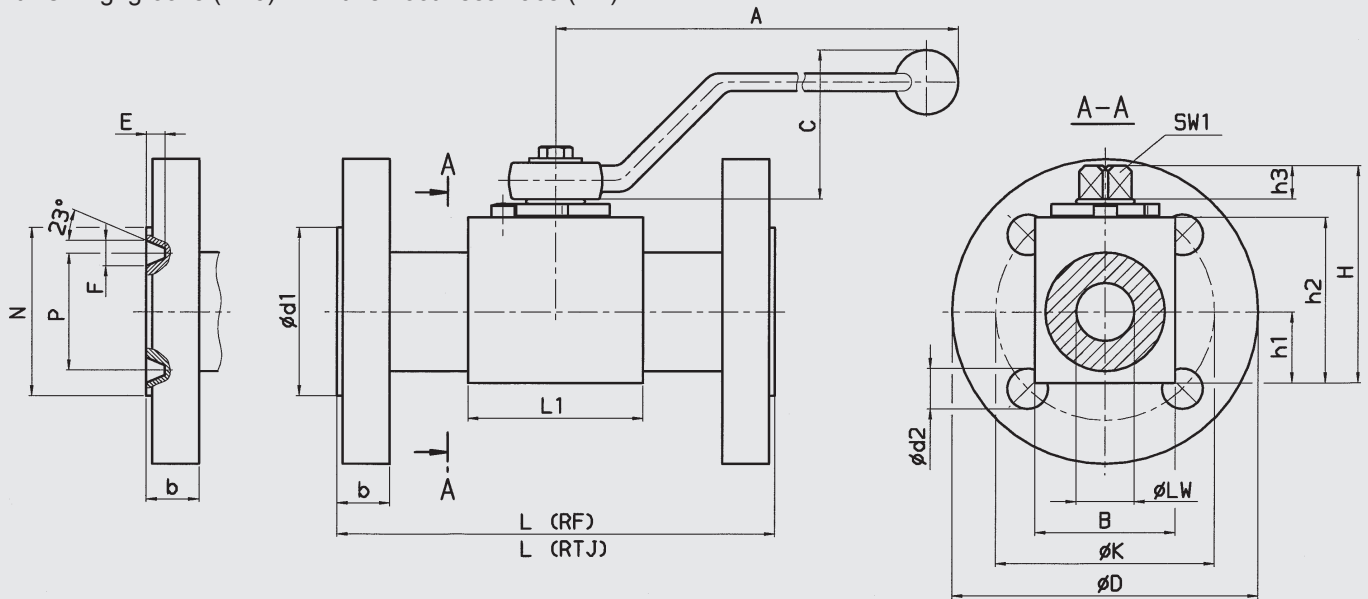

### KHMF

with O-ring groove (RTJ) with smooth seal face (RF)

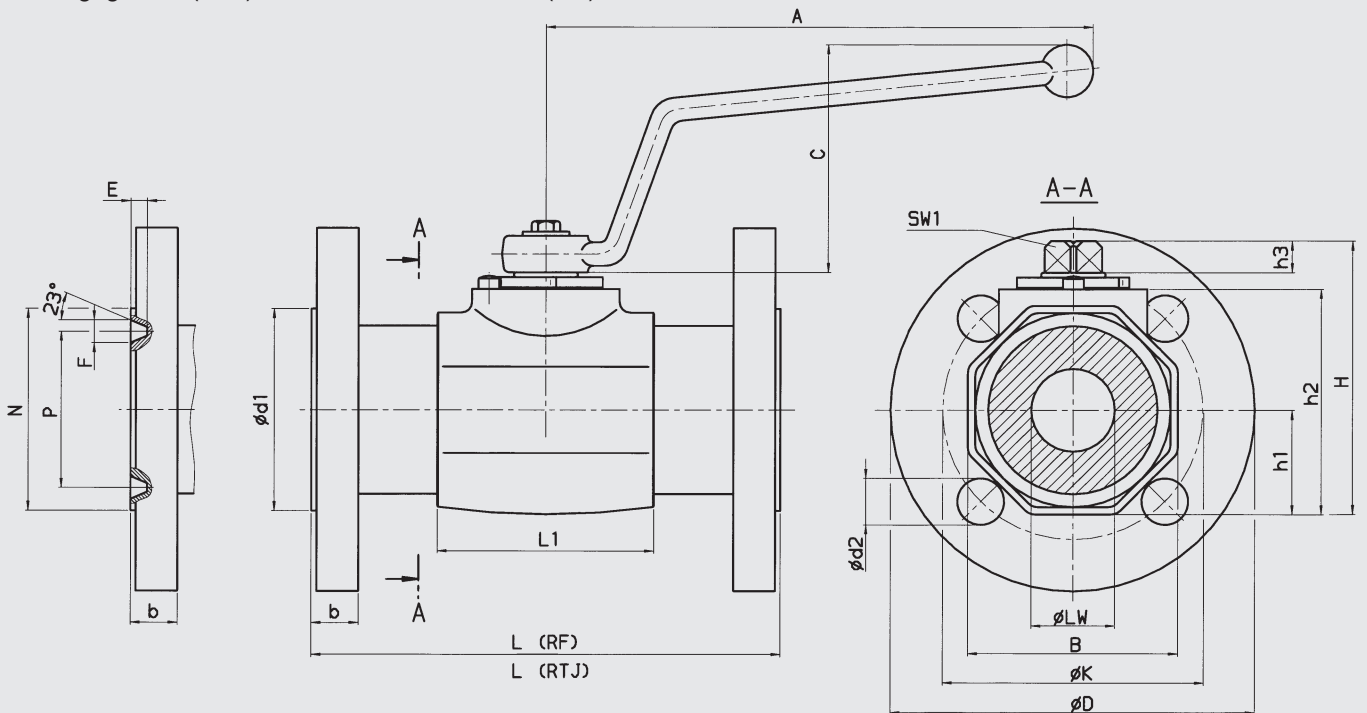

Type of constr.	Housing dimensions												PN (ball valve) [bar]
	Type	DN	LW	L1	B	H	h1	h2	h3	SW1	A	C	
Block housing DN16-25 (steel)	KHBF-16	1/2"	15	47	38	62	19	45	11	12	169	59	400
	KHBF-20	3/4"	20	60	48	75	24.5	57	11	14	169	59	350
	KHBF-25	1"	25	65	57	81.5	28.5	64	11	14	169	59	350
Sleeve housing DN16-50 (stainless steel) DN32-50 (steel)	KHMF-16	1/2"	15	45.8	45	66.5	22.5	48.5	11	12	169	59	400
	KHMF-20	3/4"	20	58.3	55	78	27.5	60	11	14	169	59	350
	KHMF-25	1"	25	63.5	60	83.5	30	65.5	11	14	169	59	350
	KHMF-32	1 1/4"	30	84	75	103	38	85	12	17	228	80	350
	KHMF-40	1 1/2"	38	91	85	114	43	96	12	17	228	80	350
KHMF-50	2"	48	100	105	131.5	53	113	12	17	228	80	350	

**Flange dimensions ANSI class 150**

DN	L (RF)	L (RTJ)	D	d1	d2	k	b	z*	N	P	F	E	Weight (kg)
16 - 1/2"	108	–	88.9	35.1	15.8	60.5	11.2	4	–	–	–	–	1.8
20 - 3/4"	117.4	–	98.6	42.9	15.8	69.9	12.7	4	–	–	–	–	2.9
25 - 1"	127	139.7	108	50.8	15.8	79.2	14.2	4	63.5	47.6	8.7	6.4	4.0
32 - 11/4"	139.7	152.4	117.3	63.5	15.8	88.9	15.7	4	73.2	57.2	8.7	6.4	6.4
40 - 11/2"	165.1	177.8	127	73.2	15.8	98.6	17.5	4	82.6	65.1	8.7	6.4	7.5
50 - 2"	177.8	190.5	152.4	91.9	19	120.7	19	4	101.6	82.6	8.7	6.4	11.1

**Flange dimensions ANSI class 300**

DN	L (RF)	L (RTJ)	D	d1	d2	k	b	z*	N	P	F	E	Weight (kg)
16 - 1/2"	139.7	150.9	95.3	35.1	15.8	66.6	14.2	4	50.8	34.1	7.1	5.6	2.2
20 - 3/4"	152.4	165.1	117.4	42.9	19	82.6	15.7	4	63.5	42.9	8.7	6.4	3.9
25 - 1"	165.1	177.8	124	50.8	19	88.9	17.5	4	69.9	50.8	8.7	6.4	5.0
32 - 11/4"	177.8	190.5	133.4	63.5	19	98.6	19	4	79.3	60.3	8.7	6.4	8.3
40 - 11/2"	190.5	203.2	155.5	73.2	22.4	114.3	20.6	4	90.4	68.3	8.7	6.4	9.9
50 - 2"	215.9	231.7	165.1	91.9	19	127	22.4	8	108	82.6	11.9	7.9	12.8

**Flange dimensions ANSI class 400/600**

DN	L (RF)	L (RTJ)	D	d1	d2	k	b	z*	N	P	F	E	Weight (kg)
16 - 1/2"	165.1	163.6	95.3	35.1	15.8	66.6	20.6	4	50.8	34.1	7.1	5.6	2.5
20 - 3/4"	190.5	190.5	117.4	42.9	19	82.6	22.1	4	63.5	42.9	8.7	6.4	4.4
25 - 1"	215.9	215.9	124	50.8	19	88.9	23.9	4	69.9	50.8	8.7	6.4	5.5
32 - 11/4"	228.6	228.6	133.4	63.5	19	98.6	26.9	4	79.3	60.3	8.7	6.4	9.2
40 - 11/2"	241.3	241.3	155.4	73.2	22.4	114.3	28.7	4	90.4	68.3	8.7	6.4	11.1
50 - 2"	292.1	295.2	165.1	91.9	19	127	31.8	8	108	82.6	11.9	7.9	14.7

**Flange dimensions ANSI class 900/1500**

DN	L (RF)	L (RTJ)	D	d1	d2	k	b	z*	N	P	F	E	Weight (kg)
16 - 1/2"	215.9	215.9	120.7	35.1	22.4	82.6	28.7	4	60.5	39.7	8.7	6.4	4.9
20 - 3/4"	228.6	228.6	130.1	42.9	22.4	88.9	31.8	4	66.6	44.5	8.7	6.4	6.7
25 - 1"	254	254	149.4	50.8	25.4	101.6	34.8	4	71.4	50.8	8.7	6.4	9.7
32 - 11/4"	279.4	279.4	158.8	63.5	25.4	111.3	34.8	4	81	60.3	8.7	6.4	13.5
40 - 11/2"	304.8	304.8	177.8	73.2	28.5	124	38.1	4	92	68.3	8.7	6.4	17.4
50 - 2"	368.3	371.4	215.9	91.9	25.4	165.1	44.5	8	124	95.3	11.9	7.9	28.4

**Flange dimensions ANSI class 2500**

DN	L (RF)	L (RTJ)	D	d1	d2	k	b	z*	N	P	F	E	Weight (kg)
16 - 1/2"	263.7	263.7	133.4	35.1	22.4	88.9	36.6	4	65	42.9	8.7	6.4	9.0
20 - 3/4"	273.1	273.1	139.7	42.9	22.4	95.3	38.1	4	73.2	50.8	8.7	6.4	11.5
25 - 1"	307.9	307.9	158.8	50.8	25.4	108	41.4	4	82.6	60.3	8.7	6.4	14.8
32 - 11/4"	349.3	352.3	184.2	63.5	28.5	130.1	44.5	4	101.6	72.2	11.9	7.9	21.9
40 - 11/2"	384.1	387.1	203.1	73.2	31.8	146	50.8	4	114.3	82.6	11.9	7.9	29.5
50 - 2"	450.9	453.9	235	91.9	28.5	171.5	57.2	8	133.4	101.6	11.9	7.9	43.0

z\* = number of fixing holes

**Technical specifications**

Length:	ASME / ANSI - B16.10		
Flange dimensions:	ASME / ANSI - B16.5		
Flange connections:	Rotating flanges		
Mounting position:	Optional		
Ambient temperature:	-10 °C to +80 °C		
Nominal pressure:	up to PN 337 (see pressure range)		
Operating fluids:	Mineral oil to DIN 51524 Part 1 and Part 2 (other fluids on request)		
Temperature of operating fluid:	-10 °C to +80 °C		
<b>Spare parts:</b>	Seal kits available on request		
<b>Accessories:</b>	All ball valves can be supplied with the following options:		Actuator Limit controls Lock

**NOTE**

The information in this brochure relates to the operating conditions and applications described.

For applications and operating conditions not described, please contact the relevant technical department.

Subject to technical modifications.

**HYDAC Accessories GmbH**

Hirschbachstr. 2  
**66280 Sulzbach/Saar**  
 Tel.: +49 (0)6897 - 509-01  
 Fax: +49 (0)6897 - 509-1009  
 Internet: www.hydac.com  
 E-Mail: info@hydac.com

