



FluidMonitoring Module FMM

Description

The FluidMonitoring Module FMM series combines two of HYDAC's condition monitoring products, the ContaminationSensor CS 1000 and the AquaSensor AS 1000, in one system.

It provides the user with a robust and stationary system for online measurement of

- particle contamination and
- water content (e.g. to detect leakage) in hydraulic and lubrication fluids.

The FMM series of blocks have all the necessary connections and are therefore easy to install in existing hydraulic circuits.

Various models are available for use in filtration & cooler/heater circuits, pressure and high pressure applications.

Advantages

- Cost-effective installation
- Critical machine conditions are identified in good time
- Continuous oil condition monitoring
- Condition-based maintenance planning

Technical data

General data	
FMM - O - M - ...	Offline circuits 6 ... 15 bar
FMM - P - S - ...	Pressure circuits 15 ... 300 bar
FMM - P - M - ...	Pressure circuits 15 ... 300 bar
FMM - P - L - ...	Pressure circuits 15 ... 250 / 300 bar
FMM - A - S - ...	Pressure circuits 15 ... 250 bar

FMM - O - M - ... (previously known as: FMM)

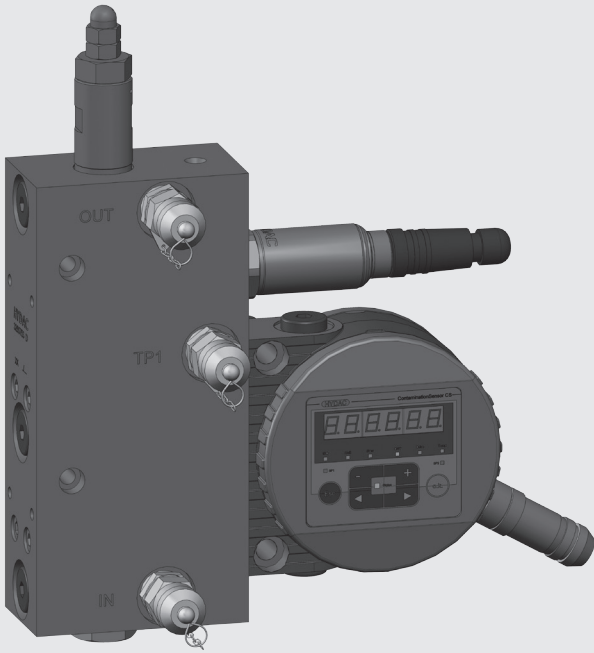

Dimensions

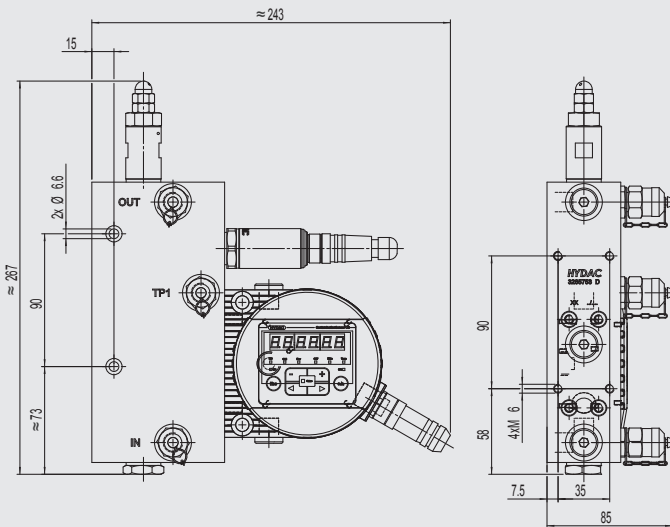

Hydraulic circuit diagram

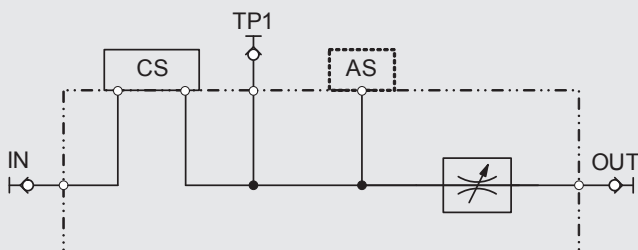

Technical data

Installation position	vertical (flow from bottom to top)
Max. operating pressure	6 ... 15 bar / 87 ... 217 psi
Minimum differential pressure	6 bar / 87 psi (recommended)
Permitted viscosity range	1 ... 350 mm ² /s
Hydraulic connection (IN, OUT)	Test point type 1604 or G 1/4" (ISO 228)
Seal material	FKM / EPDM
Fluid temperature range	0 ... +85 °C / +32 ... +185 °F
Ambient temperature range	-30 ... +80 °C / -22 ... +176 °F
Storage temperature range	-40 ... +80 °C / -40 ... +176 °F
Relative humidity	max. 95%, non-condensing
Weight	4.3 kg

Model code

See last page

Items supplied

- 1 FMM - O - M - ...
- 1 Operating and Maintenance Manual for FMM-O-M
- 1 Manual for additional sensor (optional)
- 1 CD with Operating and Maintenance Manual for CS 1000 in different languages (PDF viewer software required)
- 1 CD with FluMoS light (fluid monitoring software to operate and parameterize the sensor)

Accessories

A wide range of accessories can be found in the brochure "Filter Systems Accessories" (E 7.623...).

FMM - P - S - ... (previously known as: FMMP)

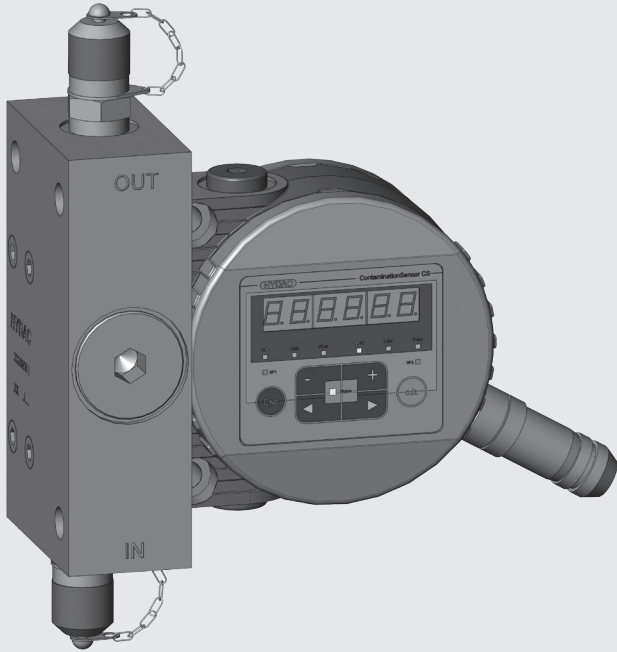

Dimensions

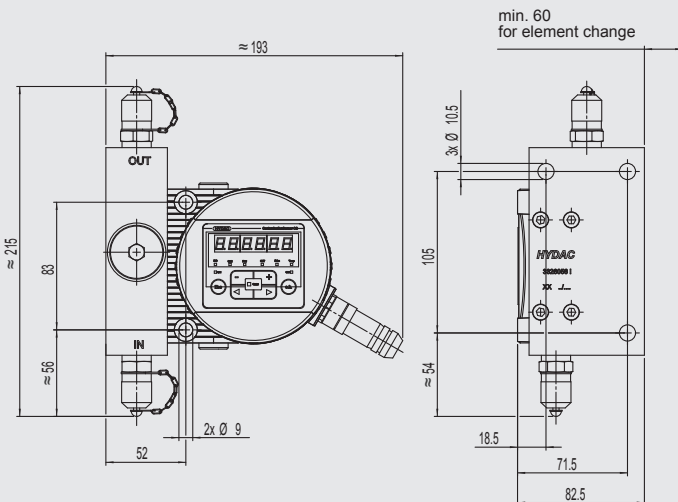

Hydraulic circuit diagram

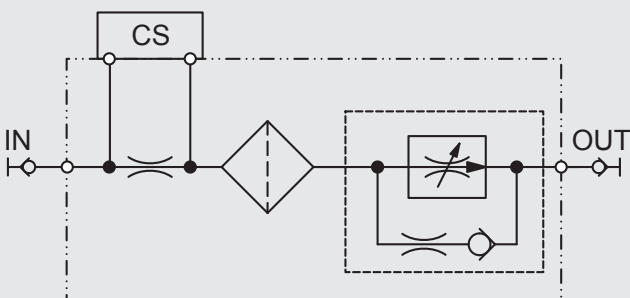

Technical data

Installation position	vertical (flow from bottom to top)
Max. operating pressure	15 ... 300 bar / 217 ... 4350 psi
Minimum differential pressure	15 bar / 217 psi
Permitted viscosity range	1 ... 350 mm ² /s
Hydraulic connection (IN, OUT)	Test point type 1604 or G 1/4" (ISO 228)
Seal material	FKM / EPDM
Fluid temperature range	0 ... +85 °C / +32 ... +185 °F
Ambient temperature range	-30 ... +80 °C / -22 ... +176 °F
Storage temperature range	-40 ... +80 °C / -40 ... +176 °F
Relative humidity	max. 95%, non-condensing
Weight	4.3 kg

Model code

See last page

Items supplied

- 1 FMM - P - S - ...
- 1 Operating and Maintenance Manual for FMM-P-X
- 1 CD with Operating and Maintenance Manual for CS 1000 in different languages (PDF viewer software required)
- 1 CD with FluMoS light (fluid monitoring software to operate and parameterize the sensor)

Accessories

A wide range of accessories can be found in the brochure "Filter Systems Accessories" (E 7.623...).

FMM - P - M - ...

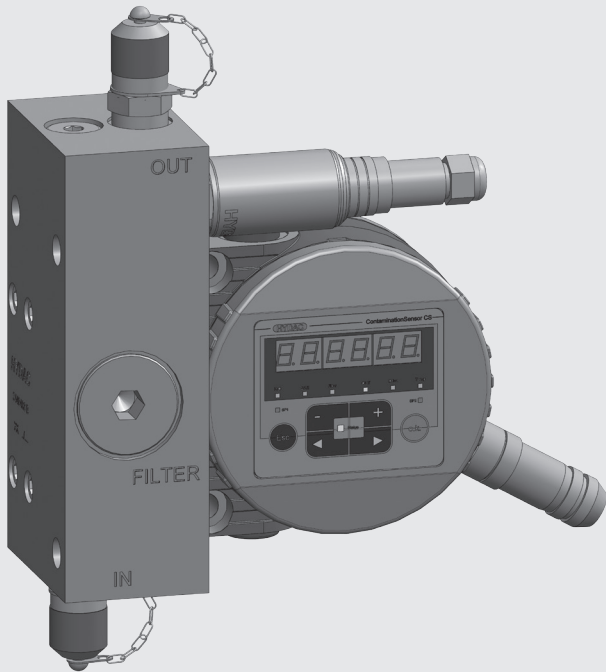

Dimensions

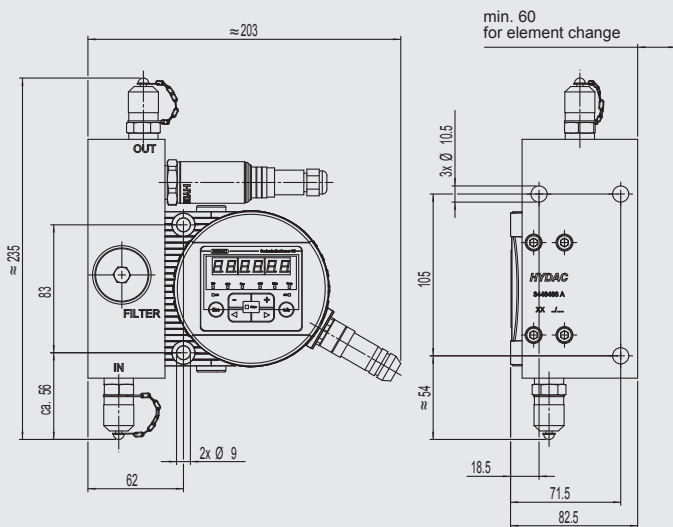

Hydraulic circuit diagram

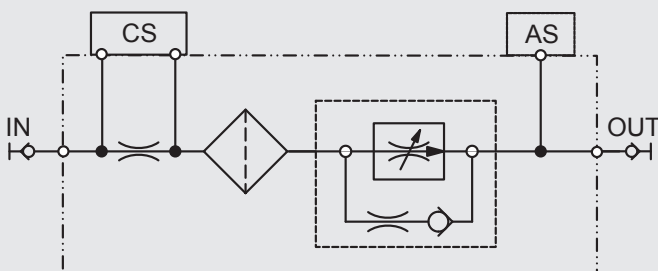

Technical data

Installation position	vertical (flow from bottom to top)
Max. operating pressure	15 ... 300 bar / 217 ... 4350 psi
Minimum differential pressure	15 bar / 217 psi
Permitted viscosity range	1 ... 350 mm ² /s
Hydraulic connection (IN, OUT)	Test point type 1604 or G 1/4" (ISO 228)
Seal material	FKM / EPDM
Fluid temperature range	0 ... +85 °C / +32 ... +185 °F
Ambient temperature range	-30 ... +80 °C / -22 ... +176 °F
Storage temperature range	-40 ... +80 °C / -40 ... +176 °F
Relative humidity	max. 95%, non-condensing
Weight	6.5 kg

Model code

See last page

Items supplied

- 1 FMM - P - M - ...
- 1 Operating and Maintenance Manual for FMM-P-X
- 1 Manual for additional sensor (optional)
- 1 CD with Operating and Maintenance Manual for CS 1000 in different languages (PDF viewer software required)
- 1 CD with FluMoS light (fluid monitoring software to operate and parameterize the sensor)

Accessories

A wide range of accessories can be found in the brochure "Filter Systems Accessories" (E 7.623...).

FMM - P - L - ... (previously known as: FMMHP)

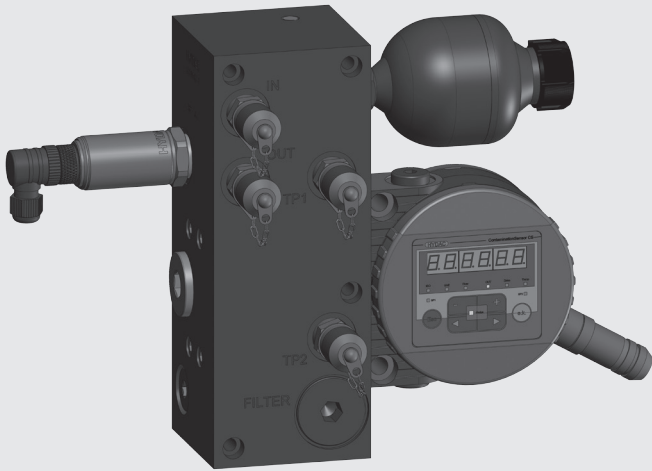

Dimensions

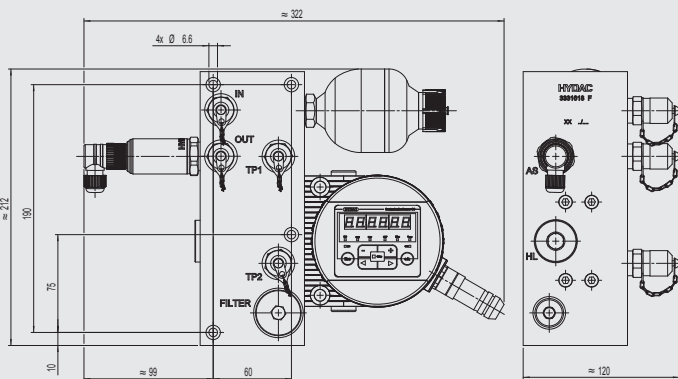

Hydraulic circuit diagram

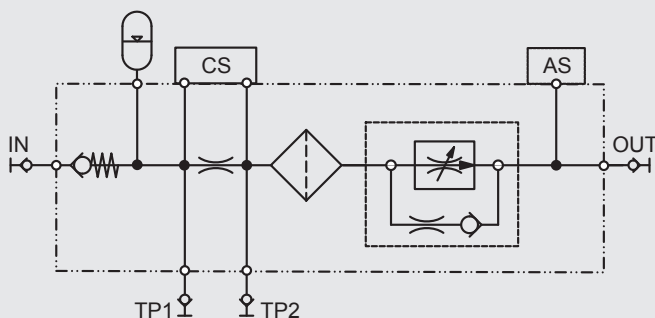

Technical data

Installation position	vertical (flow from bottom to top)
Max. operating pressure without hyd. accumulator	15 ... 300 bar / 217 ... 4350 psi
with hydraulic accumulator	15 ... 250 bar / 217 ... 3625 psi
Minimum differential pressure	15 bar / 217 psi
Permitted viscosity range	1 ... 350 mm ² /s
Hydraulic connection (IN, OUT)	Test point type 1604 or G 1/4" (ISO 228)
Seal material	FKM / EPDM
Fluid temperature range	0 ... +85 °C / +32 ... +185 °F
Ambient temperature range	-30 ... +80 °C / -22 ... +176 °F
Storage temperature range	-40 ... +80 °C / -40 ... +176 °F
Relative humidity	max. 95%, non-condensing
Weight	12.5 kg

Model code

See last page

Items supplied

- 1 FMM - P - L - ...
- 1 Operating and Maintenance Manual for FMM-P-L
- 1 Manual for additional sensor (optional)
- 1 CD with Operating and Maintenance Manual for CS 1000 in different languages (PDF viewer software required)
- 1 CD with FluMoS light (fluid monitoring software to operate and parameterize the sensor)

Accessories

A wide range of accessories can be found in the brochure "Filter Systems Accessories" (E 7.623...).

FMM - A - S - ... - 1 - ...

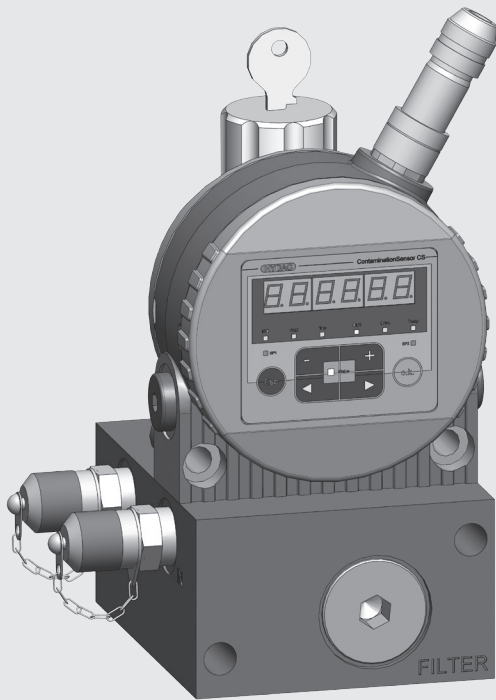

FMM - A - S - ... - 2 - ...

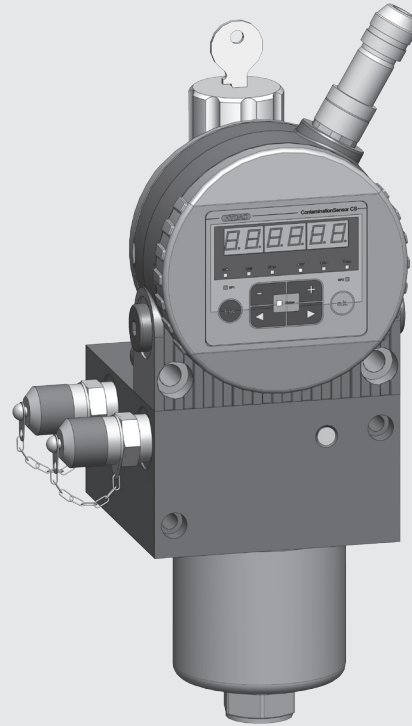

Dimensions

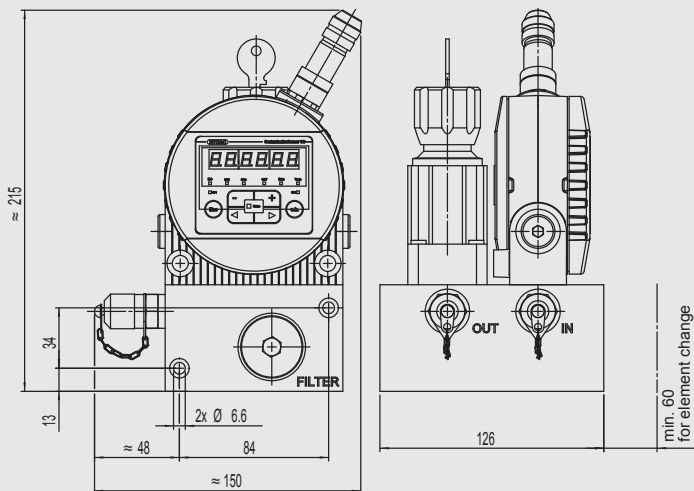

Dimensions

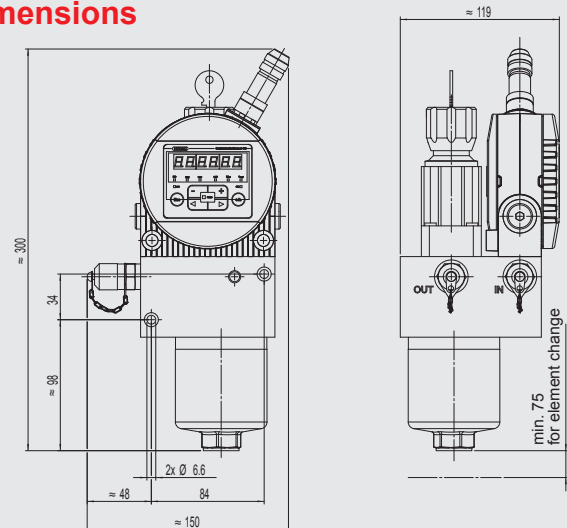

Hydraulic circuit diagram

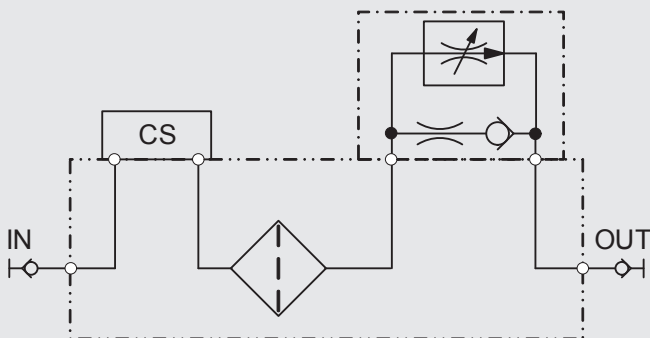

Technical data

Installation position	horizontal
Max. operating pressure	15 ... 250 bar / 217 ... 3625 psi
Minimum differential pressure	15 bar / 217 psi
Permitted viscosity range	10 ... 800 mm ² /s
Hydraulic connection (IN, OUT)	Test point type 1604 or G 1/4" (ISO 228)
Seal material	FKM / EPDM
Fluid temperature range	0 ... +85 °C / +32 ... +185 °F
Ambient temperature range	-30 ... +80 °C / -22 ... +176 °F
Storage temperature range	-40 ... +80 °C / -40 ... +176 °F
Relative humidity	max. 95%, non-condensing
Weight	8.0 kg FMM-A-S-...-1-... 7.8 kg FMM-A-S-...-2-...

Model code

See last page

Items supplied

- 1 FMM - A - S - ...
- 1 Operating and Maintenance Manual for FMM-A-S
- 1 CD with Operating and Maintenance Manual for CS 1000 in different languages (PDF viewer software required)
- 1 CD with FluMoS light (fluid monitoring software to operate and parameterize the sensor)

Accessories

A wide range of accessories can be found in the brochure "Filter Systems Accessories" (E 7.623...).

Model code

FMM - O - M - 0 - CS 1 2 2 0 - A - AS - 0 - 0 - 0 / -000

TYPE

FMM = Fluid Monitoring Module

Hydraulic application

- O = Offline (offline circuit, < 15 bar) sensor combination M only
- P = Pressure Line (pressure circuit, > 15 bar)
- A = Adjustable Flow Control Valve (pressure circuit, > 15 bar) sensor combination S only

Sensor combination

- S = CS1000
- M = CS1000 + AS1000 or CS1000 + AS3000 or CS1000 + HydacLab*
- L = CS1000 + AS1000 + HydacLab* or CS1000 + AS3000 + HydacLab*

Seal

- 0 = FKM (FPM/Viton®)
- 1 = EPDM
(not for hydraulic accumulator)

Contamination Sensor CS1000 Series

- CS 1210 = ISO / SAE, without display (FKM)
- CS 1220 = ISO / SAE, with display (FKM)
- CS 1310 = ISO / SAE / NAS, without display (FKM)
- CS 1320 = ISO / SAE / NAS, with display (FKM)
- CS 1211 = ISO / SAE, without display (EPDM)
- CS 1221 = ISO / SAE, with display (EPDM)
- CS 1311 = ISO / SAE / NAS, without display (EPDM)
- CS 1321 = ISO / SAE / NAS, with display (EPDM)

Analogue interface of the CS1000

- A = 4 ... 20 mA
- B = 0 ... 10 VDC

Additional sensor

- Z = without
- AS = AS1000
- AS3 = AS3000
- Z(AS) = set up for AS1000 / AS3000
- Z(HL) = set up for HydacLab

Hydraulic accumulator

- 0 = without accumulator
- 1 = diaphragm accumulator SBO 250-0.075 (40 bar gas pressure) [not available in EPDM]

Filter

- 0 = without filter (only for FMM-O)
- 1 = protective filter (25µm) (for FMM-P, optional for FMM-A)
- 2 = DF60 (5µm) (optional for FMM-A)

Options

- 0 = no options

Modification number

- 000 = modification number

* Set up for HydacLab

Note

The information in this brochure relates to the operating conditions and applications described.

For applications and operating conditions not described, please contact the relevant technical department.

Subject to technical modifications.

HYDAC FILTER SYSTEMS GMBH
Industriegebiet
D-66280 Sulzbach / Saar
Tel.: +49 (0) 6897/509-01
Fax: +49 (0) 6897/509-9046
Internet: www.hydac.com
E-Mail: filtersystems@hydac.com