



Metallic Contamination Sensor MCS 1000 Series

Description

The Metallic Contamination Sensor MCS 1000 monitors metallic particle contamination in lubrication fluid. The particles are detected by inductive measurement whereby a coil system is the core element of the sensor. It detects metallic particles (ferromagnetic Fe and non-ferromagnetic nFe) in the > 70 µm size range.

The MCS 1000 continuously monitors the condition of the system and provides information on any early-stage damage.

The sensor is therefore a reliable tool for condition-based maintenance.

As an option the MCS 1000 series can be supplied with an Ethernet interface. This means that the sensors can easily be connected to existing networks.

Certified by Germanischer Lloyd Industrial Service



GL Wind Order No. 4800/08/41043/254

Advantages

- Detection of early-stage damage, for example, in a gearbox
- Prevents costly turbine downtime
- The perfect complement to optical sensors
- Measurement of metallic particles (ferromagnetic Fe and non-ferromagnetic nFe) > 70 µm
- Measurement result is not affected by air bubbles or liquid contamination in the fluid
- Condition monitoring systems in wind power turbines which have already been certified by GL do not lose their certification if the MCS 1000 is built into the system after certification, as the component itself is certified.

Technical specifications

Hydraulic data	MCS 15xx	MCS 14xx	MCS 13xx
Flow rate	10 ... 200 l/min	2 ... 40 l/min	0.4 ... 8 l/min
Operating pressure	Maximum 20 bar		
Fluid temperature range	-40 ... +85°C		
Inlet / Outlet	Flange connection, SAE 4" to ISO 6162-1	Flange connection, SAE ¾" to ISO 6162-1	Flange connection, SAE ½" to ISO 6162-1
Electrical data			
Supply voltage	9 ... 36 V DC, residual ripple < 10%		
Power consumption	Max. 5 W		
Electrical data			
2 configurable switch outputs (n-switching Power MOSFET, normally-open)	1 x ferromagnetic particles (Fe) 1 x non ferromagnetic particles (nFe) or 1 x ferromagnetic (Fe) + non ferromagnetic (nFe) particles 1 x status signal		
Switching logic	Active Low or Active High		
Length of switching pulse	can be set from 5 ... 200 ms		
Switch outputs	max. 1.5A		
RS485 interface	2 wire, half duplex		
HSI (HYDAC Sensor Interface)	1 wire, half duplex		
Ethernet Interface	10 Base-T / 100 Base-Tx		
General data			
Environmental temperature	-40 ... +70°C		
Diameter sensor cross-section	1"	½"	¼"
Protection class to DIN 40050	IP 67		
Weight	≈ 3.5 kg	≈ 2.5 kg	≈ 3.0 kg
Dimensions L x W x H	83 x 162 x 140 mm	83 x 120 x 120 mm	83 x 120 x 120 mm
Vibration 10 - 58 Hz 58 - 500 Hz	0.75 mm (amplitude) 10 g (acceleration)		
Shock	40 g		
Detection limits			
Ferromagnetic (Fe) particles	> 200 µm (particle with volume equivalent to that of a sphere of given Ø)	> 100 µm	> 70 µm
non-ferromagnetic (nFe) particles	> 550 µm (particle with volume equivalent to that of a sphere of given Ø)	> 300 µm	> 200 µm
Particle rate	> 25/s		

Items supplied

- MCS 1000 series
- O-rings (NBR and FPM)
- Installation and Maintenance Instructions

Accessories

- SAE 4" flange adapter set, for pipe or hose connection, 42L according to ISO 8431-1
Consisting of:
2x flange adapters
2x O-rings
8x hex. head screws
8x washers
8x spring washers
Part No.: 3435426
- SAE 3/4" flange adapter set, for pipe or hose connection, 1/2" according to ISO 8431-1
Consisting of:
2x flange adapters
2x O-rings
8x hex. head screws
Part No.: 3588249
- Flange adapter plate, SAE 4" – SAE 1 1/2"
Part No.: 3442518
- Female connector with 2 m cable, screened, 8-pole, M12x1,
Part No.: 3281220
- Female connector with 5 m cable, screened, 8-pole, M12x1,
Part No.: 3281239
- Extension cable 5 m, female connector 8-pole, M12x1 / male connector 8-pole, M12x1,
Part No.: 3281240
- Female connector with screw terminal, 8-pole, M12x1,
Part No.: 3281243

Model code

MCS 1 5 1 0 - 5 - 0 / 000

- Type** _____
MCS = Metallic Contamination Sensor
- Series** _____
1 = 1000 Series
- Contamination / Sensor cross section** _____
3 = particles > 70 µm / 1/4"
4 = particles > 100 µm / 1/2"
5 = particles > 200 µm / 1"
- Signal technology** _____
1 = 2x switch outputs / RS485 (HSI protocol)
7 = 2x switch outputs / RS485 / ethernet (HSI TCP/IP protocol)
- Media** _____
0 = mineral and synthetic oils (particularly those used in wind energy sector)
- Hydraulic connection** _____
1 = flange connection, SAE 1/2" to ISO 6162-1
2 = flange connection, SAE 3/4" to ISO 6162-1
5 = flange connection, SAE 4" to ISO 6162-1
- Electrical connection** _____
0 = M12x1, 8-pole
1 = M12x1, 8-pole and ethernet M12x1, 4-pole, coding D to IEC61076-2-101
- Modification number** _____
000 = standard
TTV = external O-rings in low temperature FPM (Viton®)

Dimensions for MCS 15xx (in mm)

Flange connection, SAE 4" to ISO 6162-1

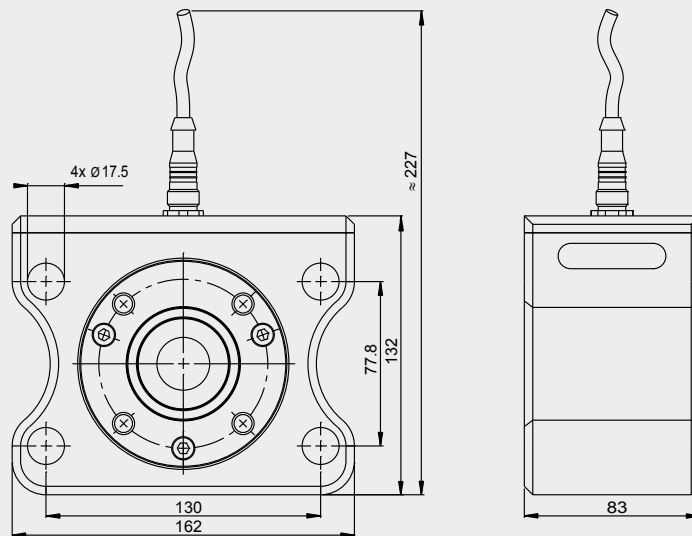

MCS with accessory flange adaptor for pipe or hose connection 42L to ISO8431-1

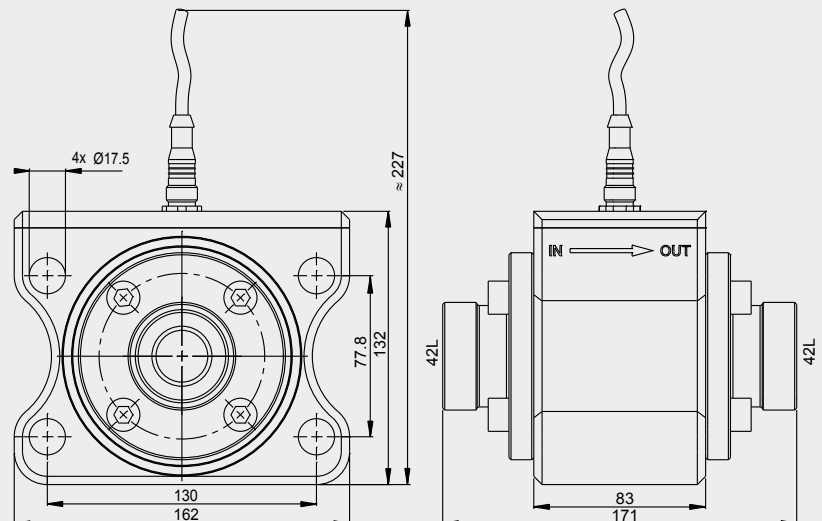

Mounting hole pattern

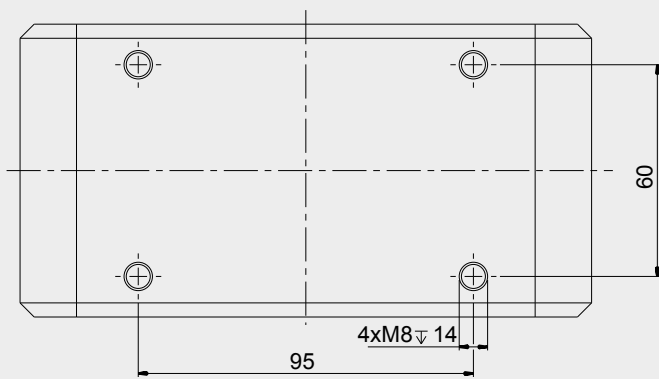

Dimensions with Ethernet connection for MCS 15xx (in mm)

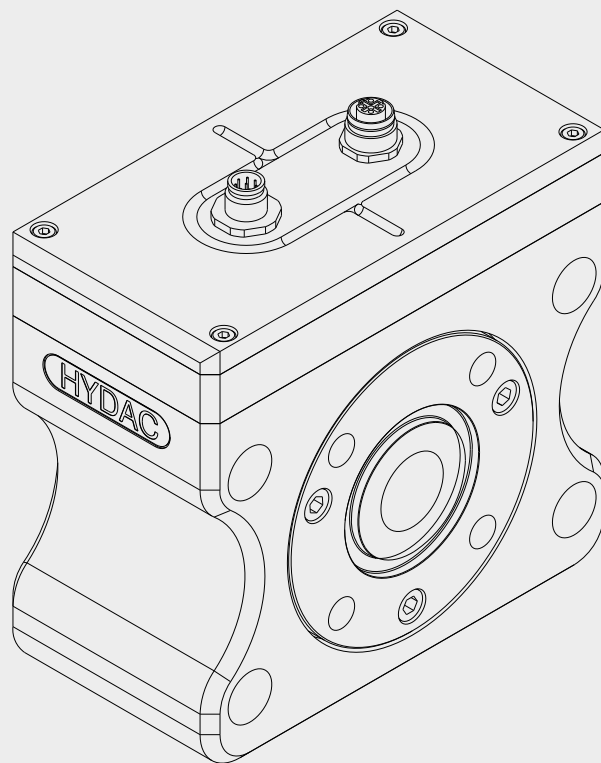
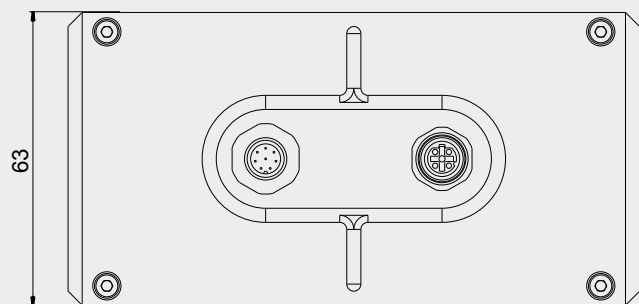
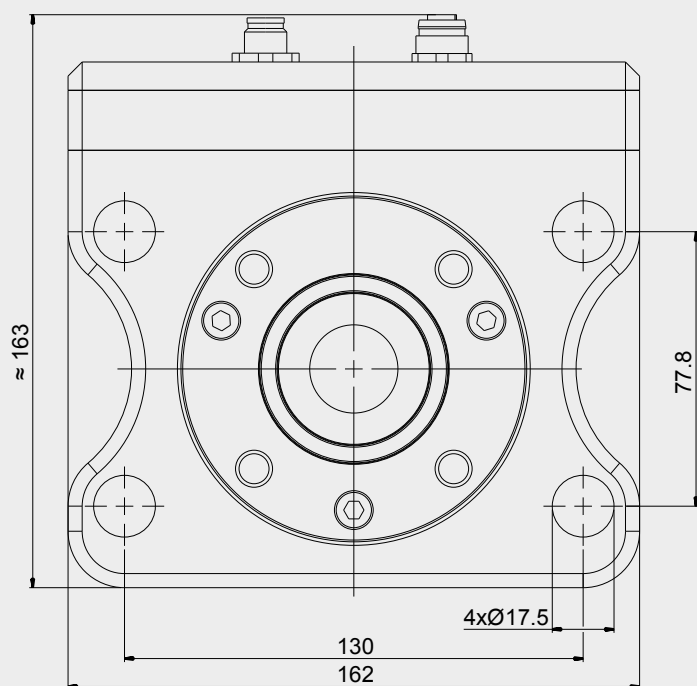

Dimensions for MCS 14xx (in mm)

Flange connection, SAE 3/4" to ISO 6162-1

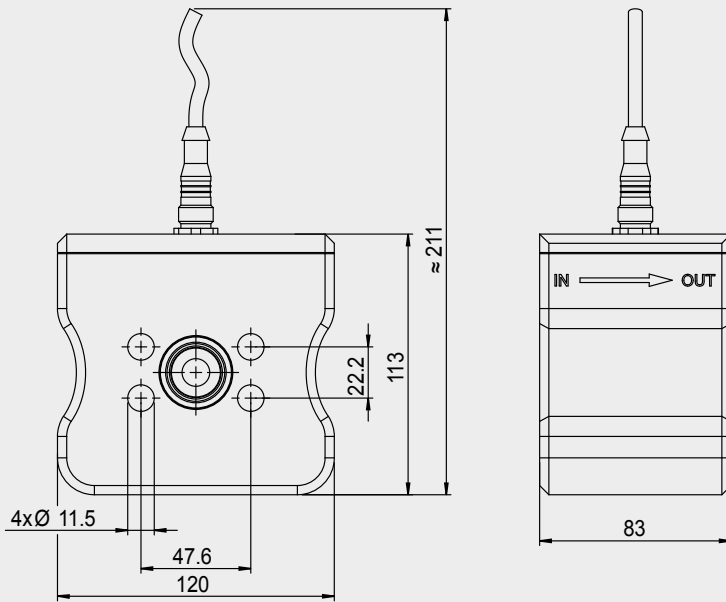

MCS with accessory flange adaptor for pipe or hose connection 1/2" to ISO8431-1

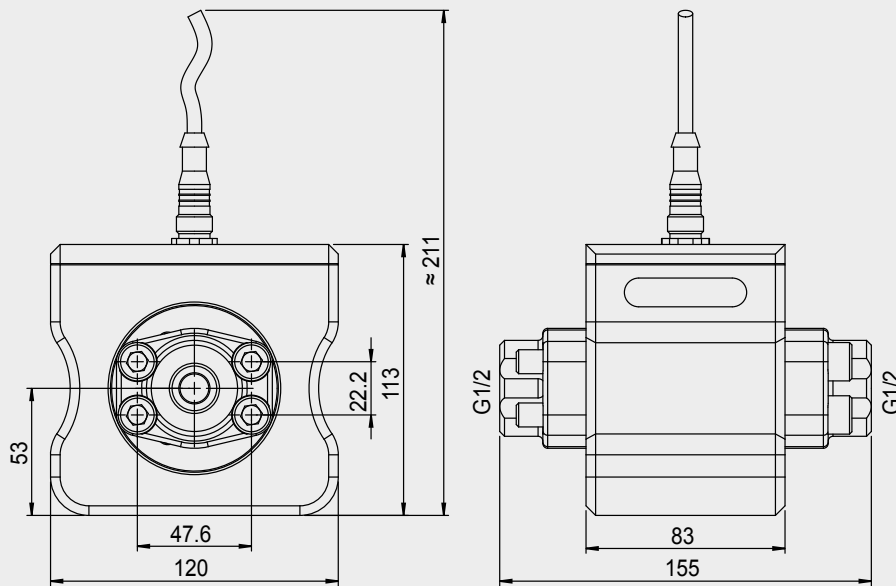

Certified by Germanischer Lloyd Industrial Service

The Metallic Contamination Sensor was certified in February 2010 as an "add on" for condition monitoring systems in wind power turbines.

The certification was carried out by **Germanischer Lloyd Industrial Services GmbH**.

GL Renewables certification

GL is one of the leading certification authorities in the wind energy sector, performing tests, certification procedures and appraisals for wind power turbines and their components.



GL Wind Order No. 4800/08/41043/254

What is the basis of the certification?

The Guideline for the Certification of Condition Monitoring Systems (CMS) for Wind Turbines, Edition 2007

This guideline states that the sensors must be capable of distinguishing between ferromagnetic and non-ferromagnetic particles and that installation in the cooling filtration circuit must be upstream of the filter.

Mounting hole pattern

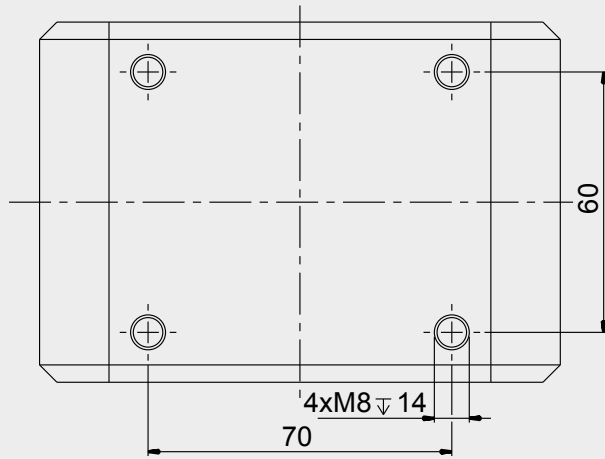

Dimensions with Ethernet connection for MCS 14xx (in mm)

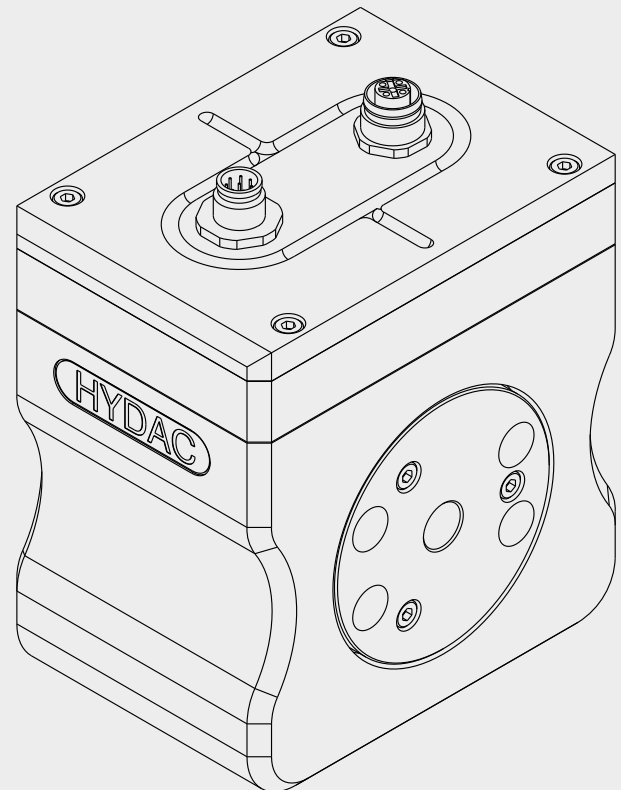
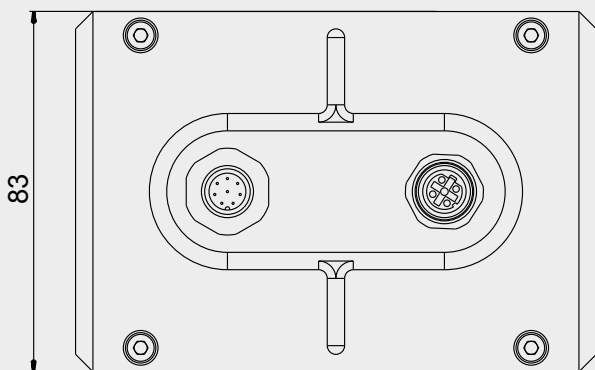
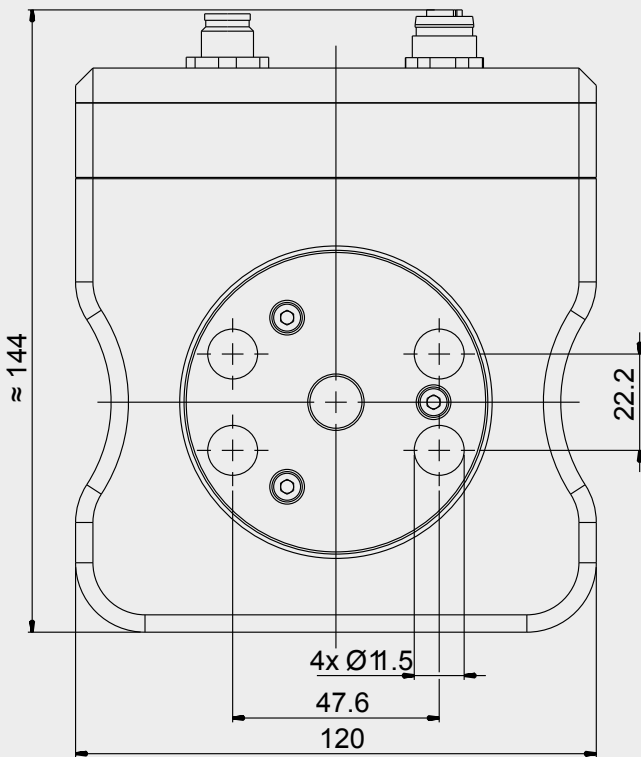

Dimensions MCS 13xx (in mm)

Flange connection, SAE 1/2" to ISO 6162-1

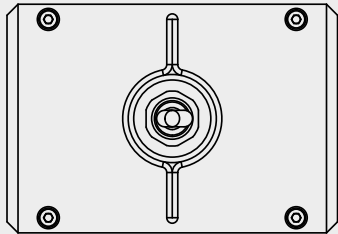
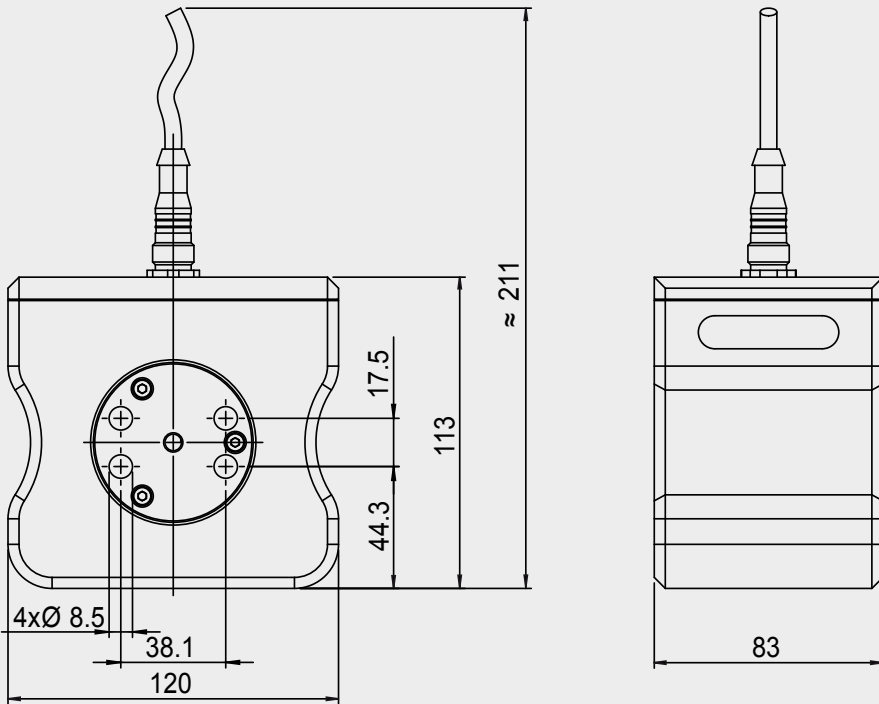

MCS with accessory flange adaptor
for pipe or hose connection 1/2" to ISO8431-1

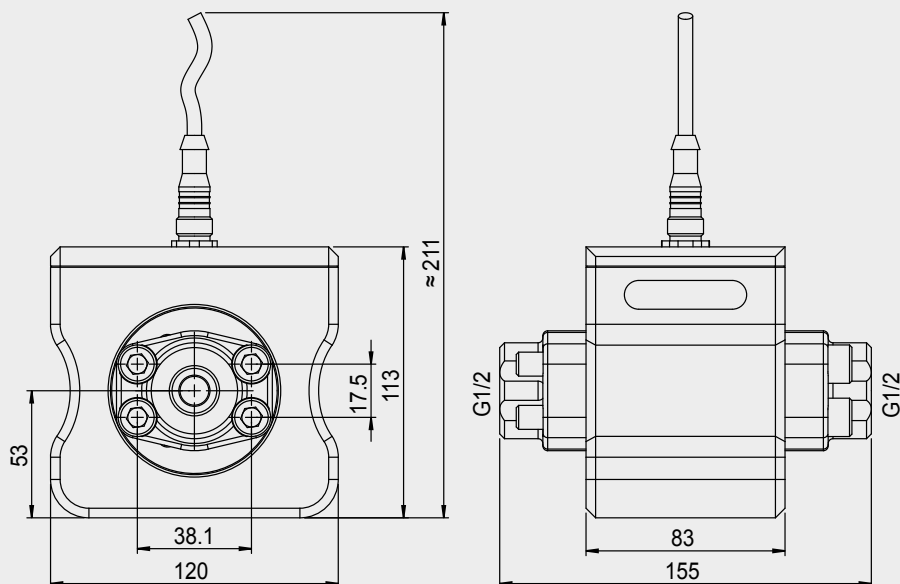

Mounting hole pattern

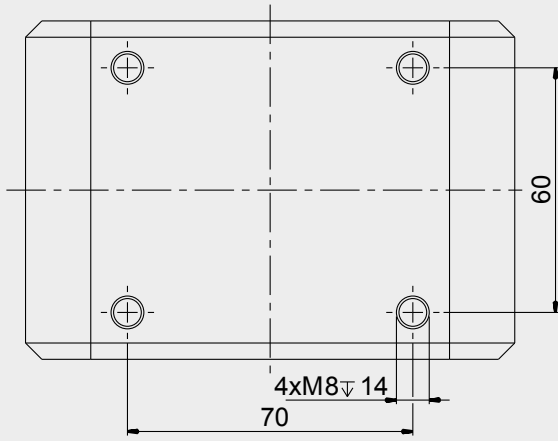

Dimensions with Ethernet for MCS 13xx (in mm)

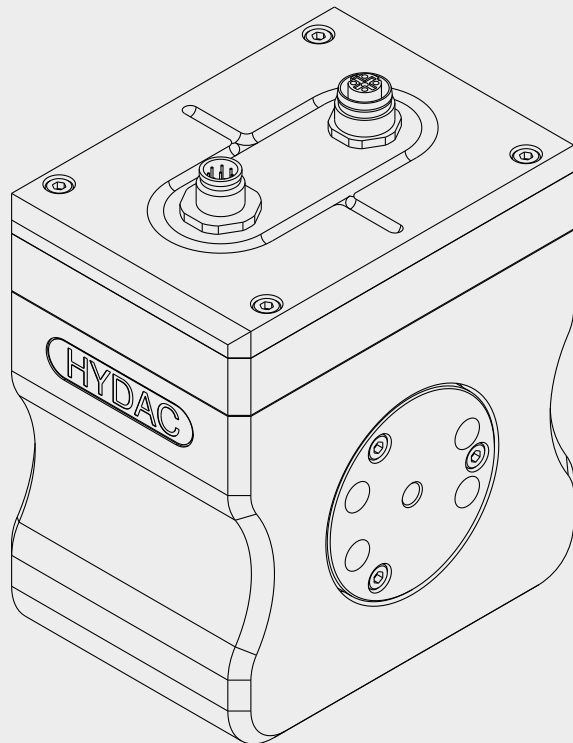
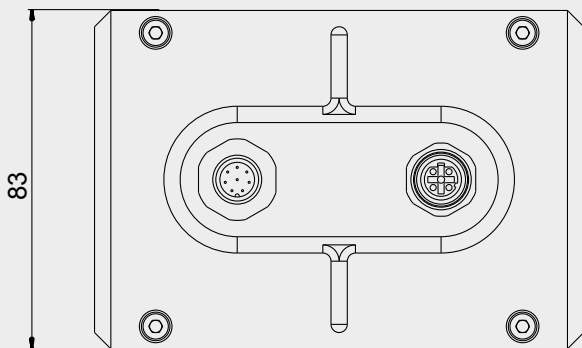
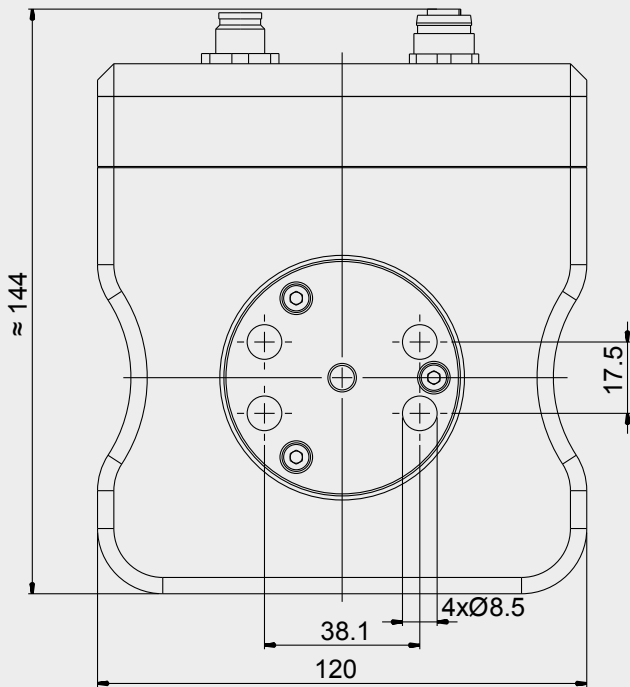

Note

The information in this brochure relates to the operating conditions and applications described.

For applications and operating conditions not described, please contact the relevant technical department.

Subject to technical modifications.

HYDAC FILTER SYSTEMS GMBH

Justus-von-Liebig-Straße
D-66280 Sulzbach / Saar
Tel.: +49 (0) 6897/509-01
Fax: +49 (0) 6897/509-9046
Internet: www.hydac.com
E-Mail: filtersystems@hydac.com