



SensorMonitoring Unit SMU 1200 Series

Description

The SensorMonitoring Unit SMU1200 is a display unit for HYDAC fluid sensors and is designed to display and store measured data.

The following combinations of fluid sensors can be connected directly:

- ContaminationSensor CS1000 and AquaSensor AS1000
- MetallicContamination Sensor MCS 1000 and AquaSensor AS 1000

Advantages

- Simple installation in parallel to the customer system (Hydac Sensor Interface HSI for SMU1200, transfer of the sensor's own analogue and switching outputs).
- Simple installation using the magnetic holder or DIN rails.
- High protection class IP67. Installation in a switch cabinet is not necessary
- Plug & Work unit including the 5m connection cable required for direct connection of the sensors (sensor connections via M12x1 male connectors, no programming necessary).
- The measured data is displayed on the large display.
- Simple keypad operation.
- Data is stored in the SMU with a date and time stamp.
- Measured values can be read from the standard USB memory stick supplied, via the USB master port, or via Bluetooth using HYDAC FluMoS mobile (Android).
- Simple data processing and data evaluation using MS-Excel or Hydac FluidMonitoring Software FluMoS ('Light Version' available as freeware from www.hydac.com).
- Program restarts independently once voltage is restored; no loss of measured data.

Technical specifications

General data	
Installation position	Optional
Self diagnostics	Continuously with error indication on display
Display	LED, 6/4/4-digit, each with 17 segments
Accuracy of the real-time clock	± 5 s/day / ± 0.5 h/year
Clock buffer	≈ 20 years
Drop test (to IEC/EN 60068-2-31)	Drop height 50 mm
Ambient temperature	0 °C ... +55 °C / +32 °F ... +131 °F
Storage temperature range	-40 °C ... +80 °C / +40 °F ... +176 °F
Relative humidity	maximum 95%, non-condensing
IP class	IP 67
Weight	≈ 1 kg
Electrical data	
Supply voltage	12 ... 24 V DC (±20%), residual ripple ≤ 10% The SMU must not be used with on-board supply systems without load dump protection of maximum 30 V DC.
Max. power and current consumption	15 Watt; 1250 mA
Protection class	III (safety extra-low voltage)
Interfaces	
USB Master port	USB Type A
HSI (HYDAC Sensor Interface)	1-wire half duplex
	or
Ethernet interface	10 Base-T / 100 Base-Tx
	and / or
Bluetooth	Version 1.2 / Class 3
Internal measurement data memory	
Measurement interval 60 s	> 42 days
Measurement interval 60 min	> 2530 days

Model code

SMU 1 2 6 0 - TU - 00 / 000

Type _____
SMU = SensorMonitoring Unit

Series _____
1 = 1000 Series

Data input _____
2 = Digital

Interface _____
6 = HSI + USB Master
7 = Ethernet + USB Master

Options _____
0 = standard
1 = Bluetooth

Supply voltage _____
TU = 12 ... 24 V DC

Sensor combination _____

A	B
00 = CS1000	AS1000
10 = MCS1000	AS1000

Customer modification number _____
000 = Customer modification number

Items supplied

- 1 x SMU 1200 Series
- 1 x USB memory stick
- 1 x connecting cable 5 pole with flying leads for voltage supply, L= 5m
- 2 x connecting cables according to the combination of measurement sensors, L = 5m
- 1 x FluMoS Light CD
- 1 x operating manual
- 1 x DIN rail, L = 20 cm to DIN EN 60715 TH35

Accessories

- Power supply PS5, 100-240 V AC / 50-60 Hz / 1.1 A → 24 V DC / 1000 mA, Cable length = 1.8 m, Part no.: 3399939

Connection cable – ETHERNET

- ZBE 45-05, length 5 m
M12x1 → RJ45, Patch 3346100
- ZBE 45-10, length 10 m
M12x1 → RJ45, Patch 3346101
- ZBE 46-05, length 5 m
M12x1 → RJ45, Cross 3346102
- ZBE 46-10, length 10 m
M12x1 → RJ45, Cross 3346103

Dimensions

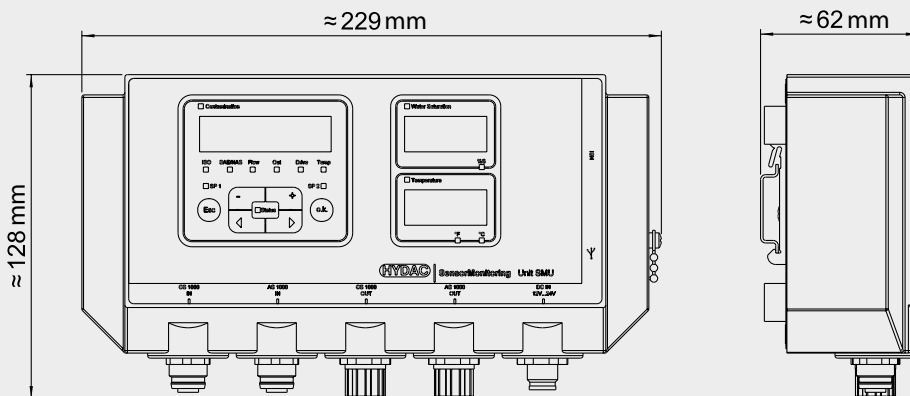

Note

The information in this brochure relates to the operating conditions and applications described.

For applications and operating conditions not described, please contact the relevant technical department.

Subject to technical modifications.

HYDAC FILTER SYSTEMS GMBH

Justus-von-Liebig-Straße

D-66280 Sulzbach / Saar

Tel.: +49 (0) 6897/509-01

Fax: +49 (0) 6897/509-9046

Internet: www.hydac.com

E-Mail: filtersystems@hydac.com