



## Contamination Sensor Module CSM 2000 Series

### Description

The Contamination Sensor Module CSM 2000 is an online condition monitoring system for recording solid particle contamination in hydraulic and lubrication fluids containing a high proportion of air bubbles.

Air bubble suppression is used to dissolve the air bubbles so that they are not detected as particles.

In addition, it is the ideal solution for analyzing the particle content of fluids, independently of the rest of the hydraulic system.

As an option, other condition monitoring sensors such as the Hydac AquaSensor can be incorporated.

### Applications

- Lubrication oil system in paper, steel and energy sectors
- For preventive, pro-active maintenance
- Monitoring of component cleanliness on test rigs
- Monitoring of oil cleanliness in reservoirs

### Advantages

- Cost-effective, system solution
- Numerous data interfaces provide, amongst other things, communication via WLAN, intranet or internet
- Online monitoring of the oil cleanliness with alarm function to indicate:
  - ingress of, and increase in contamination
  - increase in contamination as components start to wear
  - when there are filtration problems
- Verification of cleanliness on test rigs
- Verification of changes in the oil cleanliness as a result of inadequate servicing.

### Technical specifications

	CSM2xxx-1	CSM2xxx-2	CSM2xxx-4
<b>Operating pressure</b>			
P <sub>in</sub> (INLET)	-0.4 ... 0.5 bar	-0.4 ... 120 bar	-0.4 ... 80 bar
P <sub>out</sub> (OUTLET)	max. 5 bar	max. 5 bar	max. 5 bar
P <sub>out</sub> (leakage line)	–	max. 0.5 bar	–
<b>Hydraulic connections</b>			
INLET	G 1/4, ISO 228	G 1/4, ISO 228	G 1/4, ISO 228
OUTLET	G 1/4, ISO 228	G 1/4, ISO 228	G 1/4, ISO 228
LEAKAGE	–	G 1/4, ISO 228	–
Total flow rate	≈ 100 ml/min	≈ 180 ml/min	≈ 250 ml/min
Permissible operating viscosity	10 ... 3,000 mm <sup>2</sup> /s	10 ... 3,000 mm <sup>2</sup> /s	10 ... 1,000 mm <sup>2</sup> /s
Permitted operating viscosity range	10 ... 1,000 mm <sup>2</sup> /s	10 ... 1,000 mm <sup>2</sup> /s	10 ... 800 mm <sup>2</sup> /s
Pump type	Gear pump		
Permitted fluids	Hydraulic and lubrication fluids based on mineral oil		
Power consumption (motor pump unit)	0.18 kW @ 50 Hz 0.21 kW @ 60 Hz		
Permitted fluid temperature	0 ... +70°C		
Ambient temperature	0 ... +40°C		
Storage temperature	-40 ... +80°C		
Relative humidity	max. 90%, non-condensing		
IP class	IP55		
Weight when empty	≈ 22 kg		
<b>Contamination Sensor:</b>			
Self diagnostics	Continuous with error display via relays and serial interface		
Measurement range (calibrated)	ISO 13/11/10 ... 23/21/18. Display range is from class ISO 12/10/09 to class ISO 25/23/21.		
Supply voltage	24 V DC ± 25%		
Power consumption	25 Watt max.		
Electrical data	- Output for Contamination Sensor Display - 3 relay outputs: 1 x "ready" relay 2 x "limit" relays - PLC output - Additional electrical output (see model code)		

## Model code

**CSM 2 2 3 0 - 1 - 1 W/N/X60/O60 -**

### Type

CSM ContaminationSensor Module

### Resolution of ContaminationSensor

2 = 4 particle size channels

### Contamination codes

0 = ISO 4406:1987 | >5 µm; >15 µm;  
>25 µm; >50 µm

NAS 1638 | 5-15 µm; 25-50 µm; 50 µm

1 = ISO 4406:1991 | >2 µm; >5 µm; >15 µm; >25 µm

NAS 1638 | 2-5 µm; 5-15 µm; 15-25 µm; >25 µm

2 = ISO 4406:1999 + SAE AS 4059 (D) | >4 µm<sub>(c)</sub>;  
>6 µm<sub>(c)</sub>; >14 µm<sub>(c)</sub>; >21 µm<sub>(c)</sub>

### Housing of ContaminationSensor

3 = standard

### Fluids

0 = for standard mineral oils

### Hydraulic version

1 = gear pump, standard

2 = gear pump, with increased inlet pressure, with leakage line

4 = gear pump, with increased inlet pressure, no leakage line, magnetic drive

### Electrical output of ContaminationSensor

0 = RS232 (DIN 66348 Protocol)

1 = Analogue output (4-20 mA)

2 = RS485 (DIN 66348 Protocol)

5 = Ethernet (IEEE 802.3 TCP/IP)

### Supply voltage of motor pump unit

W/N/X60/O60 = 230 V, 50 Hz, 3Ph / 265 V, 60 Hz, 3Ph, delta connection  
400 V, 50 Hz, 3Ph / 460 V, 60 Hz, 3Ph, star connection

N/AB/N60/AB60 = 400 V, 50 Hz, 3Ph / 400 V, 60 Hz, 3Ph, delta connection  
690 V, 50 Hz, 3Ph / 690 V, 60 Hz, 3Ph, star connection

other voltages on request!

### Supplementary details

no details = standard

AS = with AquaSensor AS 1000

PKZ = on/off switch with motor protection, 10m cable, male connector 3 phase 16A

## Items supplied

- CSM 2000
- Programming cable
- Pressure gauge with adapter
- Operating and maintenance instructions CSM 2000
- CE conformity or incorporation declaration CSM 2000 (depending on model)
- Operating and maintenance instructions CS 2000
- Calibration certificate CS 2000
- CD with FluMoS light (fluid monitoring software to operate and parameterize the sensor)
- Software Manual FluMoS

## Hydraulic circuit diagram

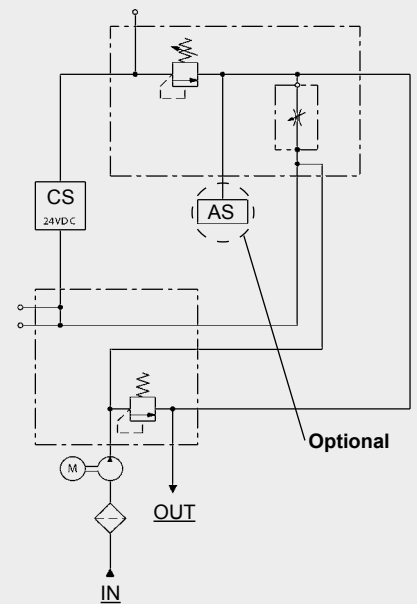

## Dimensions with on/off switch (mm)

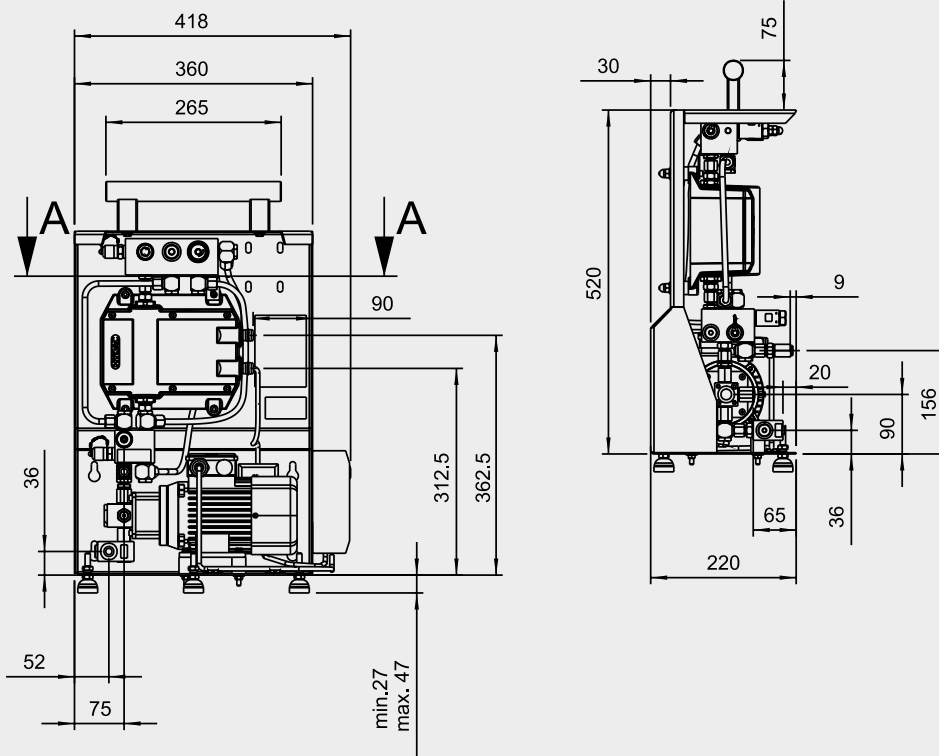

## Dimensions without on/off switch (mm)

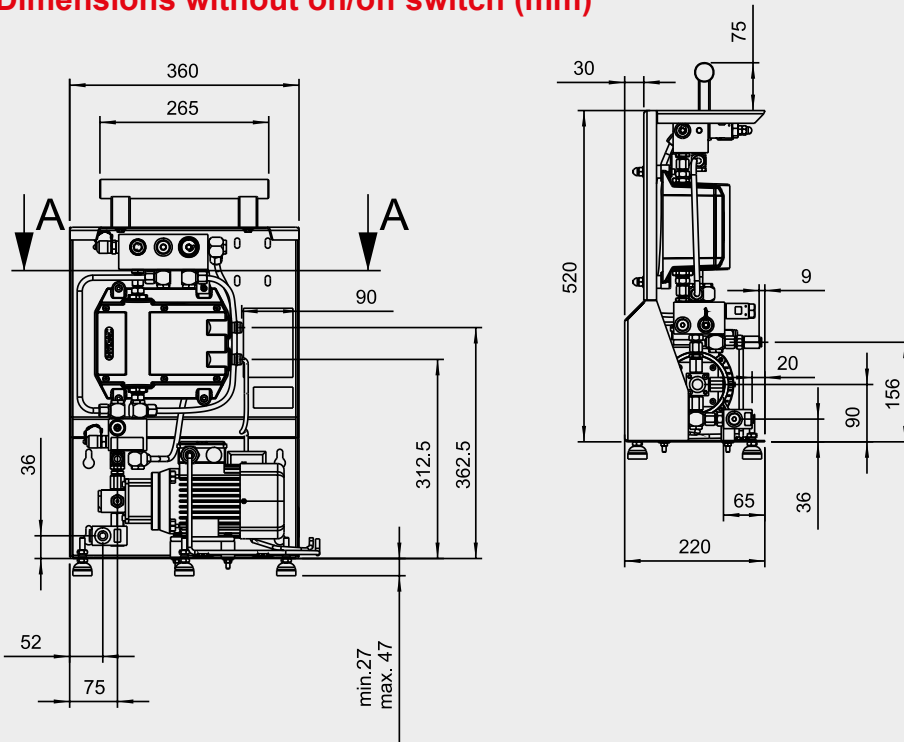

## Accessories

PC Software Package FluMoS Professional, Part no.: 3141522

PC Software Package FluMoS Light, Part no.: 3355176

PC Driver Package FluMoS, Part no.: 3355177

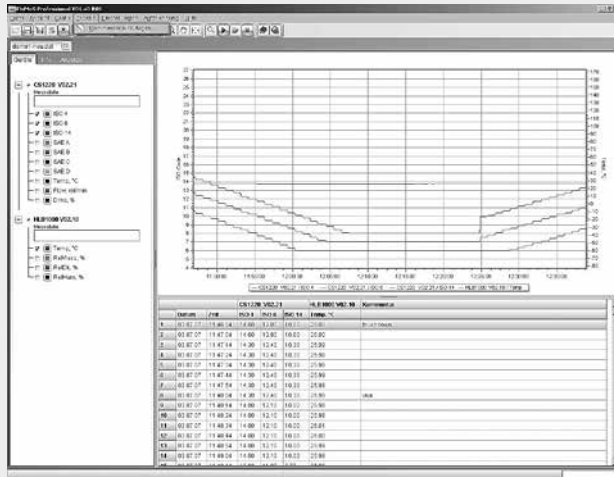

## ContaminationSensor Display CSD



ContaminationSensor Display

Display size

- 1 14 mm
- 2 57 mm

Supply voltage

U 24 VDC

CSD - 1 - U

	Part no.
CSD-1-U	3078272
CSD-2-U	3078273

## Accessories for AS 1000 option

- ZBE 08  
Female connector, right-angled, 5-pole, M12x1, Part No.: 6006786
- ZBE 08S-02  
Female connector, right-angled, 2 m cable, shielded, 5-pole, Part No.: 6019455
- ZBE 08S-05  
Female connector, right-angled, 5 m cable, shielded, 5-pole, M12x1, Part No.: 6019456
- ZBE 08S-10  
Female connector, right-angled, 10 m cable, shielded, 5-pole, M12x1, Part No.: 6023102

## Hole pattern

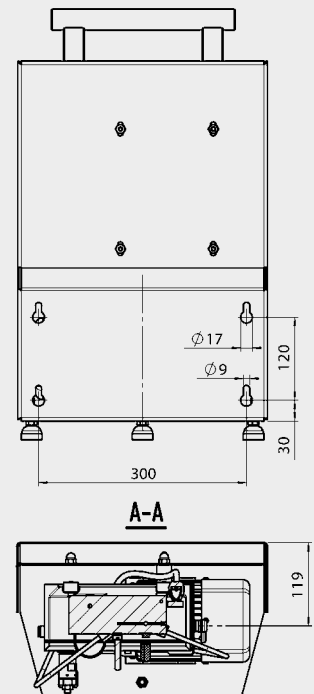

## Dimensions (mm)

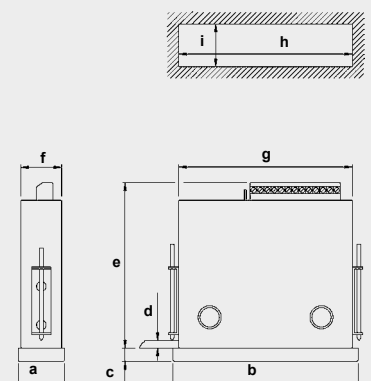

	a	b	c	d	e	f	g	h	i
CSD-1-U	48	96	8	.6	70	44	90	92	45
CSD-2-U	96	336	3	.6	61	88	328	329	89

**Note**

The information in this brochure relates to the operating conditions and applications described.

For applications and operating conditions not described, please contact the relevant technical department.

Subject to technical modifications.

**HYDAC FILTER SYSTEMS GMBH**

Justus-von-Liebig-Straße  
**D-66280 Sulzbach / Saar**  
Tel.: +49 (0) 6897/509-01  
Fax: +49 (0) 6897/509-9046  
Internet: [www.hydac.com](http://www.hydac.com)  
E-Mail: [filtersystems@hydac.com](mailto:filtersystems@hydac.com)