

Series EHD 61-151

4568 PSI

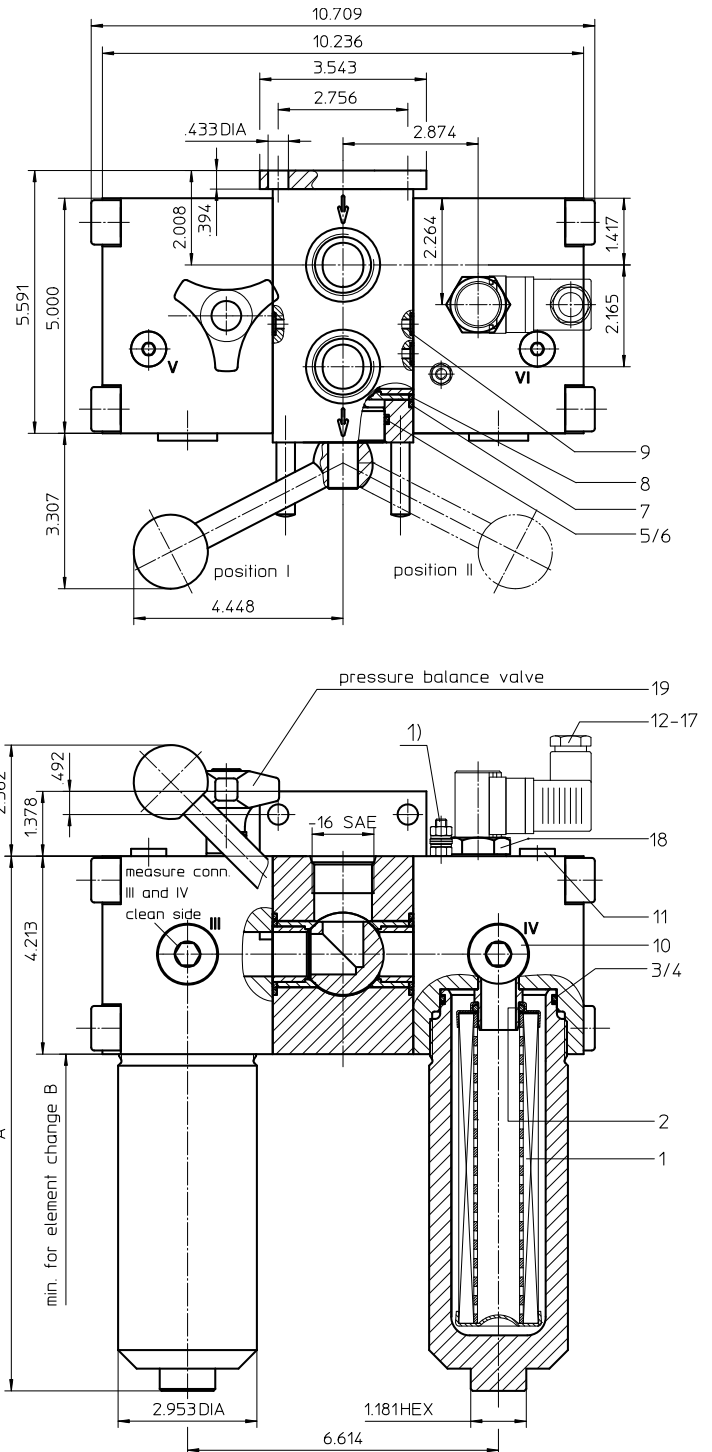

Position. I: left filter-side in operation
 Position. II: right filter-side in operation
 Connection V and VI used to
 bleed filter or to relieve pressure

Dimensions:

type	EHD 61	EHD 91	EHD 151
connection	- 16 SAE		
A	8.81	11.37	15.70
B	8.26	13.38	17.71
weight approx.	66 lbs.	70 lbs.	77 lbs.
volume tank	2x .06 Gal.	2x .10 Gal.	2x .16 Gal.

1) Connect the stand grounding tab to a suitable earth ground point.

Dimensions: inches

Designs and performance values are subject to change.



Powering Business Worldwide

Stainless Steel-Pressure Filter

Series EHD 61-151

4568 PSI

Description:

Stainless steel duplex filters series EHD have a working pressure up to 4568 PSI. Duplex filters can be serviced without interruption of operation.

The filter head has a three-way-change-over valve which diverts the flow from the dirty filter-side to the clean filter-side without interrupting operation of the filter. All filter housings have an integrated pressure balance valve to make main valve operation from one filter side to the other easier. Filter elements are available down to 5 $\mu\text{m}_{(c)}$. Finer filtration is available upon request.

Eaton filter elements are known for high intrinsic stability and an excellent filtration capability, a high dirt-retaining capacity and a long service life.

Eaton filter elements are suitable for all petroleum based fluids, HW-emulsions, most synthetic hydraulic fluids and lubrication oils.

Eaton filter elements are available up to a pressure resistance of Δp 2320 PSI and a rupture strength of Δp 3625 PSI.

The internal valve is integrated into the filter head. After reaching the bypass pressure setting, the bypass valve will send unfiltered partial flow around the filter.

The reversing valve provides another level of protection for the filter element. The reverse flow will not be filtered.

1. Type index:

1.1. Complete filter: (ordering example)

EHD. 91. 10VG. HR. E. P. VA. UG. 5. VA. -. AE											
1	2	3	4	5	6	7	8	9	10	11	12

1 series:

EHD = stainless steel-pressure filter, change over

2 nominal size: 61, 91, 151

3 filter-material and filter-fineness:

80G, 40G, 25G stainless steel wire mesh
25VG, 16VG, 10VG, 6VG, 3VG microglass

4 filter element collapse rating:

30 = Δp 435 PSI
HR = Δp 2320 PSI (rupture strength Δp 3625 PSI)

5 filter element design:

E = single-end open

6 sealing material:

P = Nitrile (NBR)
V = Viton (FPM)

7 filter element specification: (see catalog)

- = standard
VA = stainless steel

8 process connection:

UG = thread connection

9 process connection size:

5 = -16 SAE

10 filter housing specification:

VA = stainless steel

11 internal valve:

- = without
S1 = with by-pass valve Δp 51 PSI
S2 = with by-pass valve Δp 102 PSI
R = reversing valve, $Q \leq 18.50$ GPM

12 clogging indicator or clogging sensor:

- = without
AOR = visual, see sheet-no. 1606
AOC = visual, see sheet-no. 1606
AE = visual-electric, see sheet-no. 1615
VS5 = electronic, see sheet-no. 1619

To add an indicator to your filter, use the corresponding indicator data sheet to find the indicator details and add them to the filter assembly model code.

1.2. Filter element: (ordering example)

01E. 90. 10VG. HR. E. P. VA						
1	2	3	4	5	6	7

1 series:

01E. = filter element according to company standard

2 nominal size: 60, 90, 150

3 - 7 see type index-complete filter

Accessories:

- gauge port- and bleeder connection, see sheet-no. 1650

Technical data:

design temperature:	14 °F to +212 °F
operating temperature:	14 °F to +176 °F
operating medium	mineral oil, other media on request
max. operating pressure:	4568 PSI
test pressure:	6532 PSI
process connection:	thread connection
housing material:	EN 10088-3-1.4571 (316 Ti according to AISI)
sealing material:	Nitrile (NBR) or Viton (FPM), other materials on request
installation position:	vertical
air bleeding and measure connections dirt side:	BSPP ¼
measure connections clean side:	BSPP ¼

Classified under the Pressure Equipment Directive 2014/68/EC for mineral oil (fluid group 2), Article 4, Para. 3.
 Classified under ATEX Directive 2014/34/EC according to specific application (see questionnaire sheet-no. 34279-4).

Pressure drop flow curves:

Filter calculation/sizing

The pressure drop of the assembly at a given flow rate Q is the sum of the housing Δp and the element Δp and is calculated as follows:

$$\Delta p_{assembly} = \Delta p_{housing} + \Delta p_{element}$$

$$\Delta p_{housing} = (\text{see } \Delta p = f(Q) - \text{characteristics})$$

$$\Delta p_{element} (PSI) = Q (GPM) \times \frac{MSK}{1000} \left(\frac{PSI}{GPM} \right) \times \nu (SUS) \times \frac{\rho}{0.876} \left(\frac{kg}{dm^3} \right)$$

For ease of calculation our Filter Selection tool is available online at www.eatonpowersource.com/calculators/filtration/

Material gradient coefficients (MSK) for filter elements

The material gradient coefficients in PSI/GPM apply to mineral oil (HLP) with a density of 0.876 kg/dm³ and a kinematic viscosity of 139 SUS (30 mm²/s). The pressure drop changes proportionally to the change in kinematic viscosity and density.

EHD	VG					G		
	3VG	6VG	10VG	16VG	25VG	25G	40G	80G
61	6.748	4.685	2.999	2.577	1.760	0.2002	0.1868	0.1280
91	4.059	2.818	1.804	1.550	1.059	0.1210	0.1130	0.0774
151	2.422	1.681	1.076	0.925	0.632	0.0723	0.0675	0.0462

$\Delta p = f(Q)$ – characteristics according to ISO 3968

The pressure drop characteristics apply to mineral oil (HLP) with a density of 0.876 kg/dm³. The pressure drop changes proportionally to the density.

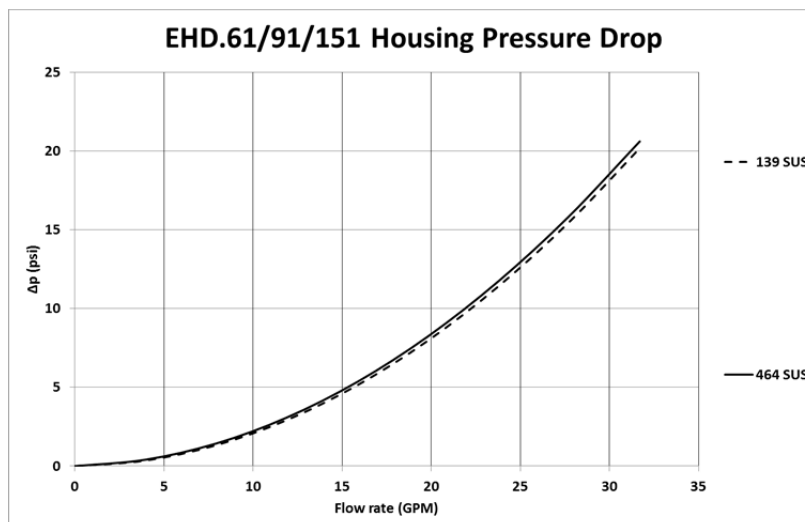

Symbols:

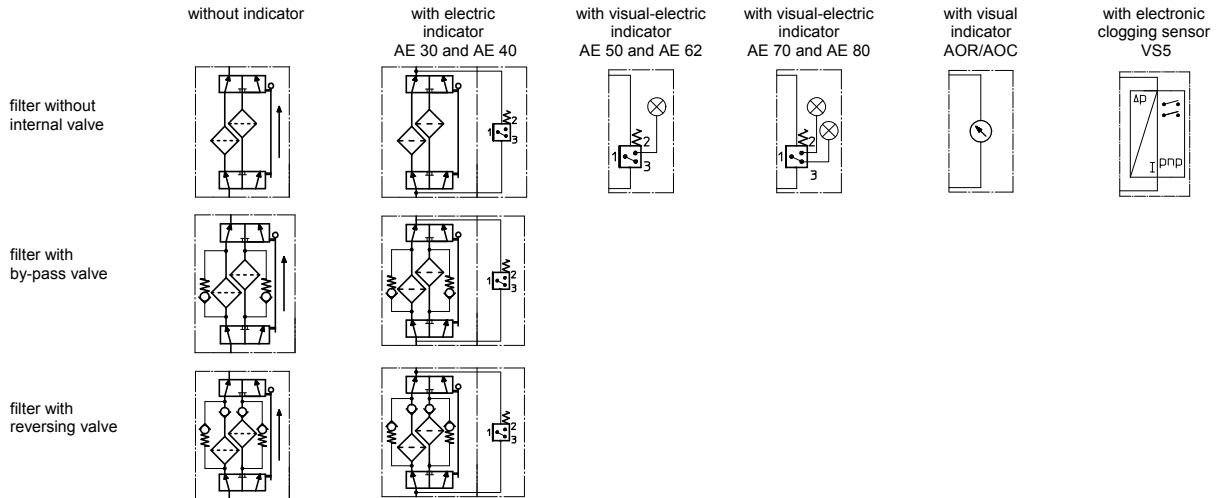

Spare parts:

item	qty.	designation	dimension			article-no.	
			EHD 61	EHD 91	EHD 151		
1	2	filter element	01E.60...	01E.90...	01E.150...		
2	2	O-ring		22 x 3,5		304341 (NBR)	304392 (FPM)
3	2	O-ring		56 x 3		305072 (NBR)	305322 (FPM)
4	2	support ring		63 x 2,6 x 1			312309
5	3	O-ring		45 x 3		304991 (NBR)	304997 (FPM)
6	2	support ring		49,7 x 2,4 x 1			317709
7	4	O-ring		38 x 3		304340 (NBR)	317013 (FPM)
8	4	O-ring		28 x 3		316778 (NBR)	318366 (FPM)
9	4	O-ring		8 x 2		310004 (NBR)	316530 (FPM)
10	2	screw plug		¼ BSPP			313815
11	2	screw plug		¼ BSPP			306968
12	1	clogging indicator, visual		AOR or AOC			see sheet-no. 1606
13	1	clogging indicator, visual-electric		AE			see sheet-no. 1615
14	1	clogging sensor, electronic		VS5			see sheet-no. 1619
15	1	O-ring		15 x 1,5		315357 (NBR)	315427 (FPM)
16	1	O-ring		22 x 2		304708 (NBR)	304721 (FPM)
17	1	O-ring		14 x 2		304342 (NBR)	304722 (FPM)
18	1	screw plug		20913-4			314442
19	1	pressure balance valve		3/8"			310316

item 18 execution only without clogging indicator or clogging sensor

Test methods:

Filter elements are tested according to the following ISO standards:

ISO 2941	Verification of collapse/burst resistance
ISO 2942	Verification of fabrication integrity
ISO 2943	Verification of material compatibility with fluids
ISO 3723	Method for end load test
ISO 3724	Verification of flow fatigue characteristics
ISO 3968	Evaluation of pressure drop versus flow characteristics
ISO 16889	Multi-pass method for evaluating filtration performance

North America

44 Apple Street
Tinton Falls, NJ 07724
Toll Free: 800 656-3344
(North America only)
Tel: +1 732 212-4700

Europe/Africa/Middle East

Auf der Heide 2
53947 Nettersheim, Germany
Tel: +49 2486 809-0

Friedensstraße 41
68804 Altlußheim, Germany
Tel: +49 6205 2094-0

An den Nahewiesen 24
55450 Langenlonsheim, Germany
Tel: +49 6704 204-0

China

No. 3, Lane 280,
Linhong Road
Changning District, 200335
Shanghai, P.R. China
Tel: +86 21 5200-0099

Singapore

4 Loyang Lane #04-01/02
Singapore 508914
Tel: +65 6825-1668

Brazil

Av. Julia Gaioli, 474 – Bonsucesso
07251-500 – Guarulhos, Brazil
Tel: +55 11 2465-8822

For more information, please
email us at filtration@eaton.com
or visit www.eaton.com/filtration

© 2015 Eaton. All rights reserved. All trademarks and registered trademarks are the property of their respective owners. All information and recommendations appearing in this brochure concerning the use of products described herein are based on tests believed to be reliable. However, it is the user's responsibility to determine the suitability for his own use of such products. Since the actual use by others is beyond our control, no guarantee, expressed or implied, is made by Eaton as to the effects of such use or the results to be obtained. Eaton assumes no liability arising out of the use by others of such products. Nor is the information herein to be construed as absolutely complete, since additional information may be necessary or desirable when particular or exceptional conditions or circumstances exist or because of applicable laws or government regulations.

Series EHD 241-451 4568 PSI

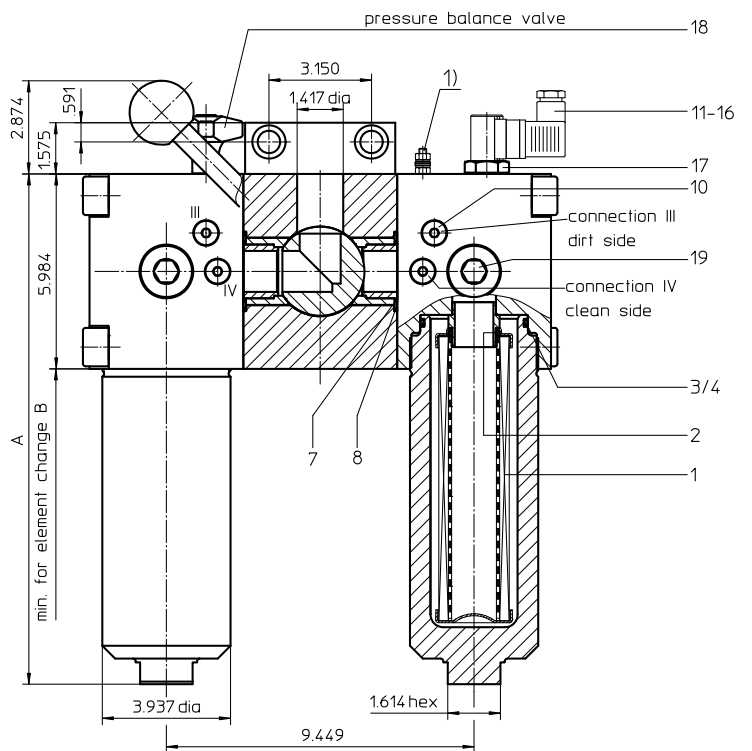
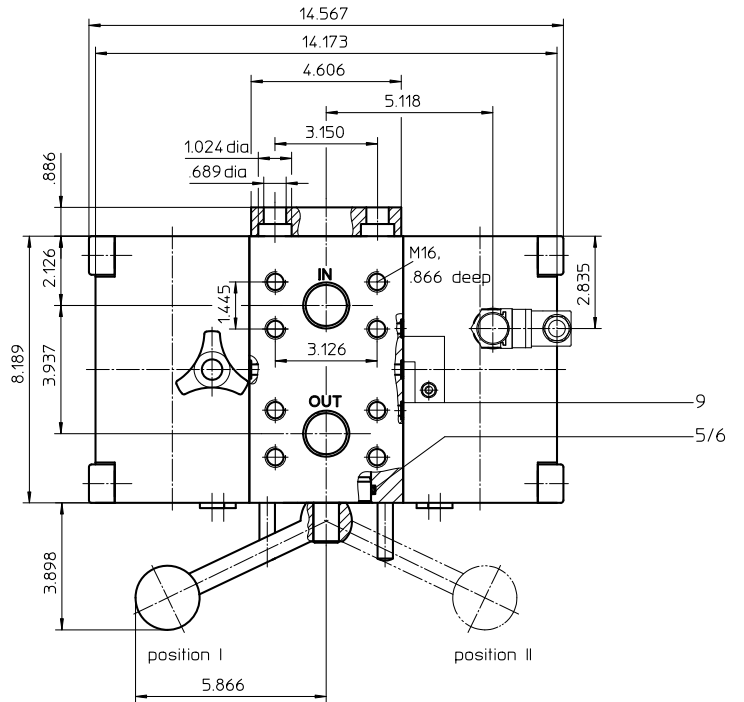

Position. I: left filter-side in operation
 Position. II: right filter-side in operation
 Connection III and IV used to
 bleed filter or to relieve pressure

Dimensions:

type	EHD 241	EHD 451
connection	SAE 1 1/2"	
A	15.67	22.95
B	13.88	30.67
weight approx.	224 lbs.	255 lbs.
volume tank	2x .22 Gal.	2x .40 Gal.

1) Connect the stand grounding tab to a suitable earth ground point.

Dimensions: inches

Designs and performance values are subject to change.



Powering Business Worldwide

Stainless Steel-Pressure Filter Series EHD 241-451 4568 PSI

Description:

Stainless steel duplex filters series EHD have a working pressure up to 4568 PSI. Duplex filters can be serviced without interruption of operation.

The filter head has a three-way-change-over valve which diverts the flow from the dirty filter-side to the clean filter-side without interrupting operation of the filter. All filter housings have an integrated pressure balance valve to make main valve operation from one filter side to the other easier. Filter elements are available down to 5 $\mu\text{m}_{(c)}$. Finer filtration is available upon request.

Eaton filter elements are known for high intrinsic stability and an excellent filtration capability, a high dirt-retaining capacity and a long service life.

Eaton filter elements are suitable for all petroleum based fluids, HW-emulsions, most synthetic hydraulic fluids and lubrication oils.

Eaton filter elements are available up to a pressure resistance of Δp 2320 PSI and a rupture strength of Δp 3625 PSI.

The internal valve is integrated into the filter head. After reaching the bypass pressure setting, the bypass valve will send unfiltered partial flow around the filter.

The reversing valve provides another level of protection for the filter element. The reverse flow will not be filtered.

1. Type index:

1.1. Complete filter: (ordering example)

EHD.	241.	10VG.	HR.	E.	P.	VA.	FS.	7.	VA.	-.	AE
1	2	3	4	5	6	7	8	9	10	11	12

1 | **series:**
EHD = stainless steel-pressure filter, change over

2 | **nominal size:** 241, 451

3 | **filter-material and filter-fineness:**
80G, 40G, 25G stainless steel wire mesh
25VG, 16VG, 10VG, 6VG, 3VG microglass

4 | **filter element collapse rating:**
30 = Δp 435 PSI
HR = Δp 2320 PSI (rupture strength Δp 3625 PSI)

5 | **filter element design:**
E = single-end open

6 | **sealing material:**
P = Nitrile (NBR)
V = Viton (FPM)

7 | **filter element specification:** (see catalog)
- = standard
VA = stainless steel

8 | **process connection:**
FS = SAE-flange 3000 PSI

9 | **process connection size:**
7 = 1 1/2"

10 | **filter housing specification:**
VA = stainless steel

11 | **internal valve:**
- = without
S1 = with by-pass valve Δp 51 PSI
S2 = with by-pass valve Δp 102 PSI
R = reversing valve, $Q \leq 55.75$ GPM

12 | **clogging indicator or clogging sensor:**
- = without
AOR = visual, see sheet-no. 1606
AOC = visual, see sheet-no. 1606
AE = visual-electric, see sheet-no. 1615
VS5 = electronic, see sheet-no. 1619

To add an indicator to your filter, use the corresponding indicator data sheet to find the indicator details and add them to the filter assembly model code.

1.2. Filter element: (ordering example)

01E.	240.	10VG.	HR.	E.	P.	VA
1	2	3	4	5	6	7

1 | **series:**
01E. = filter element according to company standard

2 | **nominal size:** 240, 450

3 | - 7 | see type index-complete filter

Accessories:

- gauge port- and bleeder connection, see sheet-no. 1650

Technical data:

design temperature:	14 °F to +212 °F
operating temperature:	14 °F to +176 °F
operating medium	mineral oil, other media on request
max. operating pressure:	4568 PSI
test pressure:	6532 PSI
process connection:	SAE-flange 3000 PSI
housing material:	EN 10088-3-1.4571 (316 Ti according to AISI)
sealing material:	Nitrile (NBR) or Viton (FPM), other materials on request
installation position:	vertical
air bleeding and measure connections:	BSPP ¼

Classified under the Pressure Equipment Directive 2014/68/EC for mineral oil (fluid group 2), Article 4, Para. 3.
 Classified under ATEX Directive 2014/34/EC according to specific application (see questionnaire sheet-no. 34279-4).

Pressure drop flow curves:

Filter calculation/sizing

The pressure drop of the assembly at a given flow rate Q is the sum of the housing Δp and the element Δp and is calculated as follows:

$$\Delta p_{assembly} = \Delta p_{housing} + \Delta p_{element}$$

$$\Delta p_{housing} = (\text{see } \Delta p = f(Q) \text{ - characteristics})$$

$$\Delta p_{element} (PSI) = Q (GPM) \times \frac{MSK}{1000} \left(\frac{PSI}{GPM} \right) \times \nu (SUS) \times \frac{\rho}{0.876} \left(\frac{kg}{dm^3} \right)$$

For ease of calculation our Filter Selection tool is available online at www.eatonpowersource.com/calculators/filtration/

Material gradient coefficients (MSK) for filter elements

The material gradient coefficients in PSI/GPM apply to mineral oil (HLP) with a density of 0.876 kg/dm³ and a kinematic viscosity of 139 SUS (30 mm²/s). The pressure drop changes proportionally to the change in kinematic viscosity and density.

EHD	VG					G		
	3VG	6VG	10VG	16VG	25VG	25G	40G	80G
241	2.092	1.452	0.930	0.799	0.546	0.0651	0.0607	0.0416
451	1.126	0.782	0.500	0.430	0.294	0.0349	0.0326	0.0223

$\Delta p = f(Q)$ – characteristics according to ISO 3968

The pressure drop characteristics apply to mineral oil (HLP) with a density of 0.876 kg/dm³. The pressure drop changes proportionally to the density.

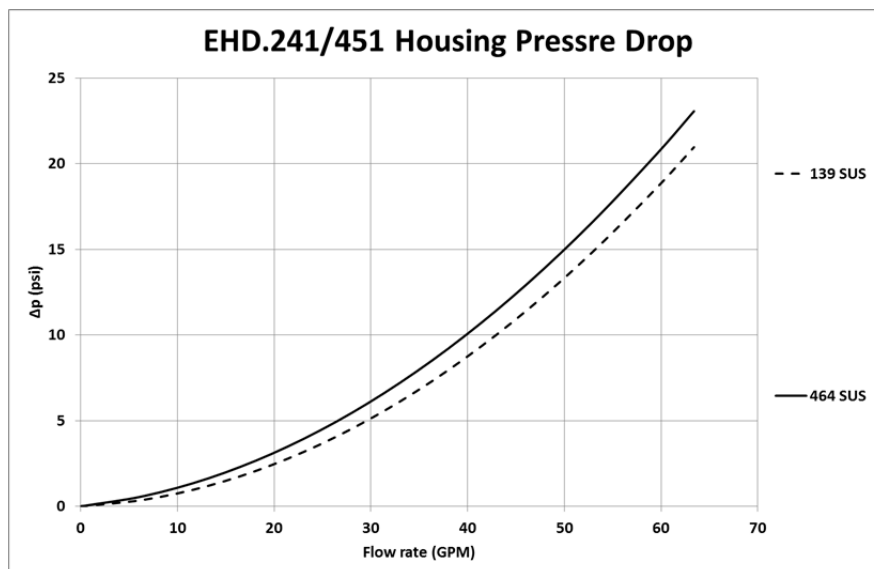

Symbols:

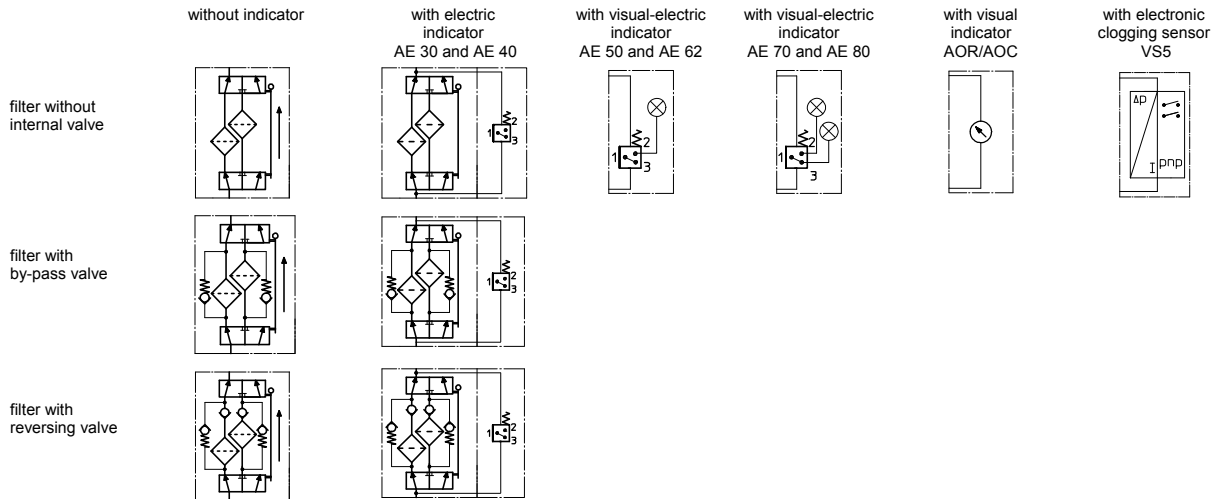

Spare parts:

item	qty.	designation	dimension		article-no.	
			EHD 241 01E.240...	EHD 451 01E.450...		
1	2	filter element				
2	2	O-ring		34 x 3,5	304338 (NBR)	304730 (FPM)
3	2	O-ring		76 x 4	305599 (NBR)	310291 (FPM)
4	2	support ring		84 x 3,2 x 1,5		312307
5	3	O-ring		70 x 4	306253 (NBR)	310280 (FPM)
6	2	sliding ring		076 x70 x 45°		318070
7	4	O-ring		56 x 3	305072 (NBR)	305322 (FPM)
8	4	O-ring		42,52 x 2,62	304352 (NBR)	304393 (FPM)
9	4	O-ring		10 x 2	309998 (NBR)	310272 (FPM)
10	4	screw plug		¼ BSPP		306968
11	1	clogging indicator visual		AOR or AOC		see sheet-no. 1606
12	1	clogging indicator visual-electric		AE		see sheet-no. 1615
13	1	clogging sensor electronic		VS5		see sheet-no. 1619
14	1	O-ring		15 x 1,5	315357 (NBR)	315427 (FPM)
15	1	O-ring		22 x 2	304708 (NBR)	304721 (FPM)
16	1	O-ring		14 x 2	304342 (NBR)	304722 (FPM)
17	1	screw plug		20913-4		314442
18	1	pressure balance valve		3/8"		310316
19	4	screw plug		1 BSPP		308498

item 17 execution only without clogging indicator or clogging sensor

Test methods:

Filter elements are tested according to the following ISO standards:

ISO 2941	Verification of collapse/burst resistance
ISO 2942	Verification of fabrication integrity
ISO 2943	Verification of material compatibility with fluids
ISO 3723	Method for end load test
ISO 3724	Verification of flow fatigue characteristics
ISO 3968	Evaluation of pressure drop versus flow characteristics
ISO 16889	Multi-pass method for evaluating filtration performance

North America

44 Apple Street
Tinton Falls, NJ 07724
Toll Free: 800 656-3344
(North America only)
Tel: +1 732 212-4700

Europe/Africa/Middle East

Auf der Heide 2
53947 Nettersheim, Germany
Tel: +49 2486 809-0

Friedensstraße 41
68804 Altlußheim, Germany
Tel: +49 6205 2094-0

An den Nahewiesen 24
55450 Langerlonsheim, Germany
Tel: +49 6704 204-0

China

No. 3, Lane 280,
Linhong Road
Changning District, 200335
Shanghai, P.R. China
Tel: +86 21 5200-0099

Singapore

4 Loyang Lane #04-01/02
Singapore 508914
Tel: +65 6825-1668

Brazil

Av. Julia Gaioli, 474 – Bonsucesso
07251-500 – Guarulhos, Brazil
Tel: +55 11 2465-8822

For more information, please

email us at filtration@eaton.com
or visit www.eaton.com/filtration

© 2015 Eaton. All rights reserved. All trademarks and registered trademarks are the property of their respective owners. All information and recommendations appearing in this brochure concerning the use of products described herein are based on tests believed to be reliable. However, it is the user's responsibility to determine the suitability for his own use of such products. Since the actual use by others is beyond our control, no guarantee, expressed or implied, is made by Eaton as to the effects of such use or the results to be obtained. Eaton assumes no liability arising out of the use by others of such products. Nor is the information herein to be construed as absolutely complete, since additional information may be necessary or desirable when particular or exceptional conditions or circumstances exist or because of applicable laws or government regulations.