

Damping Rails for Bell Housing Foot Bracket

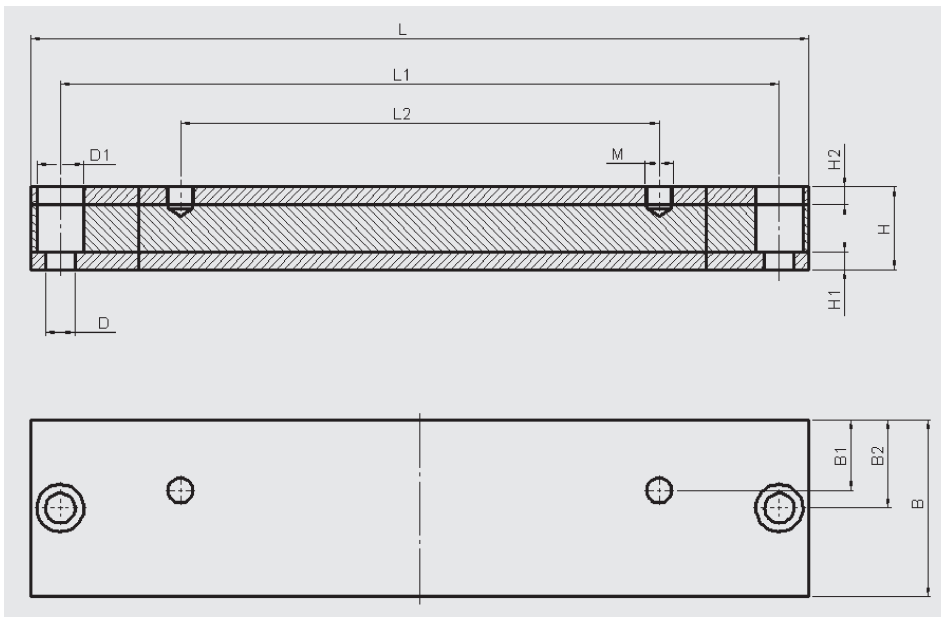

FEATURES

- Horizontal base mounting (not overhead mounted)
- Ready machined for bell housing base
- Noise reduction due to decoupling
- Resistant to mineral oil due to NBR rubber compound, shore A60 \pm 5
- Special lengths and models are possible on request



Damping rails *	For type	Part no.	L	L1	L2	H	H1	H2	B	B1	B2	D	D1	M
FDS 160/3	PF160/3	3156788	166	120	50	40	8	12	50	19	25	14	20	M8
FDS 200/3	PF200/3	721983	190	150	60	40	8	12	50	21	25	14	20	M10
FDS 250/3	PF250/3	721984	225	185	60	40	8	12	50	21	25	14	20	M12
FDS 300/3	PF300/3	721985	285	245	80	45	8	12	50	21	25	14	20	M12
FDS 350/3	PF350/3	721986	380	340	265	60	8	12	70	29	35	18	26	M16
FDS 300/4	PF300/4	3169191	350	300	225	40	8	12	50	25	20	14	20	M12
FDS 350/4	PF350/4	3169192	375	340	265	60	15	15	70	29	35	18	26	M16
FDS 400/4	PF400/4	3044302	420	385	300	60	15	15	70	30	35	18	26	M16
FDS 450/4	PF450/4	3044304	455	420	335	60	15	15	70	30	35	18	26	M16
FDS 550/4	PF550/4	3044305	535	500	415	60	15	15	70	30	35	18	26	M16
FDS 660/4	PF660/4	3044306	660	610	495	60	15	15	70	30	35	22	32	M20

*FDS .../3 for bell housing foot bracket for the light-duty range
FDS .../4 for bell housing foot bracket for heavy-duty range