

## APPLICATION

Subplates type G... nominal size 22 (NS22) with threaded connections, are designed to mount hydraulic elements with subplate connections nominal size 22 (NS22), with control ports and internal leakage drain ports or without them and the diameter of ports max  $\phi$  25.



## DESCRIPTION OF OPERATION

Subplates type G... nominal size 22 (NS22) with threaded connections are used to mount directional control valves, pressure valves, check valves with the configuration of holes on the mounting face in accordance with the connections:

- DIN 24340 form A (NG22)
- ISO 4401- 08-07-0-94 (ISO 4401 - 08)
- CETOP RP 121H - 4.2-4-08-320 (CETOP 08)

The range of hydraulic elements, nominal size 22 (NS22) produced by Ponar Wadowice that can be used for subplate mounting is included in the below table.

Hydraulic element	Type	Data sheet	Thickness of mounting (dimension in bolt length)
directional control valve, electro-hydraulically operated	WEH22	WK 460 110	41
directional control valve, hydraulically operated	WH22	WK 460 200	41
directional control valve, hand lever operated	WMM22	WK 460 330	41
double check valve, pilot operated	Z2S22	WK 450 229	100
double check/throttle valve, sandwich plate	Z2FS22	WK 450 237	58

# OVERALL AND CONNECTION DIMENSIONS

type **G151/01, G151/02**

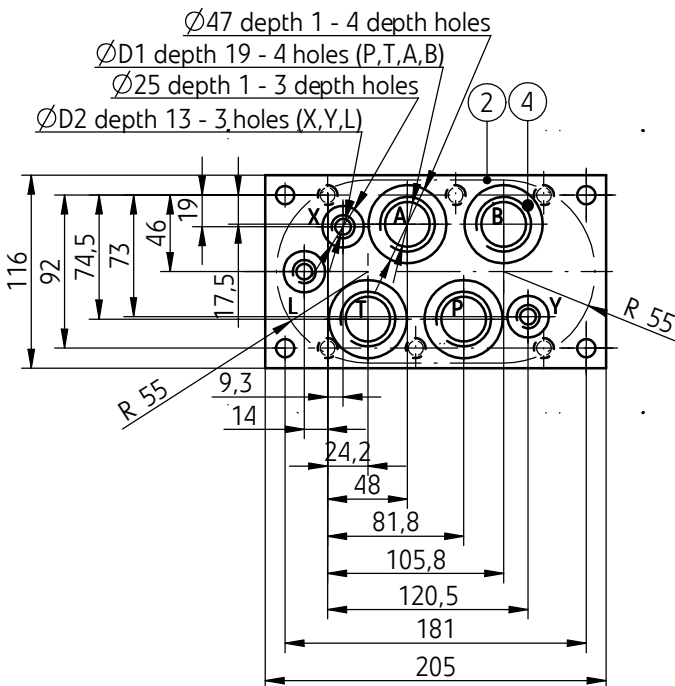
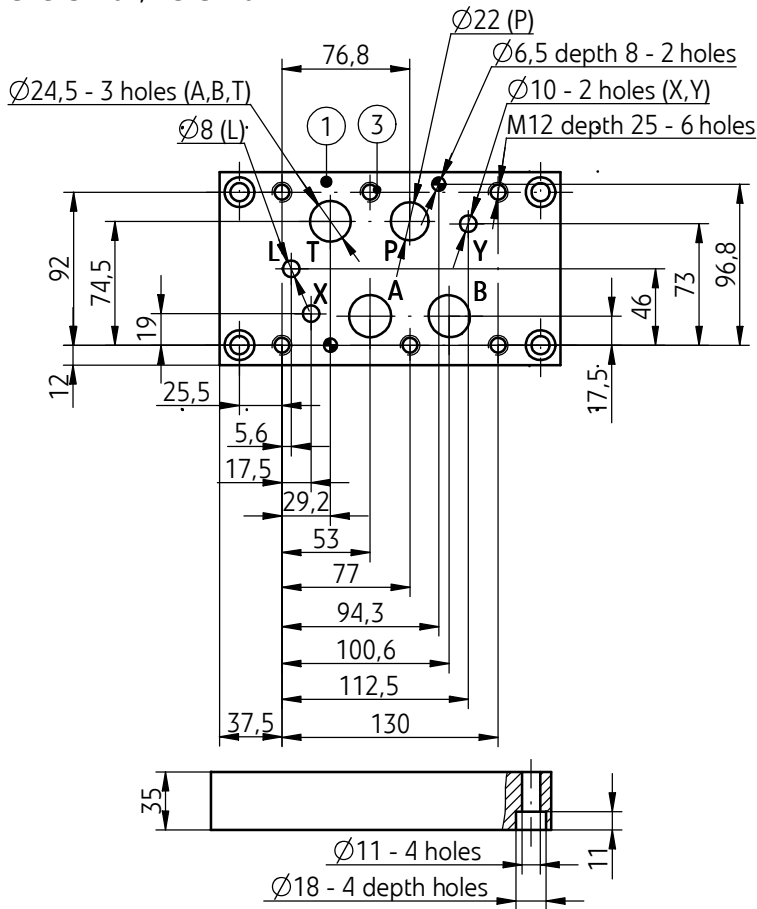

- 1 - Mounting face of hydraulic element (directional control valve, pressure valve, check valve)
- 2 - Recess in subplate for couplings of pipelines
- 3 - Holes of bolts mounting elements  
mounting bolts M12 x...-10.9 -6 pcs/kit, in accordance with PN - EN ISO 4762, tightening torque  $M_d = 105 \text{ Nm}$  must be ordered separately, bolts length is dependent on hydraulic elements type which can be sandwich mounted according to the table on page 1
- 4 - Connections for pipelines  
function of ports **P, T, A, B, X, Y, L:**
  - P** - pump connection
  - T** - oil return to the tank
  - A, B** - connections for a receiver
  - X** - control pressure supply - applied to:
    - directional control valve type **WH22**
    - directional control valve type **WEH22** with external fluid supply
  - Y** - oil return - applied to:
    - directional control valve type **WH22**
    - directional control valve type **WEH22** with external fluid return
    - directional control valve type **WMM22**
  - L** - leakage draining - applied to:
    - directional control valve type **WEH22** with hydraulic centering system

Subplate	$\phi$ D1	$\phi$ D2	Weight
<b>G 151/01</b>	G1	G1/4	5 kg
<b>G 151/02</b>	M33 x 2	M14 x 1,5	

# OVERALL AND CONNECTION DIMENSIONS

type **G154/01, G154/02, G156/01, G156/02**

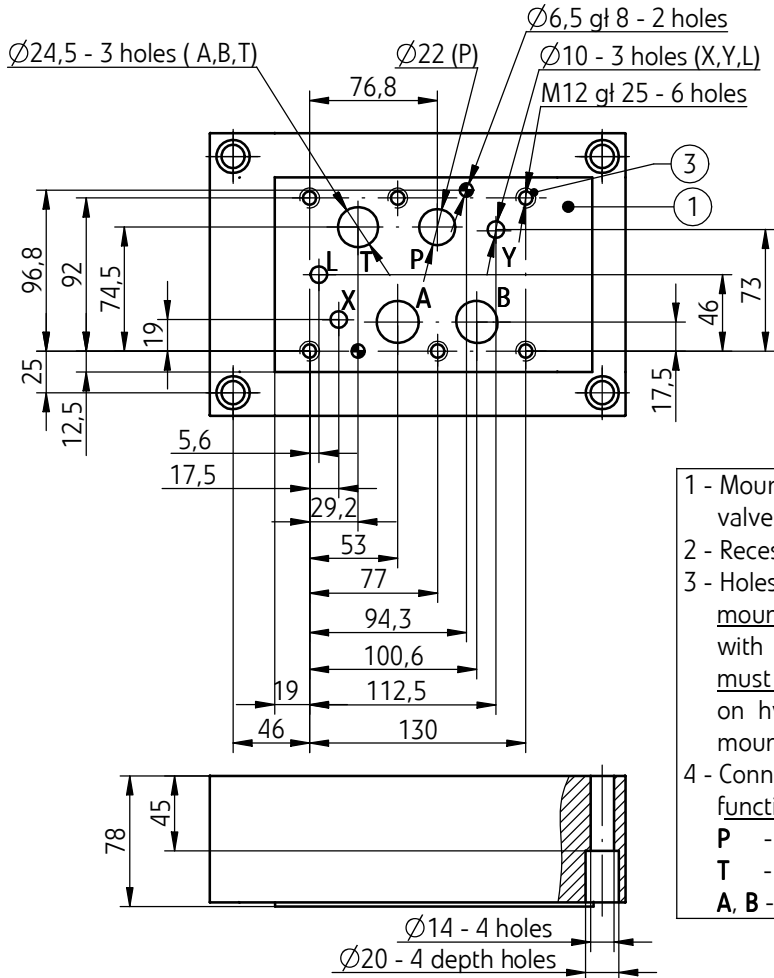

- 1 - Mounting face of hydraulic element (directional control valve, pressure valve, check valve)
- 2 - Recess in subplate for couplings of pipelines
- 3 - Holes of bolts mounting elements  
mounting bolts M12 x...-10.9 -6 pcs/kit, in accordance with **PN - EN ISO 4762**, tightening torque **Md = 105 Nm** must be ordered separately, bolts length is dependent on hydraulic elements type which can be sandwich mounted according to the table on page 1
- 4 - Connections for pipelines  
function of ports P, T, A, B, X, Y, L:  
**P** - pump connection  
**T** - oil return to the tank  
**A, B** - connections for a receiver

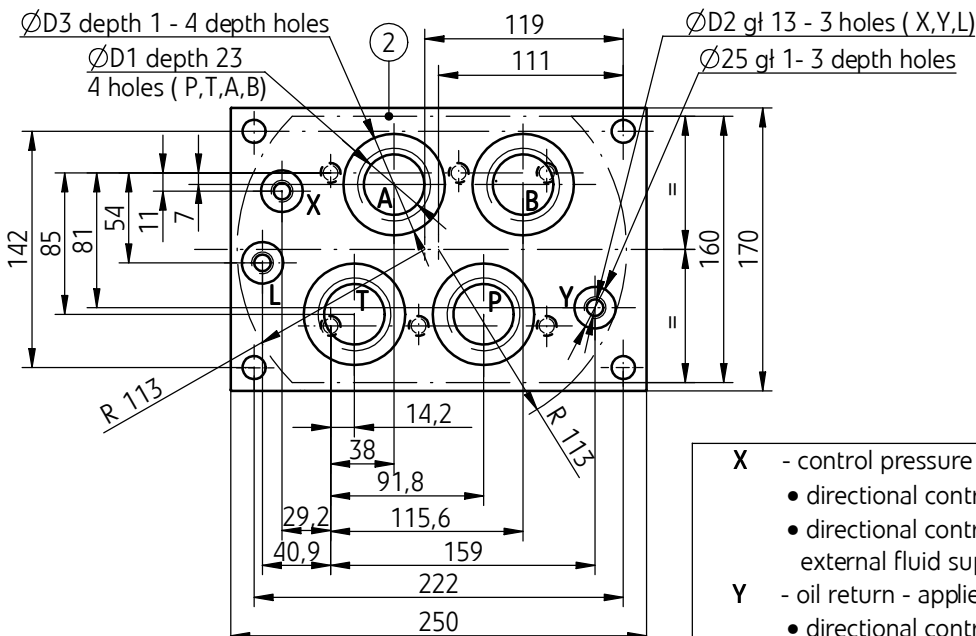

- X** - control pressure supply - applied to:
- directional control valve type **WH22**
  - directional control valve type **WEH22** with external fluid supply
- Y** - oil return - applied to:
- directional control valve type **WH22**
  - directional control valve type **WEH22** with external fluid return
  - directional control valve type **WMM22**
- L** - leakage draining - applied to:
- directional control valve type **WEH22** with hydraulic centering system

Subplate	φ D1	φ D2	φ D3	Weight
G 154/01	G1 1/4	G1/4	56	22 kg
G 154/02	M42 x 2	M14 x 1,5	56	
G 156/01	G1 1/2	G1/4	61	22 kg
G 156/02	M48 x 2	M14 x 1,5	61	

## HOW TO ORDER

Subplates type **G...** nominal size **22** should be ordered according to the type designation and including sizes of thread connections of pipelines (see page 2, 3).

Bolts mounting hydraulic elements **M10 x ...- 10.9** in accordance with **PN -EN ISO 4762** - 6 pcs/kit

(length dependent on type and number of elements sandwich mounted) should be ordered separately.

Coding example of subplate type **G...** nominal size **22** with thread connection **P, T, A, B - G1; X, Y, L - G 1/4:**  
Subplate type G 151/01

PONAR Wadowice S.A.  
ul. Wojska Polskiego 29  
34-100 Wadowice  
tel. +48 33 488 29 00  
fax. +48 33 488 21 03  
[www.ponar-wadowice.pl](http://www.ponar-wadowice.pl)

