



+ Flange



COUPLE SPLIT FLANGE
UN CUT SPLIT FLANGE

Flange



+ Flange

Specialist in Ball Valves

Carbon Steel

COUPLE SPLIT FLANGE

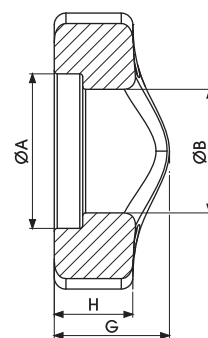
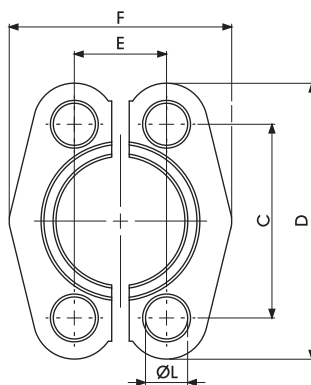

COUPLE SPLIT FLANGE S3000/CODE 61 WITHOUT SCREW

TYPE	MAX PRESSURE	A	B	C	D	E	F	G	H	I	L	METRIC	UNC	WEIGHT Kg	ITEM CODE
1/2"	21 MPa	30,96	24,26	38,10	54	17,48	45,6	19	13	6,22	8,5	M8 x 25	5/16 x 1 1/4	0,135	C0071802Z
3/4"	21 MPa	38,89	32,13	47,63	65	22,23	51,8	22	14	6,22	10,5	M10 x 30	3/8 x 1 1/4	0,175	C0071902Z
1"	21 MPa	45,24	38,48	52,37	70	26,19	58,4	24	16	7,49	10,5	M10 x 35	3/8 x 1 1/4	0,23	C0072002Z
1 1/4"	21 MPa	51,59	43,69	58,72	79	30,18	72,6	22	16	7,49	12	M10 x 35	7/16 x 1 1/2	0,30	C0072102Z
1 1/2"	21 MPa	61,09	50,80	69,85	94	35,71	82,2	25	16	7,49	13,5	M12 x 35	1/2 x 1 1/2	0,475	C0072202Z
2"	21 MPa	72,24	64,74	77,77	102	42,88	96,4	26	16	9,02	13,5	M12 x 35	1/2 x 1 1/2	0,535	C0076002Z
2 1/2"	17.5 MPa	84,94	74,93	88,90	114	50,80	108,2	38	19	9,02	13,5	M12 x 40	1/2 x 1 1/2	0,78	C0076302Z
3"	13.8 MPa	102,39	90,93	106,38	135	61,93	130,6	41	22	9,02	16,75	M16 x 50	5/8 x 2	1,27	C0076402Z

COUPLE SPLIT FLANGE S6000/CODE 62 WITHOUT SCREW

TYPE	MAX PRESSURE	A	B	C	D	E	F	G	H	I	L	METRIC	UNC	WEIGHT Kg	ITEM CODE
1/2"	42 MPa	32,54	24,64	40,49	56	18,24	47,2	22	16	7,24	8,5	M8 X 30	5/16 x 1 1/4	0,165	C0076502Z
3/4"	42 MPa	42,06	32,51	50,80	71	23,80	60	28	19	8,26	10,5	M10 X 35	3/8 x 1 1/2	0,325	C0076602Z
1"	42 MPa	48,41	38,86	57,15	81	27,76	69,9	33	24	9,02	13,5	M12 X 45	-	0,48	C0076702Z
1 1/4"	42 MPa	54,76	44,45	66,68	95	31,75	77,2	38	27	9,78	14,5	M12 X 50	1/2 x 1 3/4	0,73	C0076802Z
1 1/2"	42 MPa	64,29	51,56	79,38	113	36,50	95	43	30	12,07	16,75	M16 X 55	5/8 x 2	1,30	C0076902Z
2"	42 MPa	80,16	67,56	96,82	133	44,45	113,8	52	37	12,07	21	M20 X 65	3/4 x 2 1/2	1,95	C0077002Z
2 1/2"	42 MPa	108,90	90	123,80	180	58,80	150,2	45	45	20,50	26	M24 X 75	-	4,55	C0077102Z
3"	42 MPa	132,50	115	152,40	215	71,60	198,16	55	55	25,50	31	M30 X 90	-	8,25	C0077202Z

+ Flange

www.gemels.it

2017 - Edition 2

Carbon Steel

UN CUT SPLIT FLANGE

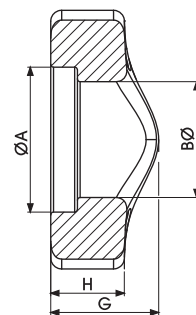
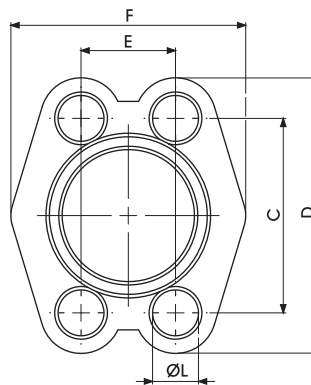

UNCUT SPLIT FLANGE S3000/CODE61 WITHOUT SCREW

TYPE	MAX PRESSURE	A	B	C	D	E	F	G	H	I	L	METRIC	UNC	WEIGHT Kg	ITEM CODE
1/2"	21 MPa	30,96	24,26	38,10	54	17,48	45,6	19	13	6,22	8,5	M8 X 25	5/16 X 1 1/4	0,135	C0077402Z
3/4"	21 MPa	38,89	32,13	47,63	65	22,23	51,8	22	14	6,22	10,5	M10 X 30	3/8 X 1 1/4	0,175	C0077502Z
1"	21 MPa	45,24	38,48	52,37	70	26,19	58,4	24	16	7,49	10,5	M10 X 35	3/8 X 1 1/4	0,23	C0077602Z
1 1/4"	21 MPa	51,59	43,69	58,72	79	30,18	72,6	22	16	7,49	12	M10 X 35	7/16 X 1 1/2	0,30	C0077702Z
1 1/2"	21 MPa	61,09	50,80	69,85	94	35,71	82,2	25	16	7,49	13,5	M12 X 35	1/2 X 1 1/2	0,475	C0077802Z
2"	21 MPa	72,24	64,74	77,77	102	42,88	96,4	26	16	9,02	13,5	M12 X 35	1/2 X 1 1/2	0,535	C0077902Z
2 1/2"	17.5 MPa	84,94	74,93	88,90	114	50,80	108,2	38	19	9,02	13,5	M12 X 40	1/2 X 1 1/2	0,78	C0078002Z
3"	13.8 MPa	102,39	90,93	106,38	135	61,93	130,6	41	22	9,02	16,75	M16 X 50	5/8 X 2	1,27	C0078102Z

UNCUT SPLIT FLANGE S6000/CODE62 WITHOUT SCREW

TYPE	MAX PRESSURE	A	B	C	D	E	F	G	H	I	L	METRIC	UNC	WEIGHT Kg	ITEM CODE
1/2"	42 MPa	32,54	24,64	40,49	56	18,24	47,2	22	16	7,24	8,5	M8 X 30	5/16 X 1 1/4	0,165	C0078202Z
3/4"	42 MPa	42,06	32,51	50,80	71	23,80	60	28	19	8,26	10,5	M10 X 35	3/8 X 1 1/2	0,325	C0078302Z
1"	42 MPa	48,41	38,86	57,15	81	27,76	69,9	33	24	9,02	13,5	M12 X 45	-	0,48	C0078402Z
1 1/4"	42 MPa	54,76	44,45	66,68	95	31,75	77,2	38	27	9,78	14,5	M12 X 50	1/2 X 1 3/4	0,73	C0078502Z
1 1/2"	42 MPa	64,29	51,56	79,38	113	36,50	95	43	30	12,07	16,75	M16 X 55	5/8 X 2	1,30	C0078602Z
2"	42 MPa	80,16	67,56	96,82	133	44,45	113,8	52	37	12,07	21	M20 X 65	3/4 X 2 1/2	1,95	C0078702Z
2 1/2"	42 MPa	108,90	90	123,80	180	58,80	150,2	45	45	20,50	26	M24 X 75	-	4,55	C0078802Z
3"	42 MPa	132,50	115	152,40	215	71,60	198,16	55	55	25,50	31	M30 X 90	-	8,25	C0078902Z

Flange

