



HYDRAULIC COMPONENTS
HYDROSTATIC TRANSMISSIONS
GEARBOXES - ACCESSORIES

Certified Company ISO 9001 - 14001



Via M. L. King, 6 - 41122 MODENA (ITALY)

Tel: +39 059 415 711

Fax: +39 059 415 729 / 059 415 730

INTERNET: <http://www.hansatmp.it>

E-MAIL: hansatmp@hansatmp.it

HT 16 / M / 118 / 0416 / E

THE PRODUCTION LINE OF HANSA-TMP

Variable Displacement Closed Loop System Axial Piston Pump

TPV 1000

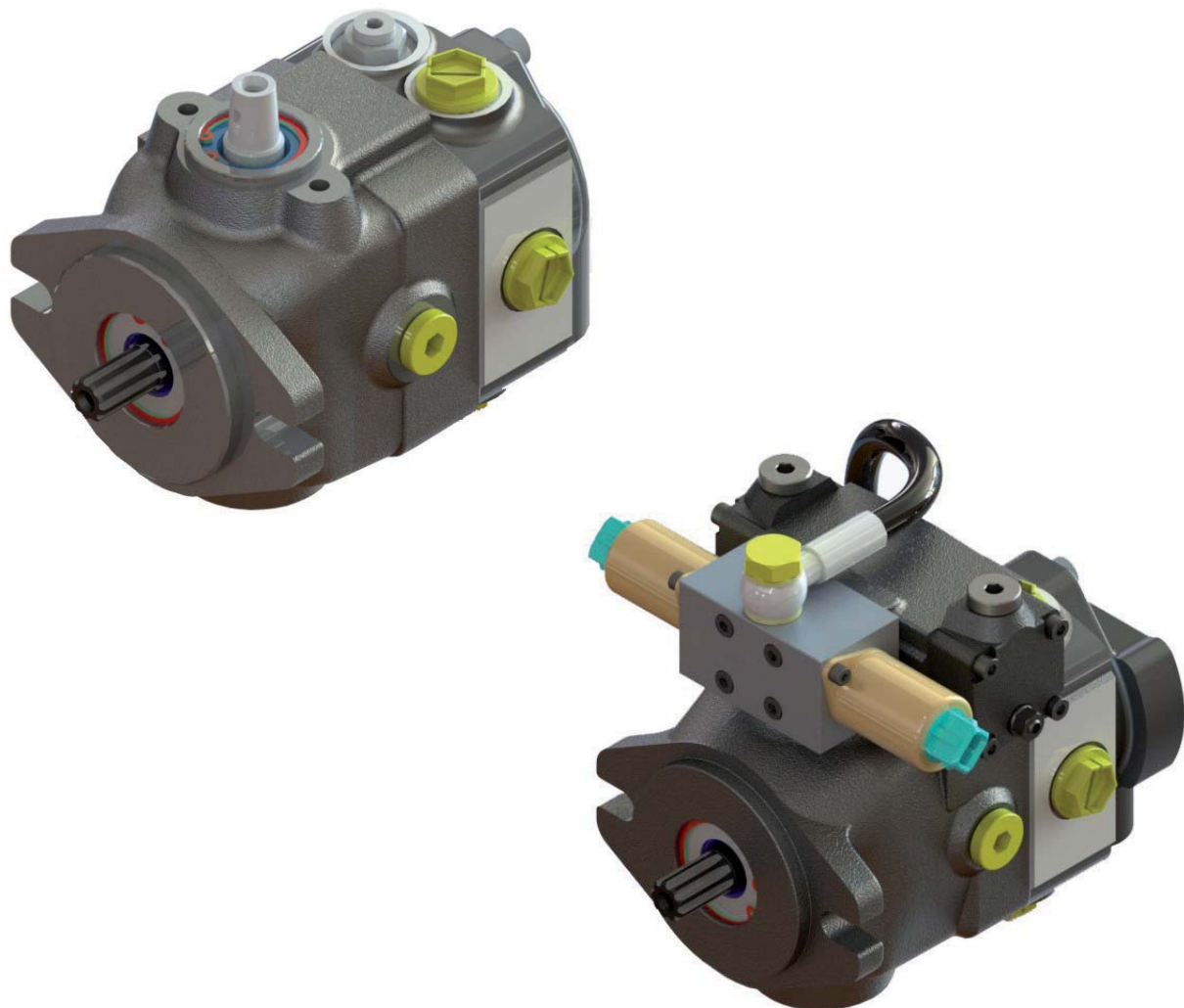

INDEX

General Information.....	4
Technical Specifications.....	5
Performance Diagram.....	6
General Instructions.....	7
TPV 1000	
Order Code.....	8 - 10
Single Pump - Direct Mechanical Control.....	11
Single Pump - Hydraulic Servo Control.....	12
Tandem Pump - Installation Drawing.....	13
Triple Pump - Installation Drawing.....	14
Shafts.....	16 - 17
Mounting Flanges.....	18
DM Direct Mechanical Control without Lever.....	19
BC Tapered Bush.....	20
LC Direct Mechanical Control with Lever.....	21
DMS Control Lever with Return to Zero Position (torsion spring).....	22 - 23
DMZ Control Lever with Return to Zero Position (compression spring).....	24 - 25
SHI Hydraulic Servo Control.....	26 - 27
SEI 1.3 - 2.3 Electro-Proportional Servo Control.....	28 - 30
Control Device Position - Primary and Secondary Pump.....	31
Rear Pump Mounting Flanges C Standard Version - B1 Compact Version.....	32
Rear Pump Mounting Flanges B1 - B2.....	33
Rear Pump Mounting Flanges B2 Compact Version - SA-R.....	34
OPTIONAL LB Lever By-pass.....	35
OPTIONAL VS Purge Valve.....	36
OPTIONAL VSLB Purge Valve + Lever By-pass.....	37
OPTIONAL SB Screw By-pass.....	38
OPTIONAL FB SAE-A - SAE-B Mounting Flange.....	39
OPTIONAL ST Coupling Z = 9 / Z = 13.....	39
OPTIONAL FBST Mounting Flange + Coupling.....	40
Accessories.....	41

GENERAL INFORMATION

Features

- Silent running
- High rotation speed
- Compact design
- Suitable for multiple pump assembly
- Easy maintenance
- Built-in pressure relief valves
- Optionals: screw or lever-type by-pass-valve, purge valve, adapter flange from SAE-A to SAE-B

- Accessories: auxiliary gearpumps, hydraulic and electric remote controls, mounting kit for diesel and petrol engines

All HANSA-TMP's TPV pumps are tested dynamically and statically to ensure the quality of our product.

TPV pumps are variable displacement axial piston pumps, with swashplate system, for closed loop hydrostatic transmissions

Direct Mechanical Control

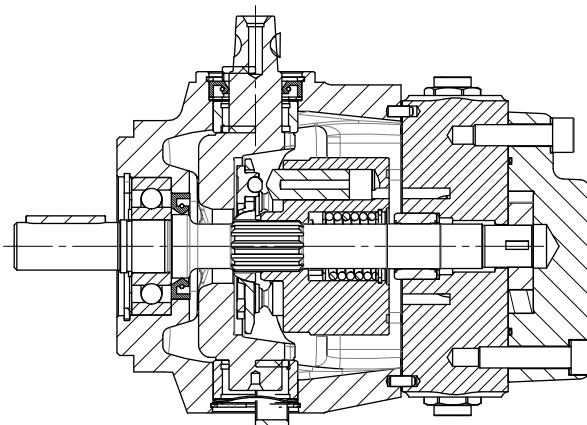

Hydraulic Servo Control

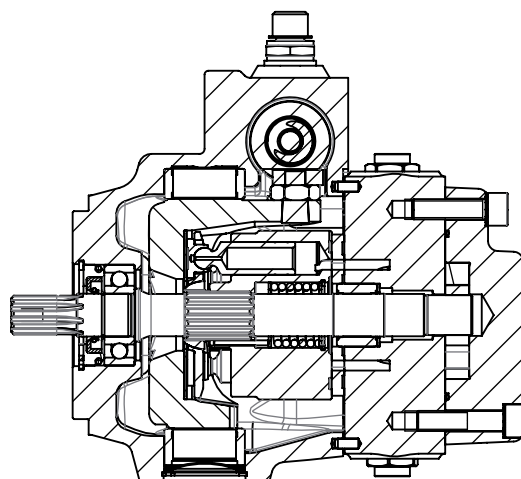

TECHNICAL SPECIFICATIONS

PUMP MODEL		TPV 6-7	TPV 8-7	TPV 9-7	TPV 11-7	TPV 12-7	TPV 13-7	TPV 15-9	TPV 17-9	TPV 18-9	TPV 19-9	TPV 21-9
Max. displacement	cm ³	7,4	8,9	9,6	11,2	12,8	13,6	15,00	17,1	18,2	19,4	21,15
Flow rating ⁽¹⁾	L/min	25,01	31,96	34,74	40,32	46,08	48,88	54,00	61,77	66,37	69,84	76,4
Power rating ⁽¹⁾	kW	8,75	11,18	12,15	14,11	16,12	17,11	18,9	21,61	23,23	24,44	31,73
Boost pump displacement	cm ³ /n	3,9 (rear cover closed B1, B2) 4,7 (rear cover SAE-A)										
Rated pressure	MPa	21										20
Max. pressure	MPa	30	30	30	30	30	30	28	28	27	25	
Max. relief valve setting	MPa	30										
Standard boost pressure ⁽²⁾	MPa	0,6 (mechanical control) 2 (hydraulic / electric servo control)										
Suction pressure	MPa (absolute)	> = 0,08										
Max. case pressure	MPa	0,15										
Min. shaft speed	n/min	500										
Rated speed	n/min	3.600										2900
Max. speed	n/min	3.900										3200
Max. oil temperature	°C	80										
Oil viscosity	cSt	15-35										
Fluid contamination		18/15/12 ISO 4406 (NAS 9)										
Dry weight (single pump) ⁽³⁾	kg	9										
Dry weight (tandem pump) ⁽³⁾	kg	19,5										

(1) 3.600 n/min 21 MPa

(2) 1.000 n/min

(3) Nominal data, weight varies depending on configuration and optional

PERFORMANCE DIAGRAM

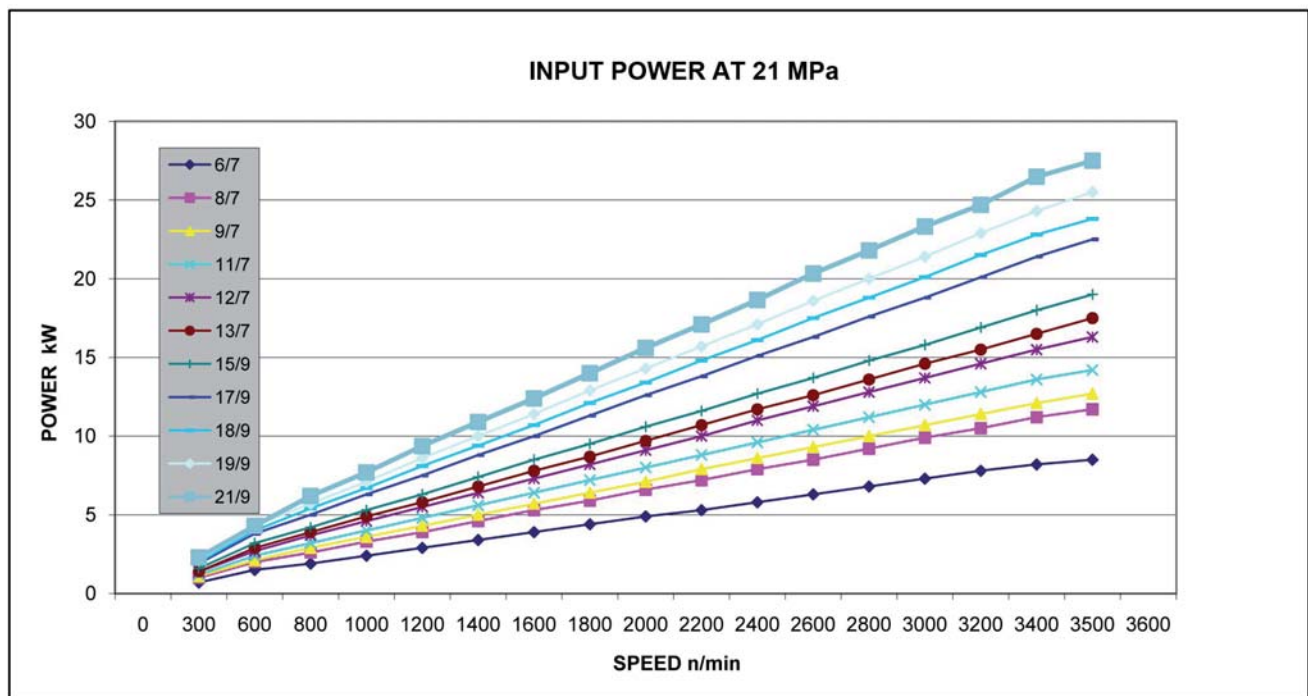
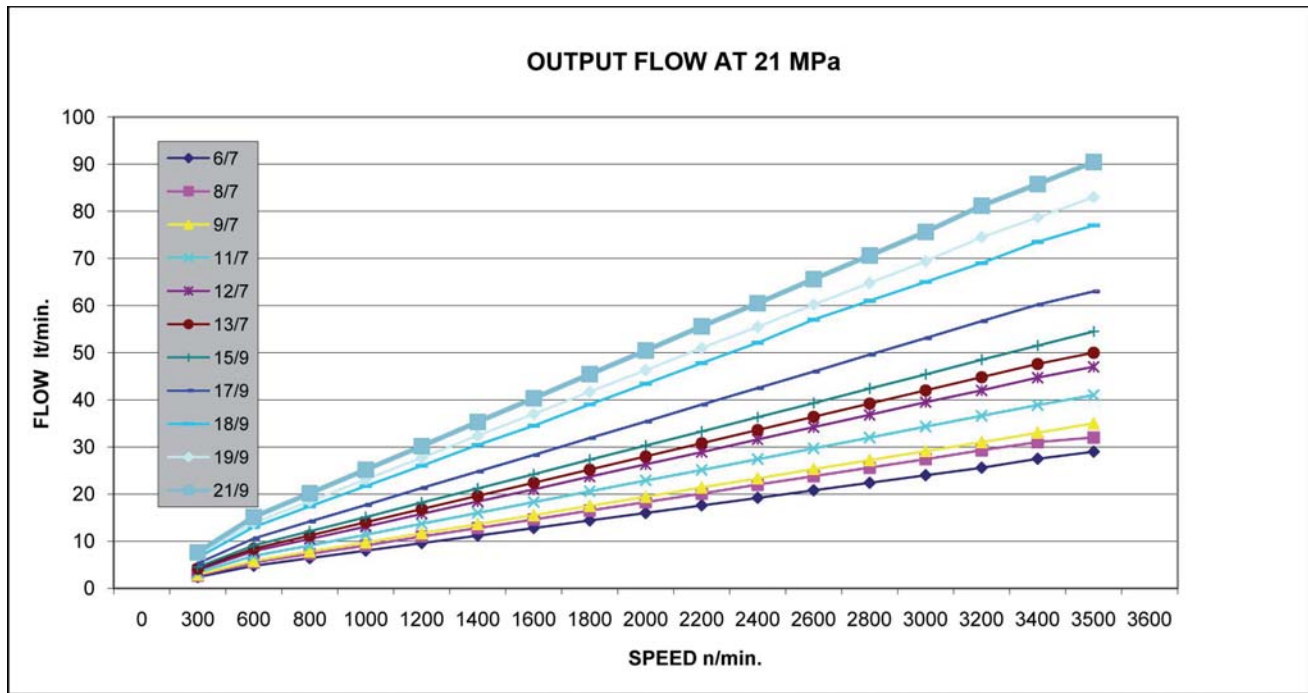

GENERAL INSTRUCTIONS

- During the assembly, check that pump is in line and concentric with the driveshaft sleeve to prevent overloading of the pump shaft bearing.
- Clean carefully all tanks and pipes internally before assembly.
- The pipe internal diameter must be suitable for the max oil speed through it.
- It is advisable to fit the pump below the oil level of tank.
- Heat exchangers must be considered in the machine design, to keep temperature level within the limit of 80°C.

Multiple Pumps

- In case of installing a multiple pump it is advisable to mount a supplementary support.

Maximum Shaft Torque

In the case of installation of multiple pump, verify that the total shaft torque is not more than the maximum value rated for each type of shaft.

Optional

The TPV pumps can be supplied in different versions, with different types of shaft and equipped with different types of control devices and optionals:

- Direct mechanical control lever DM
- Spring zero return DMS
- Hydraulic servo-control SHI
- Electric proportional servo-control SEI
- By-pass lever LB
- Screw By-pass SB

- Purge valve VS
- Adaptor flange from SAE-A to SAE-B FB
- Adaptor coupling Z = 9 / Z = 13 ST
- Purge valve + By-pass lever VSLB

First Starting

- Before starting fill all the system components with new and filtered oil.
- Verify that the boost pressure is correct.
- Restore the tank oil level.

Maintenance

- The first oil change must be made after approximately 500 hours of operation. In the following every 2000 hours.
- The filter cartridge must be replaced for the first time after 50 hours. In the following 500 hours; such time should be reduced if the filter clogging indicator shows that the cartridge is clogged or when the system works in a heavily polluted environment.

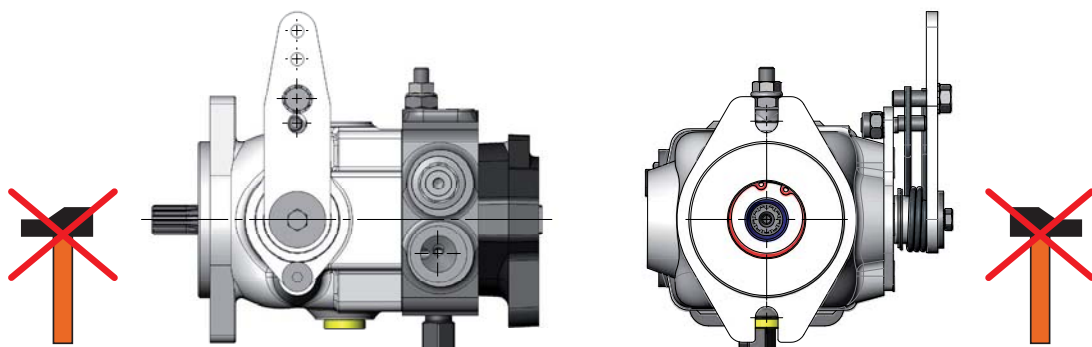

ORDER CODE _____

1000	TPV	6-7	-	CR	SS2	F1	DM	OA	-	10	06	B1	000	00
0	1	2	3	4	5	6	7	8	9	10	11	12	13	14

Pag.

1000	0 - Pump series = TPV pump 1000	
	1 - Pump model	
TPV	= Closed loop circuit single pump	11
TPV-T	= Closed loop circuit tandem pump	13
TPV-T3	= Closed loop circuit triple pump	14
TPVS*	= Closed loop circuit special pump according to customer request	
	2 - Pump displacement (single or primary)	
	6-7 = 7,4 cm ³ /n 8-7 = 8,9 cm ³ /n 9-7 = 9,6 cm ³ /n 11-7 = 11,2 cm ³ /n	
	12-7 = 12,8 cm ³ /n 13-7 = 13,6 cm ³ /n 15-9 = 15 cm ³ /n 17-9 = 17,1 cm ³ /n	
	18-9 = 18,2 cm ³ /n 19-9 = 19,4 cm ³ /n 21-9 = 21,15 cm ³ /n	
	3 - Pump displacement (tandem or secondary)	
	6-7 = 7,4 cm ³ /n 8-7 = 8,9 cm ³ /n 9-7 = 9,6 cm ³ /n 11-7 = 11,2 cm ³ /n	
	12-7 = 12,8 cm ³ /n 13-7 = 13,6 cm ³ /n 15-9 = 15 cm ³ /n 17-9 = 17,1 cm ³ /n	
	18-9 = 18,2 cm ³ /n 19-9 = 19,4 cm ³ /n 21-9 = 21,15 cm ³ /n	
	4 - Rotation	
CR	= Clockwise Rotation (right)	
CC	= Counter-clockwise Rotation (left)	
	5 - Drive Shaft	
SS2	= Splined shaft Z 9 - 16 / 32 D.P.	16
PS1	= Parallel keyed shaft 15,875 mm. diam. (available only for single pump)	16
PS3	= Parallel keyed shaft 18 mm. diam. with heavy duty bearing for external radial load	17
SS3	= Splined shaft Z 13 - 16 / 32 D.P. (available only with servo-control SHI, SEI and SAE-B flange)	17
	6 - Mounting flange	
F1	= SAE-A 2 bolt - spigot diam. 82,5 mm.	18
F2.1	= SAE-B 2 bolt - spigot diam. 101,6 mm. (available only with servo-control SHI, SEI and shaft SS3)	18
	7 - Controls	
DM	= Direct mechanical (without control lever)	19
BC	= Tapered bush	20
LC	= Control lever	21
DMS	= Control lever with return to zero position (torsion spring standard diameter 3,6 mm.)	22
DMS (30)	= Control lever with return to zero position (torsion spring diameter 3 mm.)	22
DMS (33)	= Control lever with return to zero position (torsion spring diameter 3,3 mm.)	22
DMS (40)	= Control lever with return to zero position (torsion spring diameter 4 mm.)	22
DMS (50)	= Control lever with return to zero position (torsion spring diameter 5 mm.)	22
DMZB	= Control lever with return to zero position (blue compression spring standard)	24
DMZR	= Control lever with return to zero position (red compression spring)	24
DMZV	= Control lever with return to zero position (green compression spring)	24
SHI	= Hydraulic proportional servo-control	26
SEI 1.3	= Electro-proportional servo-control 12V DC	28
SEI 2.3	= Electro-proportional servo-control 24V DC	28

(continued)

ORDER CODE _____

	8 - Control devices position (single or primary pump)	
OA	= Position A (without lever)	31
OB	= Position B (without lever)	
LA	= Position A-left	
RA	= Position A-right	
LB	= Position B-left	
RB	= Position B-right	

	9 - Control devices position (tandem or secondary pump)	
OA	= Position A (without lever)	31
OB	= Position B (without lever)	
LA	= Position A-left	
RA	= Position A-right	
LB	= Position B-left	
RB	= Position B-right	

	10 - Relief valve pressure setting *			
	10 = 10 MPa	15 = 15 MPa	18 = 18 MPa	
	20 = 20 MPa	25 = 25 MPa	30 = 30 MPa	

* The rated pressure values change according to speed

	11 - Boost pump	
00	= Without boost pump	
01	= Without boost pump compact version (only for rear pump flange B1 - B2)	
06	= Standard pump C-B1-B2 (3,9 cm ³ /n); SAE-A (4,7 cm ³ /n) Standard setting: 0,6 MPa (mechanical control) or 2 MPa (hydraulic / electric servo control) at 1000 n/min.	
06(xx)	= Other pressure settings on request (between 0,8 and 3 MPa), contact our technical department	

	12 - Rear pump connection option	
C	= Closed cover (without rear fitting)	32
B1	= For German standard pump group 1 mounting	32
B2	= For German standard pump group 2 mounting	33
SA-R	= For SAE-A 2 bolt mounting flange (female shaft)	34

	13 - Gear pump displacement **	
000	= Without pump	

Group 1			
112 = 1,2 cm ³ /n	117 = 1,7 cm ³ /n	122 = 2,1 cm ³ /n	126 = 2,6 cm ³ /n
132 = 3,1 cm ³ /n	138 = 3,6 cm ³ /n	143 = 4,2 cm ³ /n	149 = 4,9 cm ³ /n
159 = 5,9 cm ³ /n	165 = 6,5 cm ³ /n	178 = 7,5 cm ³ /n	

Group 2			
204 = 4,2 cm ³ /n	206 = 6,0 cm ³ /n	209 = 8,4 cm ³ /n	211 = 10,8 cm ³ /n
214 = 14,4 cm ³ /n	217 = 16,8 cm ³ /n	219 = 19,2 cm ³ /n	222 = 22,8 cm ³ /n
226 = 26,2 cm ³ /n			

** Also available multiple gear pumps (for instance: 204+117)

(continued)

ORDER CODE _____

	14 - Optional	
	00 = Without optional	
	LB = Lever by-pass	35
	VS = Purge valve	36
	VSLB = Lever by-pass + Purge Valve	37
	SB = Screw by-pass	38
	FB = Conversion flange from SAE-A to SAE-B	39
	ST = Conversion shaft 9 teeth to 13 teeth	39
	FBST = Conversion flange from SAE-A to SAE-B + Conversion shaft 9 teeth to 13 teeth	40
	PR = Full resistant swash plate bearing	40
	G/J/M/- = Port threads and restrictor diameter (see table below)	

*** Please contact our technical department to know the available configurations

	Servo control type	Port threads	Symbol
STANDARD	SEI	Plugged	-
	SHI	1/4" BSPP	G
ON REQUEST	SHI	JIC (7/16" - 20)	J
	SHI	METRIC (M12x1,5)	M

Example G/08 = 1/4" BSPP port threads and Ø 0,8 mm restrictor (SHI)

Example -/08 = Ø 0,8 mm restrictor (SEI)

Restrictor diameter (SHI/SEI)	
-	Without restrictor
06	Restrictor orifice Ø 0,6 mm
08	Restrictor orifice Ø 0,8 mm
10	Restrictor orifice Ø 1,0 mm
12	Restrictor orifice Ø 1,2 mm
16	Restrictor orifice Ø 1,6 mm
20	Restrictor orifice Ø 2,0 mm

SINGLE PUMP

(Direct mechanical control)

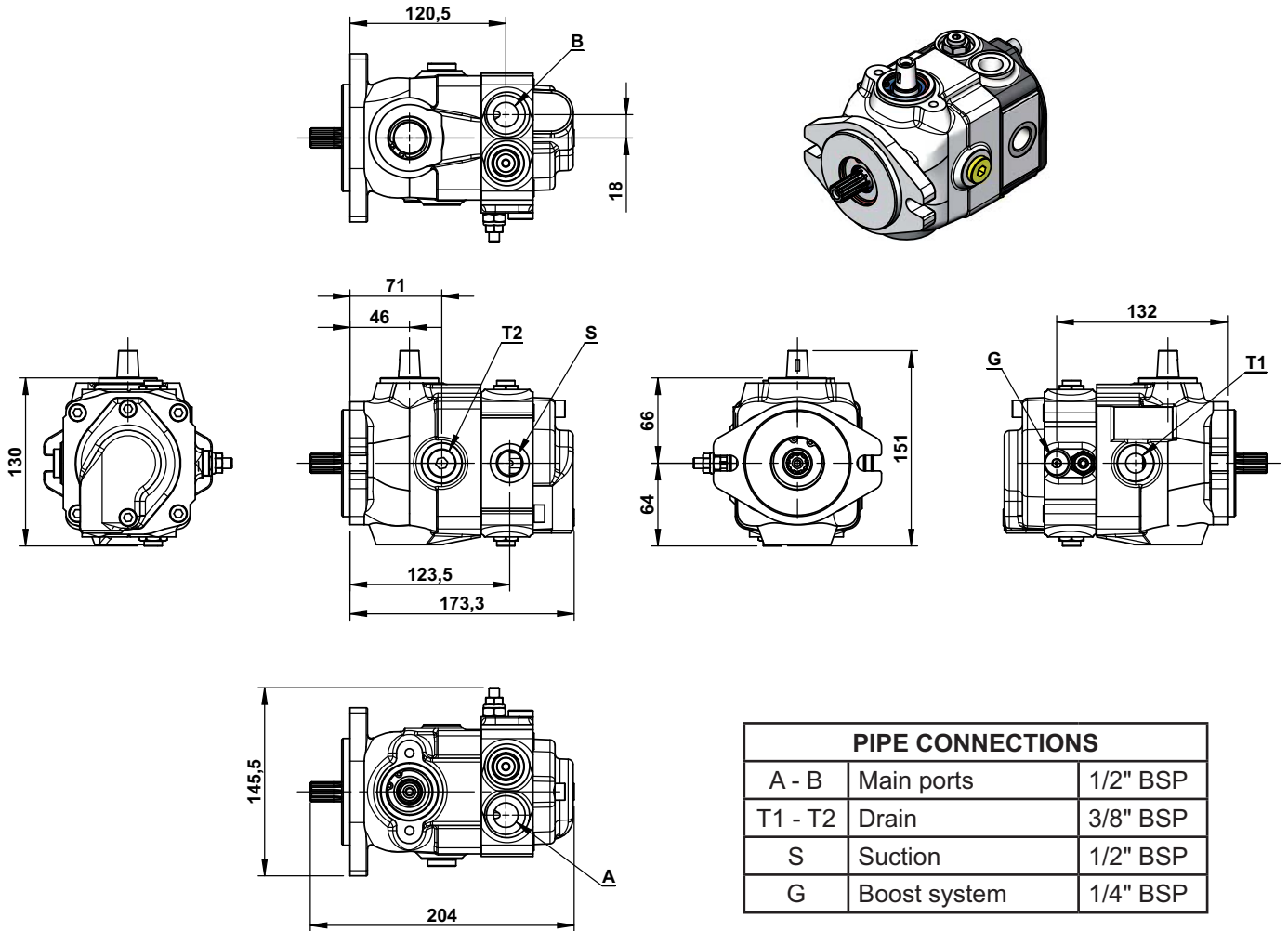

HYDRAULIC DIAGRAM

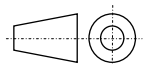
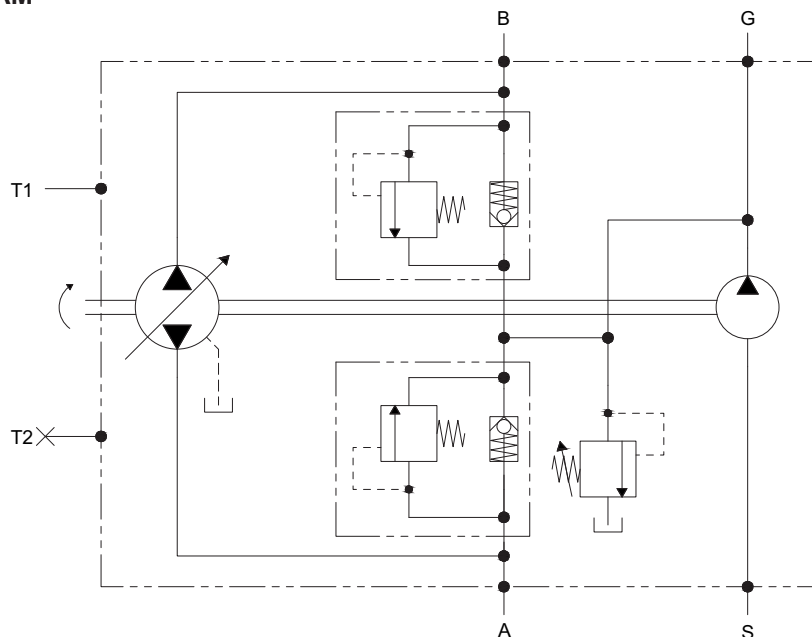

SINGLE PUMP

(Hydraulic servo control)

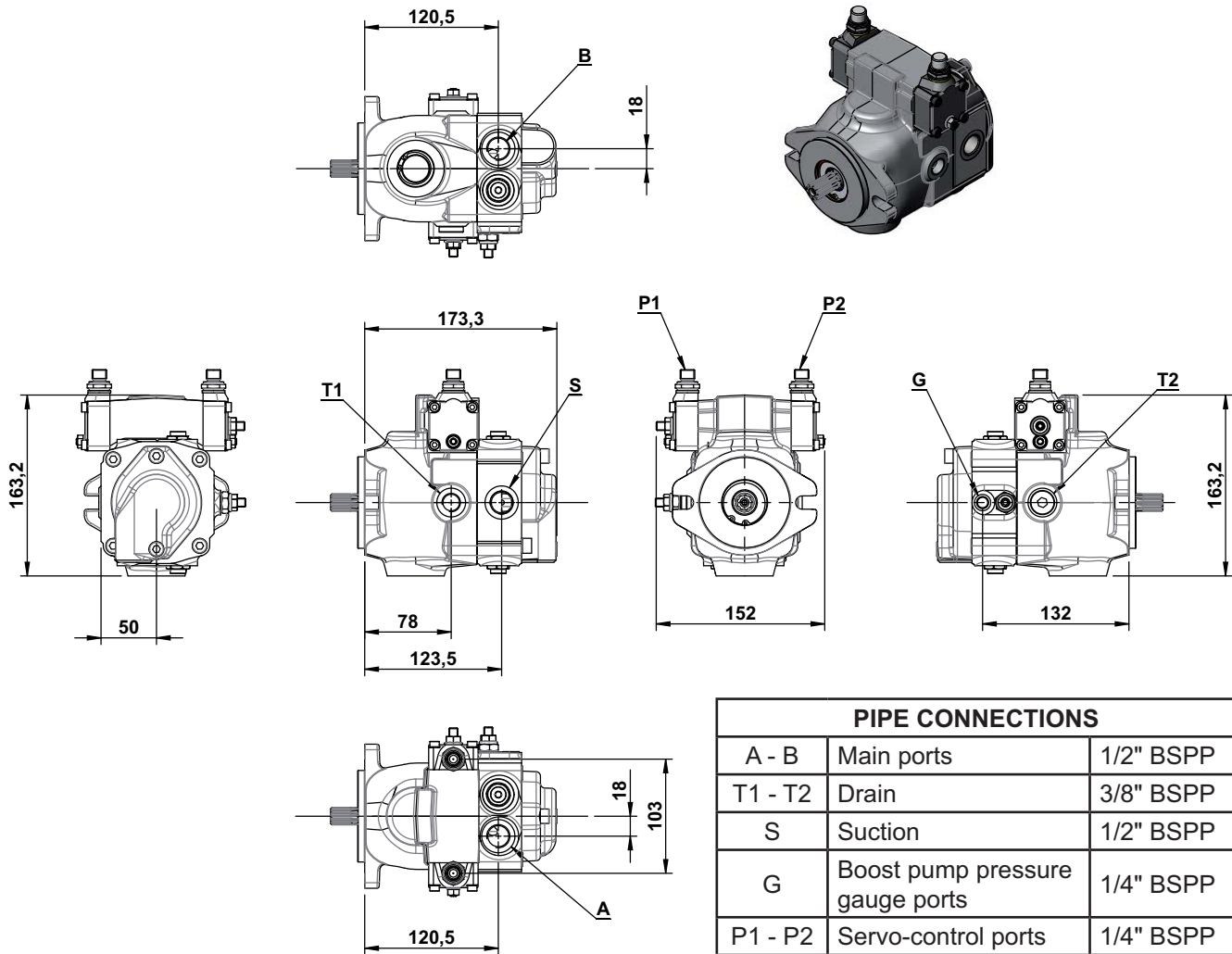

HYDRAULIC DIAGRAM

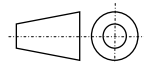
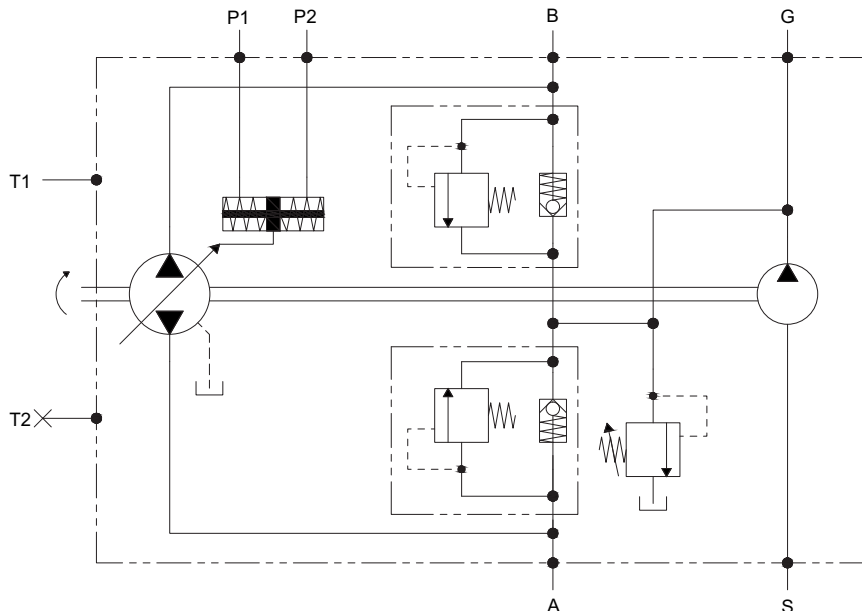

TANDEM PUMP

(Main dimensions)

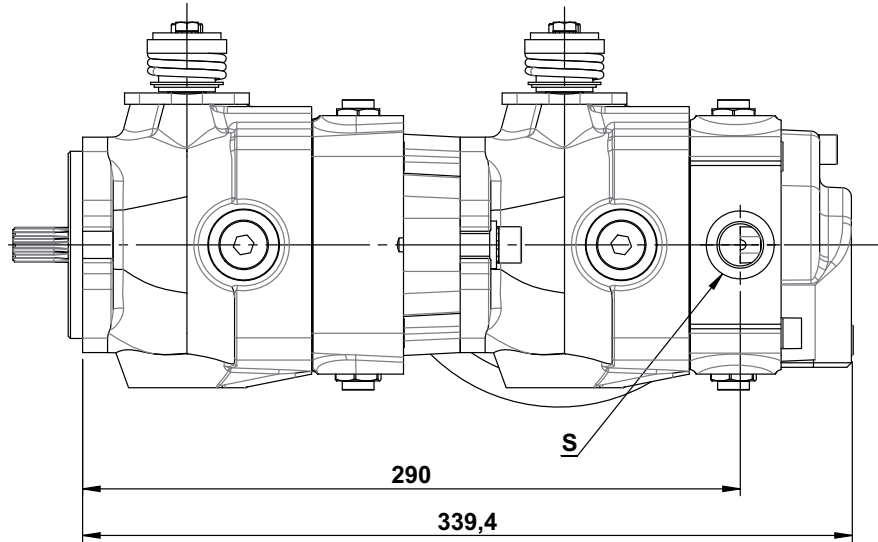

PIPE CONNECTIONS		
A1 - B1	Main ports pump 1	1/2" BSPP
A2 - B2	Main ports pump 2	1/2" BSPP
T	Drain	3/8" BSPP
S	Suction	1/2" BSPP
G	Boost pump pressure gauge ports	1/4" BSPP

For the technical specification, please refer to the single pump

HYDRAULIC DIAGRAM

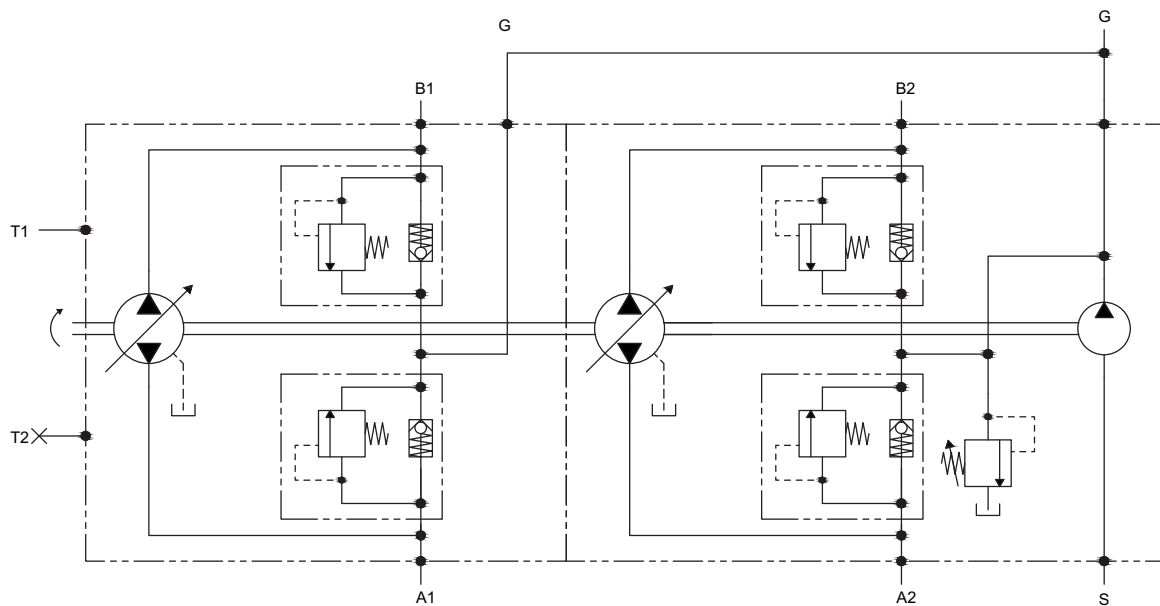

TRIPLE PUMP

(Main dimensions)

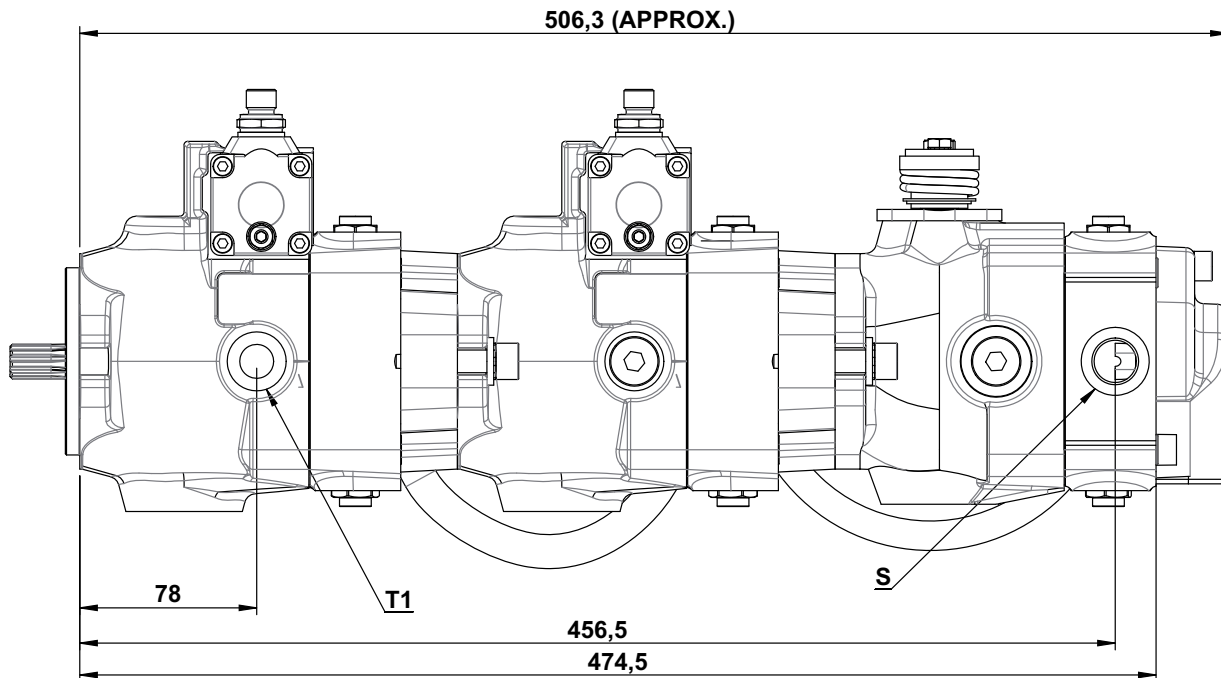

PIPE CONNECTIONS		
A1 - B1	Main ports pump 1	1/2" BSPP
A2 - B2	Main ports pump 2	1/2" BSPP
A3 - A2	Main ports pump 3	1/2" BSPP
T	Drain	3/8" BSPP
S	Suction	1/2" BSPP
G	Boost pump pressure gauge ports	1/4" BSPP

For the technical specification, please refer to the single pump

HYDRAULIC DIAGRAM

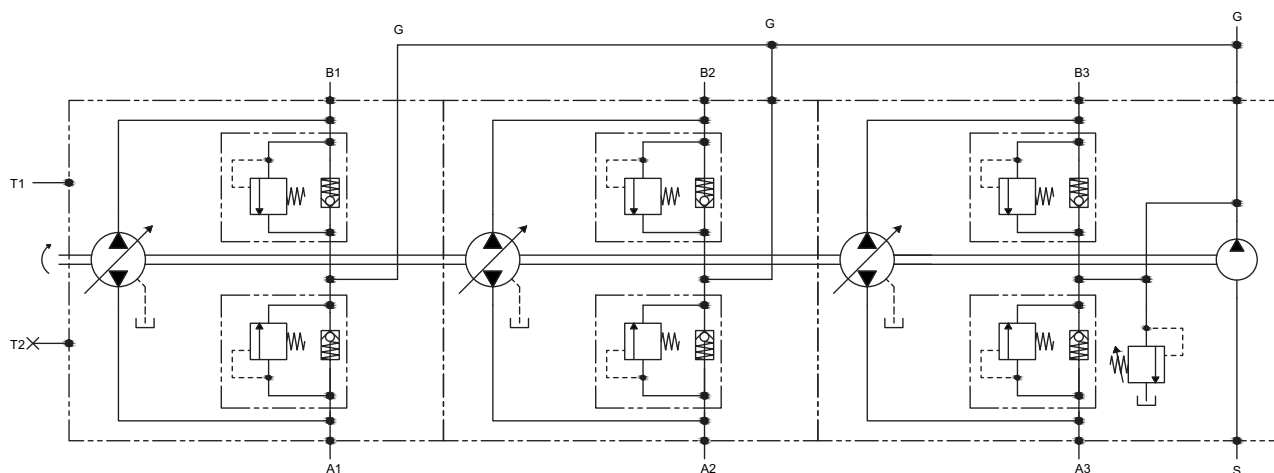

This page has deliberately left blank.

DRIVE SHAFTS

SS2

SPLINED SHAFT Z = 9

Max. torque = 120 Nm

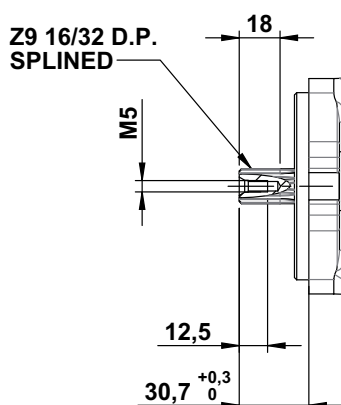

PS1

PARALLEL KEYED SHAFT 15,875 mm. diam.

Max. torque = 65 Nm

(available only for single pump)

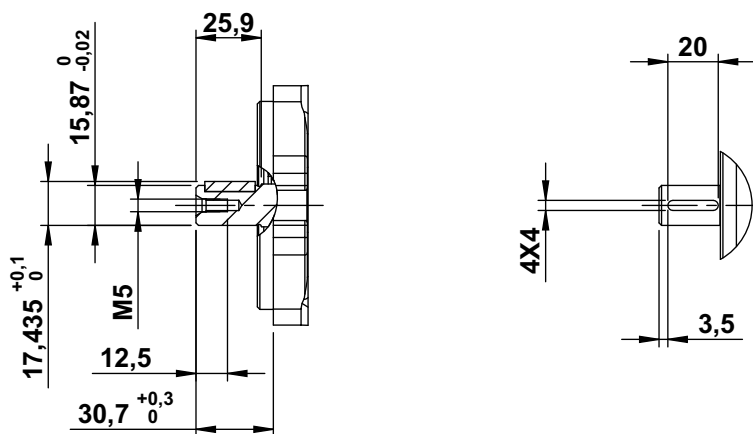

(continued)
DRIVE SHAFTS

PS3

PARALLEL KEYED SHAFT 18 MM. DIAM.

Max. torque = 85 Nm

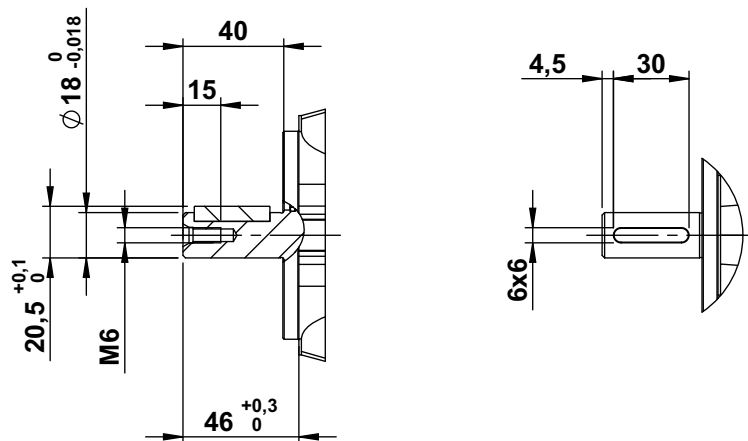

SS3

SPLINED SHAFT Z = 13

(available only for SHI, SEI and F2.1)

Max. torque = 320 Nm

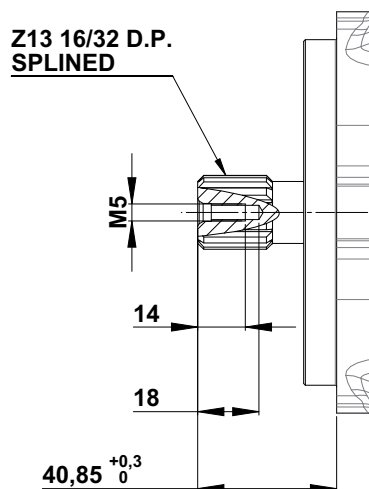

Attention: for the application of multiple pumps the total absorbed torque must not exceed the shown value.

MOUNTING FLANGE

F1

SAE-A - 2 BOLT FLANGE

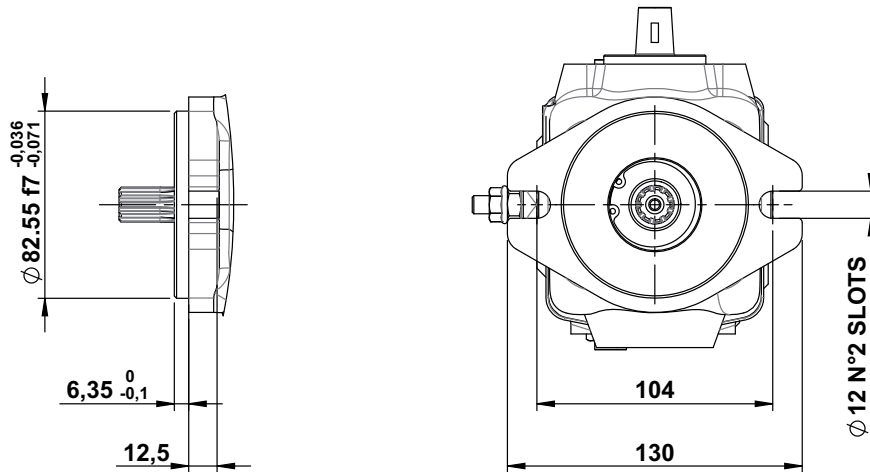

F2.1

SAE-B - 2 BOLT FLANGE

(available only for SHI, SEI and SS3)

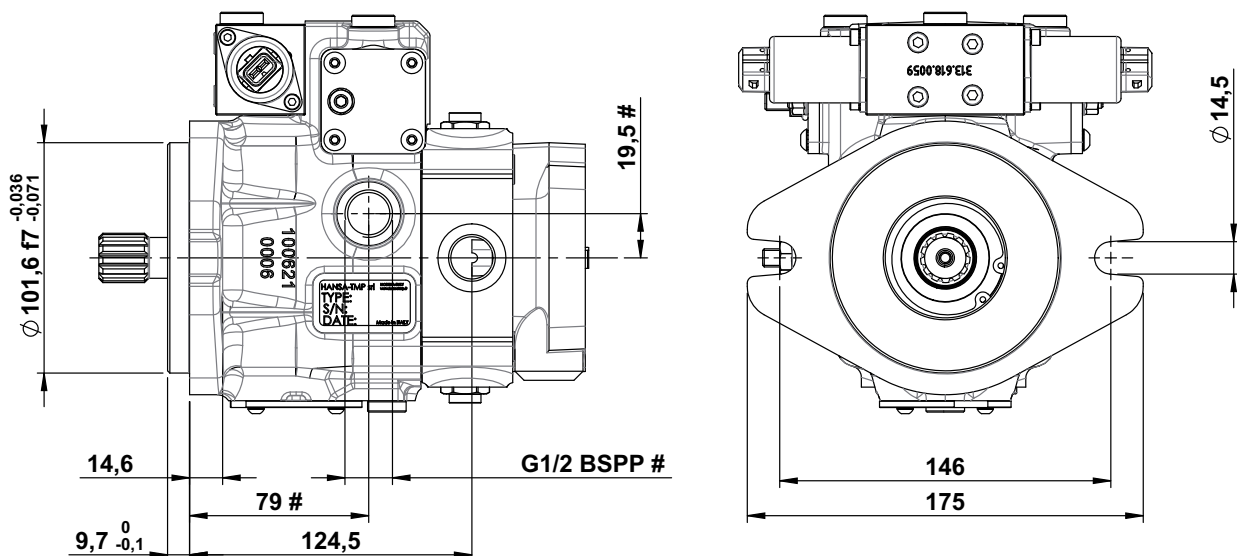

Valid only for version F2.1

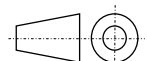

DM

DIRECT MECHANICAL WITHOUT CONTROL LEVER

The change of pump displacement is given by clockwise or counter-clockwise rotation of the shaft of the swashplate.

The shaft is directly linked with the swashplate.

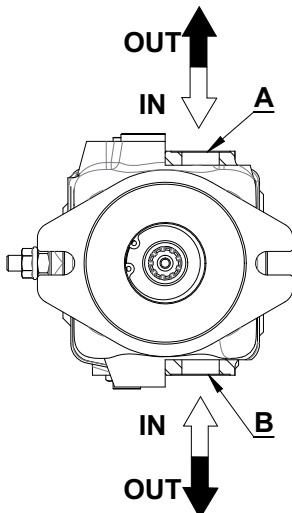
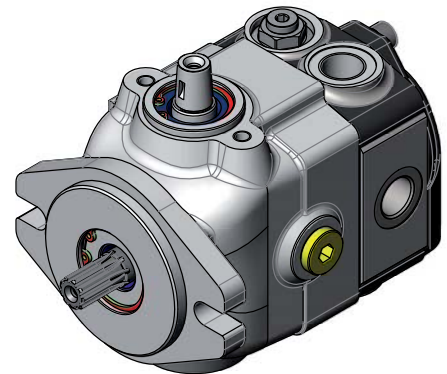
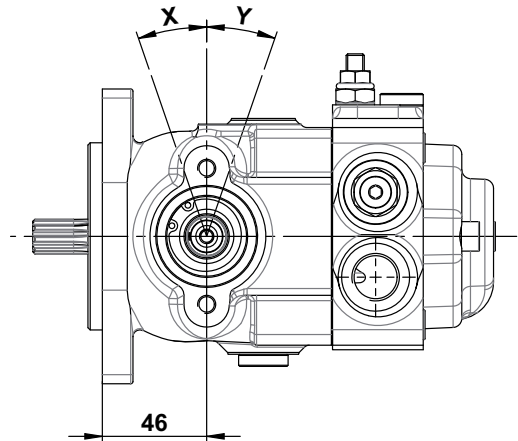
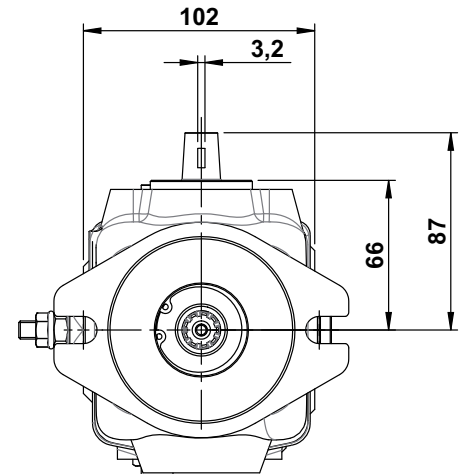
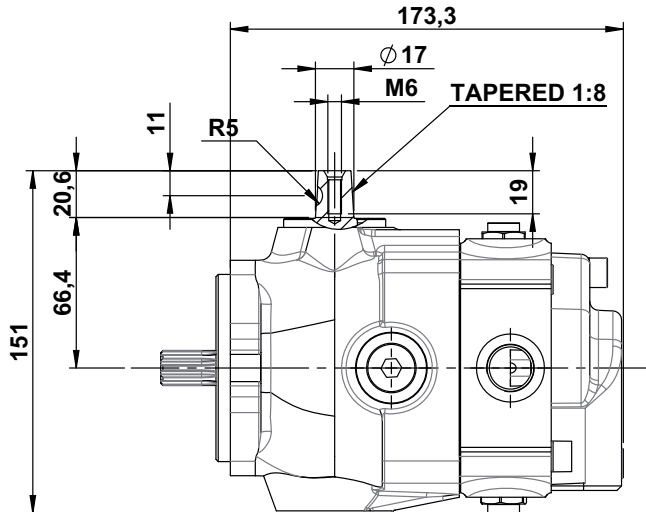

FLOW DIRECTION	PUMP		
	Lever position	OUT	IN
Clockwise CR	X	A	B
	Y	B	A
Counter-clockwise CC	X	B	A
	Y	A	B

Valid for all type of direct controls



BC

TAPERED BUSH

Tapered bush with woodruff key, external cylindrical.
Suitable for arrangement of specific control levers.

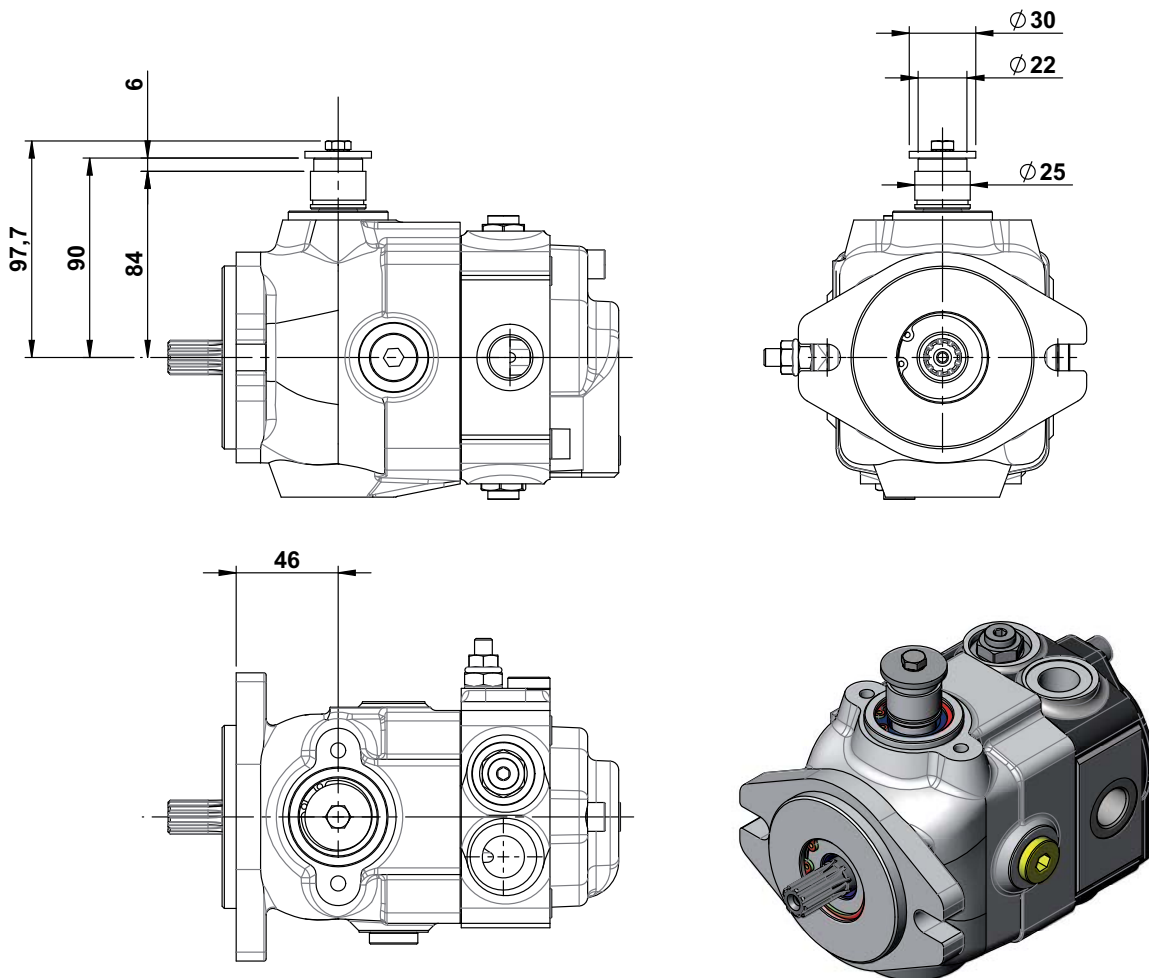

LC

DIRECT MECHANICAL CONTROL WITH LEVER

The pump displacement variation is given by clockwise or counter-clockwise movement of the lever. The lever shaft is directly linked to the swashplate.

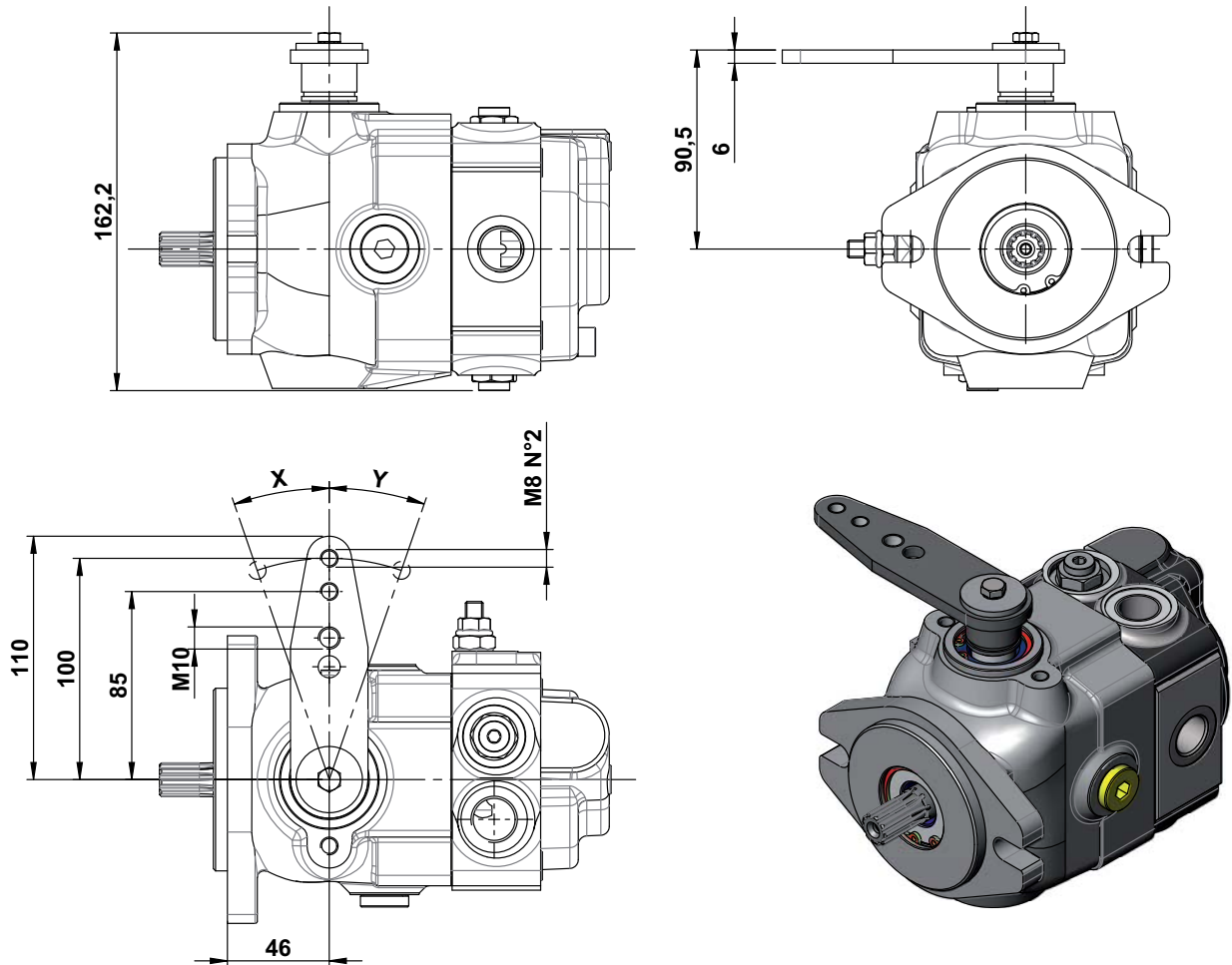

Lever Angle											
Pump Model	6 / 7	8 / 7	9 / 7	11 / 7	12 / 7	13 / 7	15 / 9	17 / 9	18 / 9	19 / 9	21 / 9
Lever Angle (X - Y)	10°	12°	13°	15°	17°	18°	15°	17°	18°	19°	19°

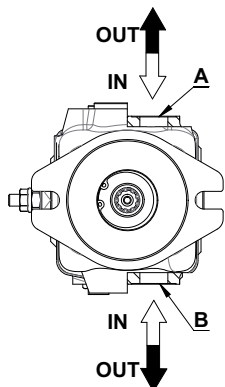

FLOW DIRECTION	PUMP		
	Lever position	OUT	IN
Clockwise CR	X	A	B
	Y	B	A
Counter-clockwise CC	X	B	A
	Y	A	B



DMS

CONTROL LEVER WITH RETURN TO ZERO FLOW POSITION

(torsion spring)

The pump displacement variation is given by a clockwise or counter-clockwise movement of the lever.

Return to zero flow is obtained by a spring which is part of the leverism.

The lever shaft is directly linked to the swashplate.

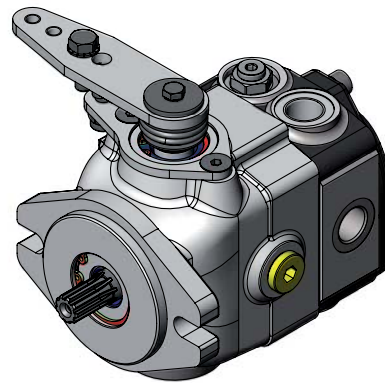
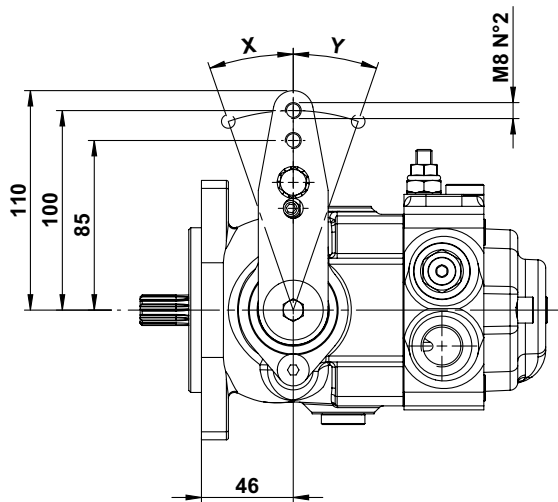
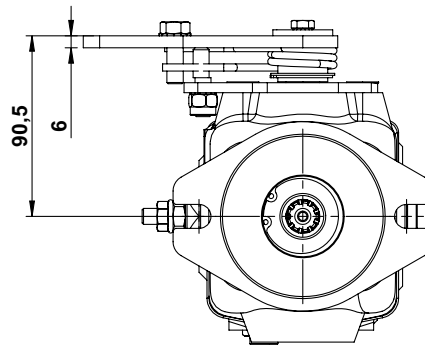
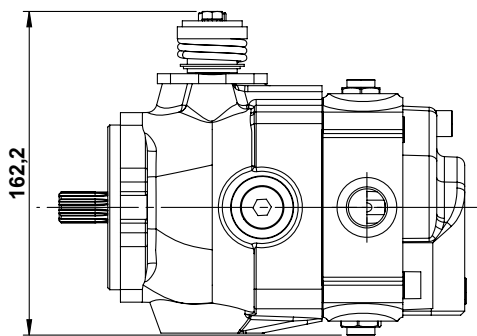

Lever Angle

Pump Model	6 / 7	8 / 7	9 / 7	11 / 7	12 / 7	13 / 7	15 / 9	17 / 9	18 / 9	19 / 9	21 / 9
Lever Angle (X - Y)	10°	12°	13°	15°	17°	18°	15°	17°	18°	19°	19°

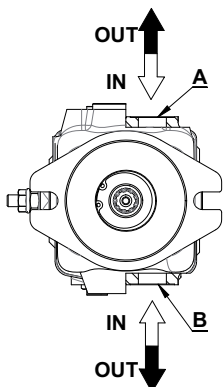

FLOW DIRECTION	PUMP		
	Lever position	OUT	IN
Clockwise CR	X	A	B
	Y	B	A
Counter-clockwise CC	X	B	A
	Y	A	B



(continued)

DMS

CONTROL LEVER WITH RETURN TO ZERO FLOW POSITION

(torsion spring)

HYDRAULIC DIAGRAM

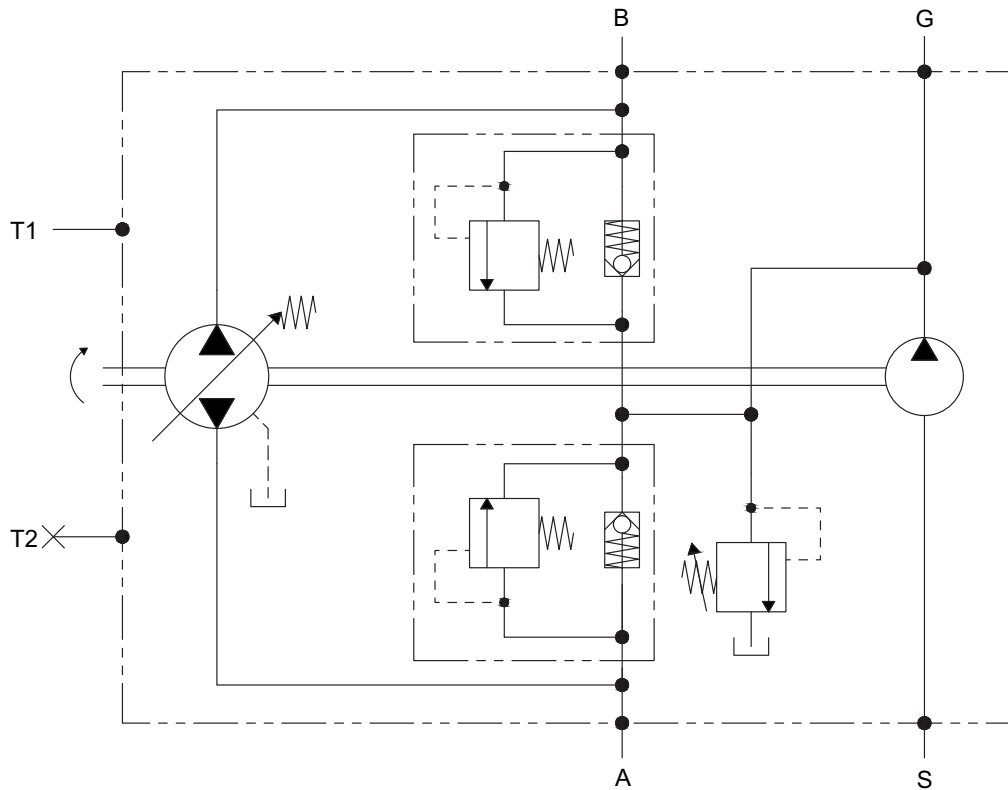

Standard spring diameter: **3,6 mm**
Other available diameters: **3 - 3,3 - 4 - 5 mm**

Lever force - 10 MPa

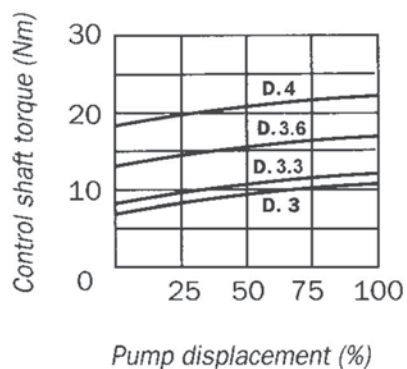

Lever force - 20 MPa

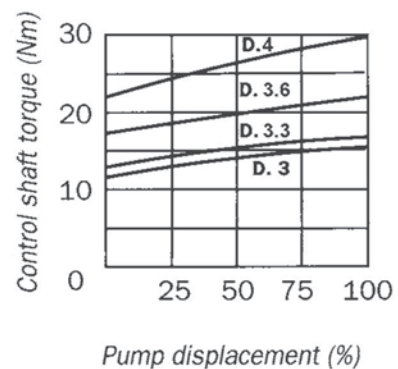

DMZ

CONTROL LEVER WITH RETURN TO ZERO FLOW POSITION

(compression spring)

The pump displacement variation is given by a clockwise or counter-clockwise movement of the lever.

Return to zero flow is obtained by a spring which is part of the leverism.

The lever shaft is directly linked to the swashplate.

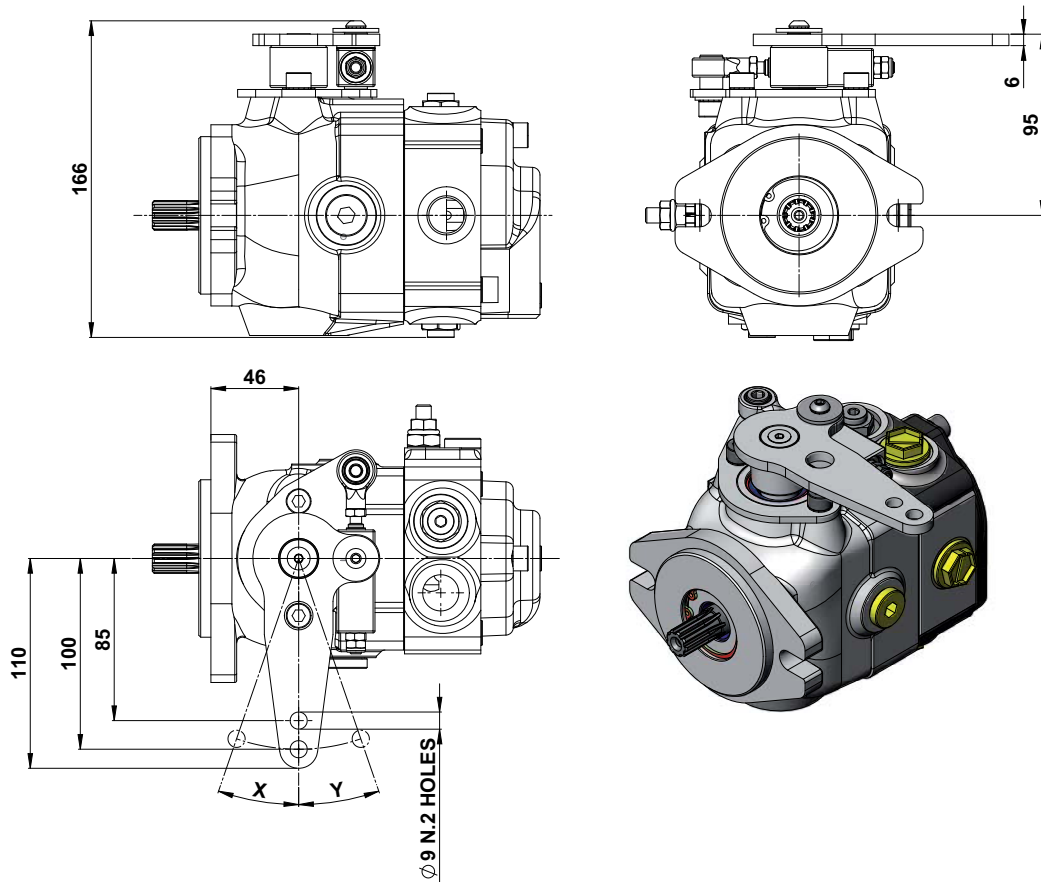

Lever Angle

Pump Model	6 / 7	8 / 7	9 / 7	11 / 7	12 / 7	13 / 7	15 / 9	17 / 9	18 / 9	19 / 9	21 / 9
Lever Angle (X - Y)	10°	12°	13°	15°	17°	18°	15°	17°	18°	19°	19°

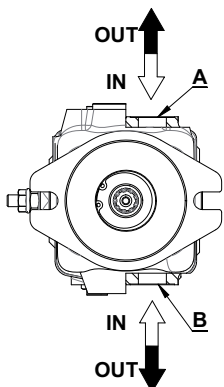

FLOW DIRECTION	PUMP		
	Lever position	OUT	IN
Pump rotation	X	A	B
	Y	B	A
Clockwise CR	X	B	A
	Y	A	B



(continued)

DMZ

CONTROL LEVER WITH RETURN TO ZERO FLOW POSITION

(compression spring)

HYDRAULIC DIAGRAM

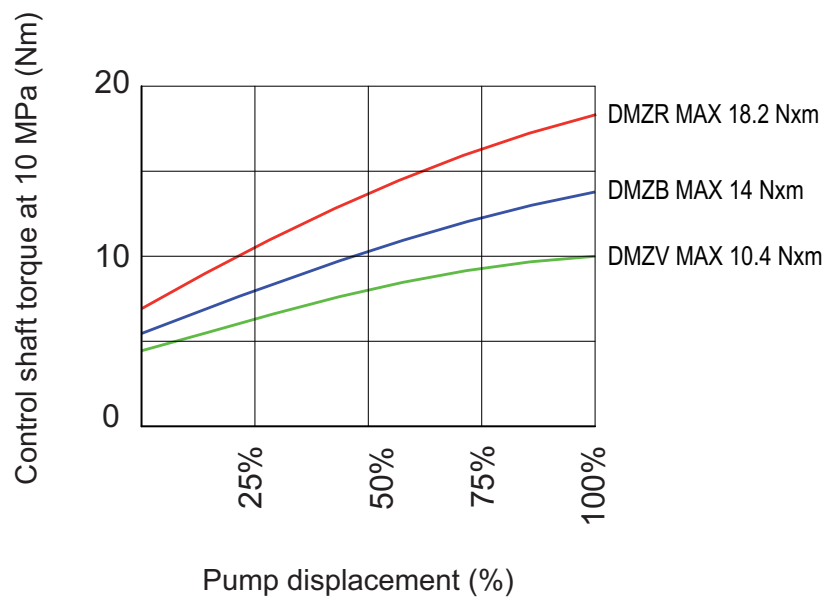
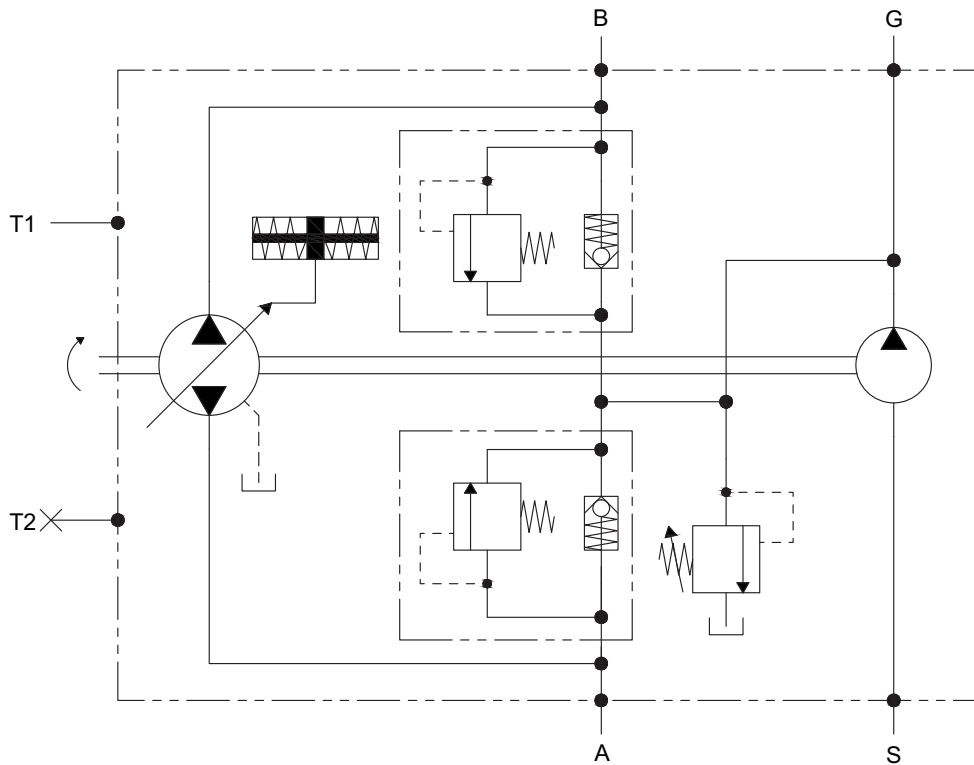

SHI

HYDRAULIC SERVO-CONTROL

The variation in pump displacement is obtained by adjusting the pressure on the P1-P2 servo control connections by means of a hydraulic proportional joystick (containing pressure reducing valves).

The oil supply for the joystick can be obtained by taking pressure from the boost pump (G port), see pag. 10.

The servo control reacting time can be adjusted by inserting a restrictor on the joystick supply line (0,5 ÷ 1,2 mm).

The servo control operation curve in both control directions goes from 0,4 to 1,8 MPa (tolerance ± 5%).

The adjustment curve of the hydraulic control system has to be wider (0,3 ÷ 1,9 MPa).

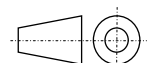
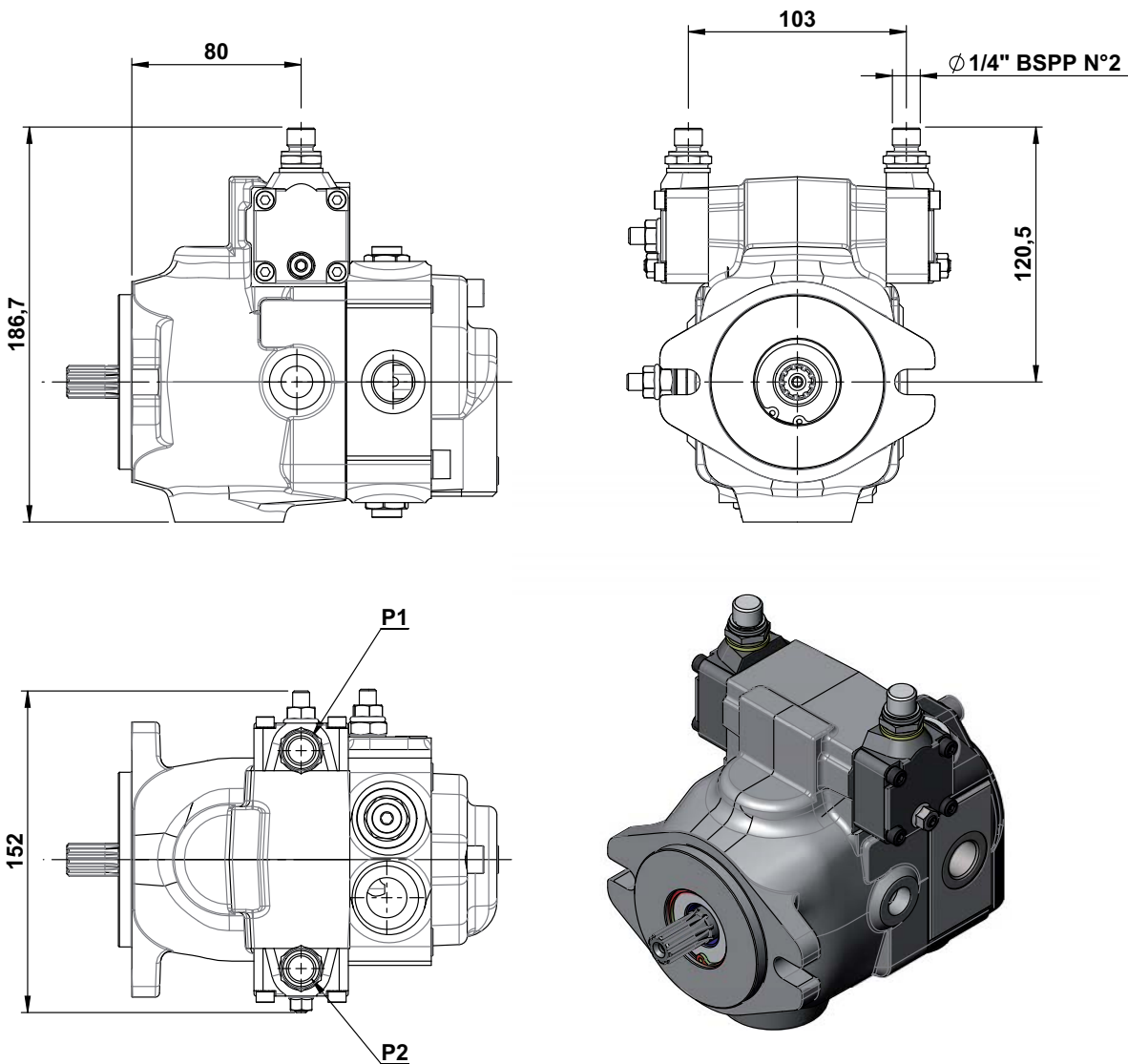

(continued)

SHI

HYDRAULIC REMOTE SERVO-CONTROL

HYDRAULIC DIAGRAM

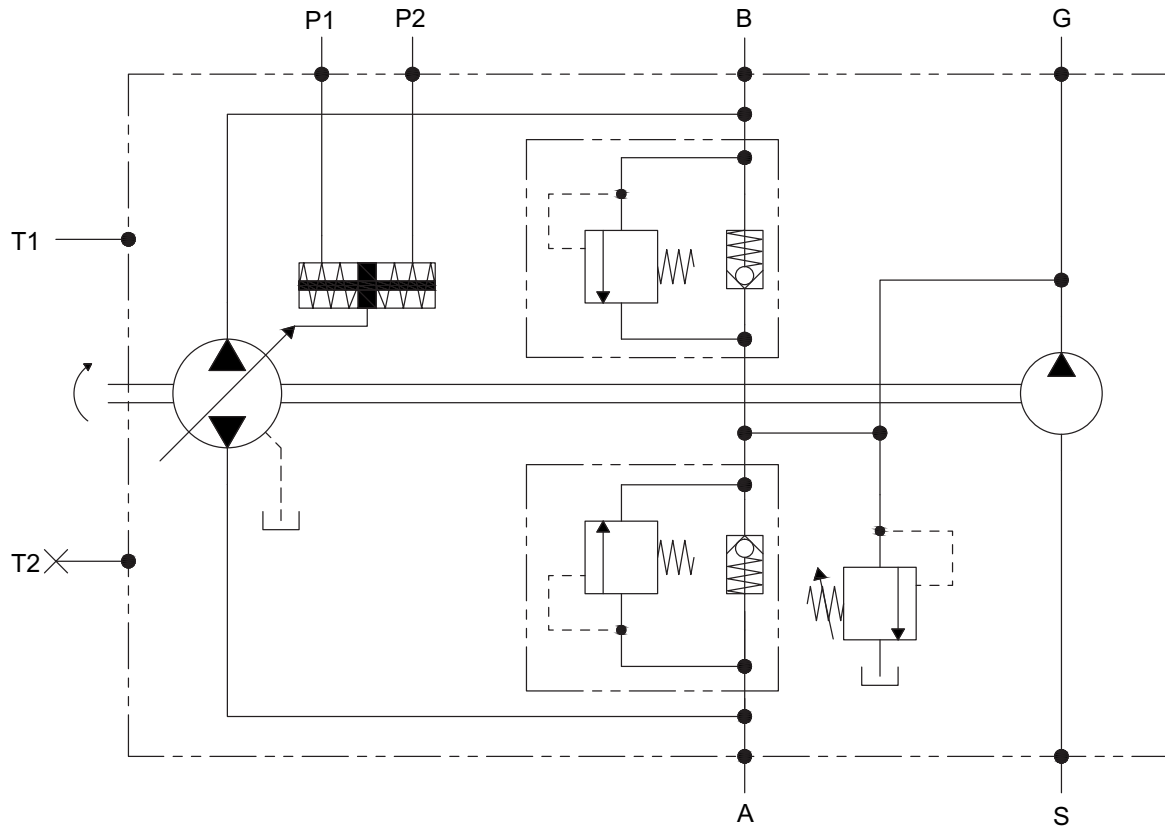

SERVO PRESSURE - DISPLACEMENT GRAPHIC

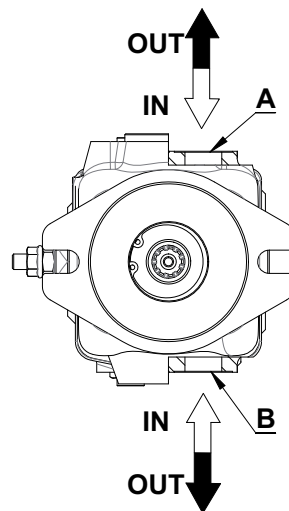
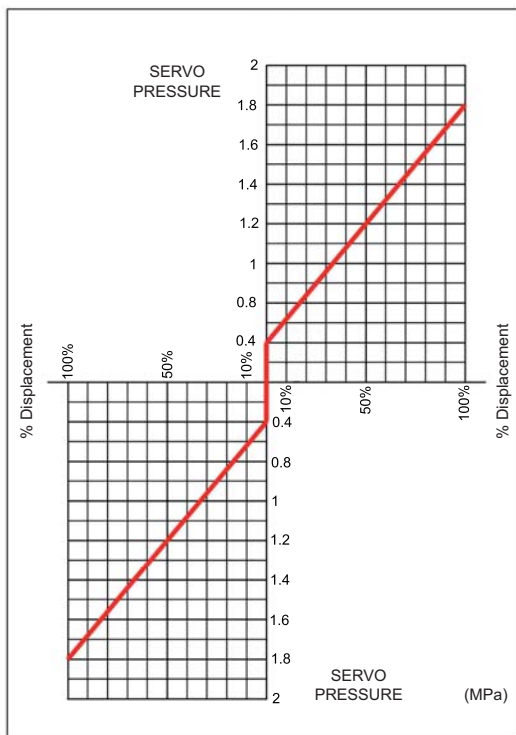

FLOW DIRECTION	PUMP		
	Port	OUT	IN
Rotation			
Clockwise (CR)	P ₁	B	A
	P ₂	A	B
Counter clockwise (CC)	P ₁	A	B
	P ₂	B	A

SEI 1.3 (12V DC)

SEI 2.3 (24V DC)

ELECTRO-PROPORTIONAL SERVO-CONTROL

(with AMP Junior Timer connector)

The pump displacement variation is obtained by an electric signal, which varies:

- from 0 to 750 mA (supply voltage 24V DC)
- from 0 to 1500 mA (supply voltage 12V DC)

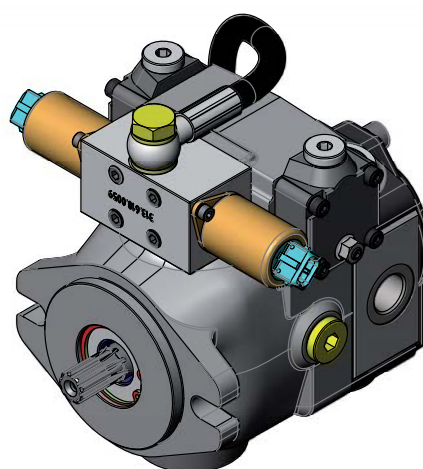
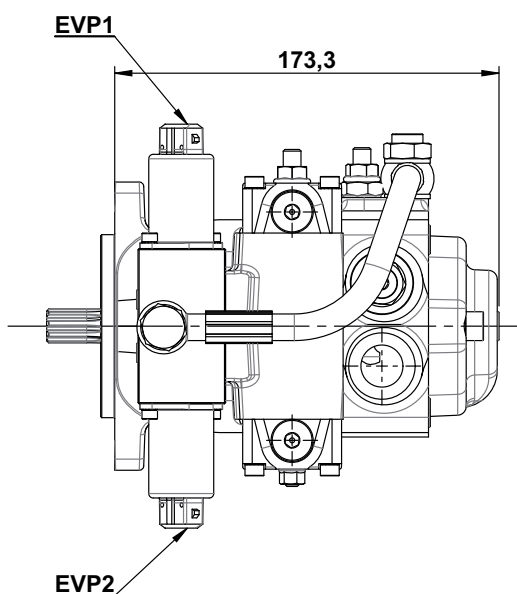
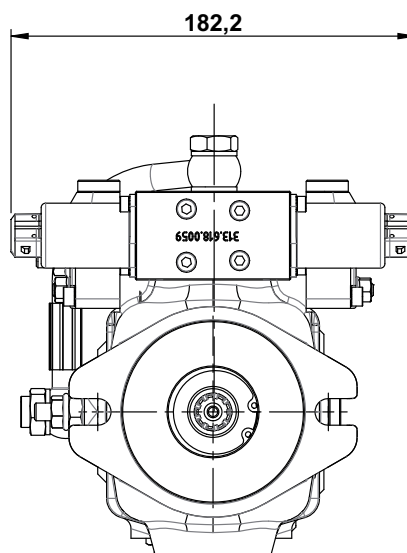
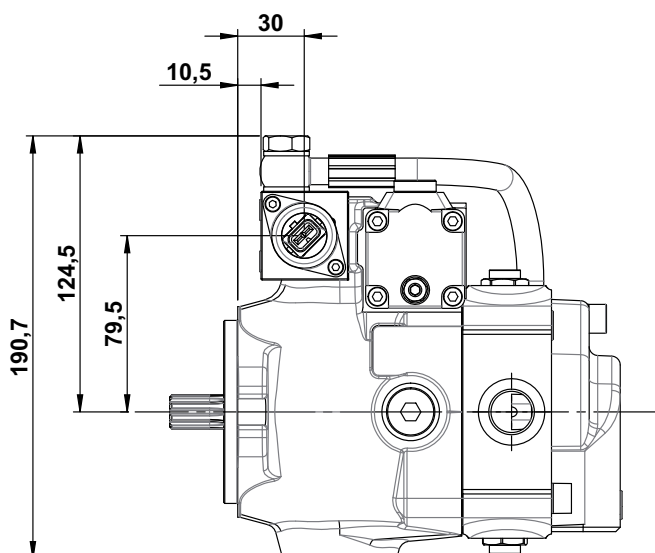

(continued)

SEI 1.3 (12V DC)

SEI 2.3 (24V DC)

ELECTRO-PROPORTIONAL SERVO-CONTROL

(with AMP Junior Timer connector)

HYDRAULIC DIAGRAM

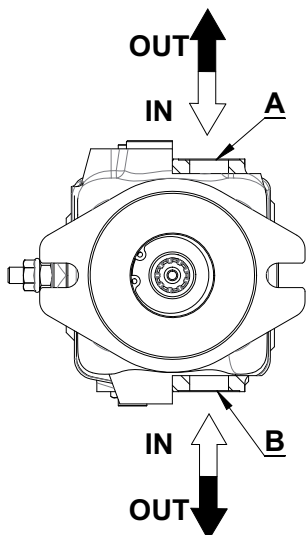
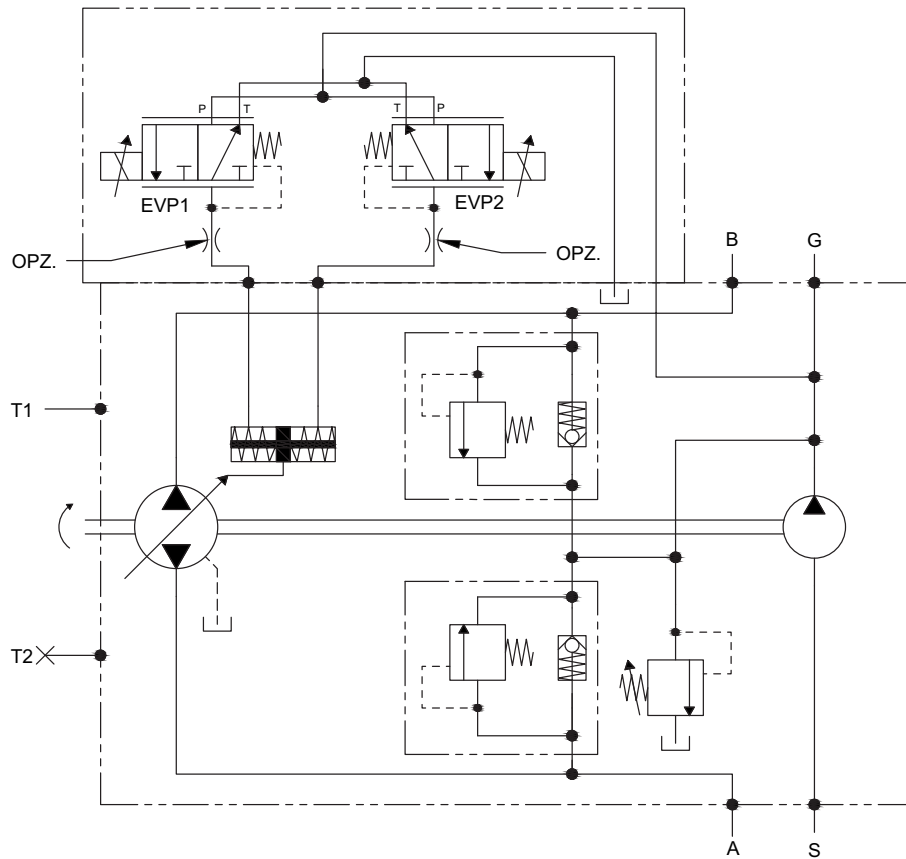

FLOW DIRECTION	PUMP		
	 EVP	OUT	IN
Rotation			
Clockwise (CR)	EVP1 EVP2	B A	A B
Counter clockwise (CC)	EVP1 EVP2	A B	B A

(continued)

SEI 1.3 (12V DC)

SEI 2.3 (24V DC)

ELECTRO-PROPORTIONAL SERVO-CONTROL

(with AMP Junior Timer connector)

CURRENT-DISPLACEMENT GRAPHIC

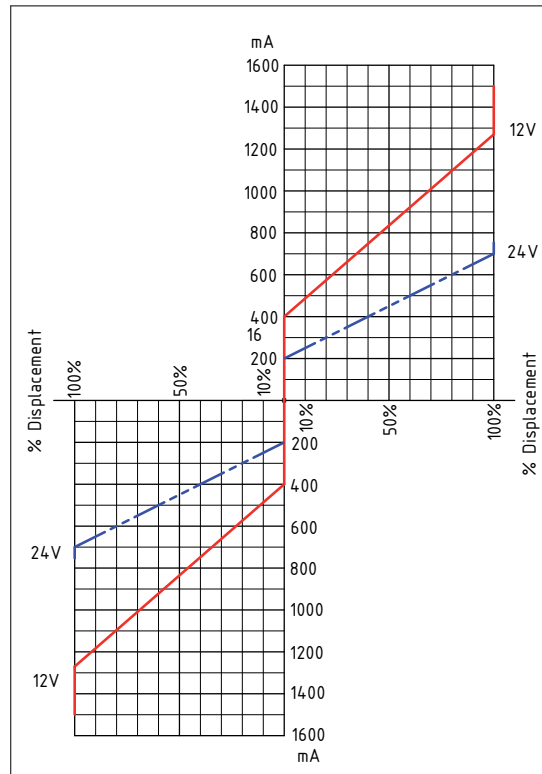

ELECTRICAL FEATURES		
Voltage	12 V	24 V
Electric current max.	1500 mA	750 mA
Load resistance	4,72 Ω ± 5%	20,8 Ω ± 5%
Type of control	Current control	
	PWM 100 Hz indicated	
Type of connection	AMP Junior Timer	
Protection class	Until IP6K6 / IPX9K	

HYDRAULIC FEATURES	
Max. pressure (P, T)	pP= 5 MPa, pT= 3 MPa
Hysteresis (w/PWM)	<0,07 MPa (pA=2,0)
	<0,1 MPa (pA=2,5)
	<0,15 MPa (pA=3,5)
Filtration ratio	125 μm
Oil contamination level	Min. filtration ratio: 20/18/15
	According ISO 4406
	Hydraulic oil DIN 51524
Min./max. oil temperature	from -40 to +105°C

CONTROL DEVICE POSITION

(Primary and secondary pump)

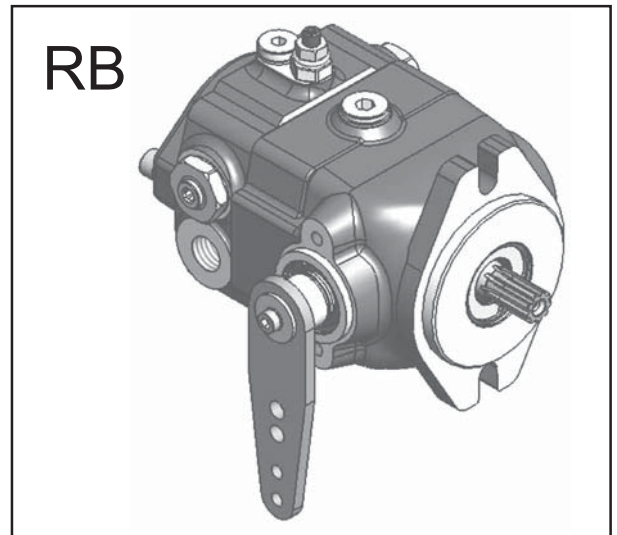
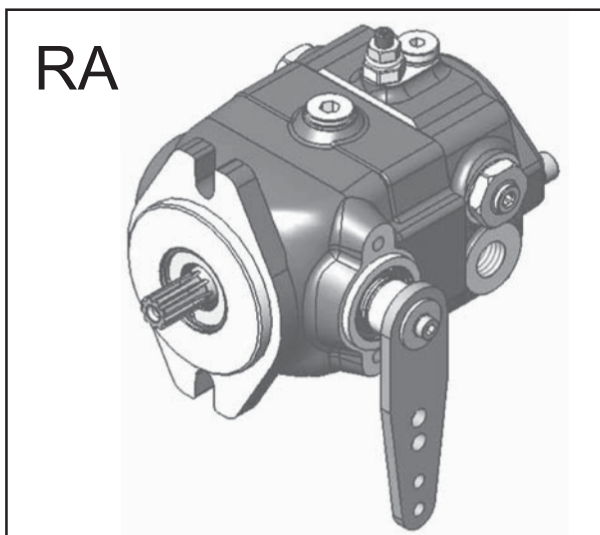
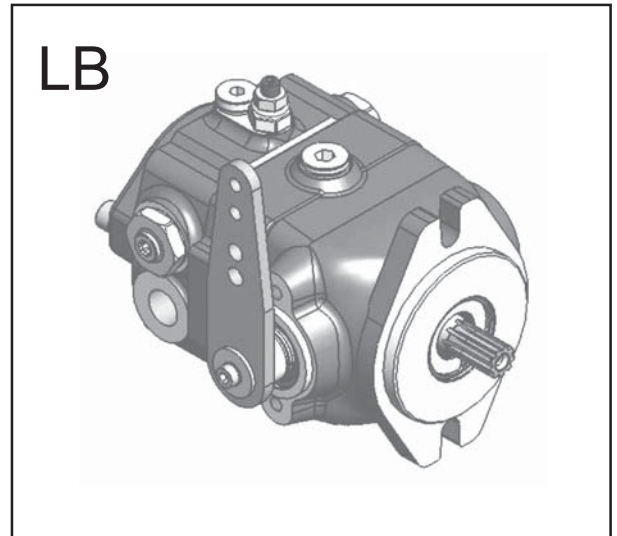
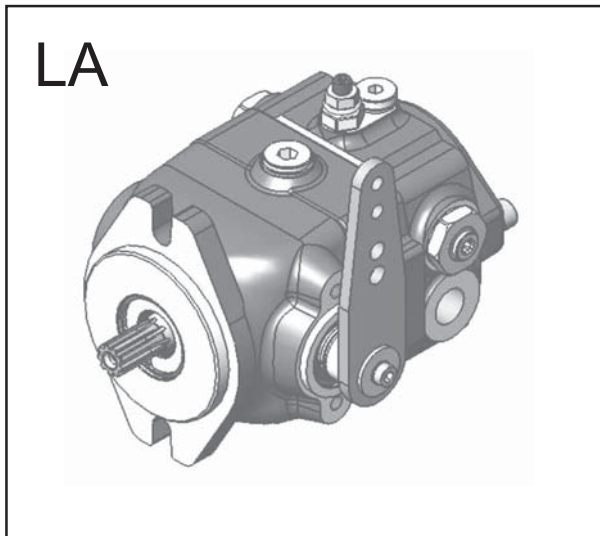
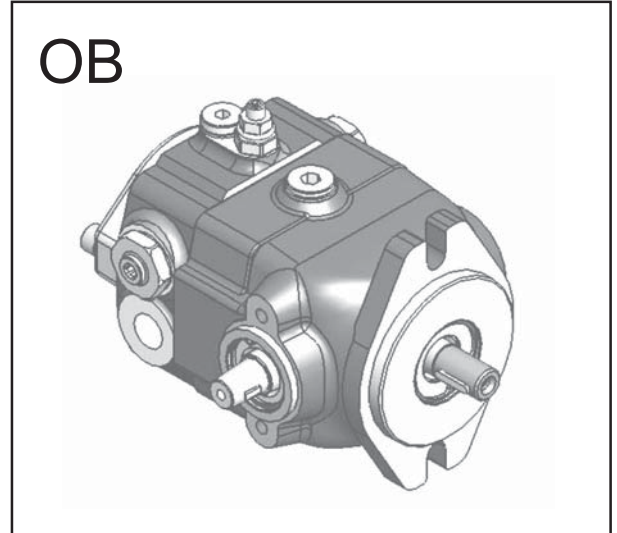
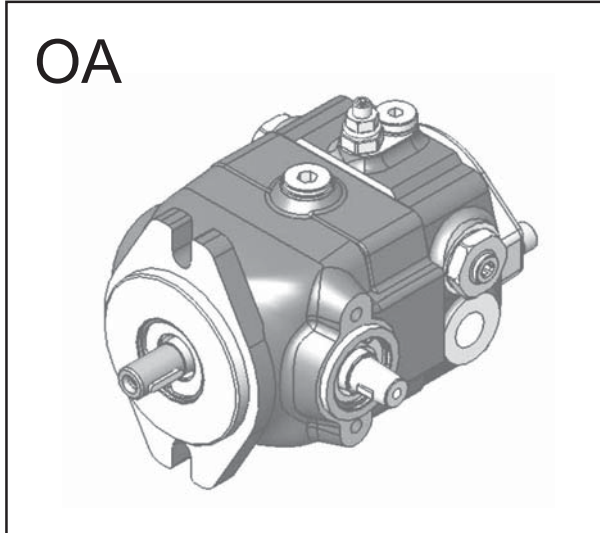

REAR PUMP MOUNTING FLANGES

(Dimensions valid for all versions)

C
CLOSED (WITHOUT CONNECTION FOR REAR PUMP) - STANDARD VERSION

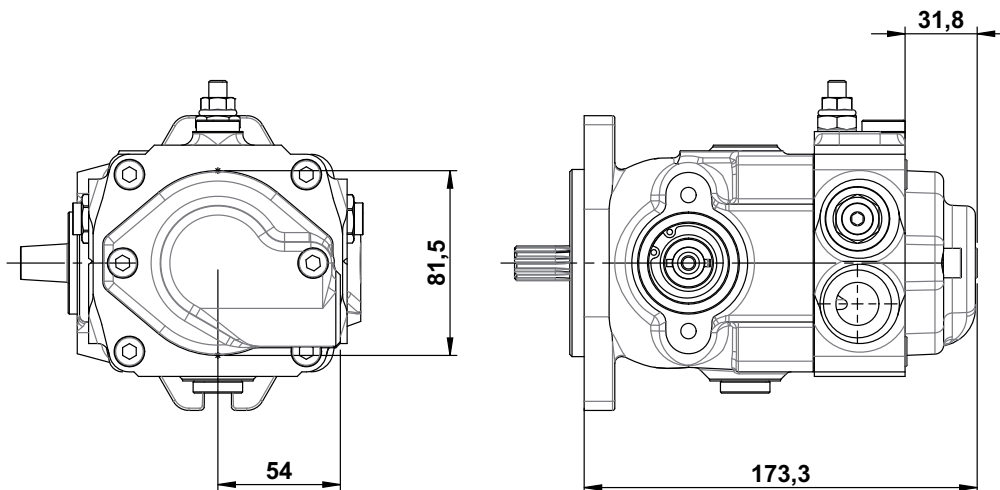

B1
GERMAN STANDARD (WITHOUT BOOST PUMP) COMPACT VERSION

Max. torque = 70 Nm

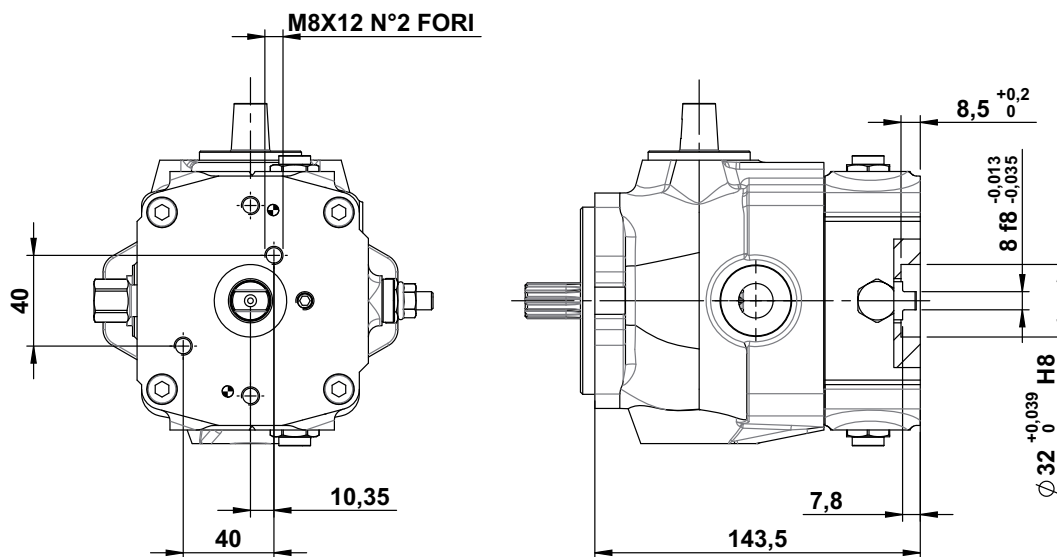

REAR PUMP MOUNTING FLANGES

(Dimensions valid for all versions)

B1

GERMAN STANDARD

Max. torque = 70 Nm

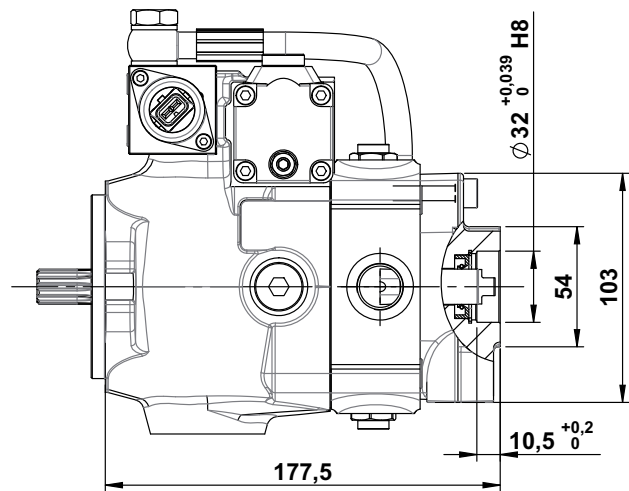
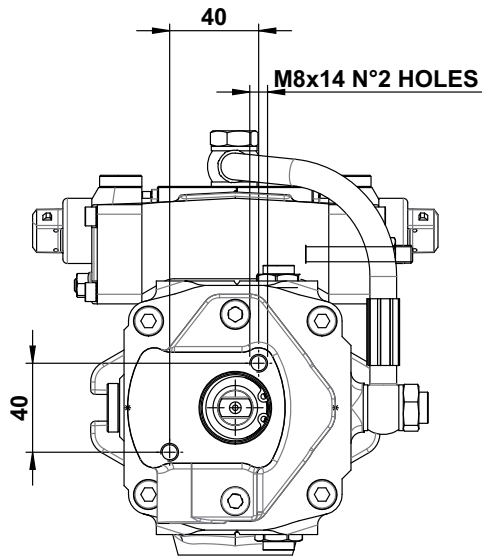

B2

GERMAN STANDARD

Max. torque = 70 Nm

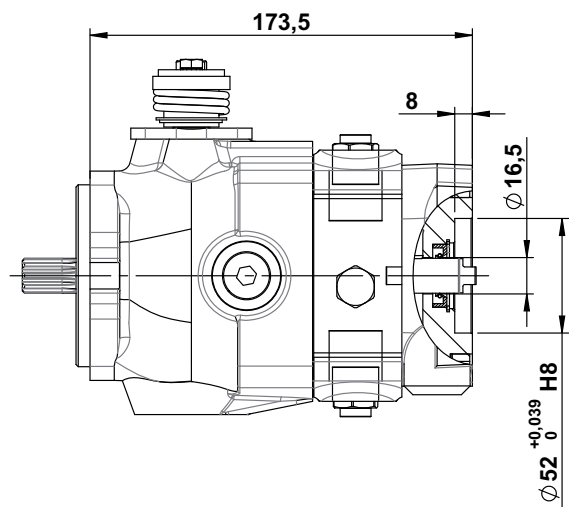
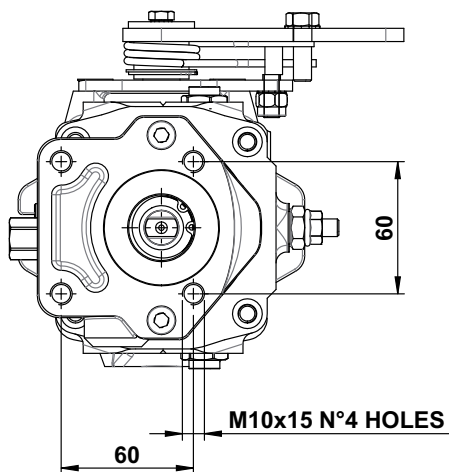

REAR PUMP MOUNTING FLANGES

(Dimensions valid for all versions)

B2

GERMAN STANDARD (WITHOUT BOOST PUMP) COMPACT VERSION

Max. torque = 70 Nm

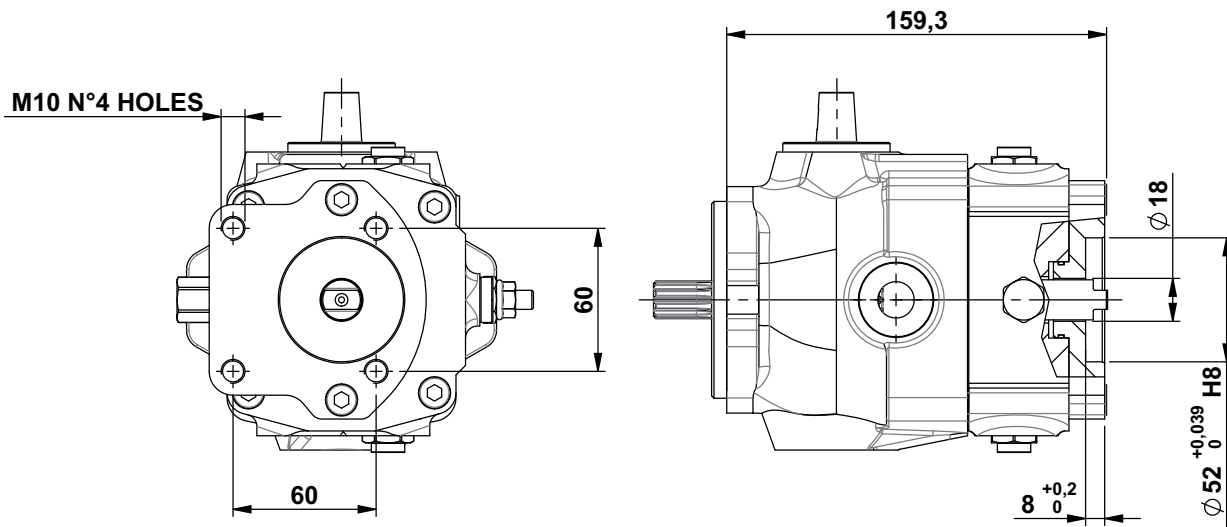

SA-R

SAE-A - 2 BOLT FLANGE

Max. torque = 120 Nm

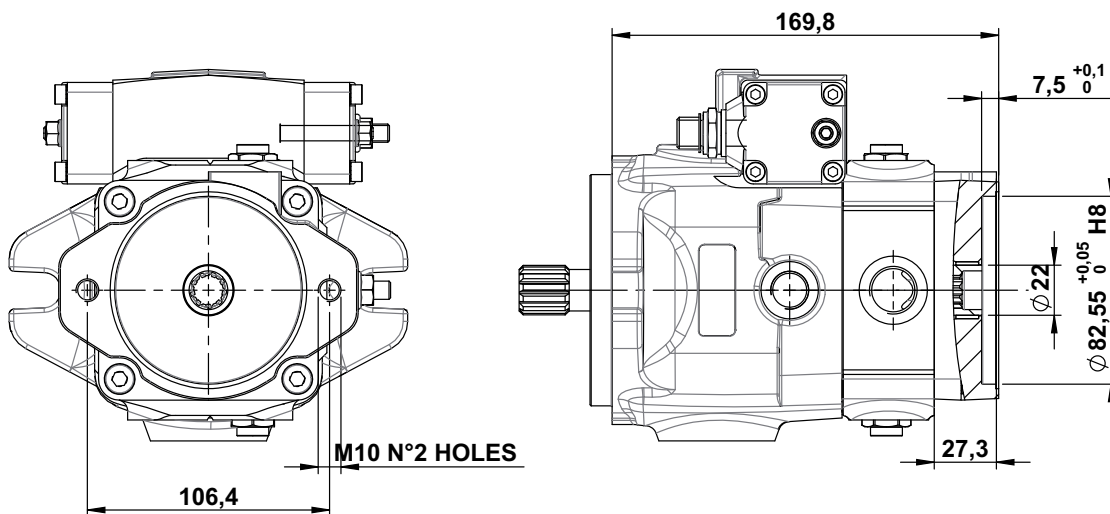

OPTIONAL LB

LEVER BY-PASS

Manual valve to connect the A and B ports together to allow the free-wheeling of the hydraulic motor.

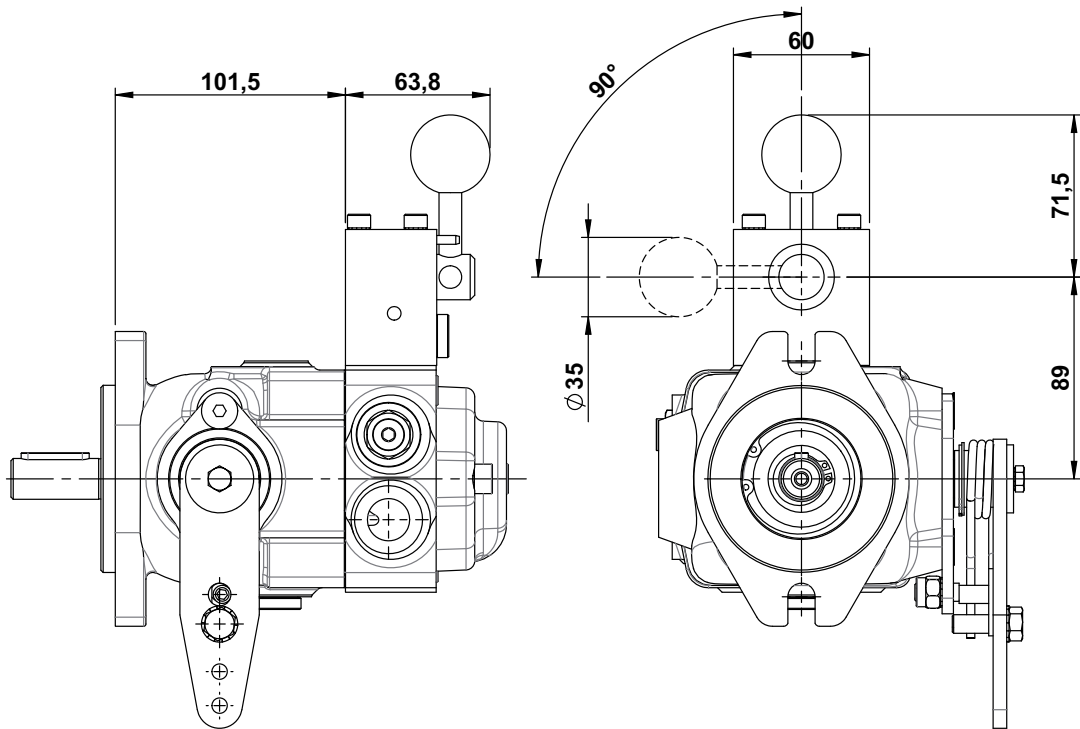

HYDRAULIC DIAGRAM

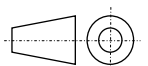
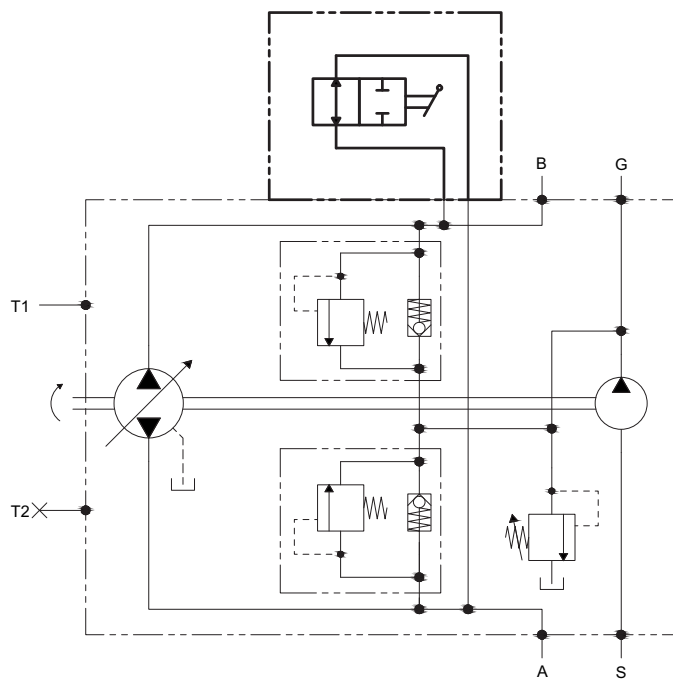

OPTIONAL VS

PURGE VALVE

Subtracting warm oil from the closed circuit, the purge valve allows the flow of cool fluid from the boost system.

Oil flow for cooling = 1,5 lt/min. at 1500 n/min.

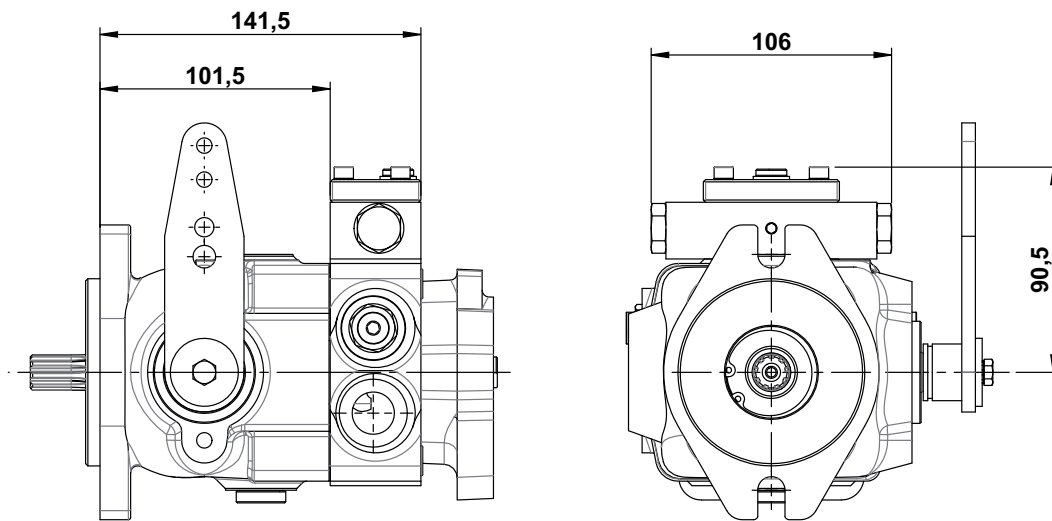

HYDRAULIC DIAGRAM

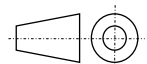
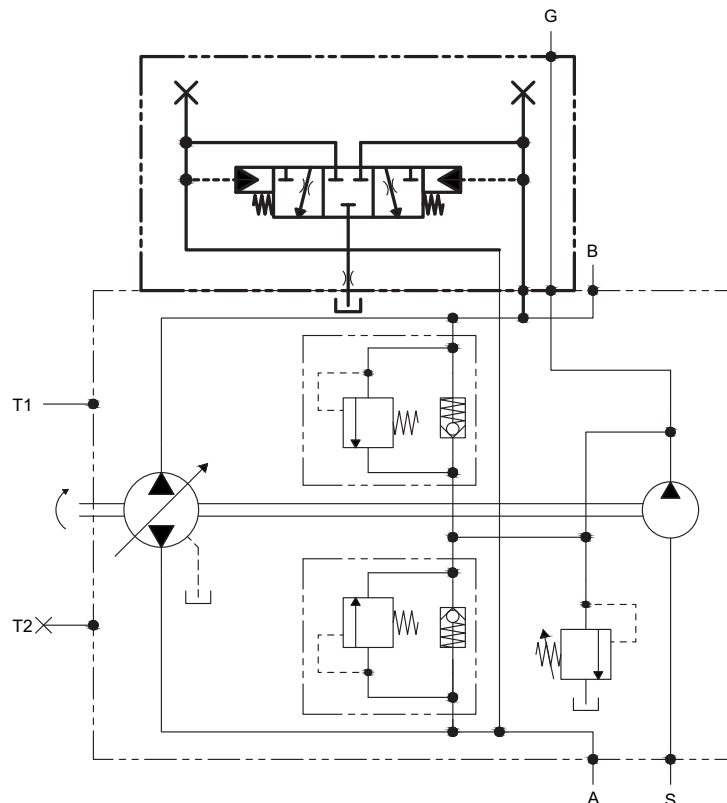

OPTIONAL VSLB

PURGE VALVE + LEVER BY-PASS

The manual valve connects the A and B ports together to allow the free-wheeling of the hydraulic motor.

The purge valve, subtracting warm oil from

the closed circuit, allows the flow of cool fluid from the boost system.

Oil flow for cooling = 1,5 lt/min. at 1500 n/min.

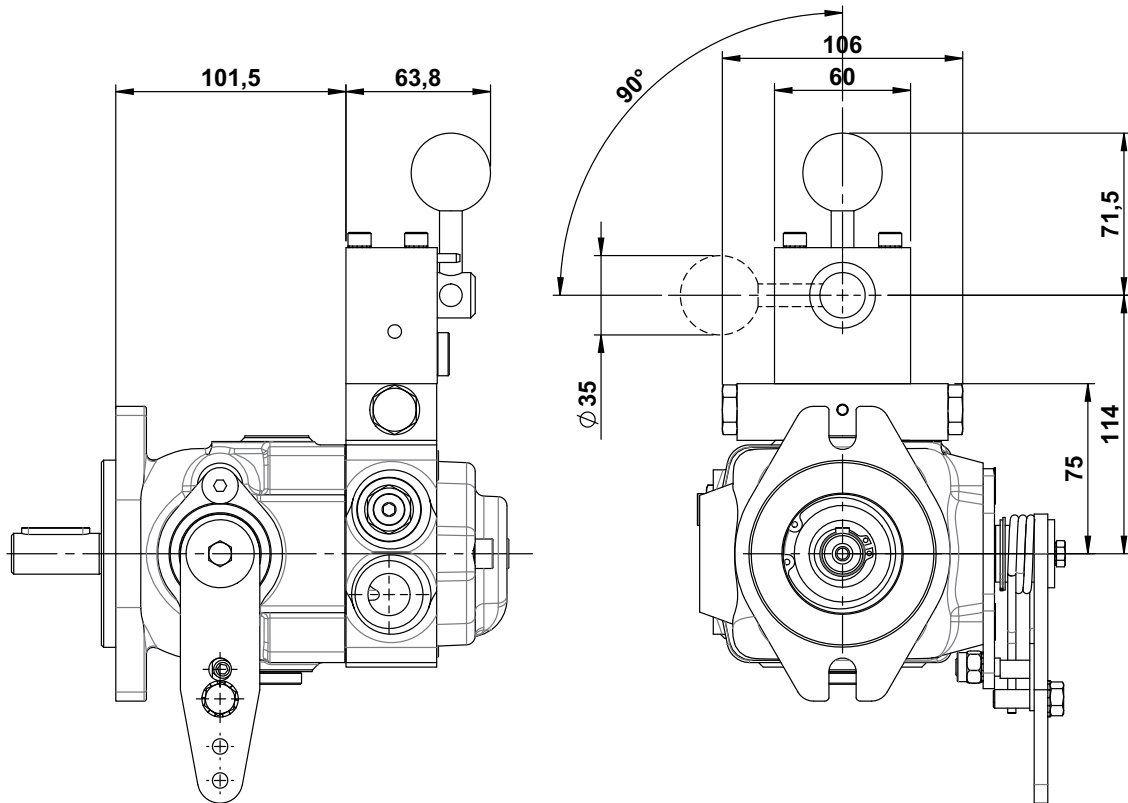

HYDRAULIC DIAGRAM

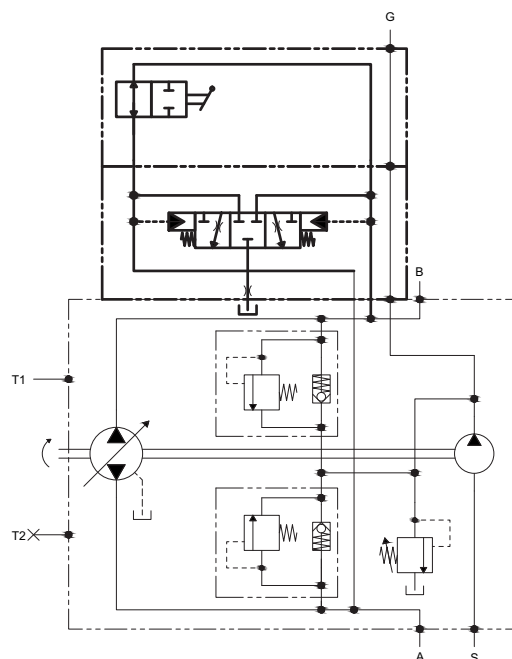

OPTIONAL SB

SCREW BY-PASS

Manual valve to connect the A+B ports together for free rotation of the hydraulic motor.

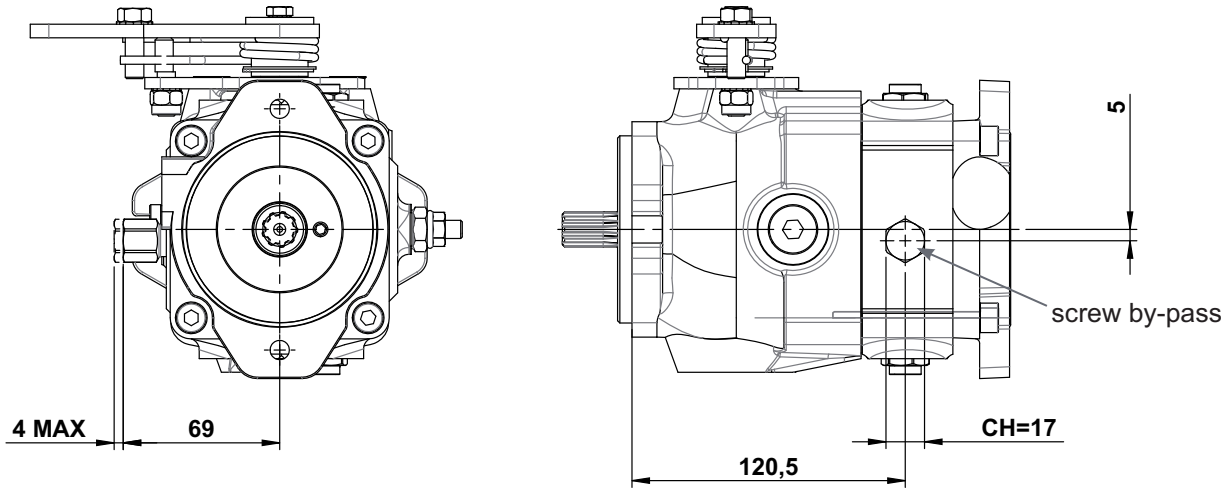

HYDRAULIC DIAGRAM

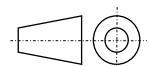
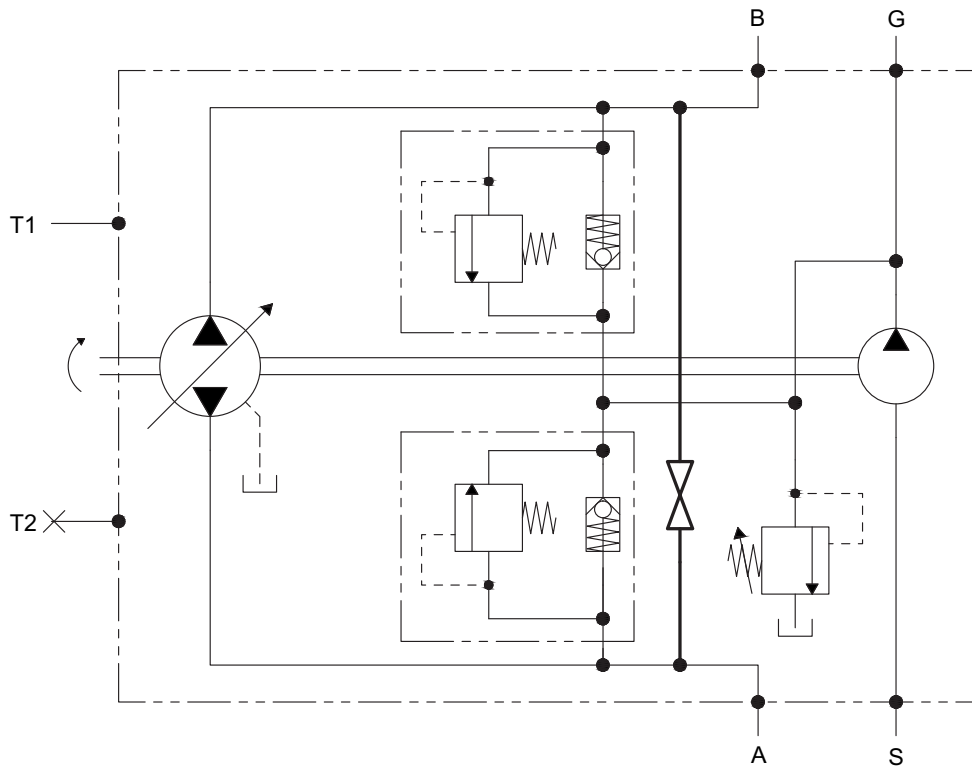

OPTIONAL FB

SAE-A / SAE-B MOUNTING FLANGE (CONVERSION)

Max. torque = 120 Nm

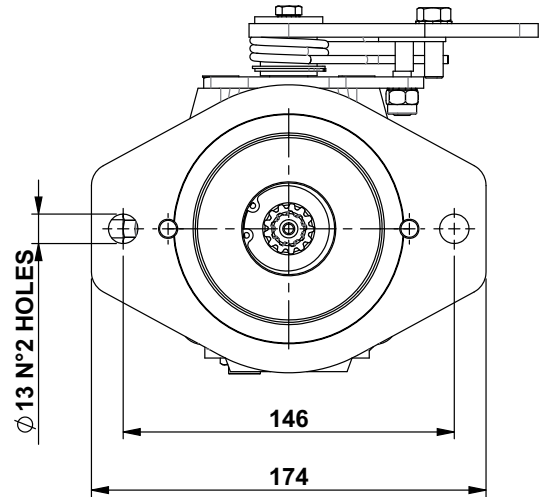
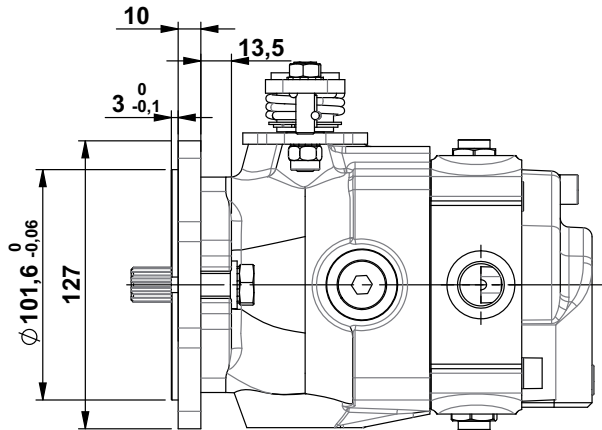

OPTIONAL ST

COUPLING Z = 9 / Z = 13 (SAE-A / SAE-B CONVERSION OF SHAFT)

Max. torque = 120 Nm

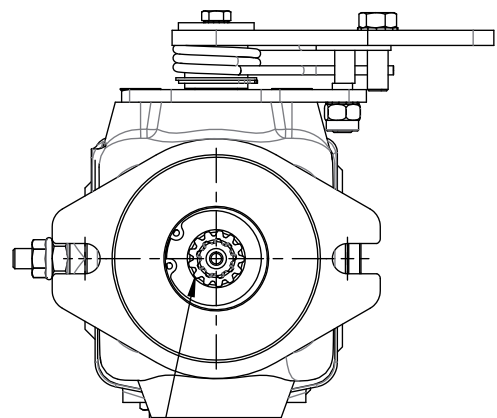
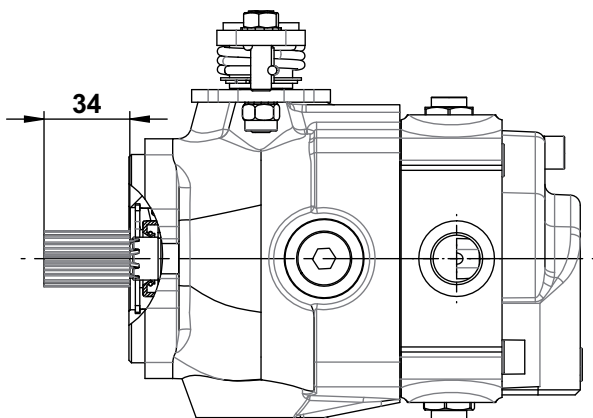

Z13 16/32 D.P.
SPLINED

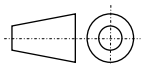

OPTIONAL FBST

SAE-A / SAE-B MOUNTING FLANGE

COUPLING Z = 9 / Z = 13 (SAE-A / SAE-B CONVERSION OF SHAFT)

Max. torque = 120 Nm

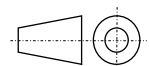
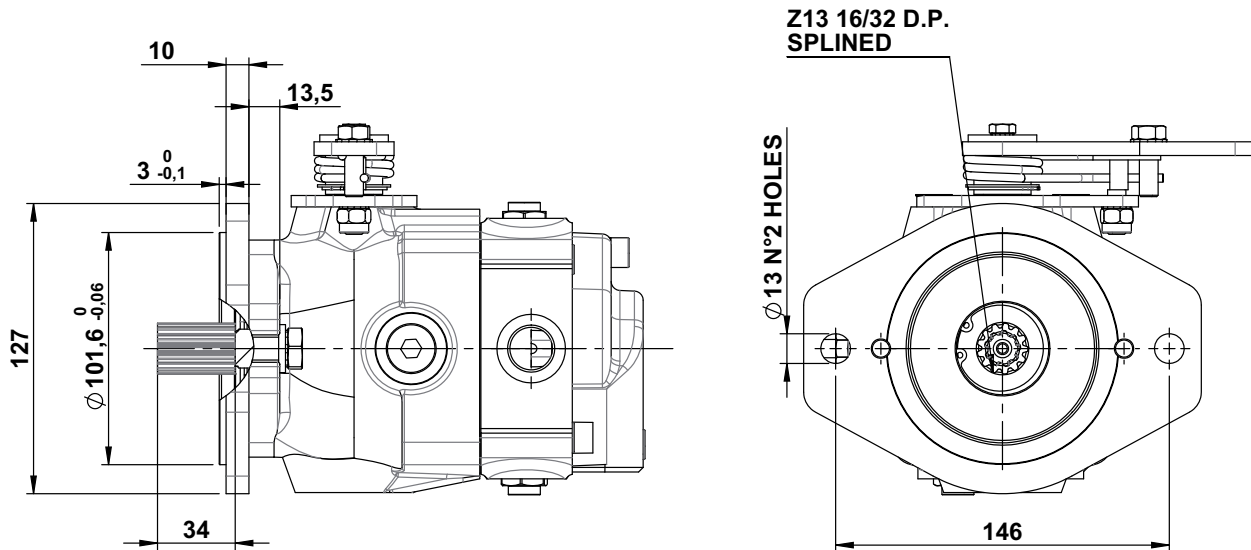

ACCESSORIES

Hydraulic Gear Pump German Standard **B1**
Hydraulic Gear Pump German Standard **B2**
Hydraulic Gear Pump SAE-A Standard



For more detailed information ask for catalogue HT 15 F 20.....

Hydraulic Remote Servo Controls



For more detailed information ask for catalogue HT 73 B 10.....

Electric and Electronic Remote Servo Controls



For more detailed information ask for catalogue HT 73 B 20.....

Bell Housings and Couplings for Pump Assembly on Gasoline and Diesel Engines

GASOLINE OR DIESEL ENGINES

FLANGES AND COUPLINGS

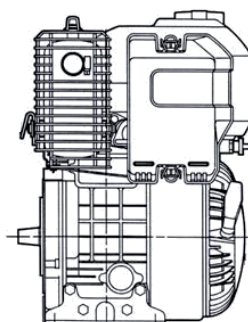
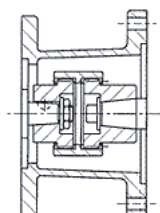

For more detailed information ask our technical departement

As HANSA-TMP has a very extensive range of products and some products have a variety of applications, the information supplied may often only apply to specific situations.

If the catalogue does not supply all the information required, please contact HANSA-TMP.

In order to provide a comprehensive reply to queries we may require specific data regarding the proposed application.

Whilst every reasonable endeavour has been made to ensure accuracy, this publication cannot be considered to represent part of any contract, whether expressed or implied.

The data in this catalogue refer to the standard product. The policy of HANSA-TMP consists of a continuous improvement of its products. It reserves the right to change the specifications of the different products whenever necessary and without giving prior information.



HYDRAULIC COMPONENTS
HYDROSTATIC TRANSMISSIONS
GEARBOXES - ACCESSORIES

Via M. L. King, 6 - **41122 MODENA (ITALY)**
Tel: +39 059 415 711
Fax: +39 059 415 729 / 059 415 730
INTERNET: <http://www.hansatmp.it>
E-MAIL: hansatmp@hansatmp.it