



HYDRAULIC COMPONENTS
HYDROSTATIC TRANSMISSIONS
GEARBOXES - ACCESSORIES

Certified Company ISO 9001 - 14001



Via M. L. King, 6 - 41122 MODENA (ITALY)
Tel: +39 059 415 711
Fax: +39 059 415 729 / 059 415 730
INTERNET: <http://www.hansatmp.it>
E-MAIL: hansatmp@hansatmp.it

HT 16 / M / 159 / 0516 / E

THE PRODUCTION LINE OF HANSA-TMP

Variable Displacement Closed Loop System Axial Piston Compact Tandem Pump

TPV 1200 BTB

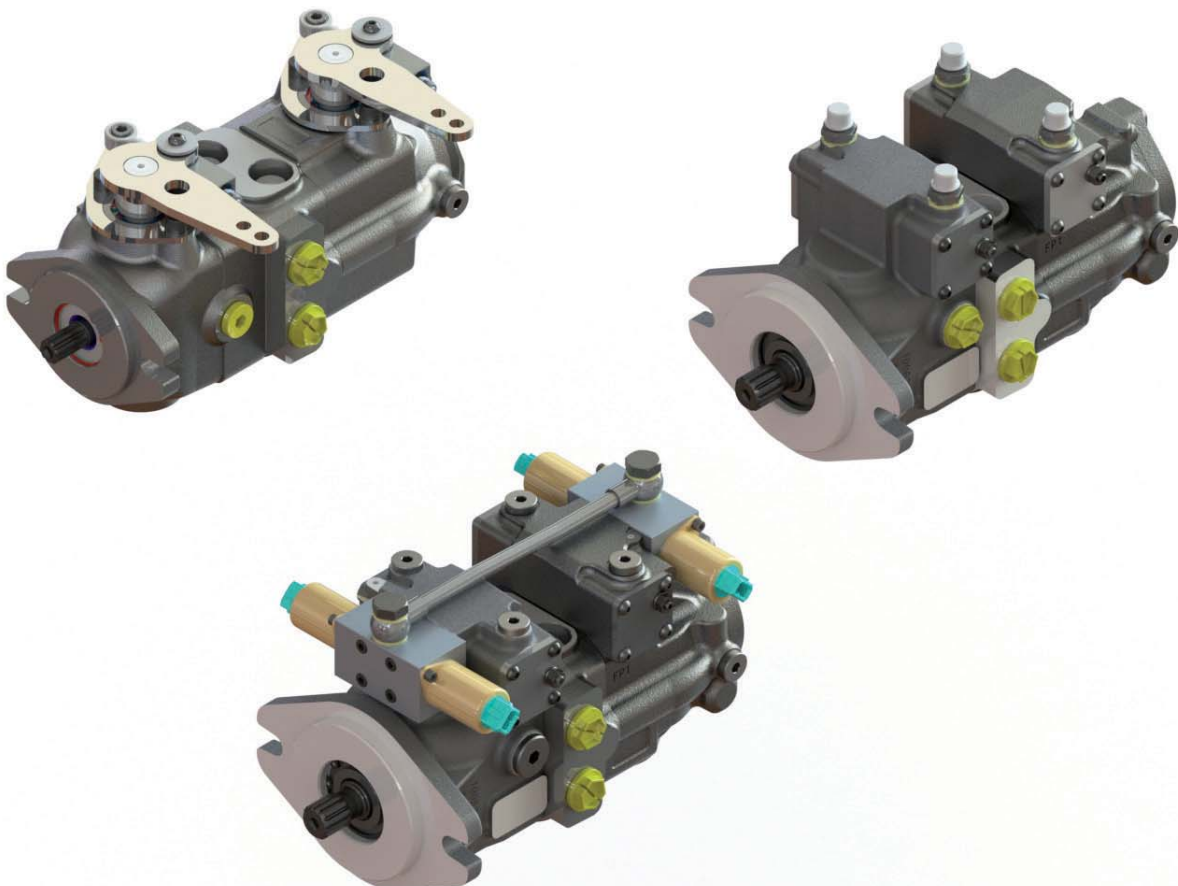

INDEX

General information.....	5
Technical specifications.....	6
System design parameters.....	7
Performance diagram.....	8
Installation instructions.....	9 - 10
Hydraulic fluid.....	11
Hydraulic fluid filtration.....	12
 TPV 1200 BTB	
Order code.....	13 - 15
DM - General dimensions/ports.....	16
SHI - General dimensions/ports.....	17
SEI - General dimensions/ports.....	18
Mounting flanges and shaft.....	19 - 21
DM Direct mechanical control.....	22 - 23
BC Tapered bush.....	24
LC Direct mechanical control with lever.....	25
DMS Control lever with return to zero position (torsion spring).....	26 - 27
DMZ Control lever with return to zero position (compression spring).....	28 - 29
SHI Integrated hydraulic servo control.....	30 - 31
SHIC Compact hydraulic control.....	32 - 33
SEI Electro-proportional servo control.....	34 - 36
Control devices position.....	37
Rear pump mounting flanges.....	38
OPTIONAL FB Adaptor flange SAE A - SAE B.....	39
OPTIONAL ST.....	39
OPTIONAL VS-SB Purge valve with screw by-pass.....	40
OPTIONAL VS-SB1 Purge valve with screw by-pass (180° rotated position).....	41
OPTIONAL SB Screw by-pass	42 - 43
OPTIONAL SB1 Screw by-pass (180° rotated position).....	44 - 45
OPTIONAL MOB Man on board.....	46 - 47
Trouble shooting.....	48
Accessories.....	49
Triple pump.....	50

GENERAL INFORMATION

- TPV 1200 BTB is a variable displacement, compact tandem axial piston pump, with swashplate system, for closed loop hydrostatic transmissions.
- Flow rate is proportional to the rotation speed and displacement, and is continuously variable.
It increases as the swashplate angle moves from "0" to maximum position.
If the swashplate is positioned beyond the neutral point, the flow rate respectively follows one of the two directions.
- The TPV 1200 BTB is equipped with a boost pump, "gerotor" type of new design and high efficiency to keep the circuit pressurised, to compensate the oil leakages of the hydrostatic transmission, to avoid cavitation of the piston pump and to supply low pressure oil flow to the remote controls of the pumps and of the hydraulic transmission (max 3 MPa).
- The standard version is of mechanical type on which, by means of a lever, the change of flow in the two directions is obtained.
- This series of pumps can be with a hydraulic servo control or electro-proportional control which allows the control of the pump by means of hydraulic or electric joysticks.
- Moreover the pump is fitted with relief valves and it is adapted for assembly of auxiliary gear pumps.
- The compact tandem TPV 1200 BTB, are available with splined or parallel shaft and can be supplied with options such as purge valve, screw by-pass valve and, for security, "man on board" valve.
- The piston pumps are to be considered as individual components for the purposes of Directive 98/37/EC, therefore have been built to be integrated into a circuit or to be assembled with other components to form a machine or system. They can be operated only after they have been installed in the machine/system which they are intended for.
- The TPV 1200 BTB pumps must be used to create, manage and regulate oil flow in a closed loop system. Any other use should be considered improper.
- The pumps are built according to the technology normally used for this type of product. There is the risk of injury or damage to personnel during their installation and use if you do not respect the normal safety instructions or if used by untrained personnel.

TECHNICAL SPECIFICATIONS

The housing and the distributor cover of the pumps TPV 1200 are made in cast iron.

The flow rate is proportional to the rotation speed and the displacement is continuously variable. It increases as the swash-plate angle moves from "0" to maximum position.

If the swash-plate is positioned out of the neutral position, the flow respectively follows one of the two directions.

- forest vehicles
- logistic machines

Typical applications

- construction equipment
- green mowers
- zero turn machines
- agricultural machines
- utility vehicles

PUMP MODEL		TPV 6-7	TPV 8-7	TPV 9-7	TPV 11-7	TPV 12-7	TPV 13-7	TPV 15-9	TPV 17-9	TPV 18-9	TPV 19-9	TPV 21-9
Max. displacement	cm ³ /n	7,4	8,9	9,6	11,2	12,8	13,6	15,00	17,1	18,2	19,4	21,15
Flow rating ⁽¹⁾	l/min	25,01	31,96	34,74	40,32	46,08	48,88	54,00	61,77	66,37	69,84	76,4
Power rating ⁽¹⁾	kW	8,75	11,18	12,15	14,11	16,12	17,11	18,9	21,61	23,23	24,44	31,73
Boost pump displacement	cm ³ /n	5,4										
Rated pressure	MPa	21										20
Max. pressure	MPa	30	30	30	30	30	30	28	28	27	25	
Max. relief valve setting	MPa	30						28		27	25	
Standard boost pressure ⁽²⁾	MPa	0,4 (Mechanical Control) 2 (Mechanical / Electric Servo Control)										
Suction pressure	MPa	> = 0,08										
Max. case pressure	MPa	0,15										
Min. inlet shaft speed	n/min	500										
Max speed	n/min	3.600										
Max oil temperature	°C	80										
Oil viscosity	cSt	16-36										
Fluid contamination		19/17/14 ISO 4406 (NAS 8)										
Dry weight ⁽³⁾	kg	17,4										

(1) 3.600 n/min and 21 MPa for single section

(2) 1.000 n/min

(3) Indicative values, weight varies depending on configuration and optionals

SYSTEM DESIGN PARAMETERS

HYDRAULIC MEASURE	USEFUL FORMULAS	CONVERSION FACTORS
Flow rate: Q = (l/min)	$Q = V \text{ [cm}^3/\text{n]} \times \eta_v \times n \times 10^{-3}$	1 l/min = 0,2641 US Gal/min
Pressure: P = (MPa)		1 MPa = 145 PSI
Displacement: V = (cm ³ /n)		
Torque: M = (Nm)	$M = \frac{\Delta p \text{ [MPa]} \times V \text{ [cm}^3/\text{n]}}{6.283 \times \eta_m}$	1 Nm = 8,851 in lbs
Power: P = (kW)	$P = \frac{\Delta p \text{ [MPa]} \times V \text{ [cm}^3/\text{n]} \times n}{60 \times 1000 \times \eta_t}$	1 KW = 1,36 HP
Shaft speed: n = n/min		
Hydraulic efficiency: = η_v		
Mechanical efficiency: = η_m		
Overall efficiency: = η_t		
		1 mm = 0,0394 in
		1 kg = 2,205 lbs
		1 N = 0,2248 lbs

PERFORMANCE DIAGRAM

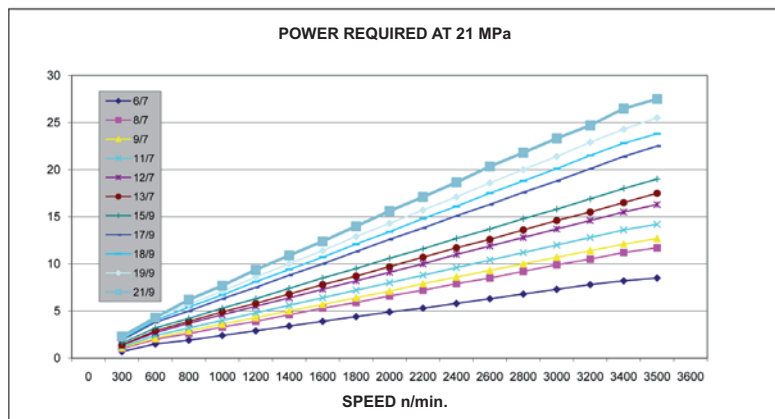
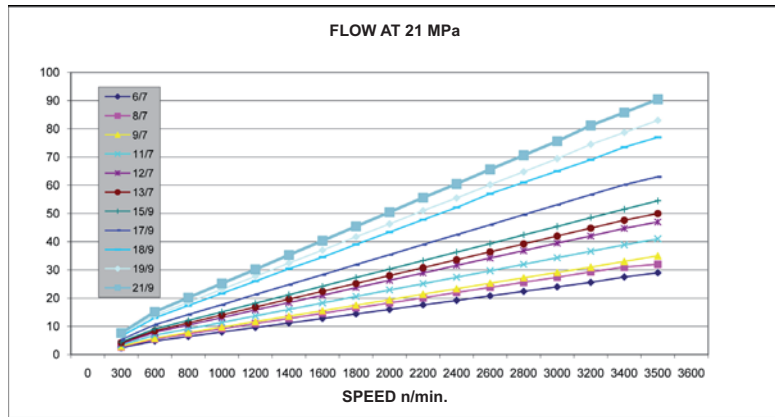

Performance diagrams

- The diagrams show the data of maximum speed and maximum continues pressure.
- Data may vary depending on pump displacement.

Pressure

- Continuous pressure: is the average pressure for continuous work, which must not be exceeded, to ensure a correct and long lasting service of the pump.
- Maximum pressure: is the maximum allowable pressure for short periods and must never be exceeded.

Speed

- Continuous work speed: is the maximum recommended speed for continuous operation of the pump under full load.

- Maximum speed: is the maximum permissible speed for the pump for short periods and not fully loaded. The use of the pump with this speed can reduce the life cause a loss of power or hydrostatic braking capacity.

Caution

Any damage caused to the pump can reduce or eliminate the hydrostatic braking capacity. It is therefore necessary to provide an auxiliary braking system capable of stopping and supporting the weight of the complete machine, in the event of loss of hydrostatic power.

INSTALLATION INSTRUCTIONS

Standards for the installation, start up and maintenance

- When mounting the pump above the minimum level of the tank, distance of the highest point of the pump over the oil level **MUST NOT** exceed 250 mm.
- To reduce the noise level typical of all piston pumps we recommend:
 - use hoses instead of pipes
 - limit to a minimum the length of eventual pipes
 - fix rigid pipe sections with special supports equipped with rubber vibration dampening devices
 - use pipes and hoses with a diameter according to the speed values below:

Suction line = $0,6 \div 1,2$ m / s

Drain = $1,5 \div 3,6$ m / s

Pressurized lines = max 6 m / s

- To calculate the speed of the oil in the lines refer to the formula below:

$$V = Q * 21,22 / D$$

V = speed (m/s)

Q = flow rate (l/min)

D = internal pipe/hose diameter (mm)

- In any case **NEVER** use pipes/hoses or fittings with diameter smaller than that of the corresponding ports on the pump. This indication is **ABSOLUTELY OBLIGATORY** for the drain line to avoid to pressurize the pump housing and extrude the lip seal of the pump shaft.
- During mounting cure the alignment of the pump, concentric with the drive shaft sleeve to prevent overloading of the bearing.
- For the hydraulic system, we recommend using pipes/hoses washed internally with hydraulic oil or, even better, with solvent.
- Special care must be taken when cleaning the inside of the tank (painting is recommended after sand blasting).
- To improve the functionality of the boost pump, it is recommended to place it below minimum tank level.
- The pumps can be installed in any direction and position.
For further information contact our Technical Department.

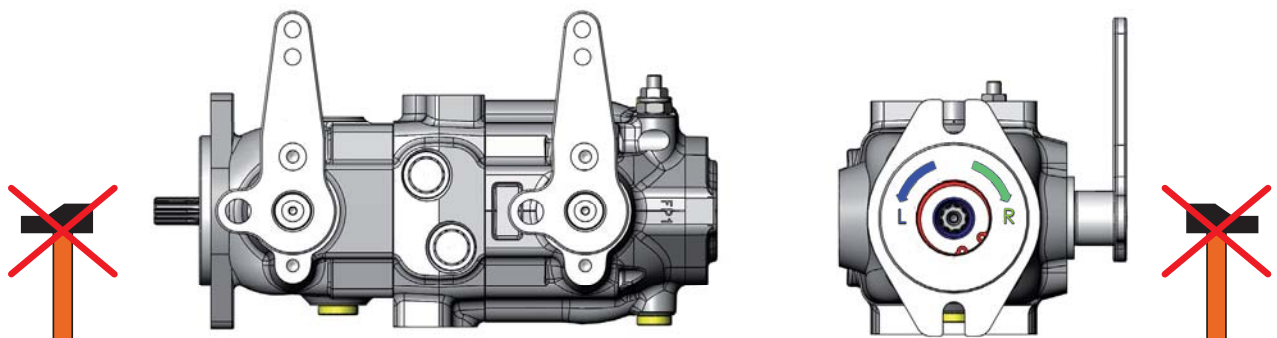

(continued)

INSTALLATION INSTRUCTIONS

Shaft Coupling

To connect the pump shaft to the engine flywheel or prime motor shaft use a flexible

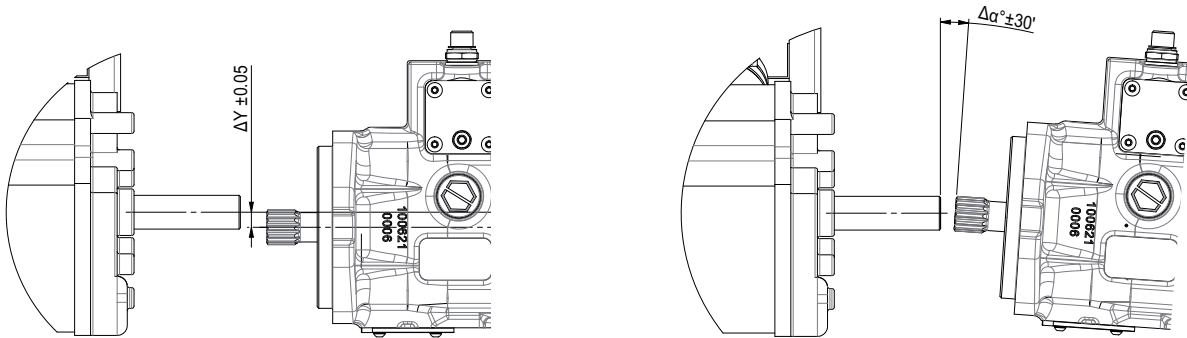

coupling. The alignment must be within the tolerances indicated in the figures below. For an optimal function of the pump the shaft should not be subjected to radial or axial loads. In the presence of radial and axial loads the maximum allowable values are shown below.

During the installation or removal, do not force the coupling of the pump shaft, but always use the threaded hole on the shaft.

Start up

- Before starting fill the tank and the other components with new filtered oil. You should run a flushing of the complete hydraulic system (see Use and Maintenance Manual). Check that the low pressure value is correct (refer to the Use and Maintenance Manual).
- Restore the oil level in the tank.

Maintenance

- The first oil change should be made after 500 hours of operation. Later change the oil every 2000 hours.
- The first replacement of the filter cartridge has to be made after 50 hours for a preliminary circuit cleaning. Then after further 500 hours.

- These frequencies have to be reduced in the case where the indicator shows the clogging of the filter cartridge and in case of operation in environments with a high level of contamination.

CAUTION

- Always work with the utmost attention to the moving parts; do not use loose or fluttering clothing.
- Do not approach rotating wheels, tracks, chains or shafts if not properly protected, or when they may start moving without notice.
- Do not loosen or disconnect fittings and pipes/hoses while the engine is running.
- Avoid oil leaks in order to prevent environmental pollution.

Load capacity of rear shaft (through drive shaft)

- The rear shaft is not able to carry radial loads.

HYDRAULIC FLUID

Viscosity

The maximum duration and the maximum efficiency are related to the optimum range of viscosity.

Viscosity = optimal operating viscosity 15 ÷ 40 cSt referred to the temperature of the closed circuit.

Minimum viscosity = 10 cSt for short moments and with the maximum temperature of the drain oil at 90 °C.

Max. viscosity = 1000 cSt for a few seconds, only during cold starting.

Working conditions

For working conditions apply the following limits:

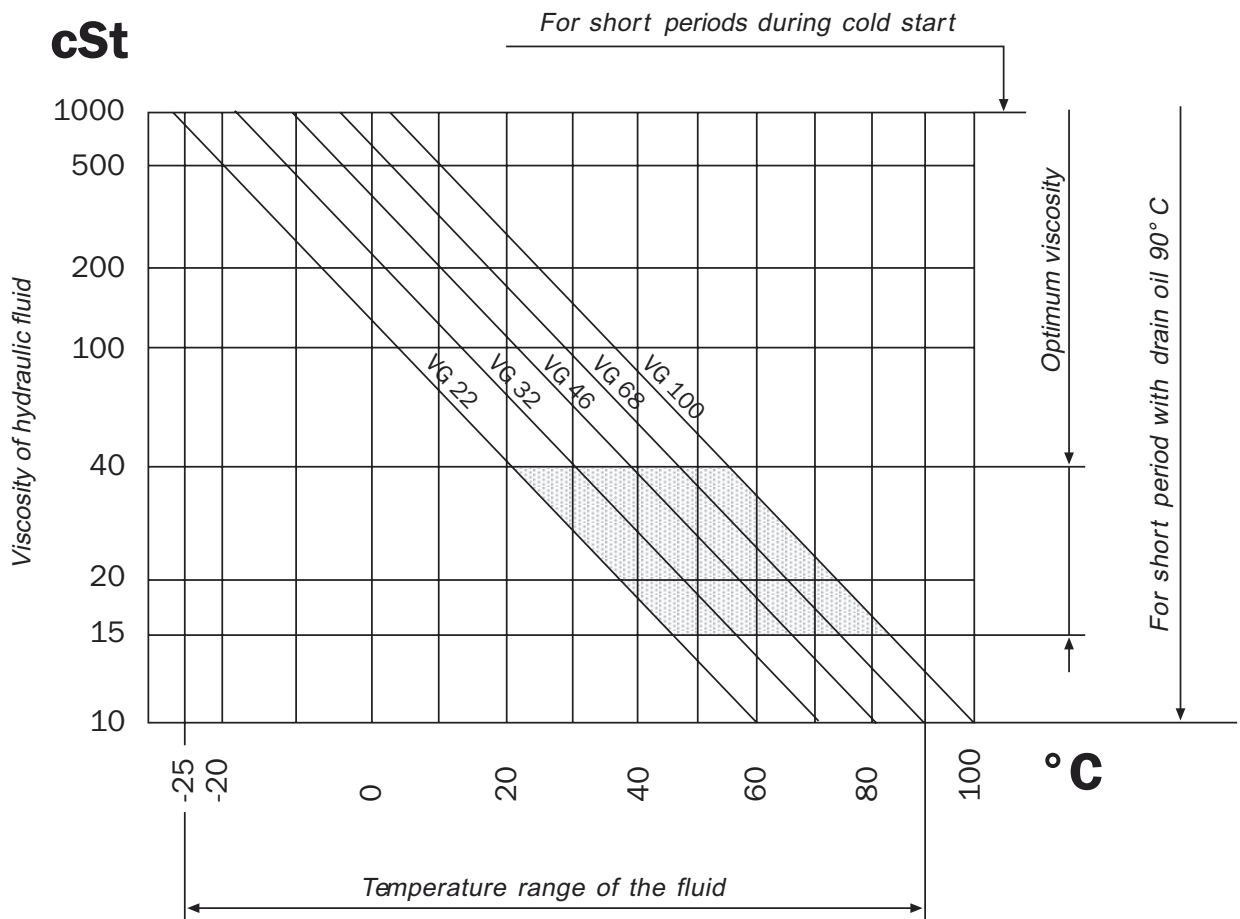

HANSA - TMP cannot be held responsible concerning non compliance of these instructions and observance of safety regulations, although not covered by this document.

HYDRAULIC FLUID FILTRATION

The contaminating particles suspended in the hydraulic fluid cause the wear of the hydraulic mechanisms moving parts.

On hydraulic pumps these parts operate with very small dimensional tolerances.

In order to prolong the parts life, it is recommended to use a filter that maintains the hydraulic fluid contamination class at max.

8 according to NAS 1638

5 according to SAE, ASTM, AIA

19/17/14 according to ISO 4406

According to the type of application decided for the pump, it is necessary to use filtration elements with a filtration ratio of:

$$\beta_{(x)} 20 \div 30 \geq 75$$

making sure that this ratio does not worsen together with the increasing of the filter cartridge differential pressure. While the pump is working, its temperature increases (over 80° to 110°C) with negative effects on pump performances; as a consequence, it is important to observe a max. contamination level of:

7 according to NAS 1638

4 according to SAE, ASTM, AIA

18/16/13 according to ISO 4406

If these values cannot be secured, the component life will consequently be reduced and it is recommended to contact our Tech. Dept.

Suction filters

The suction filters will have a clogging indicator and bypass. The max. pressure drop of the filtration element must not exceed 0,04 absolute MPa (0,08 absolute MPa with cold start).

Filter assembling

The suction filter is mounted in the suction line. Check that the pressure before the boost pump is 0,8 absolute bar, measured on the pump suction port (0,05 MPa for cold starting).

ORDER CODE _____

1200	TPV-T	6-7	6-7	CR	SS2	F1	DM	DM	OA	OA	30	30	06	C	000	00
0	1	2	3	4	5	6	7	8	9	10	11	12	13	14	15	16

Pag.

1200	0 - Pump series = TPV pump 1200	
TPV-T TPV-T-T3	1 - Pump model = Closed loop circuit tandem pump = Closed loop circuit triple pump	
	2 - Primary pump displacement	
	6-7 = 7,4 cm ³ /n 8-7 = 8,9 cm ³ /n 9-7 = 9,6 cm ³ /n 11-7 = 11,2 cm ³ /n	
	12-7 = 12,8 cm ³ /n 13-7 = 13,6 cm ³ /n 15-9 = 15 cm ³ /n 17-9 = 17,1 cm ³ /n	
	18-9 = 18,2 cm ³ /n 19-9 = 19,4 cm ³ /n 21-9 = 21,15 cm ³ /n	
	3 - Secondary pump displacement	
	6-7 = 7,4 cm ³ /n 8-7 = 8,9 cm ³ /n 9-7 = 9,6 cm ³ /n 11-7 = 11,2 cm ³ /n	
	12-7 = 12,8 cm ³ /n 13-7 = 13,6 cm ³ /n 15-9 = 15 cm ³ /n 17-9 = 17,1 cm ³ /n	
	18-9 = 18,2 cm ³ /n 19-9 = 19,4 cm ³ /n 21-9 = 21,15 cm ³ /n	
CR CC	4 - Rotation = Clockwise rotation (right) = Counter-clockwise rotation (left)	
SS2 PS3 SS3 SS4	5 - Shaft (mounting side) = Splined shaft Z 9 - 16/32 D.P. = Parallel keyed shaft 18 mm. diam. with increased bearing for external radial load = Splined shaft Z 13 - 16/32 D.P. (available only with servo-control SHI, SEI and SAE B flange) = Splined shaft Z 11 - 16/32 D.P.	19 19 20 20
F1 F2.1	6 - Mounting flange = SAE-A 2 holes - pilot diam. 82,5 mm. = SAE-B 2 holes - pilot diam. 101,6 mm. (available only with servo-control SHI, SEI and shaft SS3)	21 21
DM BC LC DMS DMS (30) DMS (33) DMS (40) DMS (50) DMZB DMZR DMZV SHI SHIC SEI1.3 SEI2.3	7 - Primary pump controls = Direct mechanical (without control lever) = Tapered bush = Direct Mechanical Control with Lever = Control lever with return to zero position (torsion spring standard diameter 3,6 mm.) = Control lever with return to zero position (torsion spring diameter 3 mm.) = Control lever with return to zero position (torsion spring diameter 3,3 mm.) = Control lever with return to zero position (torsion spring diameter 4 mm.) = Control lever with return to zero position (torsion spring diameter 5 mm.) = Control lever with return to zero position (blue compression spring standard) = Control lever with return to zero position (red compression spring) = Control lever with return to zero position (green compression spring) = Integrated hydraulic servo control = Integrated hydraulic servo control (compact version) = Integrated electro-proportional servo control 12V DC = Integrated electro-proportional servo control 24V DC	22 24 25 26 26 26 26 26 28 28 28 30 32 34 34

(continued)

ORDER CODE _____

8 - Secondary pump controls		
DM	= Direct mechanical (without control lever)	22
BC	= Tapered bush	24
LC	= Direct Mechanical Control with Lever	25
DMS	= Control lever with return spring (torsion spring standard diameter 3,6 mm.)	26
DMS (30)	= Control lever with return spring (torsion spring diameter 3 mm.)	26
DMS (33)	= Control lever with return spring (torsion spring diameter 3,3 mm.)	26
DMS (40)	= Control lever with return spring (torsion spring diameter 4 mm.)	26
DMS (50)	= Control lever with return spring (torsion spring diameter 5 mm.)	26
DMZB	= Control lever with return spring (blue compression spring standard)	28
DMZR	= Control lever with return spring (red compression spring)	28
DMZV	= Control lever with return spring (green compression spring)	28
SHI	= Integrated hydraulic servo control	30
SHIC	= Integrated hydraulic servo control (compact version)	32
SEI1.3	= Integrated electro-proportional servo control 12V DC	34
SEI2.3	= Integrated electro-proportional servo control 24V DC	34

9 - Primary pump control devices position		
OA	= Position A (mechanical without lever or servo control)	37
OB	= Position B (mechanical without lever or servo control)	37
LA	= Position A - Lever to left	37
RA	= Position A - Lever to right	37
LB	= Position B - Lever to left	37
RB	= Position B - Lever to right	37

10 - Secondary pump control devices position		
OA	= Position A (mechanical without lever or servo control)	37
OB	= Position B (mechanical without lever or servo control)	37
LA	= Position A - Lever to left	37
RA	= Position A - Lever to right	37
LB	= Position B - Lever to left	37
RB	= Position B - Lever to right	37

11 - Primary pump relief valve pressure setting *			
	10 = 10 MPa	15 = 15 MPa	18 = 18 MPa
	20 = 20 MPa	25 = 25 MPa	30 = 30 MPa

12 - Secondary pump relief valve pressure setting *			
	10 = 10 MPa	15 = 15 MPa	18 = 18 MPa
	20 = 20 MPa	25 = 25 MPa	30 = 30 MPa

* The rated pressure value are changing with different speed.

13 - Boost pump		
00	= Without boost pump	
06	= Standard pump (5,4 cm ³ /n) Standard setting: 4 bar (mechanical control) or 20 bar (hydraulic / electric servo control) at 1000 n/min.	
06(xx)	= Other pressure settings on request (between 0,4 and 3 MPa, contact our Technical Department).	

14 - Auxiliary rear pump mounting flange option		
C	= Closed cover (without rear fitting)	38
B1	= German standard pump group 1 mounting	38
B2	= German standard pump group 2 mounting	38

(continued)

ORDER CODE _____

000 **15 - Auxiliary gear pump displacements ****
= Without pump

Group 1

109 = 0,9 cm ³ /n	112 = 1,2 cm ³ /n	117 = 1,7 cm ³ /n	122 = 2,1 cm ³ /n
126 = 2,6 cm ³ /n	132 = 3,1 cm ³ /n	138 = 3,6 cm ³ /n	143 = 4,2 cm ³ /n
149 = 4,9 cm ³ /n	159 = 5,9 cm ³ /n	165 = 6,5 cm ³ /n	178 = 7,5 cm ³ /n
198 = 9,8 cm ³ /n			

Group 2

204 = 4,2 cm ³ /n	206 = 6,0 cm ³ /n	209 = 8,4 cm ³ /n	211 = 10,8 cm ³ /n
214 = 14,4 cm ³ /n	217 = 16,8 cm ³ /n	219 = 19,2 cm ³ /n	222 = 22,8 cm ³ /n
226 = 26,2 cm ³ /n			

** Also available multiple gear pumps (for instance: 204+117).

16 - Optional

00	= Without optional	
V	= Viton seals	
FB	= Conversion flange from SAE A to SAE B	39
ST	= Conversion sleeve adapter 9 teeth to 13 teeth - 16/32 D.P.	39
FBST	= Conversion flange from SAE A to SAE B + Sleeve 9 teeth to 13 teeth - 16/32 D.P.	39
VS-SB	= Purge valve with screw by-pass (standard position)	40
VS-SB1	= Purge valve with screw by-pass (180° rotated position)	41
SB	= Screw by-pass (standard position)	42
SB1	= Screw by-pass (180° rotated position)	44
MOB1	= Man on board solenoid valve 12V DC (only for servo versions)	46
MOB2	= Man on board solenoid valve 24V DC (only for servo versions)	46
G/J/M/-	= Port threads and restrictor diameter	

	Servo control type	Port threads	Symbol
STANDARD	SEI	Plugged	-
	SHI	1/4" BSPP	G
ON REQUEST	SHI	JIC (7/16" - 20)	J
	SHI	METRIC (M12x1,5)	M

Restrictor diameter (SHI/SEI)	
-	Without restrictor
06	Restrictor orifice ø 0,6 mm
08	Restrictor orifice ø 0,8 mm
10	Restrictor orifice ø 1,0 mm
12	Restrictor orifice ø 1,2 mm
16	Restrictor orifice ø 1,6 mm
20	Restrictor orifice ø 2,0 mm

Example G/08 = 1/4" BSPP port threads and Ø 0,8 mm restrictor (SHI)

Example -/08 = Ø 0,8 mm restrictor (SEI)

DM

GENERAL DIMENSIONS/PORTS

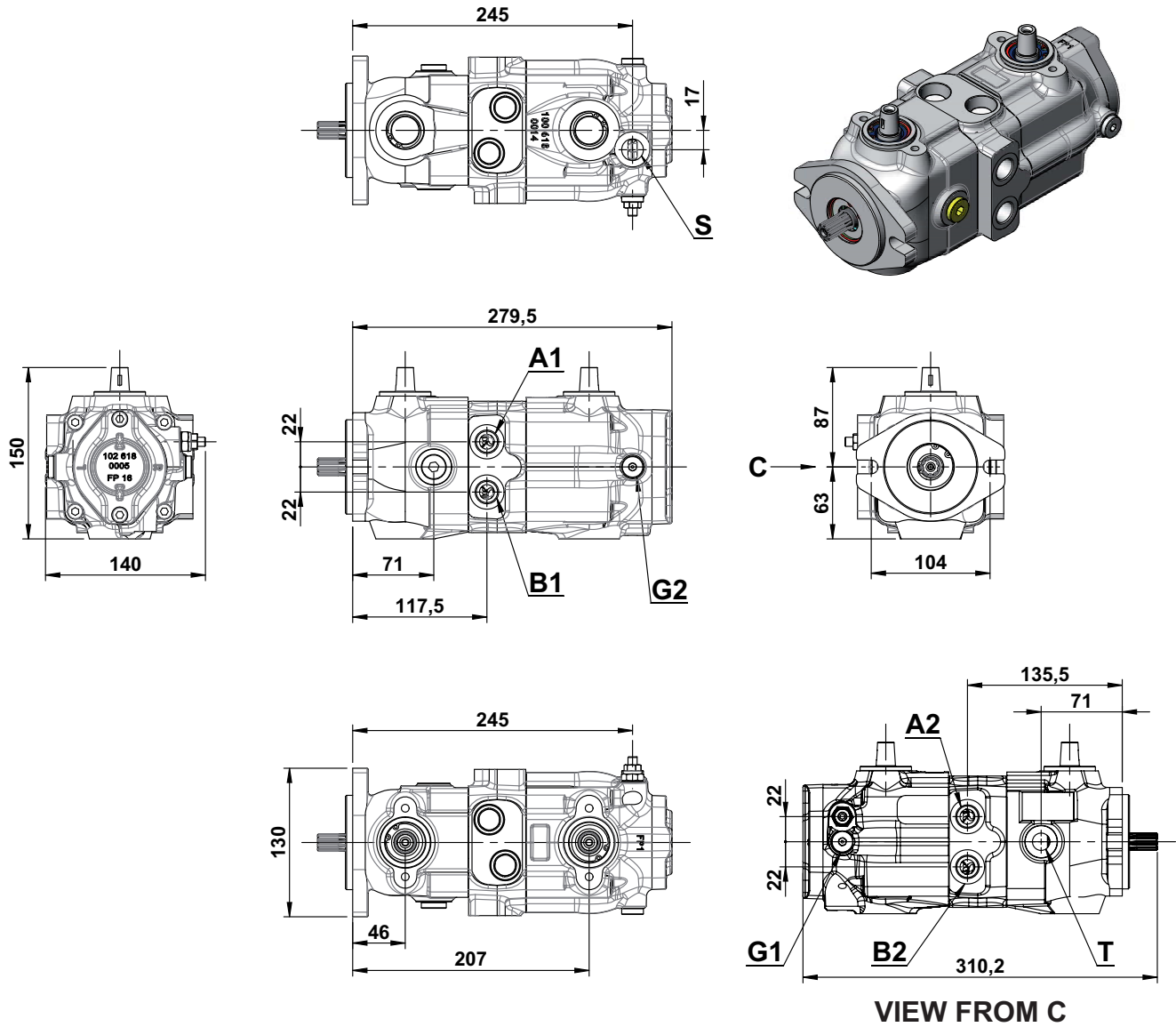

PIPES CONNECTION		
REFERENCE	DESCRIPTION	F1 - SAE A
A1 - B1	Main ports pump 1	1/2" BSPP
A2 - B2	Main ports pump 2	1/2" BSPP
T	Drain	3/8" BSPP
S	Suction	1/2" BSPP
G1 - G2	Boost pump pressure gauge ports	1/4" BSPP



SHI

GENERAL DIMENSIONS/PORTS

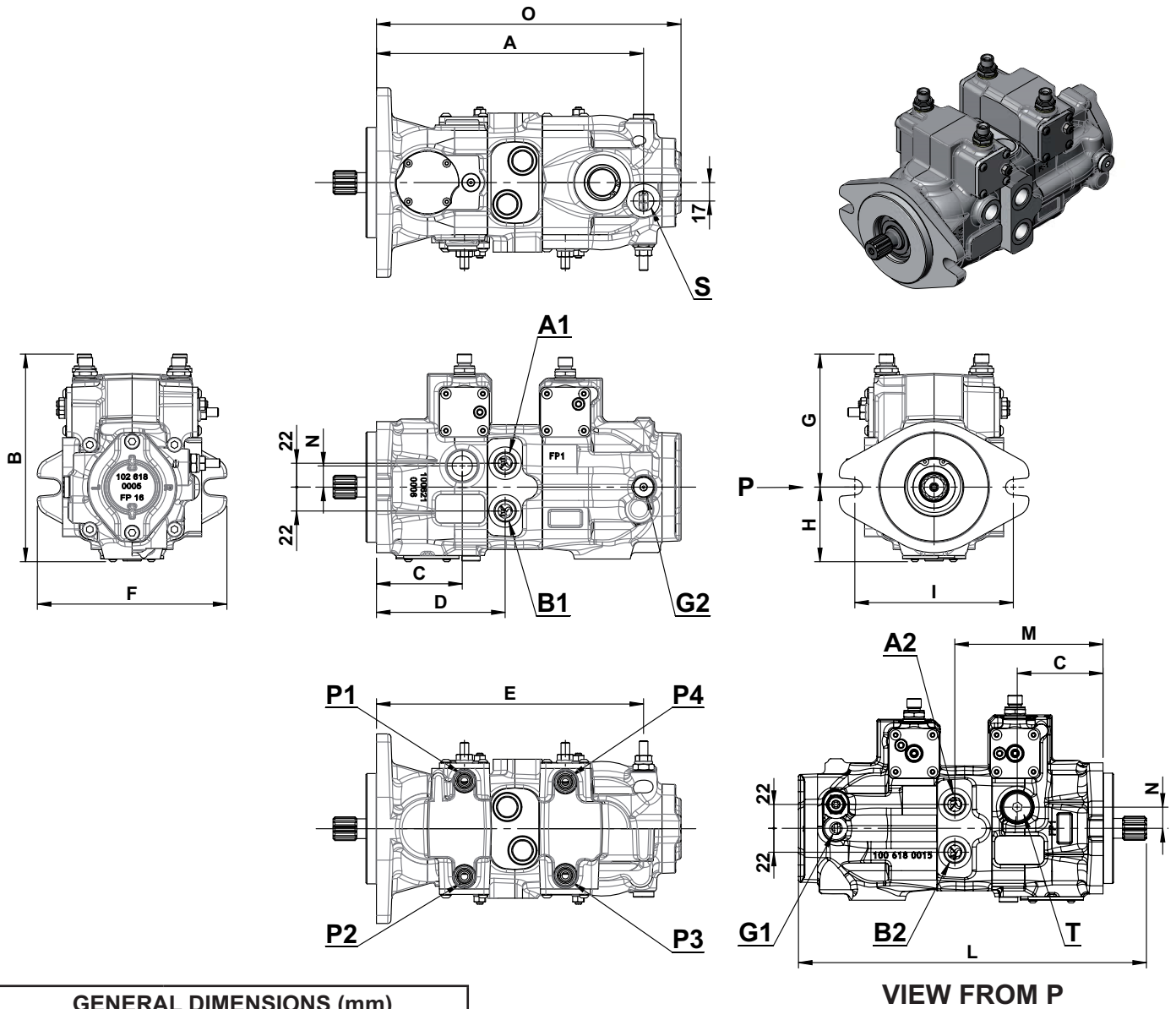

GENERAL DIMENSIONS (mm)		
REFERENCE	F1 - SAE A	F2.1 - SAE B
A	245	246
B	186,2	191,2
C	78	79
D	117,5	118,5
E	245	246
F	130	174,6
G	120	122,5
H	66,2	68,7
I	104	146
L	310,2	320,5
M	135,5	136,5
N	0	19,5
O	279,5	280,5

PIPES CONNECTION			
REFERENCE	DESCRIPTION	F1 - SAE A	F2.1 - SAE B
A1 - B1	Main ports pump 1	1/2" BSPP	1/2" BSPP
A2 - B2	Main ports pump 2	1/2" BSPP	1/2" BSPP
T1 - T2	Drain	3/8" BSPP	1/2" BSPP
S	Suction	1/2" BSPP	1/2" BSPP
G1 - G2	Boost pump pressure gauge ports	1/4" BSPP	1/4" BSPP
P1 - P2	Pilot pressure pump 1	1/4" BSPP	1/4" BSPP
P3 - P4	Pilot pressure pump 2	1/4" BSPP	1/4" BSPP



SEI

GENERAL DIMENSIONS/PORTS

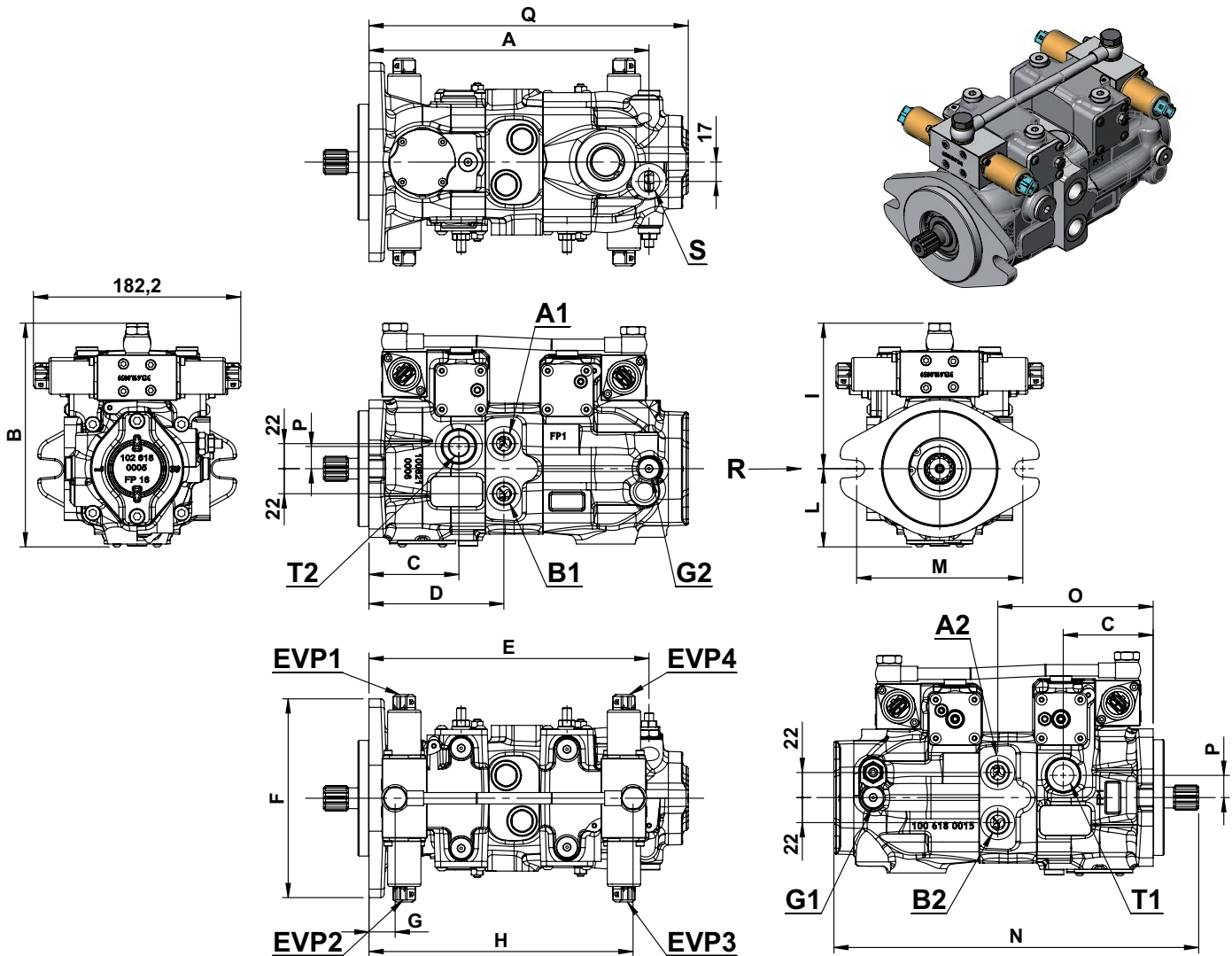

VIEW FROM R

GENERAL DIMENSIONS (mm)		
REFERENCE	F1 - SAE A	F2.1 - SAE B
A	245	246
B	192,5	196,5
C	78	79
D	117,5	118,5
E	245	246
F	130	174,6
G	22	23
H	231	232
I	126,3	127,8
L	66,2	68,7
M	104	146
N	310,2	320,5
O	135,5	136,5
P	0	19,5
Q	279,5	280,5

PIPES CONNECTION			
REFERENCE	DESCRIPTION	F1 - SAE A	F2.1 - SAE B
A1 - B1	Main ports pump 1	1/2" BSPP	1/2" BSPP
A2 - B2	Main ports pump 2	1/2" BSPP	1/2" BSPP
T1 - T2	Drain	3/8" BSPP	1/2" BSPP
S	Suction	1/2" BSPP	1/2" BSPP
G1 - G2	Boost pump pressure gauge ports	1/4" BSPP	1/4" BSPP
EVP1 - EVP2	Pilot pressure pump 1	1/4" BSPP	1/4" BSPP
EVP3 - EVP4	Pilot pressure pump 2	1/4" BSPP	1/4" BSPP

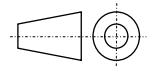

MOUNTING FLANGES AND SHAFT

PS3

PARALLEL KEYED SHAFT

18 mm. Diam.

Max. torque = 85 Nm

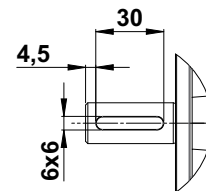
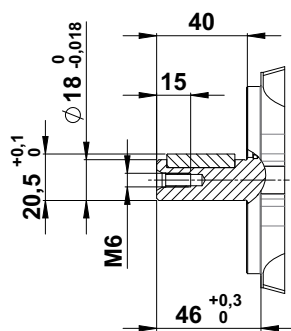

SS2

SPLINED SHAFT Z = 9

Max. torque = 120 Nm

Z9 16/32 D.P.
SPLINED

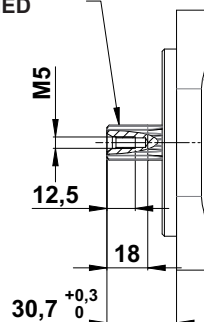

(continued)

MOUNTING FLANGES AND SHAFT

SS3

SPLINED SHAFT Z = 13

(Available only with servo-control SHI, SEI and SAE B flange)

Max. torque = 320 Nm

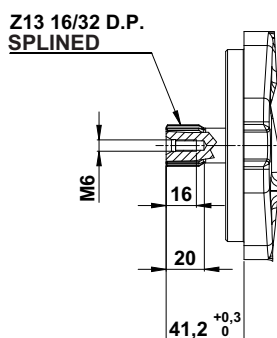

SS4

SPLINED SHAFT Z = 11

Max. torque = 160 Nm

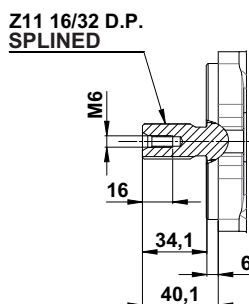

Attention: for the application of multiple pumps the total absorbed torque must not exceed the indicated value.



(continued)

MOUNTING FLANGES AND SHAFT

F1

SAE A - 2 HOLES FLANGE

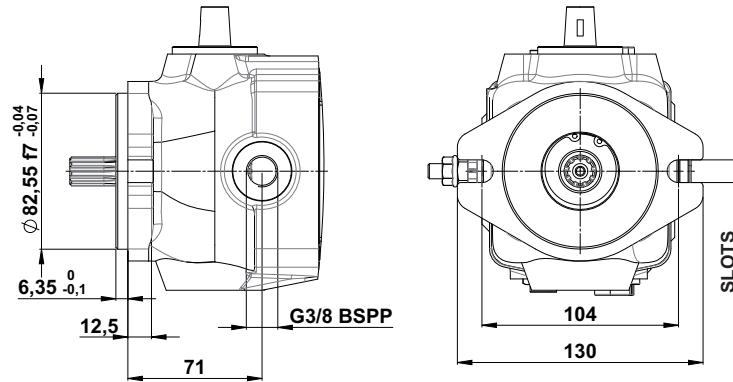

F2.1

SAE B - 2 HOLES FLANGE

(Available only with servo-control SHI, SEI and shaft SS3)

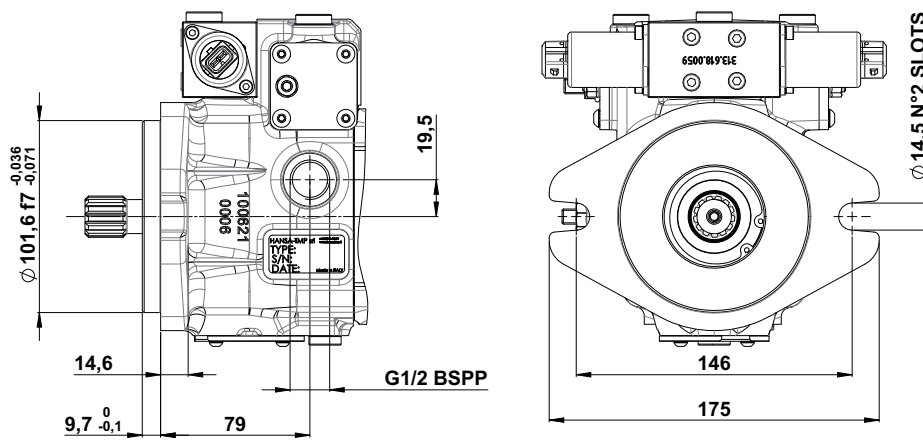

DM

DIRECT MECHANICAL CONTROL

The change of pump displacement is given by clockwise or counter clockwise rotation of the drive pin of the oscillating plate.

The drive pin is directly linked with the oscillating plate.

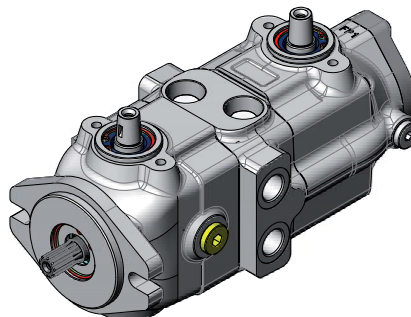
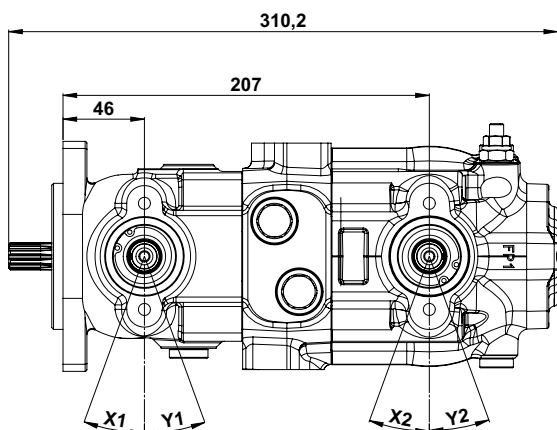
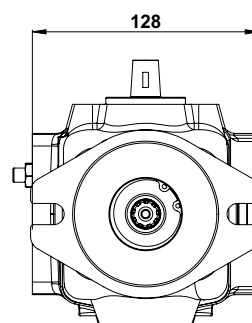
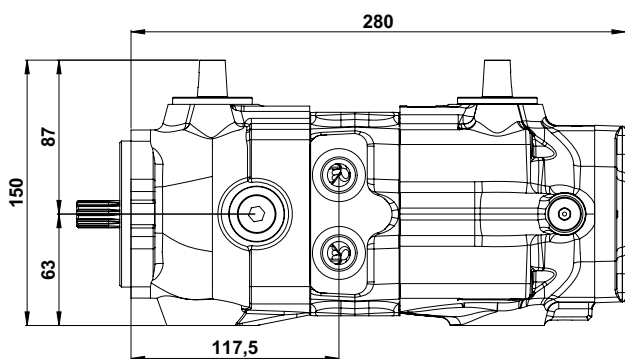

LEVER ANGLE											
Pump Model	6/7	8/7	9/7	11/7	12/7	13/7	15/9	17/9	18/9	19/9	21/9
Lever Angle (X - Y)	10°	12°	13°	15°	17°	18°	15°	17°	18°	19°	19°



(continued)

DM

DIRECT MECHANICAL CONTROL

HYDRAULIC DIAGRAM

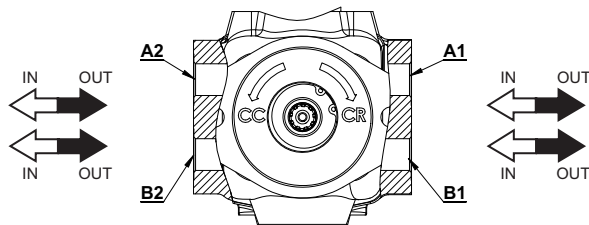
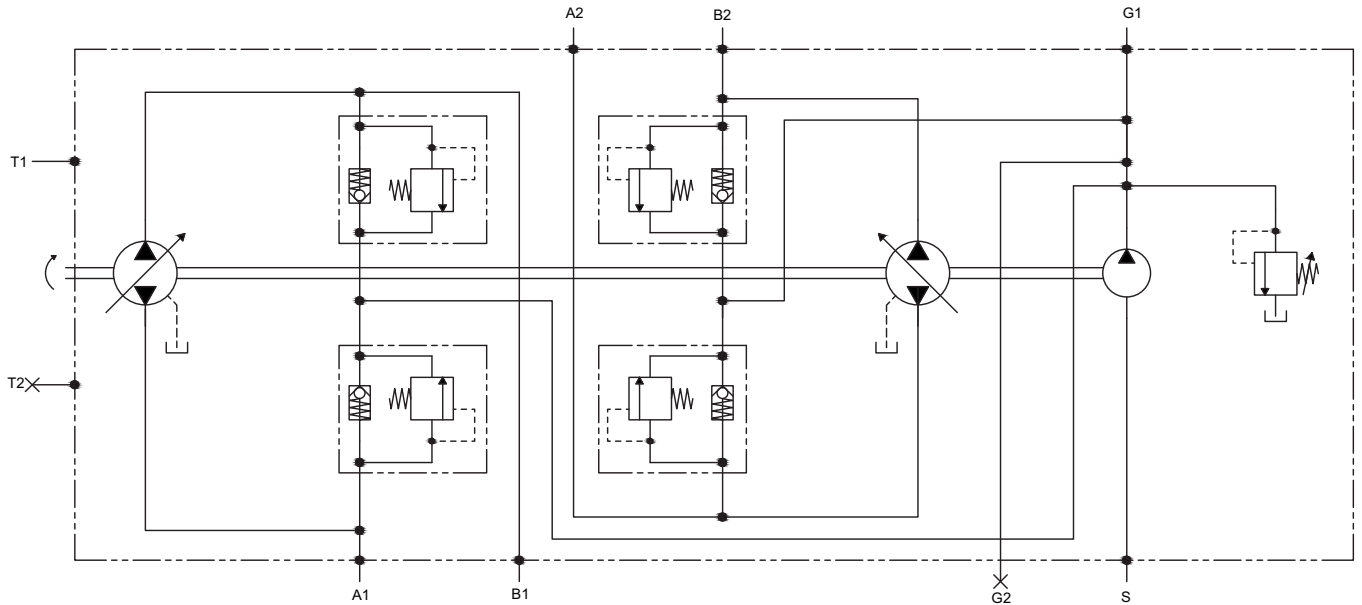

FLOW DIRECTION	PRIMARY PUMP			SECONDARY PUMP		
	Lever position	OUT	IN	Lever position	OUT	IN
Clockwise (CR)	X ₁	B ₁	A ₁	X ₂	A ₂	B ₂
	Y ₁	A ₁	B ₁	Y ₂	B ₂	A ₂
Counter clockwise (CC)	X ₁	A ₁	B ₁	X ₂	B ₂	A ₂
	Y ₁	B ₁	A ₁	Y ₂	A ₂	B ₂

BC

TAPERED BUSH

Tapered bush with woodruff key, external cylindrical. Suitable for arrangement of specific control lever.

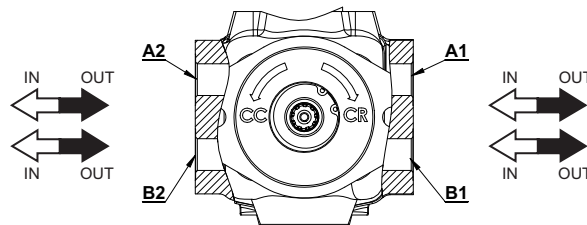
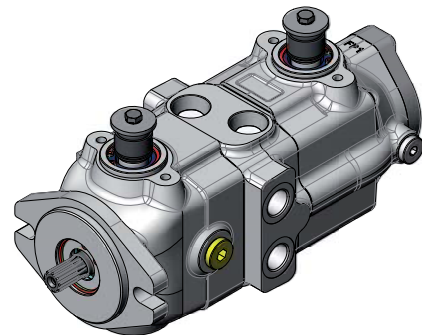
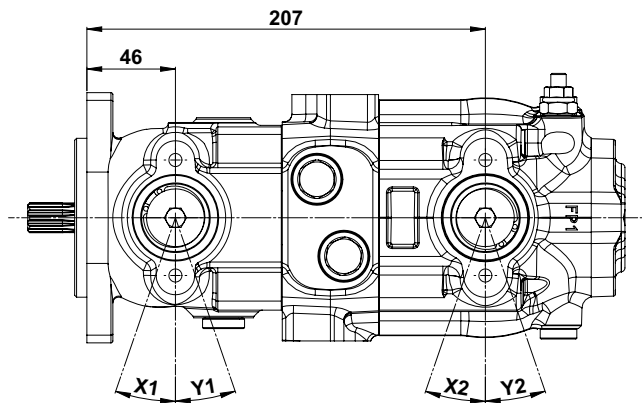
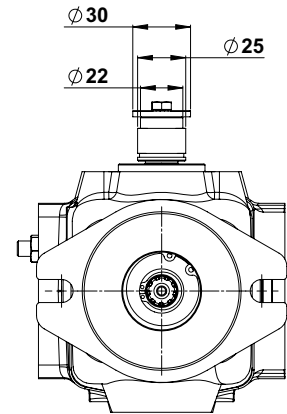
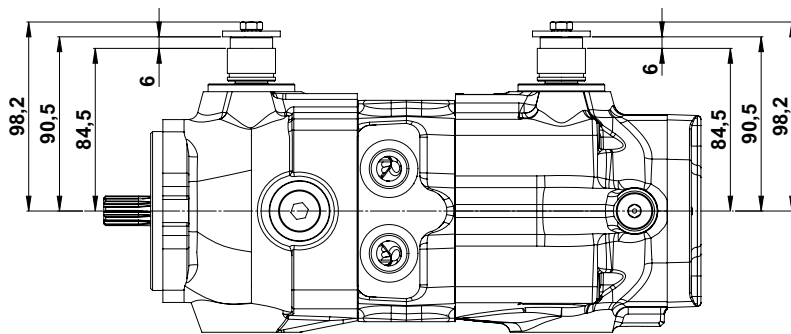

FLOW DIRECTION	PRIMARY PUMP			SECONDARY PUMP		
	Lever position	OUT	IN	Lever position	OUT	IN
Clockwise (CR)	X ₁	B ₁	A ₁	X ₂	A ₂	B ₂
	Y ₁	A ₁	B ₁	Y ₂	B ₂	A ₂
Counter clockwise (CC)	X ₁	A ₁	B ₁	X ₂	B ₂	A ₂
	Y ₁	B ₁	A ₁	Y ₂	A ₂	B ₂



LC

DIRECT MECHANICAL CONTROL WITH LEVER

The pump displacement variation is obtained by rotating the lever in a clockwise or counter-clockwise direction.

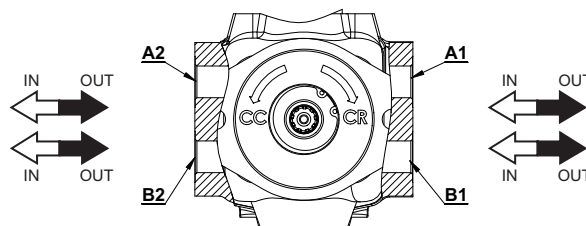
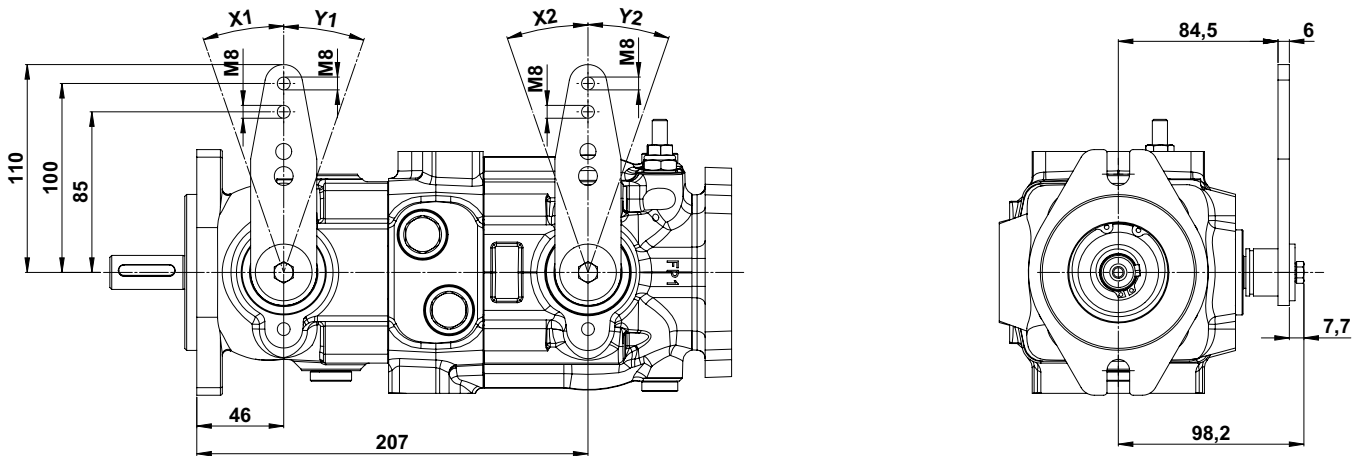
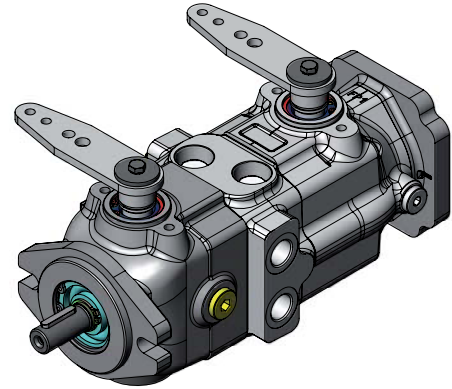

FLOW DIRECTION	PRIMARY PUMP			SECONDARY PUMP		
	Lever position	OUT	IN	Lever position	OUT	IN
Clockwise (CR)	X ₁	B ₁	A ₁	X ₂	A ₂	B ₂
	Y ₁	A ₁	B ₁	Y ₂	B ₂	A ₂
Counter clockwise (CC)	X ₁	A ₁	B ₁	X ₂	B ₂	A ₂
	Y ₁	B ₁	A ₁	Y ₂	A ₂	B ₂



DMS

CONTROL LEVER WITH RETURN TO ZERO POSITION

(torsion spring)

The pump displacement variation is obtained by rotating the lever in a clockwise or counter-clockwise direction.

Return to zero is obtained through a spring integrated in the lever shaft.

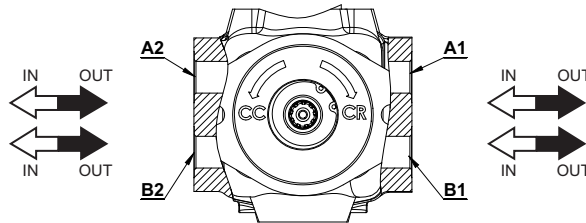
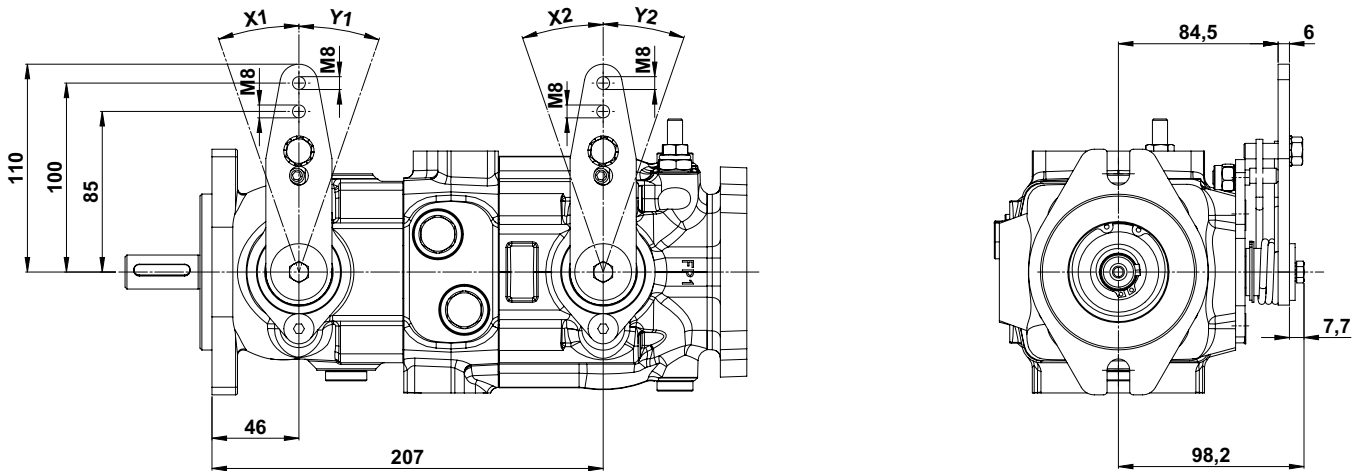
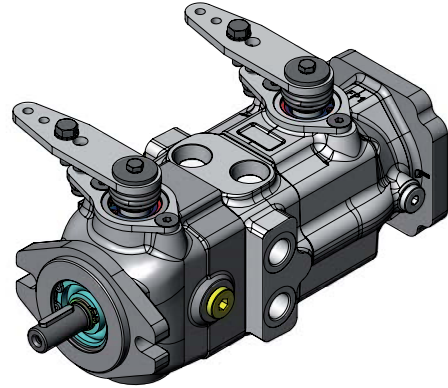

FLOW DIRECTION	PRIMARY PUMP			SECONDARY PUMP		
	Lever position	OUT	IN	Lever position	OUT	IN
Clockwise (CR)	X ₁	B ₁	A ₁	X ₂	A ₂	B ₂
	Y ₁	A ₁	B ₁	Y ₂	B ₂	A ₂
Counter clockwise (CC)	X ₁	A ₁	B ₁	X ₂	B ₂	A ₂
	Y ₁	B ₁	A ₁	Y ₂	A ₂	B ₂

LEVER ANGLE											
Pump Model	6/7	8/7	9/7	11/7	12/7	13/7	15/9	17/9	18/9	19/9	21/9
Lever Angle (X - Y)	10°	12°	13°	15°	17°	18°	15°	17°	18°	19°	19°



(continued)

DMS

CONTROL LEVER WITH RETURN TO ZERO POSITION

(torsion spring)

Standard spring diameter: 3,6 mm

Other available diameters: 3 - 3,3 - 4 - 5 mm

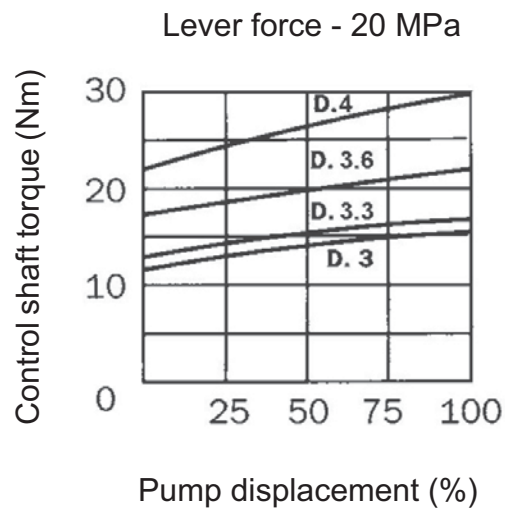
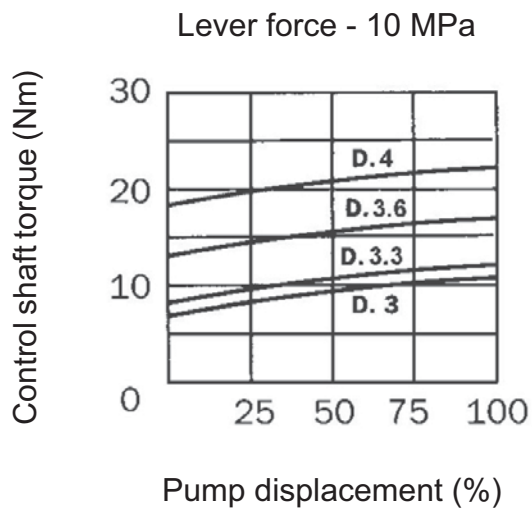

DMZ

CONTROL LEVER WITH RETURN TO ZERO POSITION

(compression spring)

The pump displacement variation is obtained by rotating the lever in a clockwise or counter-clockwise direction.

Return to zero is obtained trough a spring integrated in the lever shaft.

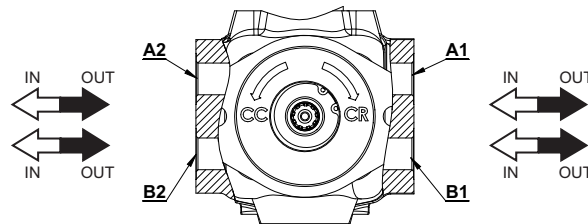
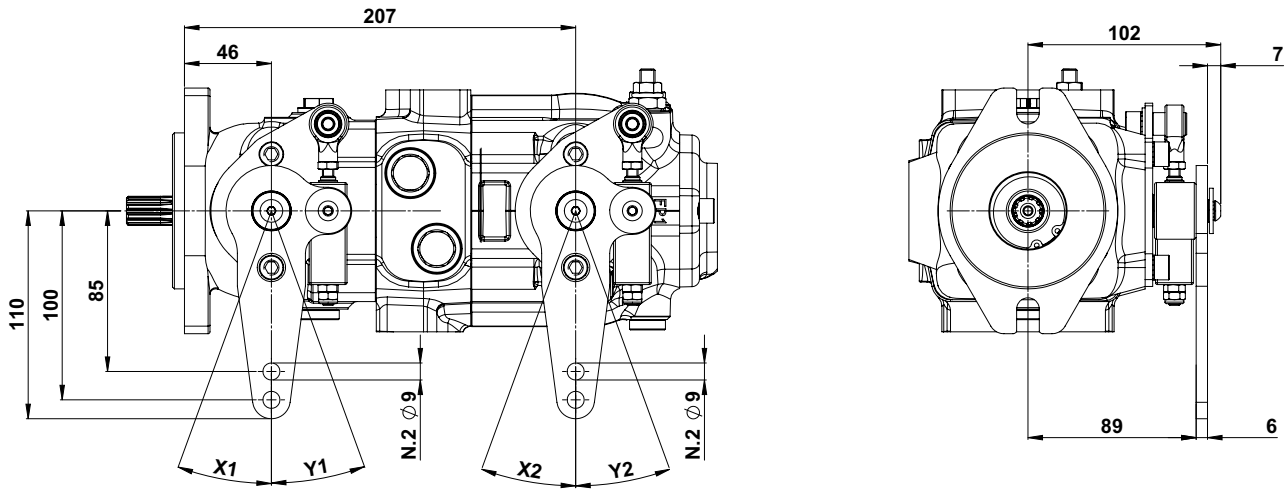
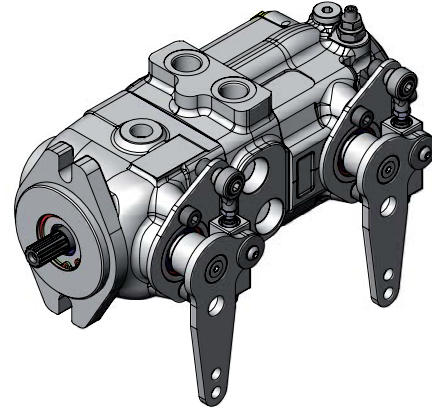

FLOW DIRECTION	PRIMARY PUMP			SECONDARY PUMP		
	Lever position	OUT	IN	Lever position	OUT	IN
Clockwise (CR)	X ₁	B ₁	A ₁	X ₂	A ₂	B ₂
	Y ₁	A ₁	B ₁	Y ₂	B ₂	A ₂
Counter clockwise (CC)	X ₁	A ₁	B ₁	X ₂	B ₂	A ₂
	Y ₁	B ₁	A ₁	Y ₂	A ₂	B ₂

LEVER ANGLE											
Pump Model	6/7	8/7	9/7	11/7	12/7	13/7	15/9	17/9	18/9	19/9	21/9
Lever Angle (X - Y)	10°	12°	13°	15°	17°	18°	15°	17°	18°	19°	19°



(continued)

DMZ

CONTROL LEVER WITH RETURN TO ZERO POSITION

(compression spring)

HYDRAULIC DIAGRAM

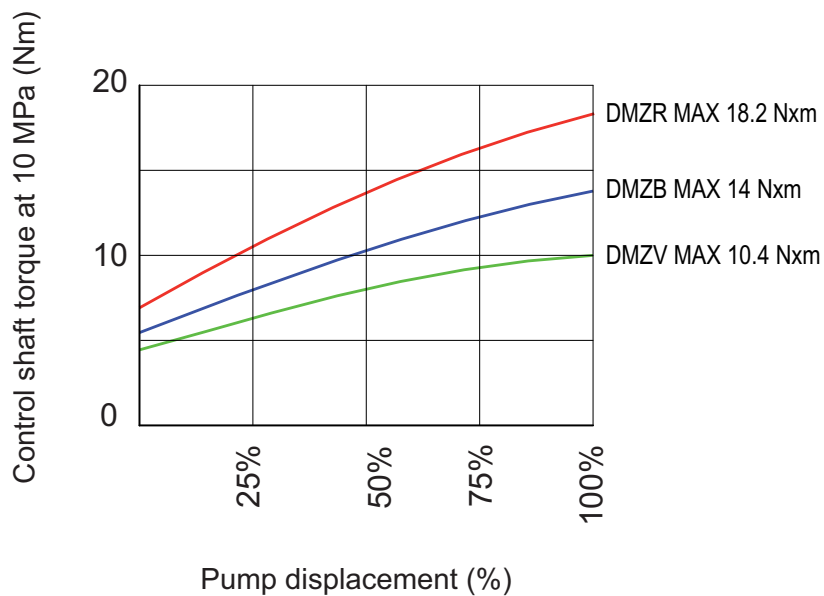
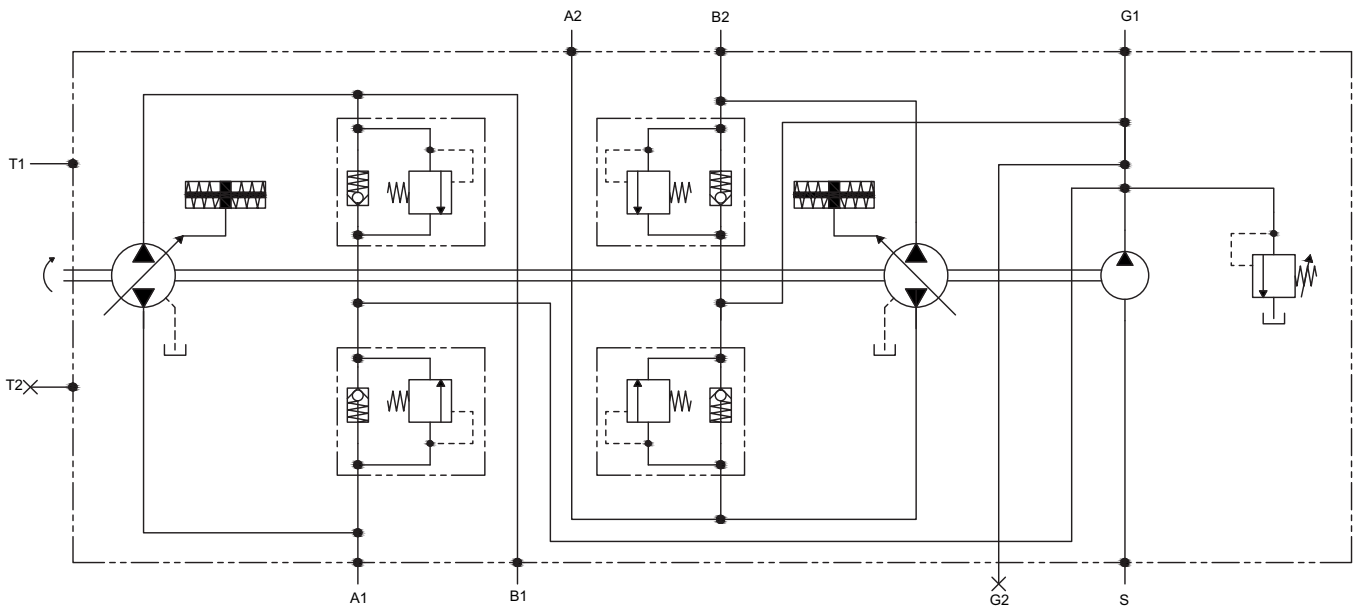

SHI

INTEGRATED REMOTE HYDRAULIC SERVO CONTROL

The pump displacement variation is obtained by adjusting the pressure on P1, P2, P3 and P4 servo control ports by means of a hydraulic proportional joystick (with integrated pressure reducing valves).

The servo control supply can be obtained by taking pressure from the boost pump (G1- G2 ports), see pag. 17.

The servo control return time can be adjusted by inserting a restrictor on the joystick supply line (0,5 ÷ 1,2 mm).

The servo control operation curve, in both directions, goes from 0,4 to 1,8 MPa (tolerance ± 5 %).

The adjusting curve of the hydraulic joystick has to be a little wider (0,3 ÷ 1,9 MPa).

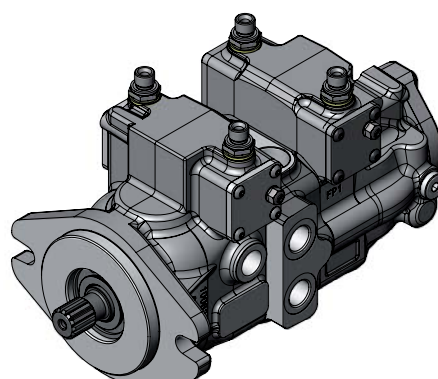
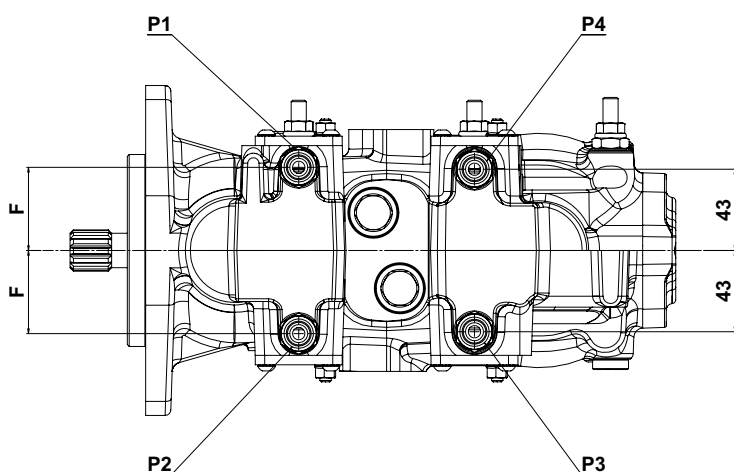
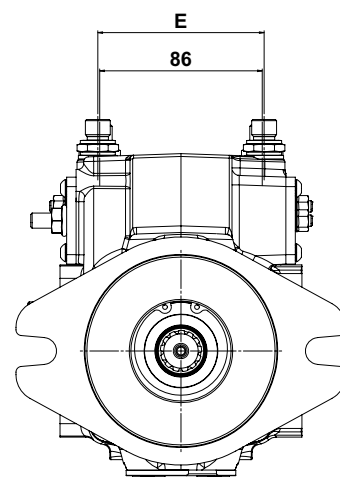
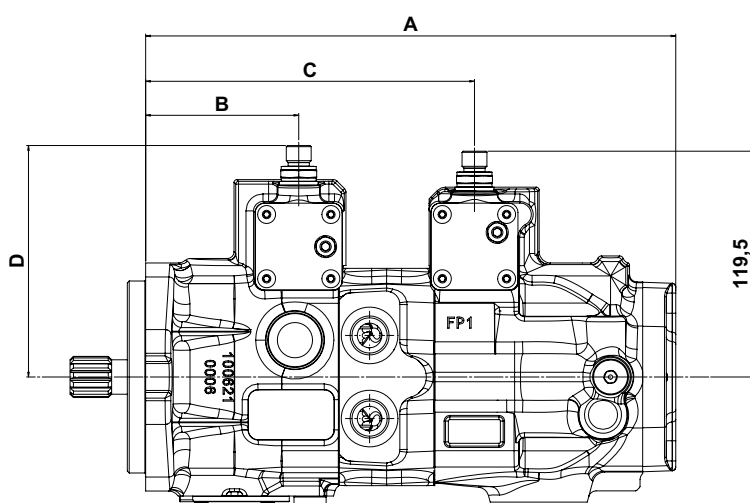

GENERAL DIMENSIONS (mm)		
REFERENCE	F1 - SAE A	F2.1 - SAE B
A	279,5	280,5
B	80	81
C	173	174
D	120	122,5
E	103	88
F	51,5	44



(continued)

SHI

INTEGRATED REMOTE HYDRAULIC SERVO CONTROL

HYDRAULIC DIAGRAM

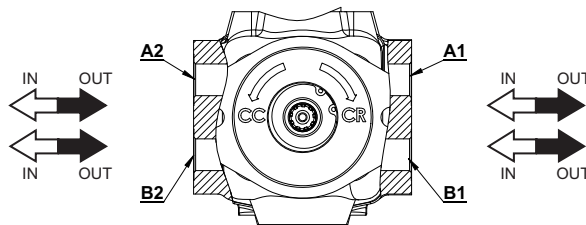
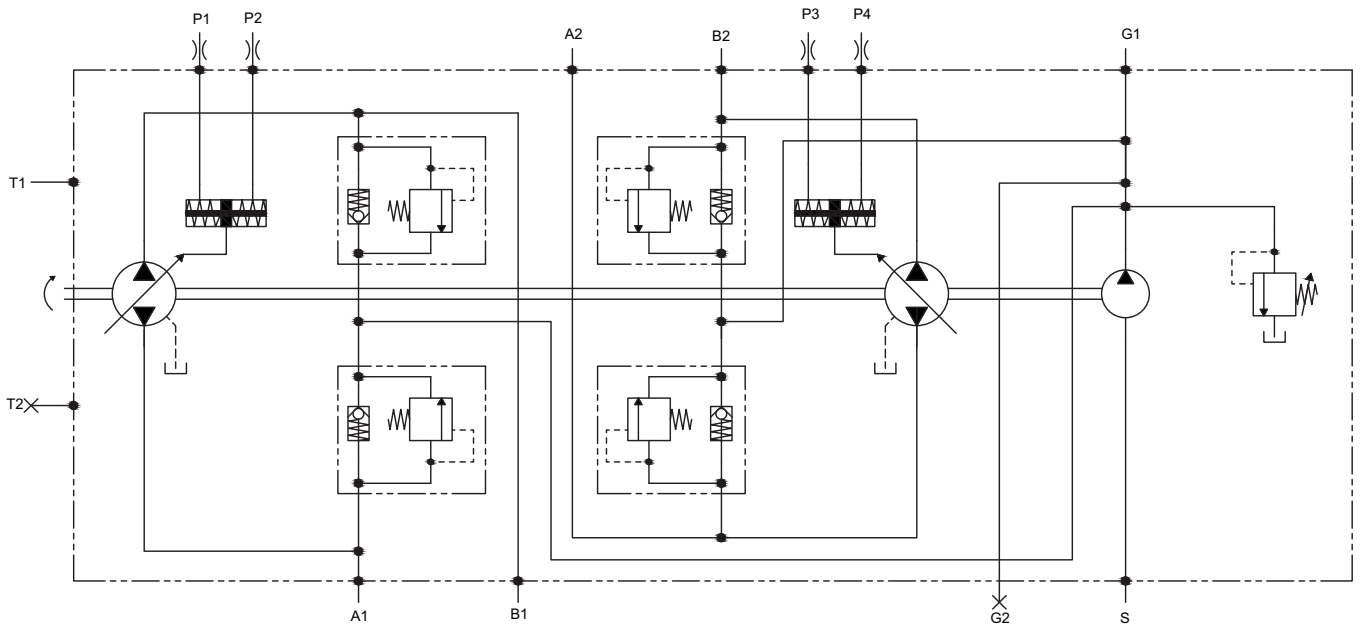

FLOW DIRECTION	PRIMARY PUMP			SECONDARY PUMP		
	Port	OUT	IN	Port	OUT	IN
Clockwise (CR)	P ₁ P ₂	B ₁ A ₁	A ₁ B ₁	P ₁ P ₂	A ₂ B ₂	B ₂ A ₂
Counter clockwise (CC)	P ₁ P ₂	A ₁ B ₁	B ₁ A ₁	P ₁ P ₂	B ₂ A ₂	A ₂ B ₂

SHIC

COMPACT HYDRAULIC CONTROL

(with side pilot ports)

The pump displacement variation is obtained by adjusting the pressure on P1, P2, P3 and P4 servo control ports by means of a hydraulic proportional joystick (with integrated pressure reducing valves). The servo control supply can be obtained by taking pressure from the boost pump (G1- G2 ports), see pag. 17.

The servo control return time can be adjusted by inserting a restrictor on the joystick supply line (0,5 ÷ 1,2 mm). The servo control operation curve, in both directions, goes from 0,4 to 1,8 MPa (tolerance (± 5 %).

The adjusting curve of the hydraulic joystick has to be a little wider (0,3 ÷ 1,9 MPa).

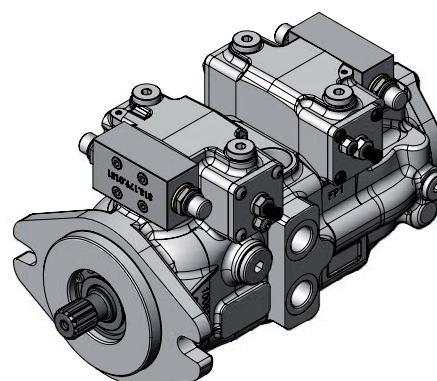
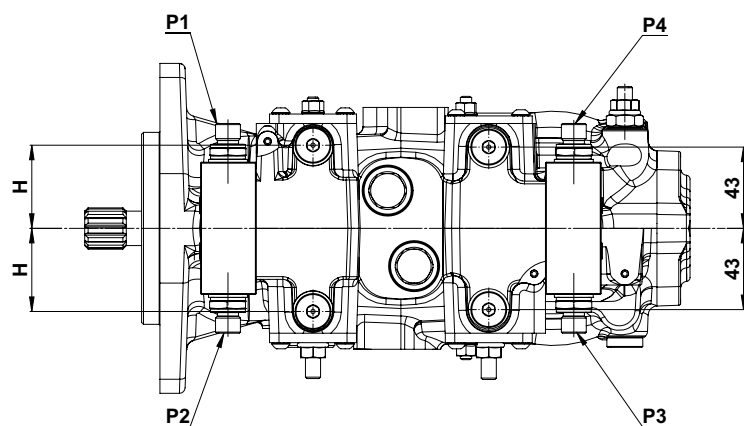
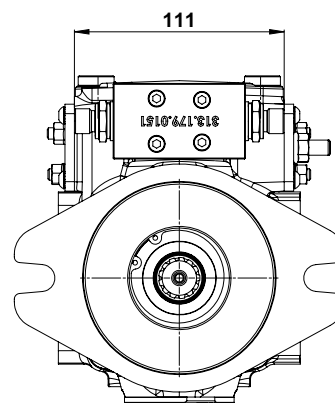
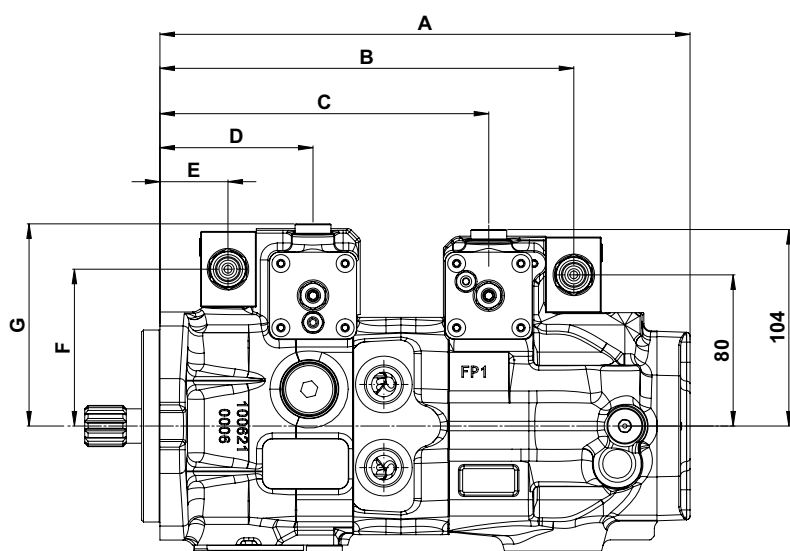

GENERAL DIMENSIONS (mm)		
REFERENCE	F1 - SAE A	F2.1 - SAE B
A	279	280,5
B	218	219
C	172	174
D	79	81
E	35	36
F	79,5	83
G	104,5	107
H	51,5	44



(continued)

SHIC

COMPACT HYDRAULIC CONTROL

(with side pilot ports)

HYDRAULIC DIAGRAM

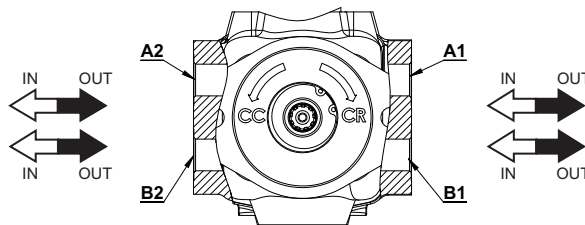
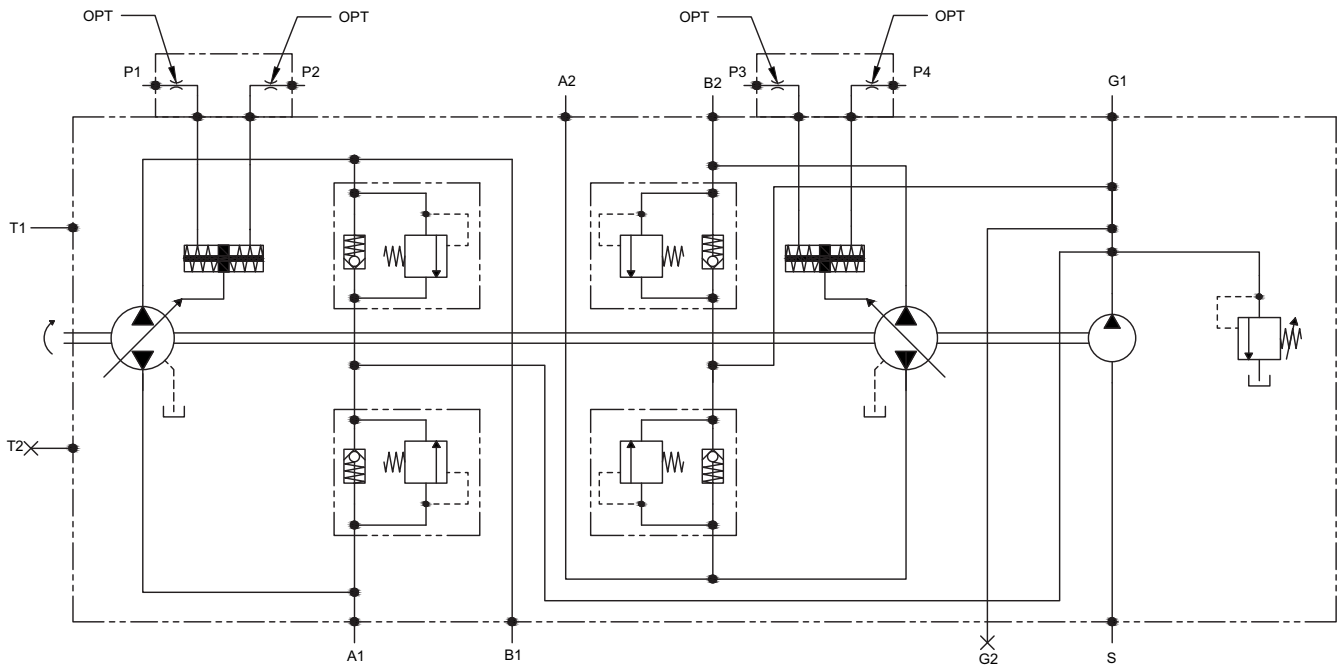

FLOW DIRECTION	PRIMARY PUMP			SECONDARY PUMP		
	Port	OUT	IN	Port	OUT	IN
Clockwise (CR)	P ₁	B ₁	A ₁	P ₁	A ₂	B ₂
	P ₂	A ₁	B ₁	P ₂	B ₂	A ₂
Counter clockwise (CC)	P ₁	A ₁	B ₁	P ₁	B ₂	A ₂
	P ₂	B ₁	A ₁	P ₂	A ₂	B ₂

SEI 1.3 (12V DC)
SEI 2.3 (24V DC)

PROPORTIONAL ELECTRIC SERVO CONTROL
(AMP junior timer connector)

The pump pump variation is obtained by an electric signal that goes from:

- 0 to 750 mA (24V DC voltage)
- 0 to 1500 mA (12V DC voltage)

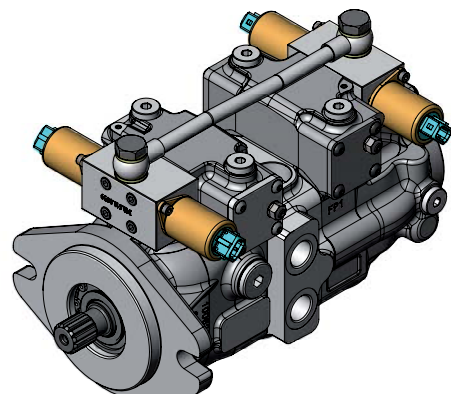
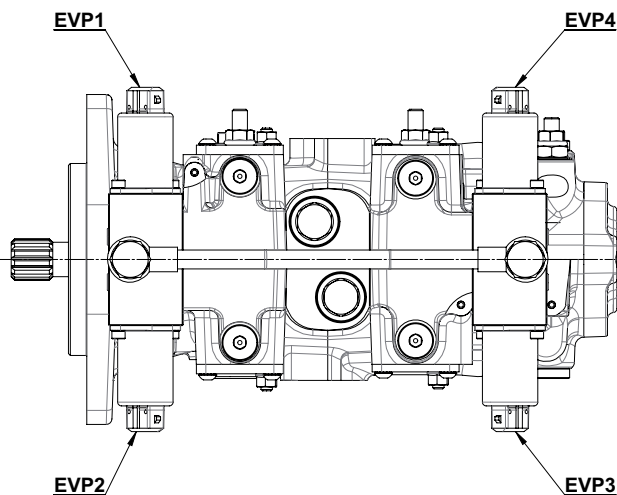
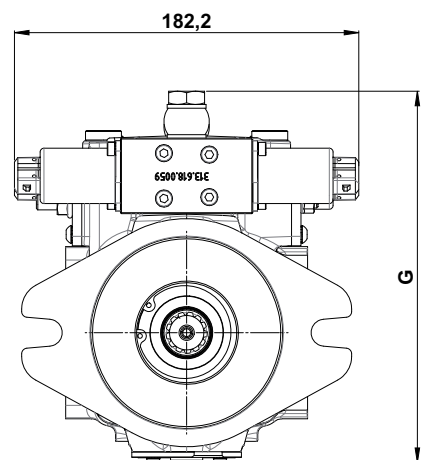
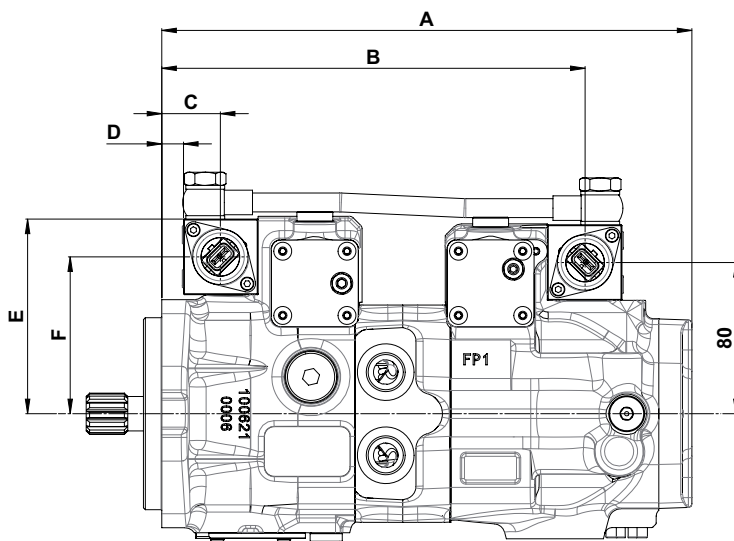

GENERAL DIMENSIONS (mm)		
REFERENCE	F1 - SAE A	F2.1 - SAE B
A	179,5	280,5
B	223	224
C	30	31
D	10,5	11,5
E	99,5	103
F	79,5	83
G	192,5	196,5



(continued)

SEI 1.3 (12V DC)



SEI 2.3 (24V DC)

PROPORTIONAL ELECTRIC SERVO CONTROL

(AMP junior timer connector)

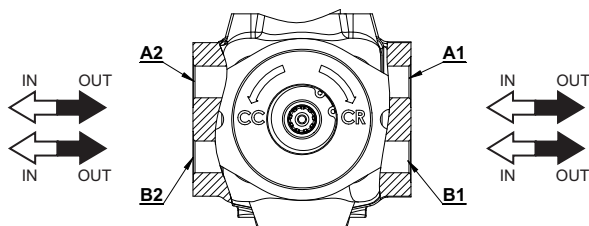
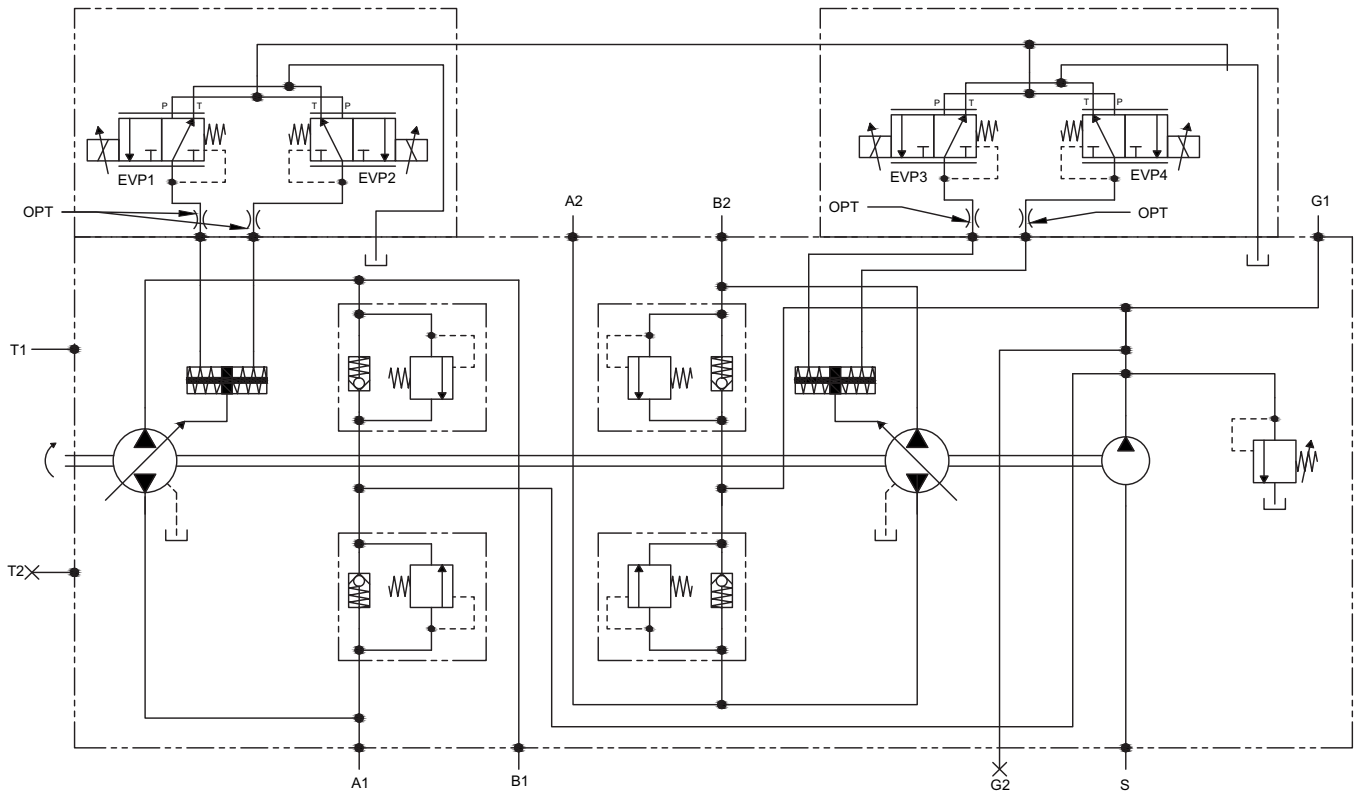
HYDRAULIC DIAGRAM



FLOW DIRECTION	PRIMARY PUMP			SECONDARY PUMP		
	 EVP	OUT	IN	 EVP	OUT	IN
Clockwise (CR)	EVP1 EVP2	B ₁ A ₁	A ₁ B ₁	EVP3 EVP4	A ₂ B ₂	B ₂ A ₂
Counter clockwise (CC)	EVP1 EVP2	A ₁ B ₁	B ₁ A ₁	EVP3 EVP4	B ₂ A ₂	A ₂ B ₂

(continued)

SEI 1.3 (12V DC)

SEI 2.3 (24V DC)

PROPORTIONAL ELECTRIC SERVO CONTROL

(AMP junior timer connector)

CURRENT-DISPLACEMENT GRAPHIC

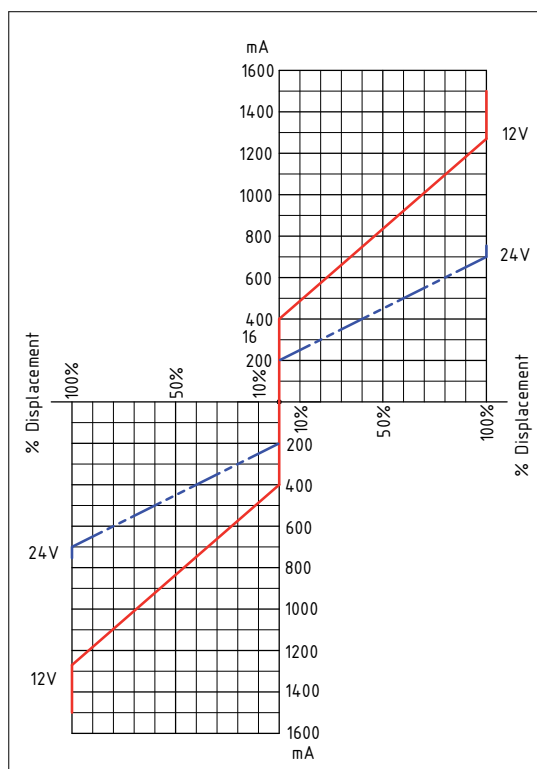

ELECTRICAL FEATURES		
Voltage	12 V DC	24 V DC
Electric current	1500 mA	750 mA
Load resistance	4,72 Ω ± 5%	20,8 Ω ± 5%
Type of control	Current control	
	PWM 100 Hz (suggested)	
Type of connection	AMP Junior Timer	
Protection class	Until IP6K6 / IPX9K	

HYDRAULIC FEATURES	
Max. pressure (P, T)	pP= 5 MPa, pT= 3 MPa
Hysteresis (w/PWM)	<0,07 MPa (pA=2,0)
	<0,1 MPa (pA=2,5)
	<0,15 MPa (pA=3,5)
Filtration ratio	125 μm
Oil contamination level	Min. filtration ratio: 20/18/15
	According ISO 4406
	Hydraulic oil DIN 51524
Min./max. oil temperature	From -20 to +90°C

CONTROL DEVICE POSITION

(Primary and Secondary Pump)

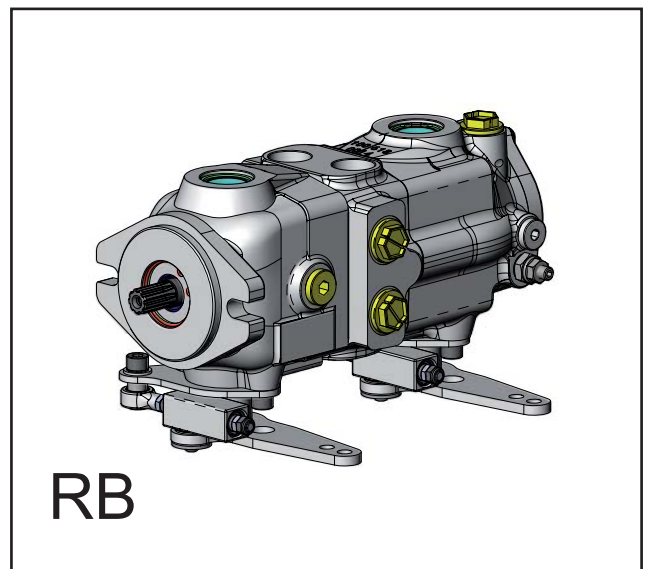
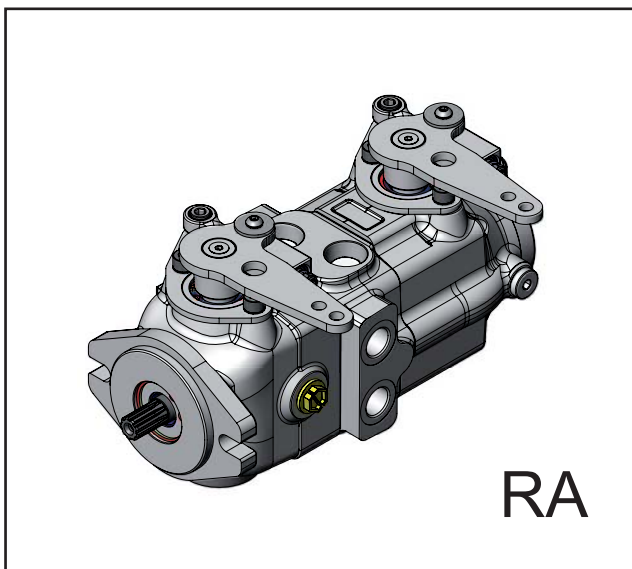
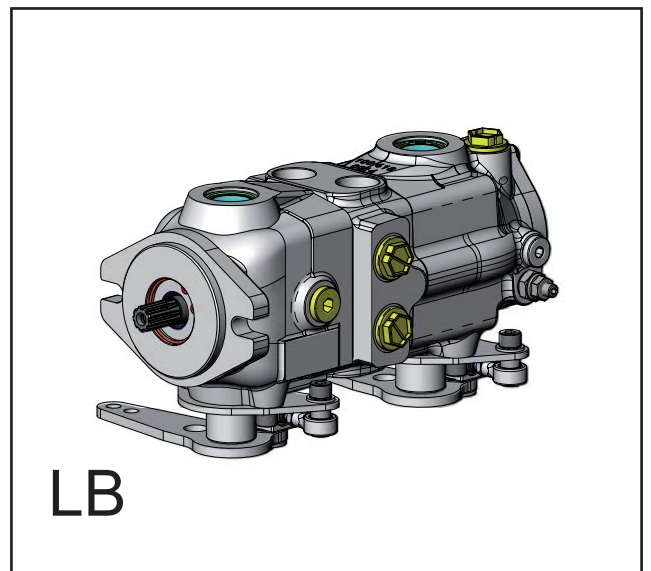
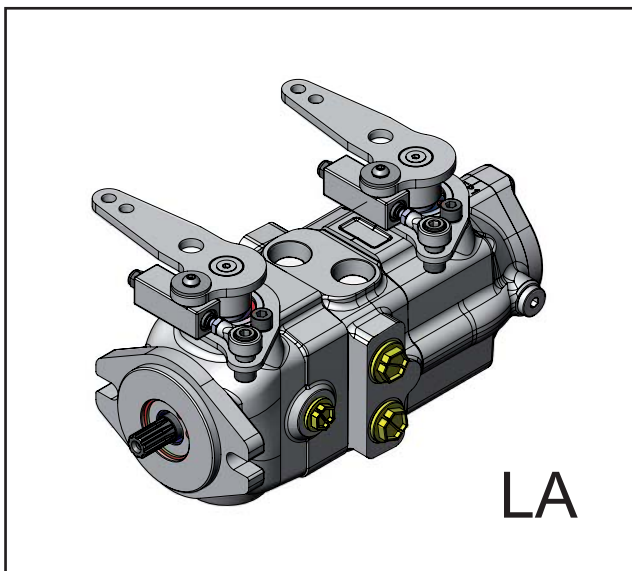
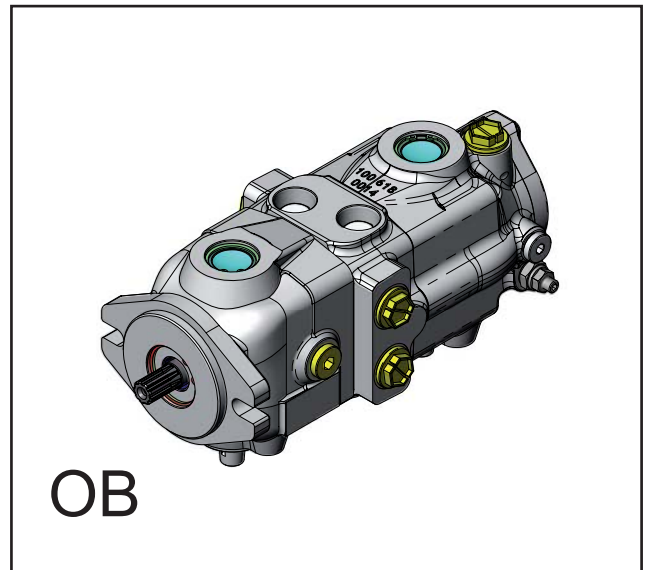
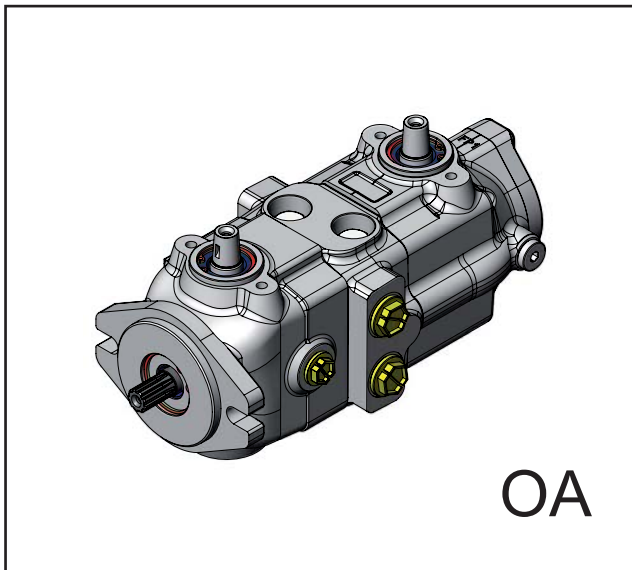

REAR PUMP MOUNTING FLANGES

C
CLOSED COVER WITHOUT REAR FITTING

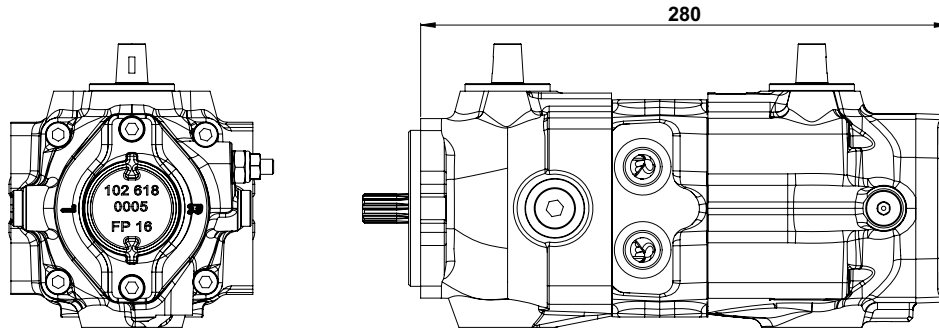

B1
GERMAN STANDARD

Four possible mounting positions (every 90°)
Max. torque = 70 Nm

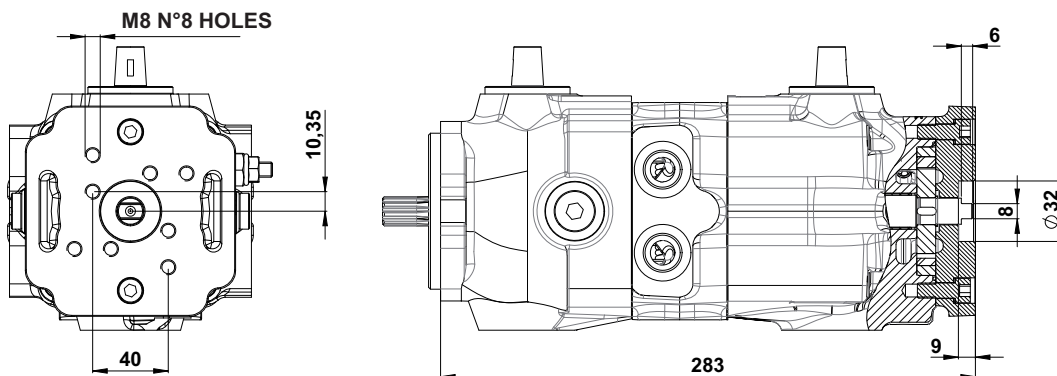

B2
GERMAN STANDARD

Four possible mounting positions (every 90°)
Max. torque = 70 Nm

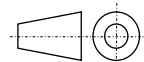
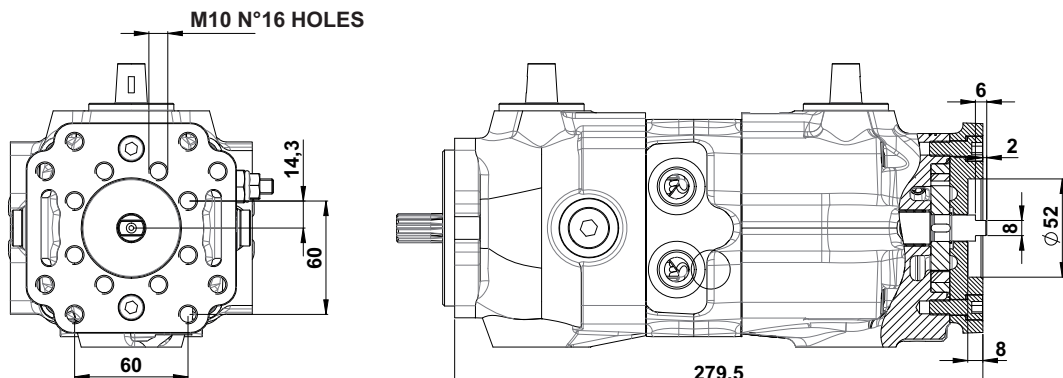

OPTIONAL FB

ADAPTOR FLANGE FROM SAE A - SAE B

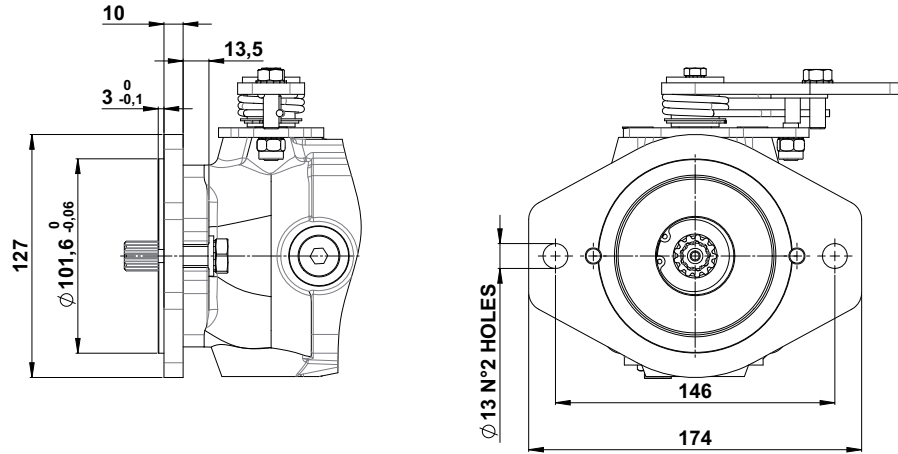

OPTIONAL ST

ADAPTOR COUPLING Z=9 / Z=13 - 16/32" DP

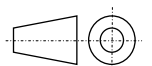
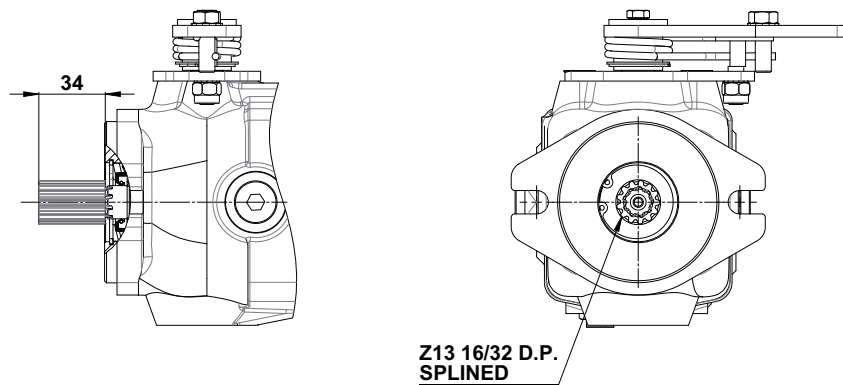

OPTIONAL VS-SB

PURGE VALVE WITH SCREW BY-PASS

The TPV 1200 BTB pumps are available with purge valve (loop flushing) with screw by-pass. The valve consists of a spring centered shuttle spool connecting automatically the low pressure line (boost) with the reservoir removing heat from the system. The quantity of the flushing oil is a function of the low system pressure (boost) and the size of the orifice on the valve (different orifices are available referred to the system pressure). The spool shifts at a differential pressure of about 0,8 MPa (116 PSI).

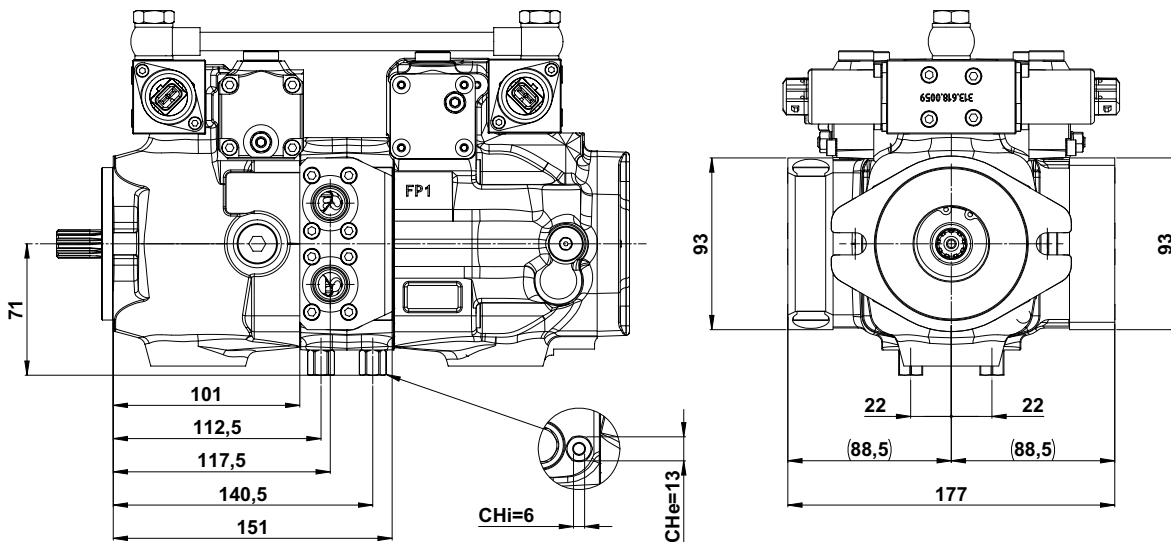
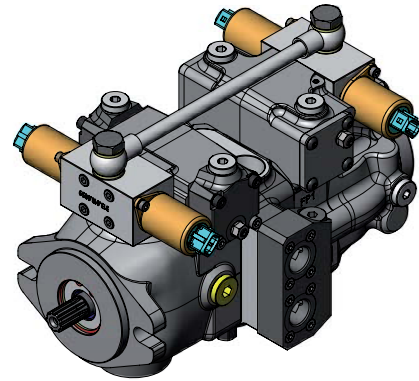

HYDRAULIC DIAGRAM

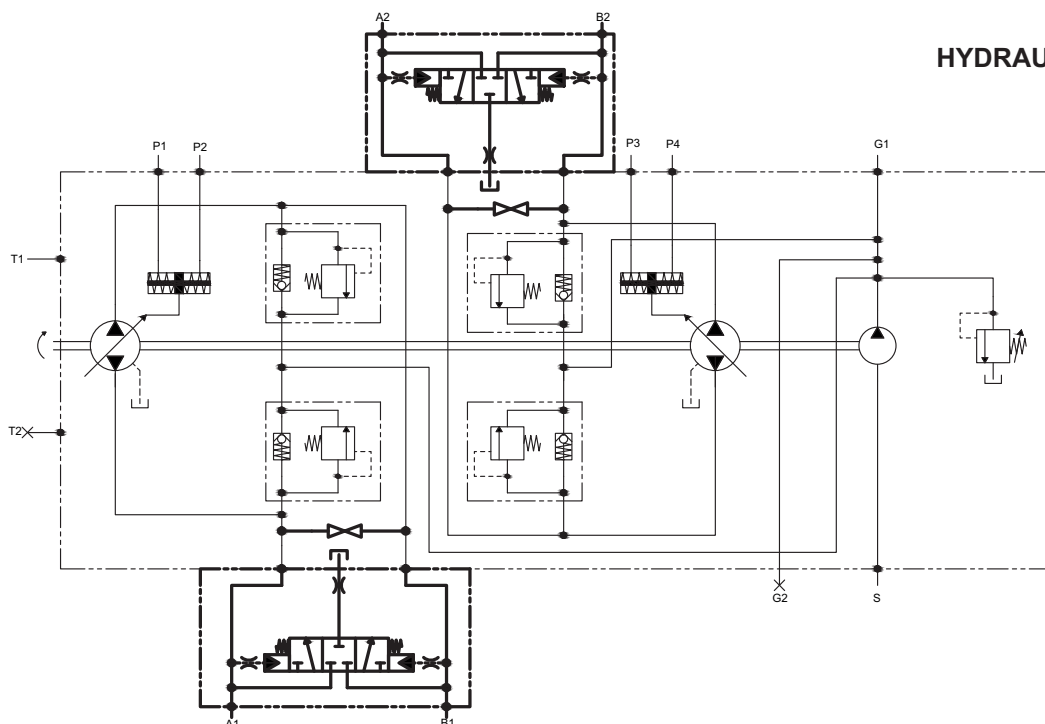

OPTIONAL VS-SB1

PURGE VALVE WITH SCREW BY-PASS (180° rotated position)

The TPV 1200 BTB pumps are available with purge valve (loop flushing) with screw by-pass in 180° rotated position.

The valve consists of a spring centered shuttle spool connecting automatically the low pressure line (boost) with the reservoir removing heat from the system. The quantity of the flushing oil is a function of the low system pressure (boost) and the size of the orifice on the valve (different orifices are available referred to the system pressure). The spool shifts at a differential pressure of about 0,8 MPa (116 PSI).

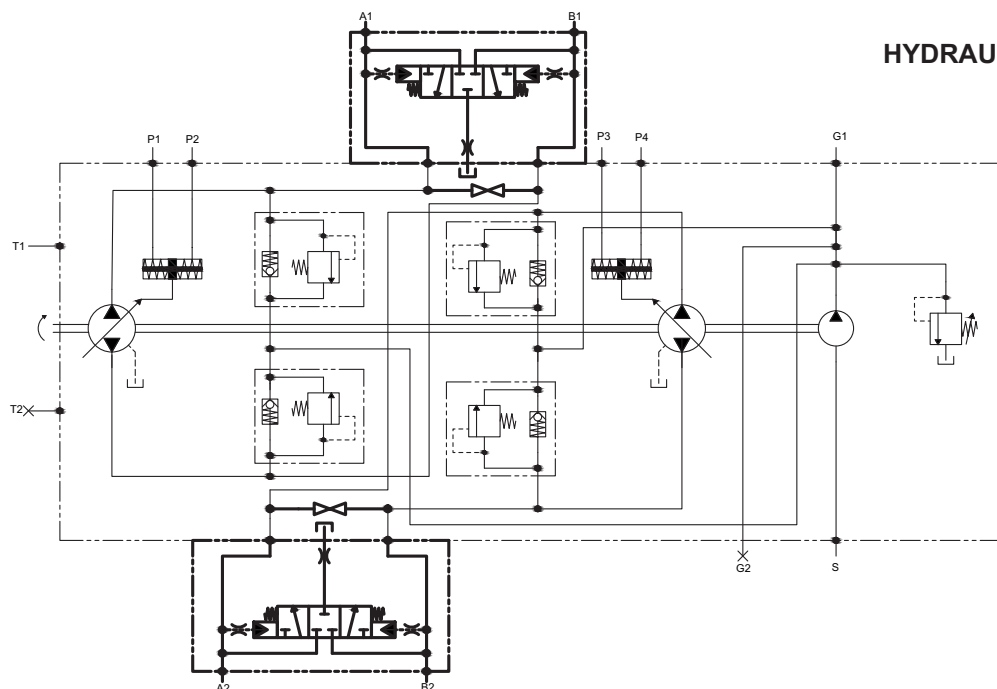
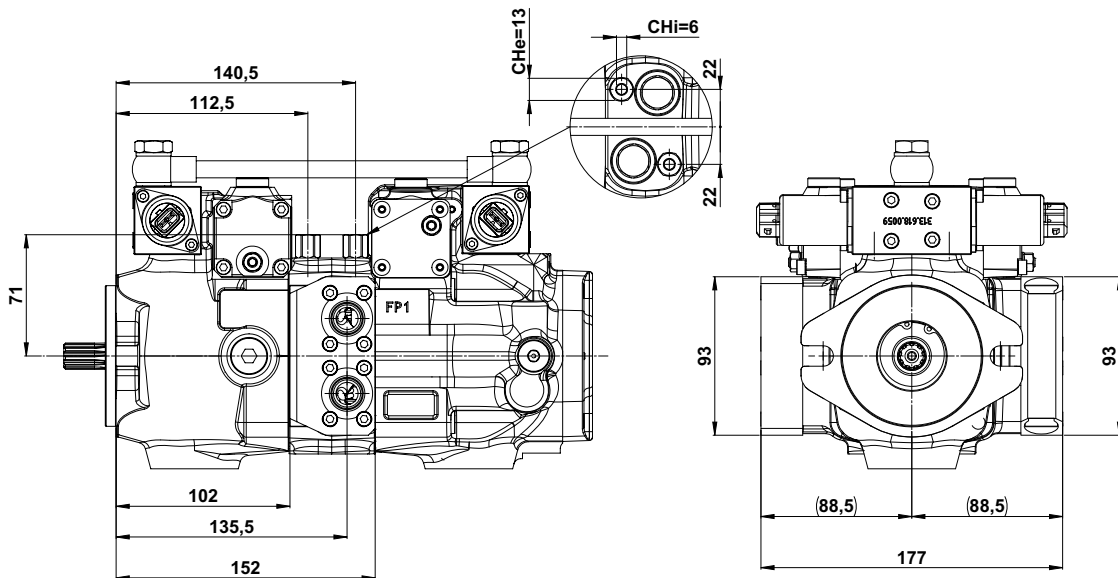
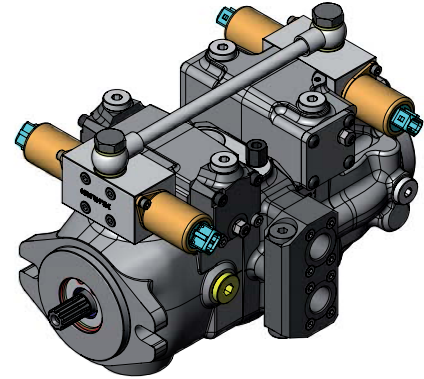

HYDRAULIC DIAGRAM

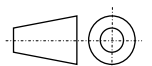

OPTIONAL SB

SCREW BY-PASS

To by pass the oil flow from one direction to the other, with the pump not running or in emergency condition a by pass screw can be actuated to connect the 2 lines of the hydraulic system. The orifice is completely open after 4 counter-clockwise rotations of the screw.

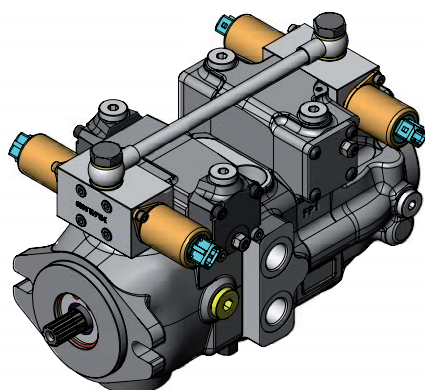
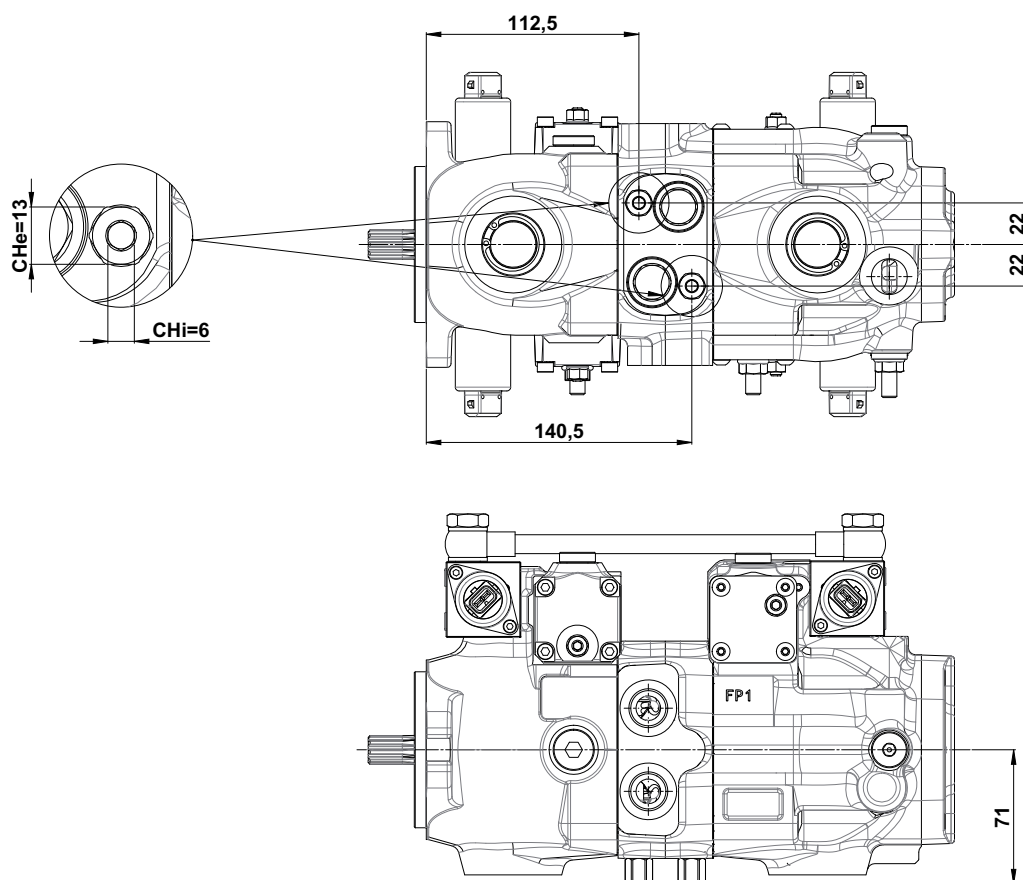

(continued)

OPTIONAL SB

SCREW BY-PASS

HYDRAULIC DIAGRAM

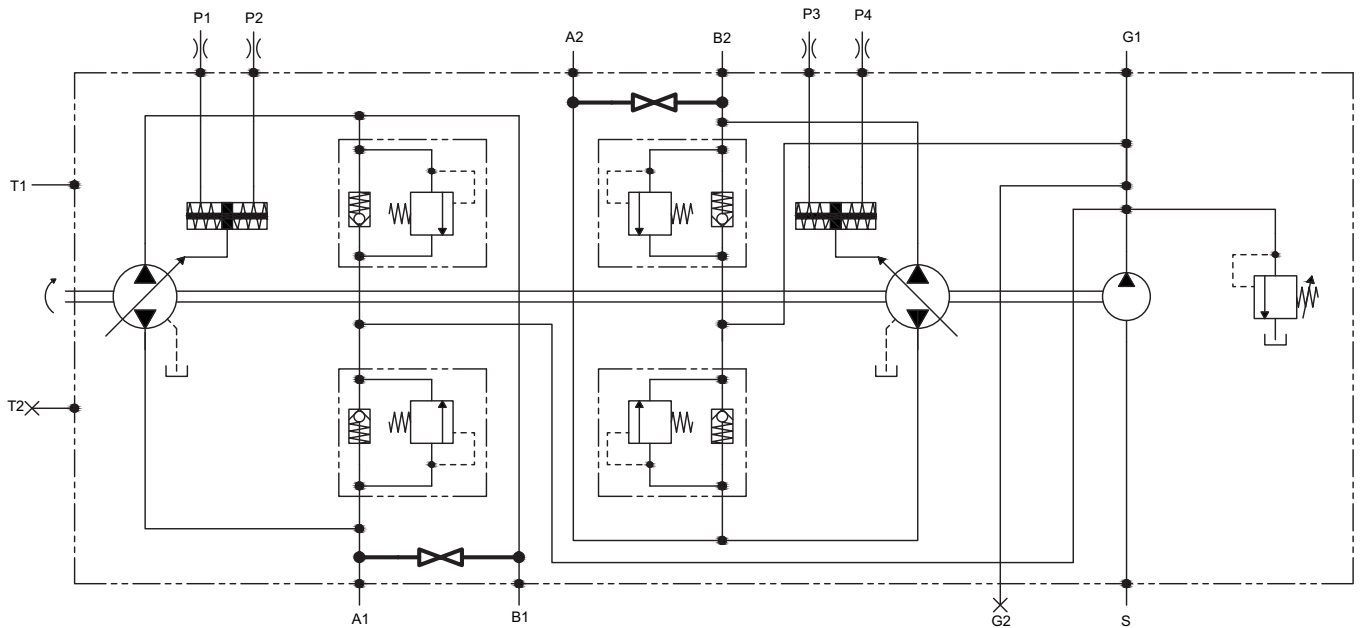

OPTIONAL SB1

SCREW BY-PASS (180° rotated position)

To by pass the oil flow from one direction to the other, with the pump not running or in emergency condition a by pass screw can be actuated to connect the 2 lines of the hydraulic system. The orifice is completely open after 4 counter-clockwise rotations of the screw.

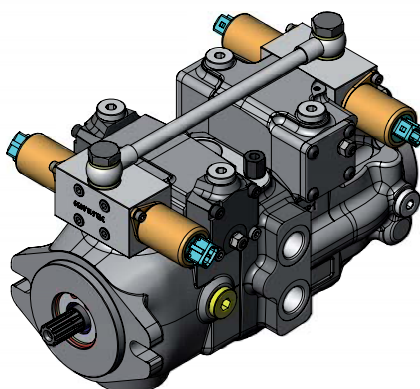
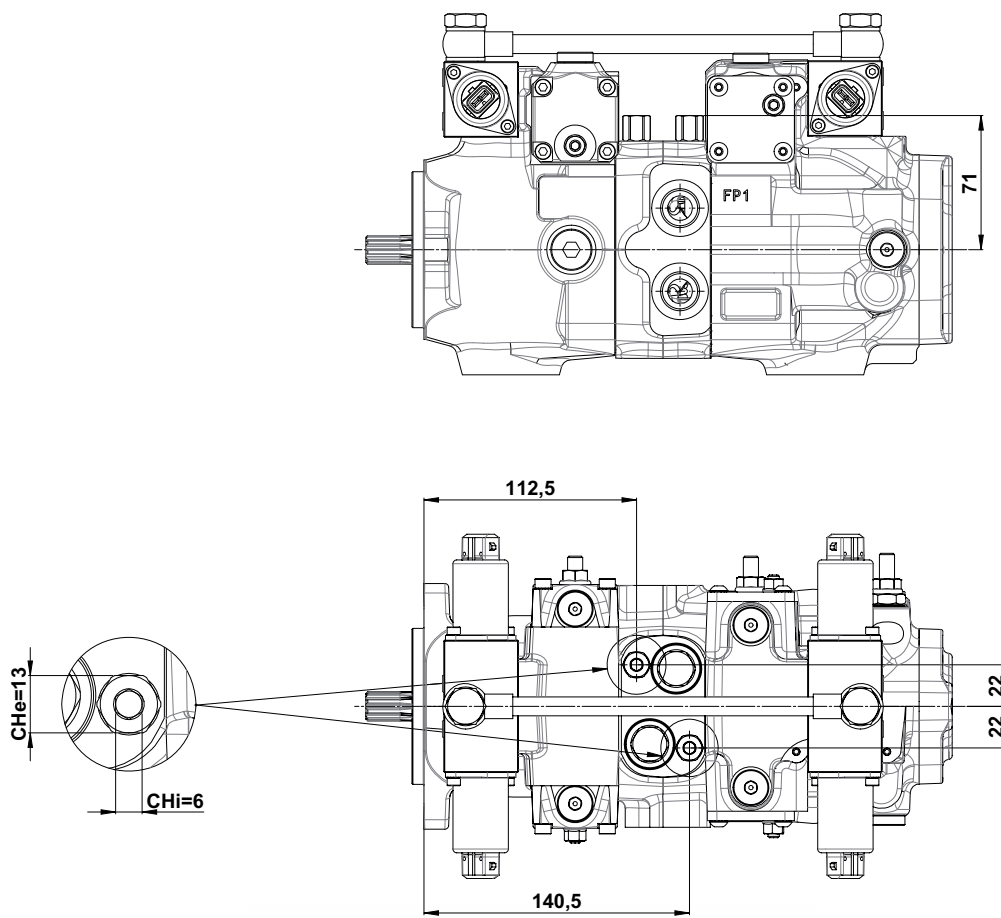

(continued)

OPTIONAL SB1

SCREW BY-PASS (180° rotated position)

HYDRAULIC DIAGRAM

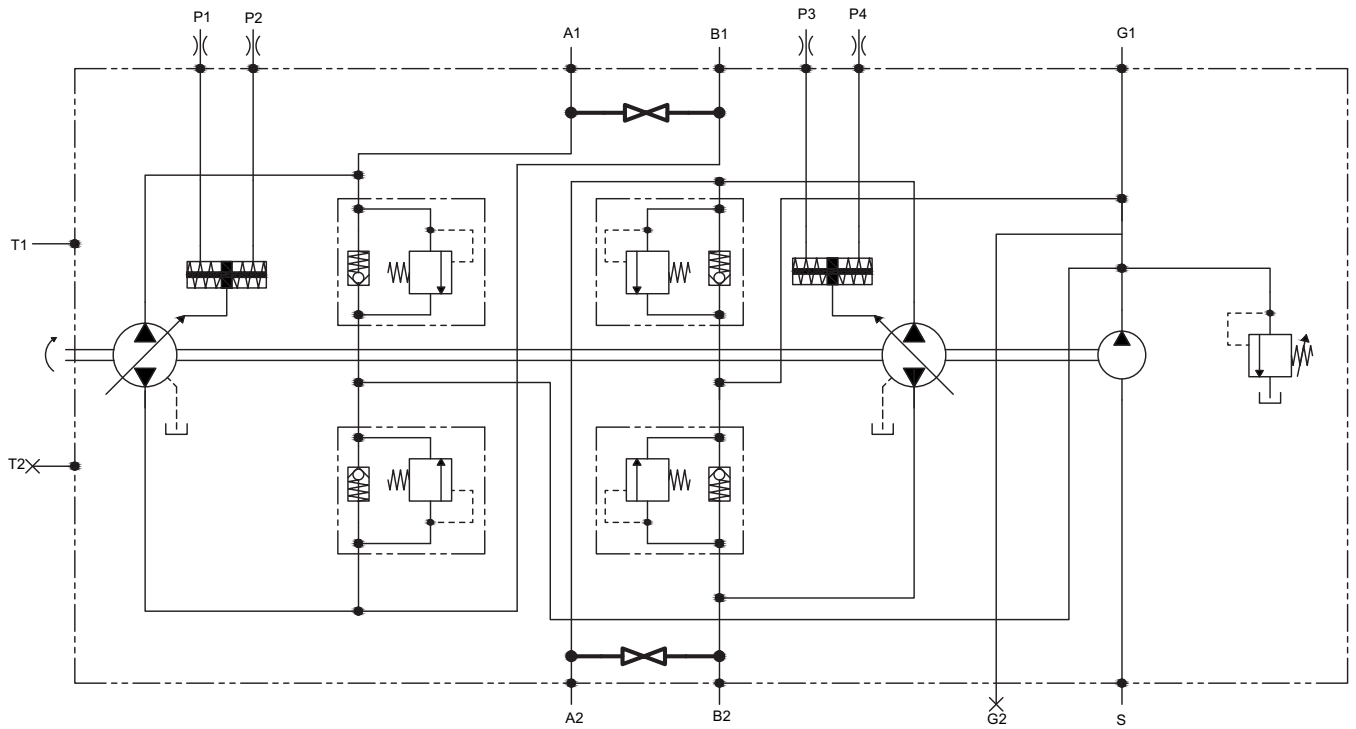

OPTIONAL MOB

MAN ON BOARD

A normally open solenoid valve cuts the oil flow when not activated.

The valve allows oil flow to feed the hydraulic system only if activated (the operator is seated).

The solenoid valve is available for 12V or 24V DC voltage.

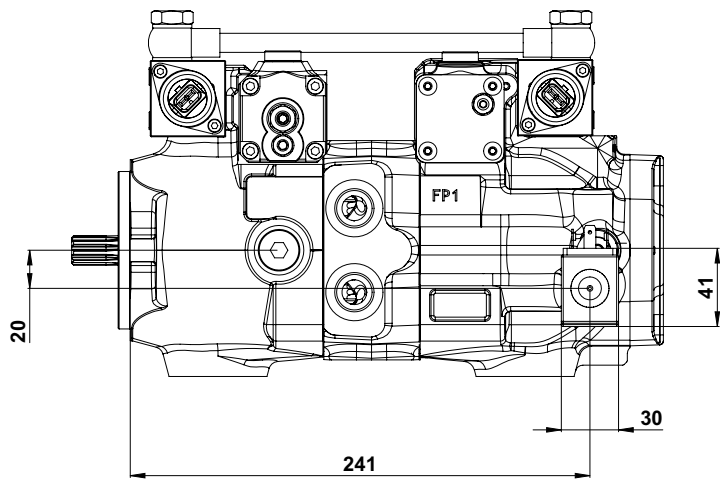
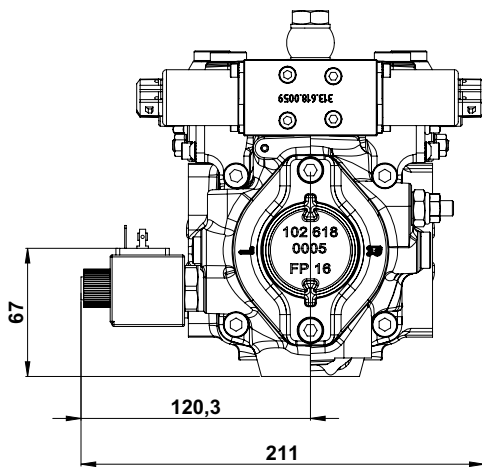
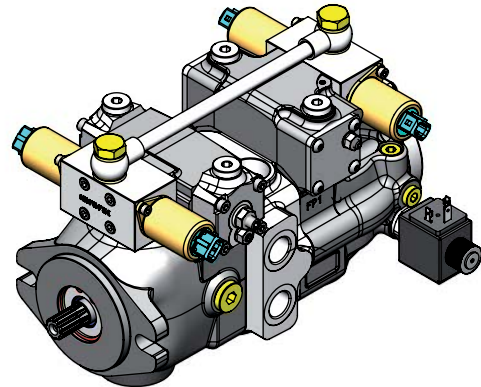

HYDRAULIC DIAGRAM

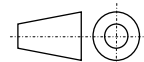
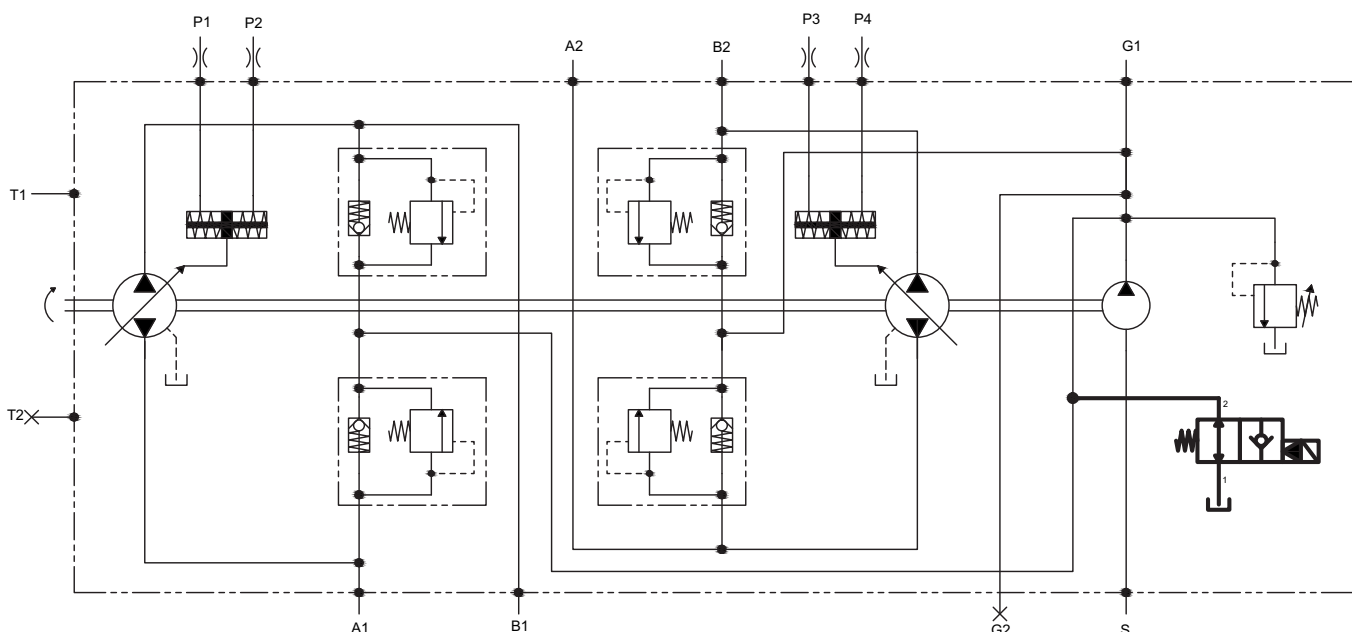

(continued)

OPTIONAL MOB

MAN ON BOARD

TECHNICAL FEATURES

VALVE MOB - Hydraulic characteristics	
Max. operating pressure	30 MPa
Max. flow	40 lt/min.
Internal leakage	max. 5 drops/min. at 30 MPa
Response time	energized 20 ms
De-energized	30 ms
Temperature range	from -20°C to 90°C



VALVE MOB - Electrical characteristics	
Power	18 W
Various voltage options available	(AC/DC)
Wire insulation	Class H
Duty factor	ED 100%
Supply power tolerance	+ 10%, - 15% (DC)
Ambient temperature	from -30°C to 60°C
Several connection options available	

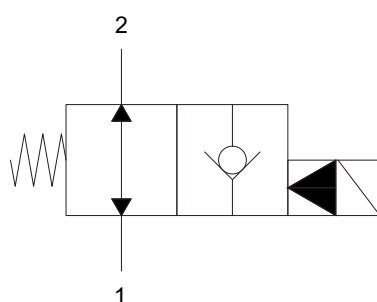

TROUBLE SHOOTING

TROUBLES	CAUSE	REMEDY
High noise level	Too high rotation speed of the pump.	Reduce pump rotation speed.
	Wrong rotation direction.	Check the rotation direction of the pump.
	Obstruction in suction line - air in the suction line - wrong oil viscosity - diameter of suction line too small.	Check oil type and viscosity. Check internal diameter of suction line. Remove restrictions. Check oil level of reservoir. Eliminate air intake.
	Not correct connection of the pump. Not correct diameter of pipes / hoses.	Check the pump connections and the pipe / hose diameters according to notes.
	Vibrations of relief valves .	Check the inlet suction line - Check and replace relief valves.
	Internal parts worn out.	Check and replace.
	Wrong pump connection to the prime mover.	Check connections and rotation of direction.
Low flow rate	Too low rotation speed of the pump.	Increase the pump rotation speed.
	Obstructions in the suction line - wrong viscosity.	Check oil type and viscosity. Check internal diameter of suction line. Remove restrictions. Check oil level of reservoir. Eliminate air intake.
	Low remote control pressure.	Check and adjust.
	High internal leakage.	Check the case drain flow.
Instable or low pressure	Low rotation speed of the pump.	Increase speed of the pump.
	Obstruction of suction line - air in the suction line - wrong oil viscosity - diameter of suction line too small.	Check oil type and viscosity. Check internal diameter of suction line. Remove restrictions. Check oil level of reservoir. Eliminate air intake.
	Vibration of relief valves.	Check the inlet suction line. Check and replace relief valves.
Over heating	Internal parts worn out.	Check and replace.
	High oil temperature at suction inlet.	Check the cooling system.
	Wrong setting of pressure relief valves.	Check - adjust the setting of relief valves.

ACCESSORIES

Hydraulic Gear Pump German Standard **B1**
Hydraulic Gear Pump German Standard **B2**

For more detailed information ask
for catalogue HT 15 F 20.....

Hydraulic Remote Servo Controls



For more detailed information ask
for catalogue HT 73 B 10.....

Electric Remote Servo Controls



For more detailed information ask
for catalogue HT 73 B 20.....

Flanges and Couplings for Gasoline and Diesel engines

GASOLINE OR DIESEL ENGINES

FLANGES AND COUPLINGS

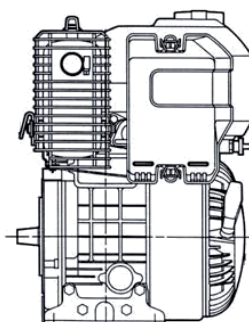
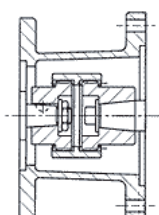

For more detailed information ask
our technical department

TRIPLE PUMP - CONFIGURATION EXEMPLE

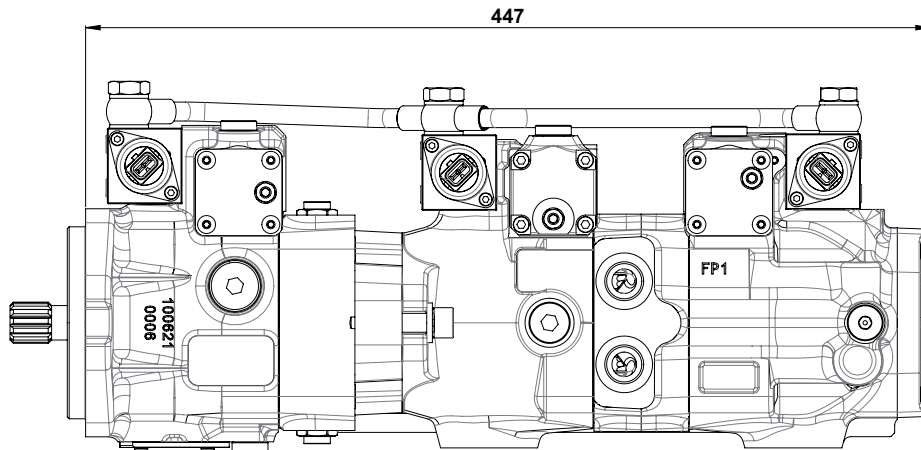

HYDRAULIC DIAGRAM

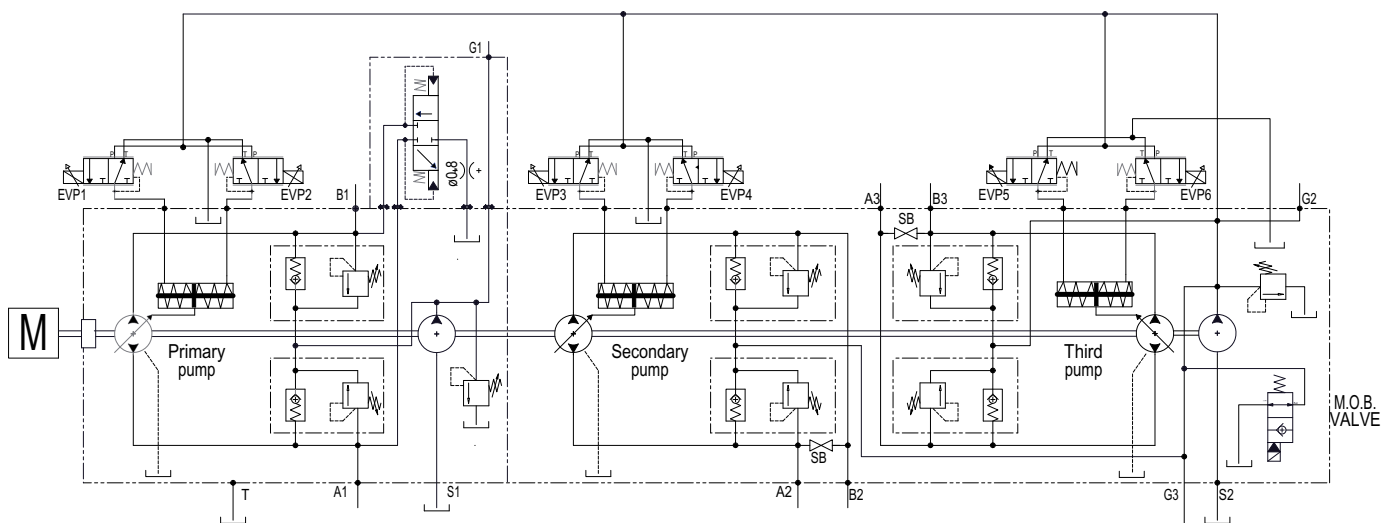

As HANSA-TMP has a very extensive range of products and some products have a variety of applications, the information supplied may often only apply to specific situations.

If the catalogue does not supply all the information required, please contact HANSA-TMP.

In order to provide a comprehensive reply to queries we may require specific data regarding the proposed application.

Whilst every reasonable endeavour has been made to ensure accuracy, this publication cannot be considered to represent part of any contract, whether expressed or implied.

The data in this catalogue refer to the standard product.

The policy of HANSA-TMP consists of a continuous improvement of its products. It reserves the right to change the specifications of the different products whenever necessary and without giving prior information.



HYDRAULIC COMPONENTS
HYDROSTATIC TRANSMISSIONS
GEARBOXES - ACCESSORIES

Via M. L. King, 6 - **41122 MODENA (ITALY)**
Tel: +39 059 415 711
Fax: +39 059 415 729 / 059 415 730
INTERNET: <http://www.hansatmp.it>
E-MAIL: hansatmp@hansatmp.it