



HYDRAULIC COMPONENTS
HYDROSTATIC TRANSMISSIONS
GEARBOXES - ACCESSORIES

Certified Company ISO 9001 - 14001



Via M. L. King, 6 - 41122 MODENA (ITALY)

Tel: +39 059 415 711

Fax: +39 059 415 729 / 059 415 730

INTERNET: <http://www.hansatmp.it>

E-MAIL: hansatmp@hansatmp.it

HT 16 / M / 902 / 0516 / E

THE PRODUCTION LINE OF HANSA-TMP

Fixed Displacement Axial Piston Motor for Open and Closed Loop System

TMF 900



CONTENTS

General Information.....	4
Technical Specifications.....	4
Order Code.....	5
Installation Drawings.....	6 - 7
Technical Manual.....	8 - 10

MAIN FEATURES**General Information**

This is a fixed displacement motor with axial pistons, swash plate design and can be used in closed and open loop systems. The motor was developed for use on hydraulic transmissions, where high speeds and high torques are demanded.

The construction features help to minimize the losses due to leakage and considerably reduces the frictions. The small sizes allow easy installation.

The motor is equipped with flushing valve integrated on the motor casing which allows the temperature control, especially in heavy duty applications.

TECHNICAL SPECIFICATIONS**Operating Parameters**

Model		TMF 900	72	90	110
Displacement	V	cm ³	72	90	110
Maximum speed	n _{max}	rpm	4.100	4.000	3.800
Maximum flow	q _{max}	l/min.	295	340	400
Nominal pressure	p _{nom}	bar	400	400	400
Maximum pressure	p _{max}	bar	450	450	450
Maximum power	P _{max}	Kw	156	180	210
Theoretical max torque	C _{max}	Nm	480	570	700

Hydraulic Fluid

Recommended Hydraulic Fluid	Mineral Oil High Viscosity Index		
Operating viscosity *	v	cSt	16 ÷ 36
Maximum viscosity short term at cold start	v _{max}	cSt	≤1600
Minimum viscosity at maximum temperature	v _{min}	cS	≥7
Maximum working temperature of the fluid	T _{max}	°C	90
Permissible temperature range of seals	ΔT	°C	-25 ÷ 120

*Referred to the circuit temperature-closed circuit

Filtration

It is recommended for an efficient and lasting working life, a solid particle contamination level of 18/16/13 according to ISO 4406. To ensure said level of contamination is not exceeded, filter should be chosen accordingly, with filtration grade of $\beta_{10} \geq 2$.

In any case the contamination level must not be below 20/18/15 according to ISO 4406.

Safety Regulation

This publication provides just an overview of the product and it is addressed to skilled personnel properly equipped to perform maintenance. During maintenance, assembly and disassembly activities use caution and proper safety equipment, in observance of the rules provided by safety laws.

ATTENTION

The motors are made with heavy parts: secure the parts and use proper lifting equipment.

ORDER CODE

EXAMPLE						
1	2	3	4	5	6	7
TMF 900	90	V	C4	2IN	RO	F18

1	PRODUCT GROUP AND FAMILY
TMF 900	Fixed displacement axial piston motor

2	DISPLACEMENT
72	72,1 cm ³ (@18°)
90	89,2 cm ³ (@18°)
110	110,0 cm ³ (@18°)

3	SHAFT SEAL	72	90	110
V	Viton	A	A	A

4	MOUNTING FLANGE	72	90	110
C4	SAE J 744 - SAE C four bolts	A	A	A

5	SHAFT END	72	90	110
2IN	ANSI B92.1A - 1976 - 1"3/8 - 21T - 16/32 DP	A	A	A

6	SERVICE LINE PORTS	72	90	110
RO	Radial opposite side	A	A	A

7	FLUSHING VALVE SETTINGS	72	90	110
0	Without pressure valve	R	R	R
F20	20 bar	A	A	A
F18	18 bar	R	R	R
F16	16 bar	R	R	R

LEGEND							
A	available (preferred)	A	available	R	on request	-	not available



INSTALLATION DRAWINGS

Size **72**

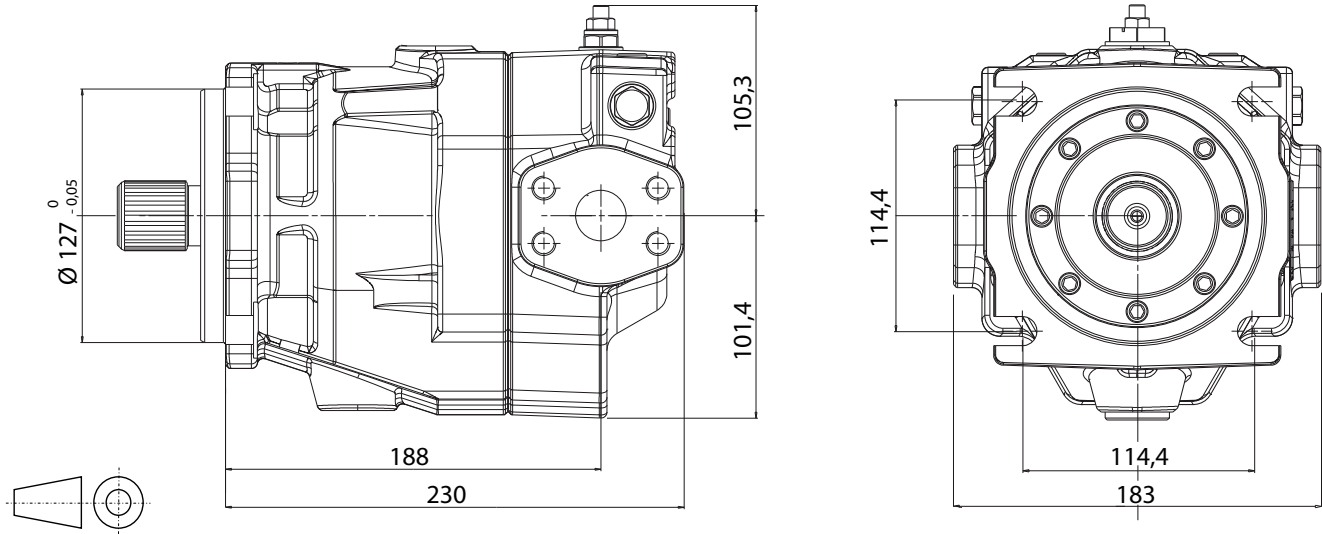

Ports

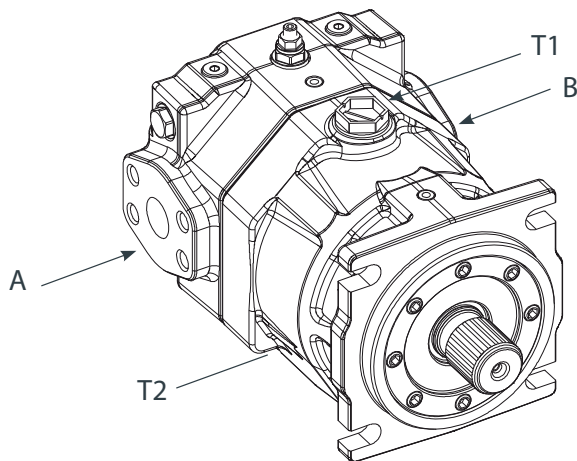

Detail Ports A-B

SAE J 518 - 1" - Code 62

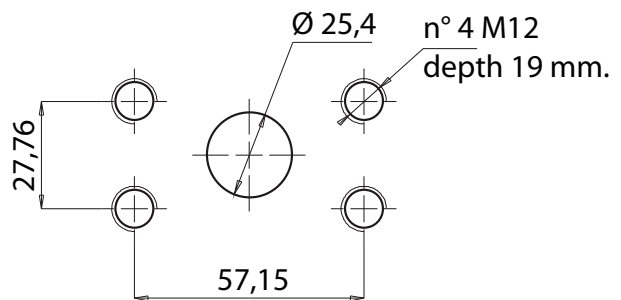

Port	Description	Standards	Size
A,B	High pressure ports	SAE flange J518-62	1"
T1, T2	Case drain ports	ISO 1179	3/4" BSP

Shaft End 21 N

ANSI B92.1A-1976 - 1"3/8 - 21 T - 16/32 DP

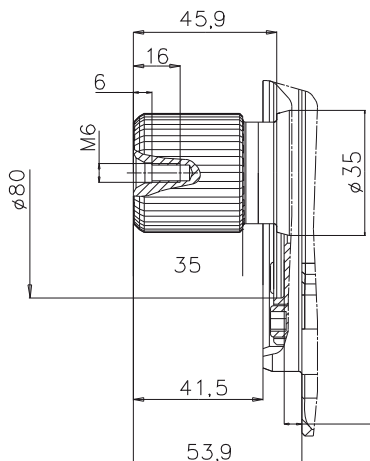

Mounting Flange C4

SAE J744 - Flange SAE C - 4 Bolts

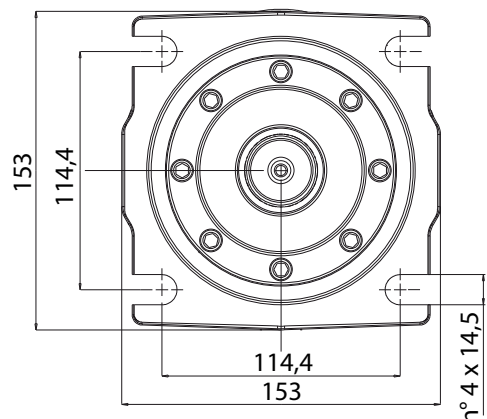

INSTALLATION DRAWINGS

Size 90 - 110

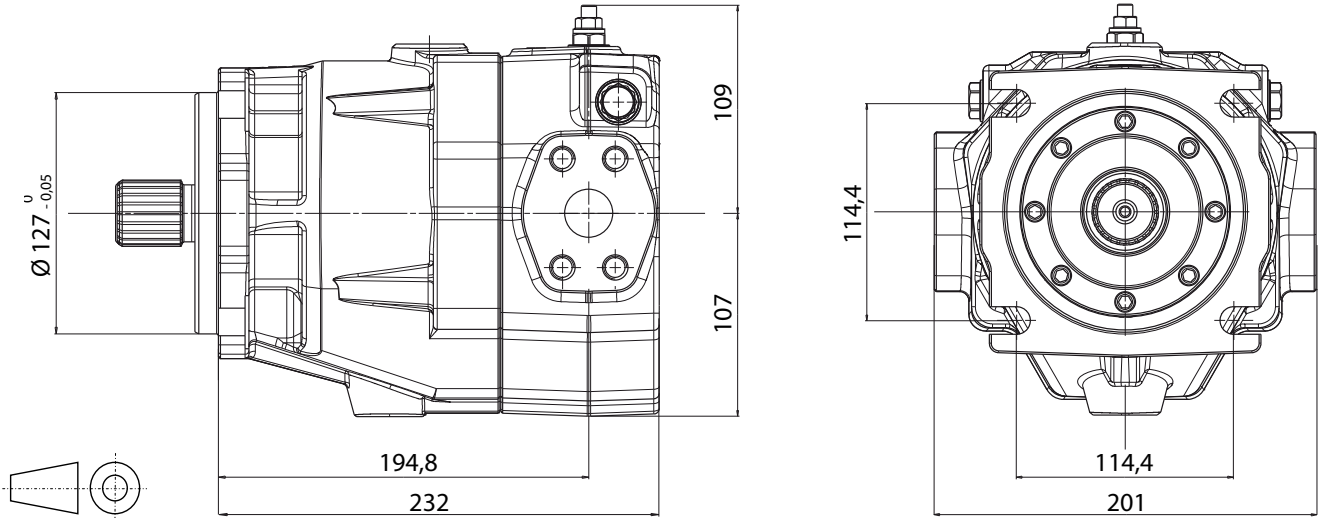

Ports

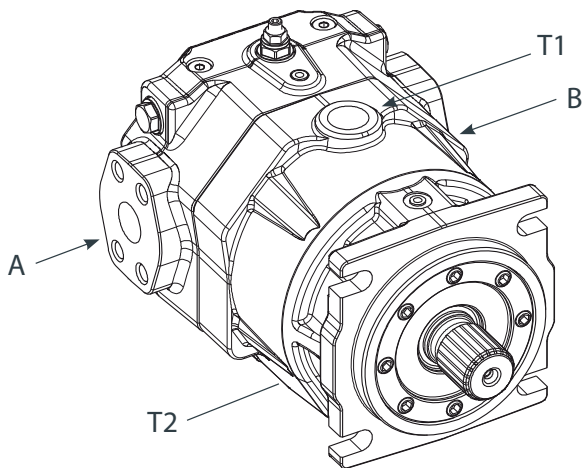

Detail Ports A-B

SAE J 518 - 1"- Code 62

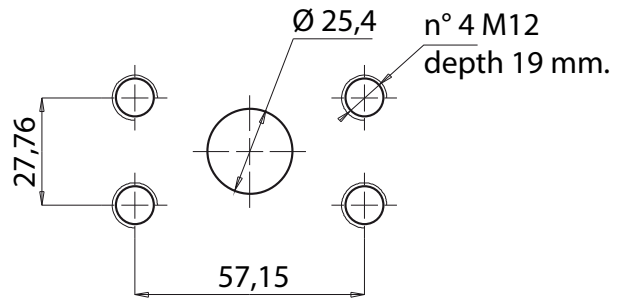

Port	Description	Standards	Size
A,B	High pressure ports	SAE flange J518-62	1"
T1, T2	Case drain ports	ISO 1179	3/4" BSP

Shaft End 21 N

ANSI B92.1A-1976 - 1"3/8 - 21 T - 16/32 DP

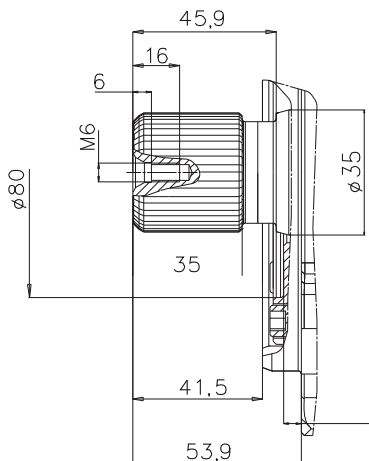

Mounting Flange C4

SAE J744 - Flange SAE C - 4 Bolts

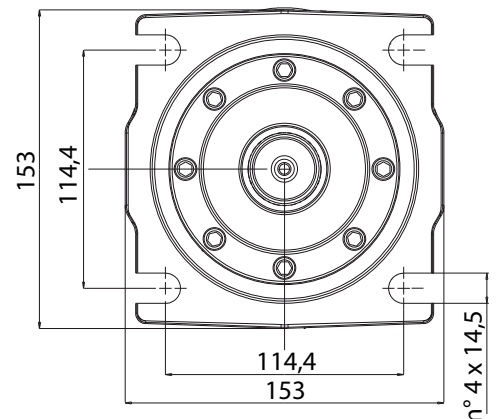

**DIRECTION of ROTATION - DIRECTION of the FLOW
Ports**

Flow direction through the motor		
Direction of rotation	R (CW)	B in to A out
	L (CCW)	A in to B out

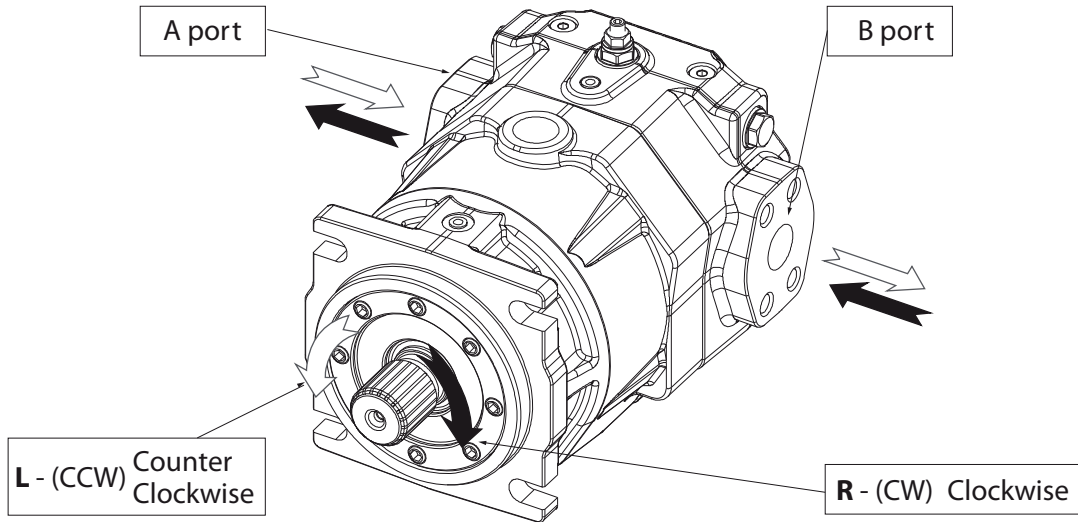

Flushing Valve

The motor is equipped with a flushing valve, integrated on the distributor of the motor that allows to direct a flow of oil from the low pressure channel inside the motor and later, through the discharge port, to a heat exchanger. This flow is restored by the anticavitation valve on the pump. The use of this valve allows dispose of excessive heat.

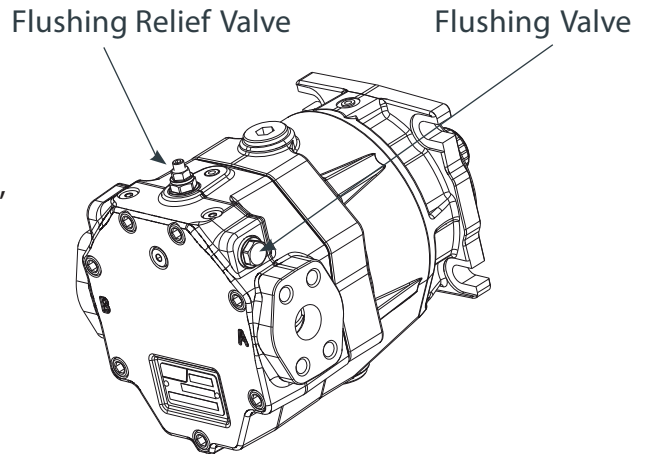

Hydraulic Diagram

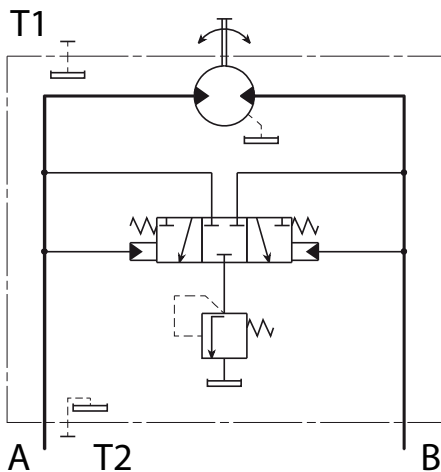

A, B	High pressure ports
T1, T2	Case Drain ports

INSTALLATION INSTRUCTION

Introduction

In the following pages are described the standards of installation of the motor. Compliance of the standards set has decisive effect on the life of the unit. The following illustration can identify the links for a correct installation. A standard requirement is that the motor must be filled with pre filtered hydraulic oil. The case must be filled with oil both in operation and during the break. The motor must be connected to the tank through the drain line. Lack of compliance with that condition can damage the unit irreparably.

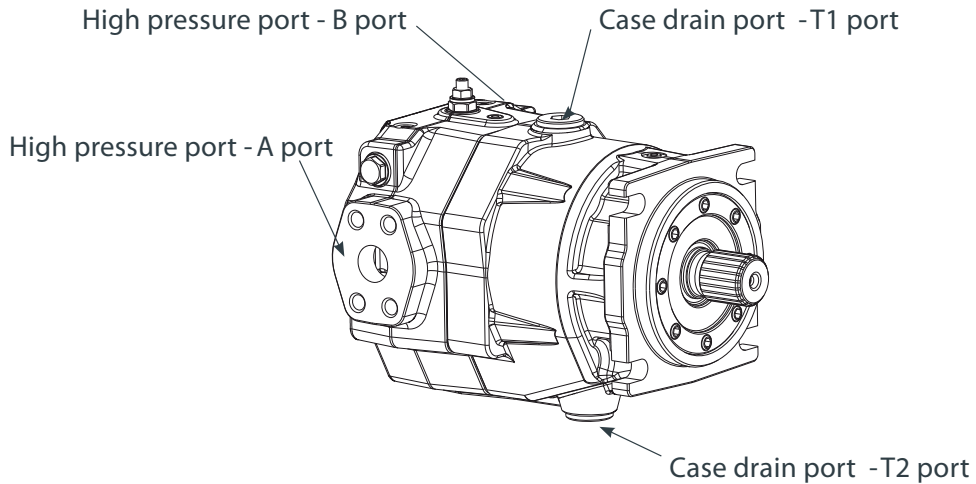

Installation Position

The case drain line must be always connected with the highest port. The motor can be installed in the following positions respect to the level of the tank of the hydraulic fluid:

	Motor Orientation	Notes
Under the tank		Standard Positioning
Above the tank		You must provide a non return valve on the case drain line to prevent the emptying of the line.

INSTALLATION INSTRUCTION

Motor Orientation

The motor can be oriented in the following positions:

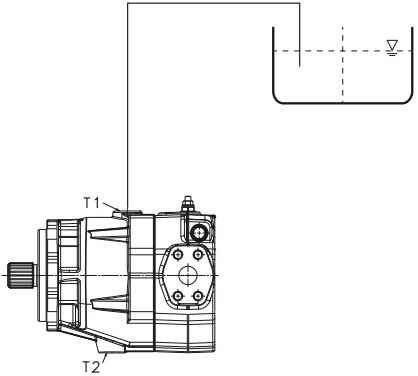
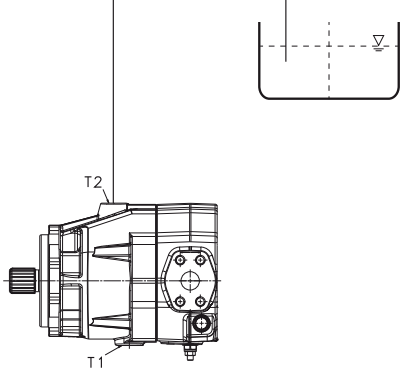
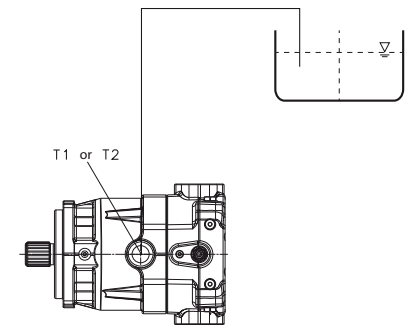
	Motor Orientation	Notes
<p>Horizontal shaft Service lines on side</p>		<p>The case drain line must be always connected with the highest port (T1)</p>
<p>Horizontal shaft Service lines on side</p>		<p>The case drain line must be always connected with the highest port (T2).</p>
<p>Horizontal shaft and Service lines on top and bottom</p>		<p>The case drain line must be always connected with the highest port (T1 or T2).</p>

As HANSA-TMP has a very extensive range of products and some products have a variety of applications, the information supplied may often only apply to specific situations.

If the catalogue does not supply all the information required, please contact HANSA-TMP.

In order to provide a comprehensive reply to queries we may require specific data regarding the proposed application.

Whilst every reasonable endeavour has been made to ensure accuracy, this publication cannot be considered to represent part of any contract, whether expressed or implied.

The data in this catalogue refer to the standard product. The policy of HANSA-TMP consists of a continuous improvement of its products. It reserves the right to change the specifications of the different products whenever necessary and without giving prior information.



**HYDRAULIC COMPONENTS
HYDROSTATIC TRANSMISSIONS
GEARBOXES - ACCESSORIES**

Via M. L. King, 6 - **41122 MODENA (ITALY)**
Tel: +39 059 415 711
Fax: +39 059 415 729 / 059 415 730
INTERNET: <http://www.hansatmp.it>
E-MAIL: hansatmp@hansatmp.it