

## Hydraulik-Handpumpen – Fusspedalpumpen Druckluftangetriebene Pumpen – Zubehör

## Hydraulic Hand Pumps – Foot Pedal Pumps Air-Hydraulic Pumps – Accessories



**GL**



**GLA**



**GL2 CN**

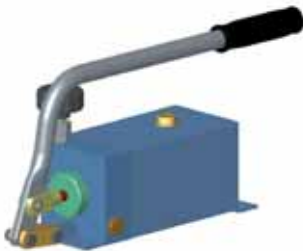

**GLDE**

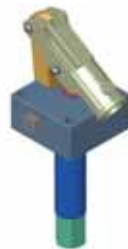

**GL 277**



**GL2P/Q**



**GLAPN**



**GTE**

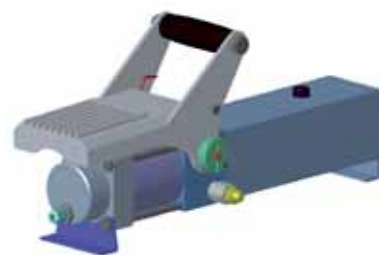

**GLOP**



Dieser Katalog ist herausgegeben von / *This catalogue is published by:*

**HANSA-TMP S.r.l.**  
**Via Martin Luther King, 6**  
**41122 Modena (MO)**  
**Italy**

Ausgabe Nr. / *Issue n°* **HT 20 / A / 310 / 0416 / DE** (ersetzt alle vorherigen Ausgaben) / *(Replaces all previous editions)*

KOPIEREN UND ÜBERSETZEN; AUCH TEILWEISE, NUR MIT SCHRIFTLICHER ERLAUBNIS DES HERAUSGEBERS GESTATTET. ALLE RECHTE VORBEHALTEN. UNTERLIEGT ÜBERARBEITUNGEN.  
*COPYING AND TRANSLATION, EVEN OF EXTRACTS, ONLY WITH PRIOR WRITTEN PERMISSION OF THE PUBLISHER. ALL RIGHTS RESERVED. SUBJECT TO REVISION.*

Die Datenangaben dienen allein der Produktbeschreibung und können nicht als garantierte Charakteristiken in gesetzlichem Sinne gewertet werden

*The specific data are for product description purposes only and must not be interpreted as warranted characteristics in legal sense.*

Konservierung: Aussenflächen standardmässig mit Lackierung RAL 5015 (blau), auf Flüssigbasis für die Modelle mit Tank; epoxy-pulverbeschichtet bei Modellen mit Gussgehäuse

*Protection: external protection is generally with painting RAL 5015 (Blue), on liquid base for models with tank, while epoxy powder for models with cast iron housing.*

Aluminiumteile sind anodisiert.

*Aluminium parts are anodized.*

Hebelteile und andere sind teilweise verzinkt.

*Lever parts and others are partially zinc-coated.*

Sonder-Schutzmöglichkeiten auf Anfrage.

*Special protection is possible on request*

**EINBAU, INBETRIEBNAHME UND WARTUNG DER IN DIESEM KATALOG BESCHRIEBENEN PRODUKTE:  
ASSEMBLY, COMMISSIONING AND MAINTENANCE OF THE PRODUCTS DESCRIBED IN THIS CATALOGUE:**

### **SIEHE HANDBUCH / SEE HANDBOOK**

Die meisten Funktionsdiagramme und Eigenschaftsangaben aus diesem Katalog basieren auf Prüfungen mit Hydraulik-Mineralöl ISO VG 46 mit Reinheitsklasse 17/15/12 ISO 4406 (Klasse 7 NAS 1638), bei Temperatur von +50°C.

*The main performance curves and the specifications shown in this catalogue are obtained by using mineral based fluid ISO VG 46, with cleanliness class of 17/15/12 ISO 4406 (Class 7 NAS 1638) at a temperature of 50°C.*

#### **HYDRAULISCHE DRUCKFLÜSSIGKEITEN / HYDRAULIC FLUIDS:**

*Allgemeine Eigenschaften / General properties:*

Die Druckflüssigkeit muss physisch-schmierende und chemisch geeignete Eigenschaften für Hydrauliksysteme haben, wie zum Beispiel:

*The fluid must have physical lubricating and chemical properties suitable for use in hydraulic systems, such as, for example:*

HYDRAULIK-MINERALÖLE HL ( DIN 51524 Teil 1)

*MINERAL OIL BASED HYDRAULIC FLUIDS HL (DIN 51524 part 1)*

HYDRAULIK-MINERALÖLE HLP (DIN 51524 Teil 2)

*MINERAL OIL BASED HYDRAULIC FLUIDS HLP (DIN 51524 part 2)*

Für den Betrieb mit anderen Druckflüssigkeiten, umweltfreundlichen oder nicht-entflammaren Flüssigkeiten ist technische Rückfrage erforderlich.

*For use of other fluids, environmentally friendly fluids or fire resistant fluids, please consult our Tech. Dept.*

## Anwendungen / Applications



Gully-Deckelheber  
*Culvert cover lifter*



Flugzeug-Wartungsgeräte  
*Aircraft ground support equipment*

Betonmischer  
*Concrete truck mixer*



Rahmenpressen  
*Furniture press*

## Anwendungen / Applications



Hydraulischer Anlasser für Schiffsdiesel  
*Hydraulic starter for marine diesel engine*



Spezielle Vorrichtungen für Behinderte  
*Special structures for disabled persons*

Hubvorrichtungen  
*All purpose platform*













Arbeits-Hebebühnen  
*Aerial platform*

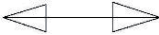

Windkraftanlagen  
*Wind power*





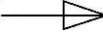

### Inhalt / Contents

Beschreibung <i>Description</i>	Pumpentype <i>Pump Type</i>	Seite <i>Page</i>
<p>Doppelhub-Pumpen mit Gussgehäuse, ohne Tank <i>Double acting pumps cast-iron housing without tank</i></p> 		<p>GL (20-45) 10 GL+GL4VN 11 GLD (20-45) 12 GLDV (20-45) 13 GLR (20-30) 14 GL189 15 GL218 16 GL310R 17 GL325 18</p>
<p>Doppelhub-Pumpen mit Gussgehäuse, mit Tank <i>Double acting pumps cast-iron housing with tank</i></p> 		<p>GLA (20-45) 19 GLB (20-30) 20 GL215-6-xx 21 GL215-10AL-xx 22</p>
<p>Doppelkolben- Doppelhub-Pumpen mit Gussgehäuse <i>Twin piston double acting cast-iron housing</i></p> 		<p>GL2C12-21N 23 GL2C12-21NR 24</p>
<p>Doppelhub-Pumpen mit Stahl-/Aluminiumgehäuse, ohne Tank <i>Double acting pumps steel/aluminium housing without tank</i></p> 		<p>GLDE20H-ALL 25 GLDE25H-ALL 26 GLNX 27 GLX 28 GL264 29 GL271R 30 GL277 31 GL290-SS 32 GL292-SS 33 GL303-ALL 34 GL315-xxx 35</p>
<p>Doppelhub-Pumpen mit Stahl-/Aluminiumgehäuse, mit Tank <i>Double acting pumps steel/aluminium housing with tank</i></p> 		<p>GL12NG 36 GLDE7AL 37 GLS(17-35)-S1-VMRM 38 GL170M 39 GL207 40 GL286 41 GLDE17-IN-60 42 GL290 43 GL290-4L 44 GL292 45 GL292-4L 46 PM22 47 PMS31AL 48</p>

## Inhalt / Contents

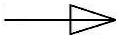
Beschreibung <i>Description</i>	Pumpentype <i>Pump Type</i>	Seite <i>Page</i>
Einfachhub-Pumpen, ohne Tank <i>Single acting pumps without tank</i> 		GL16ALL 49 GL111M 50 GL111M-750 51 GL246 52
Einfachhub-Pumpen, mit Tank <i>Single acting pumps with tank</i> 		GLSE16-ALL 53 GL1VAL 54 GL12DAL 55 GL12-1MAL 56 GL16Q 57 GL146-ALN 58 GL146-ALN-SC 59 GL226 60
Mehrkolben- Einfachhub- Pumpen <i>Single-acting multiple piston pumps</i> 		GL105-M2AL 61 GL105-M3 62 GL105-M4 63
2-Stufen-Pumpen <i>Two speed pumps</i> 		GL2P-RV(15-20)AL 64 GL2P-RV20AL-6LLV 65 GL2P-RV20AL-13LLV 66 GL2P-Q 67 GL2P-Q150 68 GL2P-Q+4VN 69 GL 2P-Q+4VN-VB 70 GL 2P70-(12-24)-A 71 GL 2P70-(12-24)-IA 72 GL2P70-AS 73 GL2P70-ASSTHA 74 GL241F3 75
Fusspedal-Pumpen <i>Foot pedal pumps</i> 		GLAPN (16-25) 76 GL100P 77 GL115MPAL 78 GL144PAL 79 GL219 80

### Inhalt / Contents

Beschreibung <i>Description</i>	Pumpentype <i>Pump Type</i>	Seite <i>Page</i>
Pumpen mit integriertem Zylinder <i>Pumps with built-in cylinder</i>   Heber und Abstützylinder <i>Jack and Stabilizing cylinder</i>		GL12C 81 GL21C40AL 82 GL24C 83 GLT10ALW 84 GTE (12-16) 85 GL224(P) 86 GL229(330) 87 GL239-HAL 88 GL243-C 89 GL247 90 GL249-RG 91 GL254AL 92 GL267 93 GL299-HAL 94 GL304 95 GLDE25-ICN 96
Druckluftangetriebene Pumpen <i>Air-Hydraulic pumps</i>		GLOP 6-8-10 97 GLOP 625-725 98
Ventile und Zubehör <i>Valves and Accessories</i>		GL4VN 99 RVM 100 R1V 100 VMP 101 VEM 101 D 102 DV 102



Symbol Doppelhub-Funktion / Double acting function symbol:

Der Hebel L muss vor- und zurück betätigt werden, um die angegebene Fördermenge (cm<sup>3</sup>) zu bekommen.  
 The lever L must be actuated forwards+backwards with force S, in order to obtain the shown displacement (cm<sup>3</sup>).



Symbol Einfachhub-Funktion / Single acting function symbol:

Der Hebel L (oder das Pedal) muss nur in einer Richtung mit dem Kraftaufwand S betätigt werden, um die angegebene Fördermenge (cm<sup>3</sup>) zu bekommen.  
 The lever (or the foot lever) L must be actuated in only one direction with force S, in order to obtain the shown displacement (cm<sup>3</sup>).



### Hydraulik-Handpumpen Bauserie GL - GL Hydraulic Hand Pumps

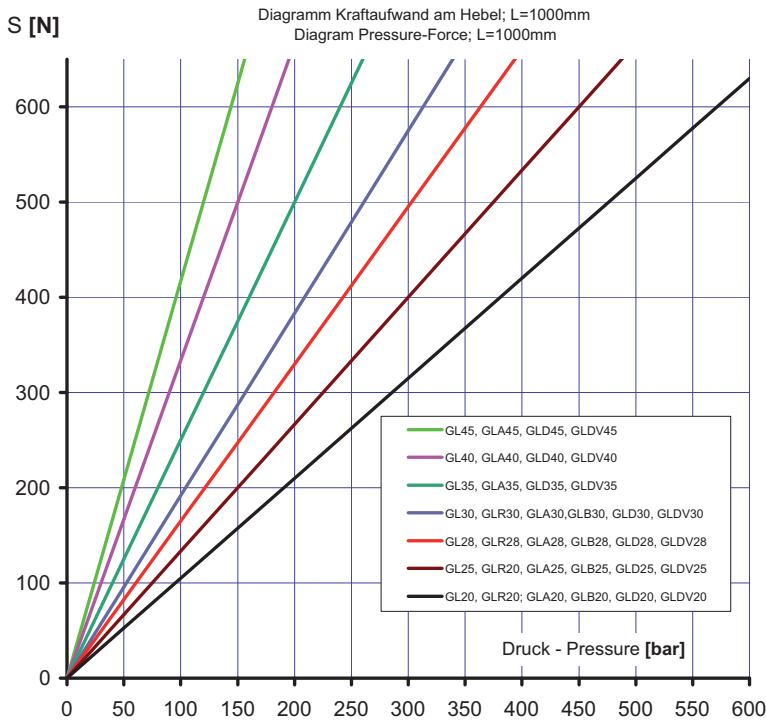

Die Handpumpen der Bauserie GL werden auf modernsten CNC-Fertigungsmaschinen hergestellt und mit Verwendung besonders ausgesuchter Materialien. Dank der Fertigung in grossen Serien und der genauen Qualitätskontrollen steht diese Produktbaureihe heute an der Weltspitze dieses Gebietes.

Der Einsatz erfolgt in vielen Bereichen der Hydraulik: als Hauptpumpe im Hochdruckbereich, auf Prüfvorrichtungen, als Notpumpe im Industrie- und Mobilbereich, auf Werkstattvorrichtungen, Rettungsgeräten, in der Spannhydraulik, im Energiebereich.

The hand-pumps of the GL-series are manufactured on most modern CNC-machines and by using accurately selected raw materials. The production in large series and the highest quality controls confirm them on the highest world level for products of this type of construction. Their application is in various fields: as emergency or auxiliary pump in mobile or industrial hydraulics; as main pump in the high pressure technology for: material testing; hoisting; levelling; block-technology; cutting machines; presses, etc.

Umrechnungstabelle Conversion Table
1mm * 10 <sup>-3</sup> = 1m
1kg * 9.81 = 1N
1bar * 10 <sup>-5</sup> = 1N/m <sup>2</sup> (pa)
1L * 10 <sup>-3</sup> = 1m <sup>3</sup>
1cm <sup>3</sup> /A * 10 <sup>-6</sup> = 1m <sup>3</sup> /A
1mm * 0.039 = 1in
1kg * 0.457 = 1lb
1bar * 14.286 = 1psi
1L * 0.061 = 1in <sup>3</sup>
1cm <sup>3</sup> /A * 0.061 = 1in <sup>3</sup> /A
A = Funktionszyklus - Cycle

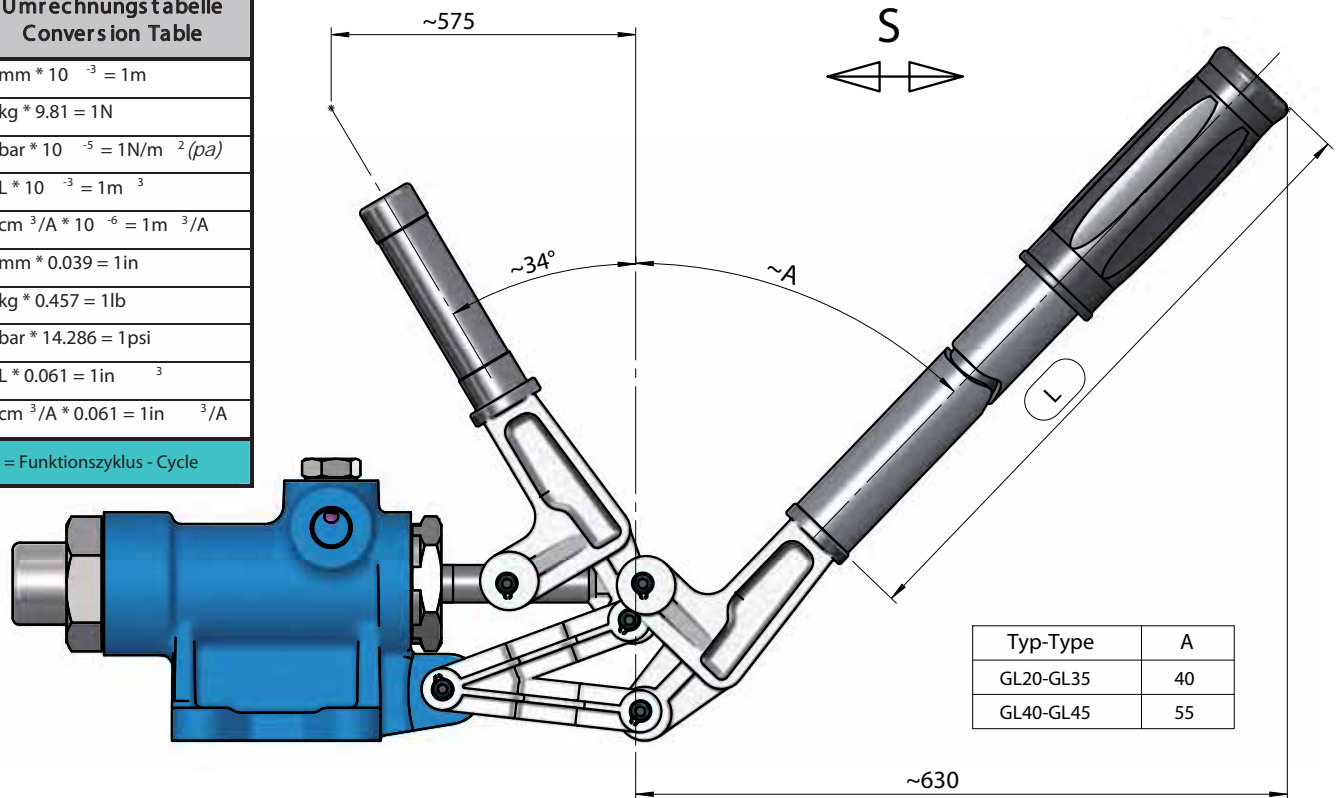

Typ-Type	A
GL20-GL35	40
GL40-GL45	55

Die Handpumpen sind für den Einsatz mit Hydraulik-Mineralöl ausgelegt (z. B. Nuto H32 oder gleichwertig).  
Für den Einsatz mit anderen Druckflüssigkeiten sind besondere Dichtungsmaterialien möglich.  
Our hand-pumps work only with hydraulic oil. (f. in . Nuto H32 or equivalent). Different special hydraulic oil could need special gaskets .

### Pumpe Typ GL - Pump Type GL

*Doppelhubfunktion für einfachwirkende Zylinder*  
*Double-stroke function for single acting cylinder*

Einbaulage - Mounting:  
uneingeschränkt.  
Any position.

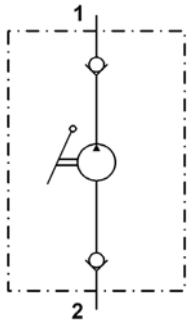

Gewicht - Weight  
5,3-6,5[kg]

1 Druckanschluss - Pressure port  
2 Sauganschluss - Suction port

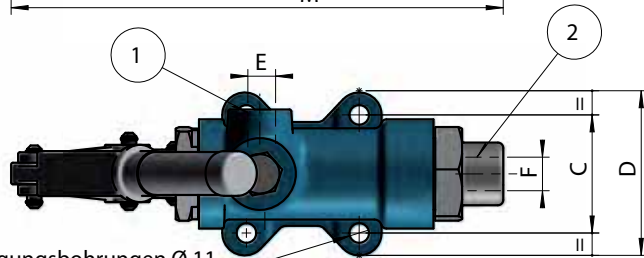
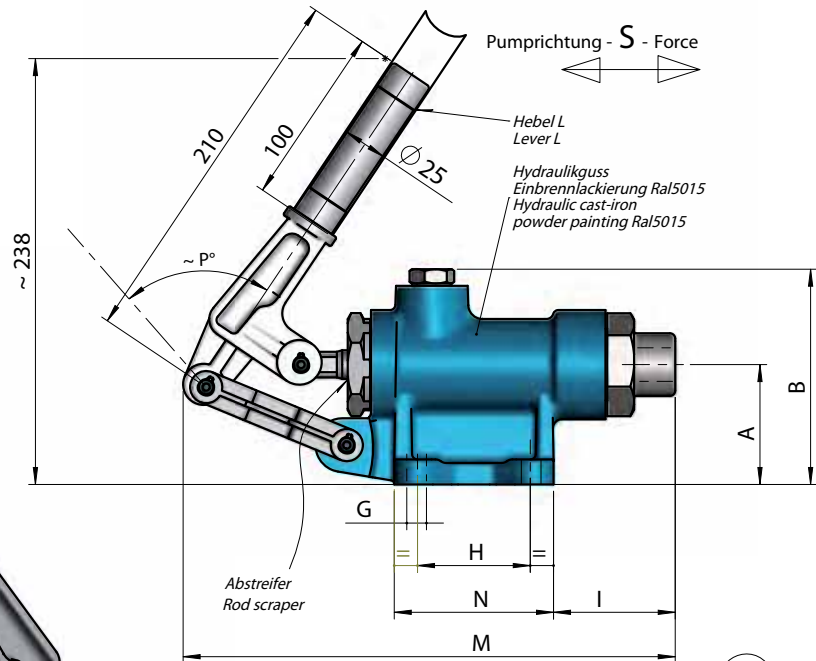
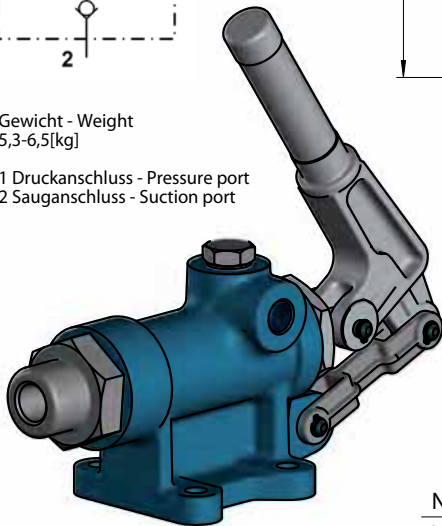

N°4 Befestigungsbohrungen Ø 11  
N°4 holes Ø 11

\* Zulassung Handelsmarine  
Ministerialdekret 47/1988 und 48/1988  
R.I.N.A. - Zulassung 17874

\* Authorized by the Italian Ministry of Mercantile Marine  
with Nr. 47/1988 and 48/1988 - Authorized Italian  
Navy Register (RINA) Nr. 17874

TYP TYPE	Fördervolumen Displacement [cm³]	Druck Pressure [bar]
GL20	18	650
GL25*	29	320
GL28	36	250
GL30	42	220
GL35*	57	160
GL40	87	120
GL45	111	90

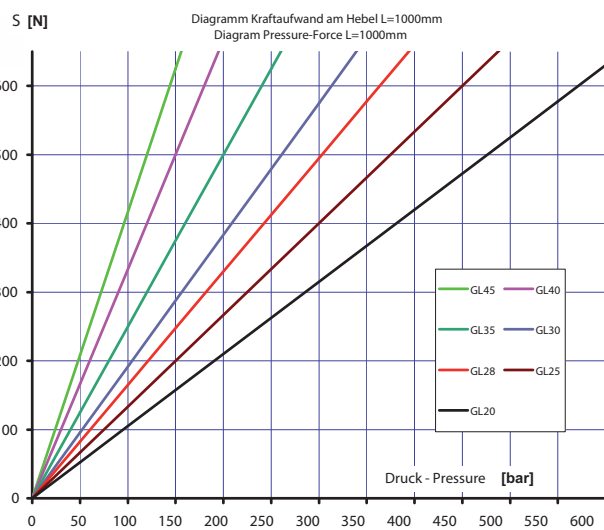

Typ - Type	A	B	C	D	E	F	G	H	I	M	N	P
GL20-25-28-30-35	67	120	66	95	3/8" gas	1/2" gas	11	63	68	285	89	75
GL40-45	71	137	71	102	1/2" gas	1/2" gas	11	73	71	295	104	90

Unverbindliche Angaben. Änderungen vorbehalten. - Dimensions not binding. Modifications reserved without prior notice.  
Property of HANSA-TMP SRL. Copying without authorisation will be persecuted by Law.  
Eigentum von HANSA-TMP SRL. Nicht genehmigtes Kopieren wird strafrechtlich verfolgt.

### Pumpe Typ GL+GL4VN - Pump Type GL+GL4VN

*Doppelhubfunktion mit Umschaltventil für doppelwirkende Zylinder*  
*Double-stroke function with diverter for double acting cylinder*

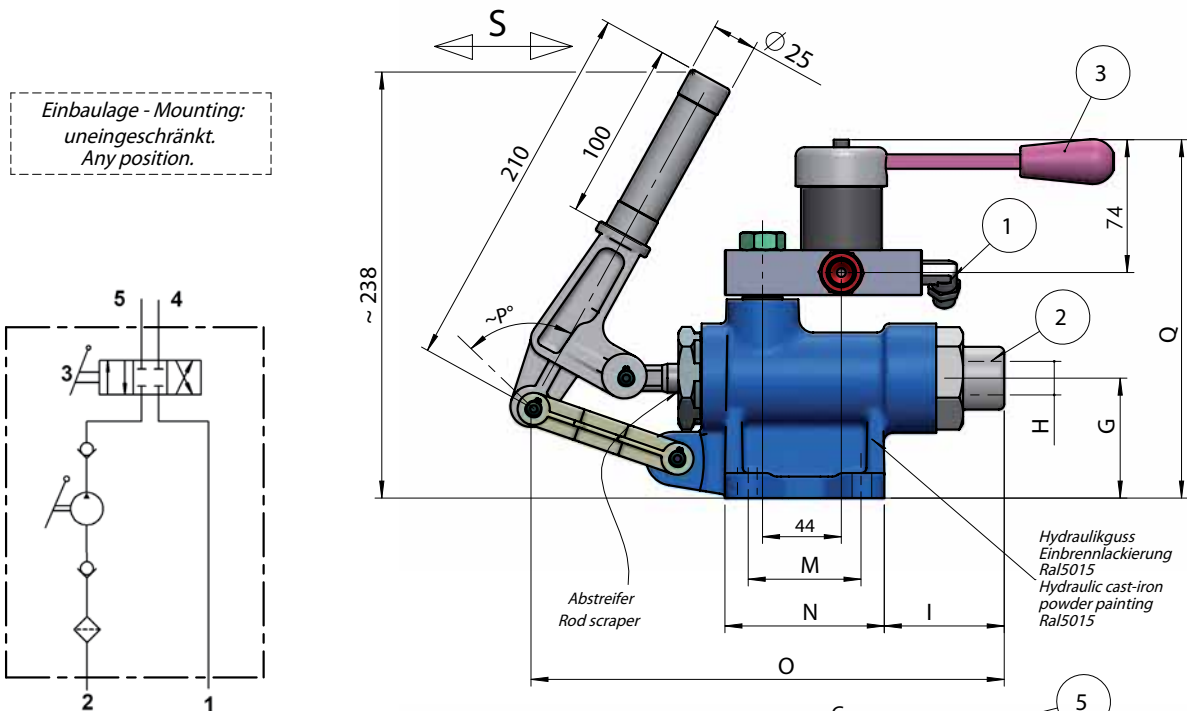

Gewicht - Weight = 6,3 - 7,5 [kg]

- 1 Ölrücklauf - Oil discharge
- 2 Sauganschluss - Suction port
- 3 Umschaltventil - Inverter lever
- 4 Druckanschluss - Pressure port
- 5 Druckanschluss - Pressure port

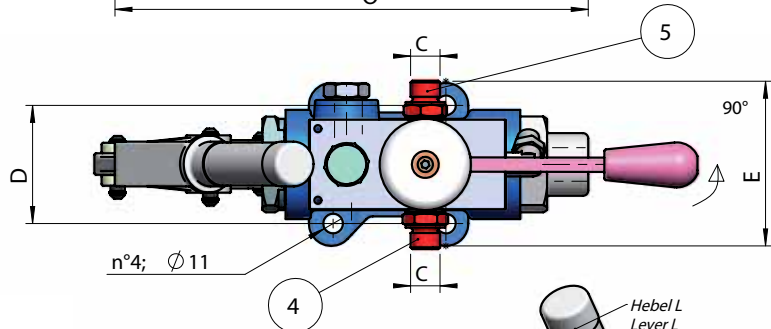

TYP TYPE	Fördervolumen Displacement [cm <sup>3</sup> ]	Druck Pressure [bar]
GL20+GL4VN	18	600
GL25+GL4VN	29	320
GL28+GL4VN	36	250
GL30+GL4VN	42	220
GL35+GL4VN	57	160
GL40+GL4VN	87	120
GL45+GL4VN	111	90

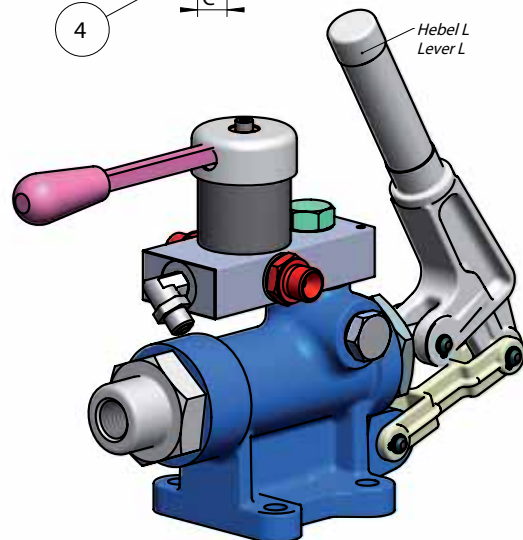

TYP - TYPE	A	B	C	D	E	F	G	H	I	M	N	O	P	Q
GL(20-25-28-30-35)+GL4VN	90	90	3/8" gas	66	95	50	67	1/2" gas	68	63	89	285	75	195
GL(40-45)+GL4VN	100	107	3/8" gas	71	102	54	71	1/2" gas	71	73	104	295	90	210

*Unverbindliche Angaben. Änderungen vorbehalten. - Dimensions not binding. Modifications reserved without prior notice.  
Property of HANSA-TMP SRL. Copying without authorisation will be persecuted by Law.  
Eigentum von HANSA-TMP SRL. Nicht genehmigtes Kopieren wird strafrechtlich verfolgt.*

### Pumpe Typ GLD - Pump Type GLD

Doppelhubfunktion mit Ablassventil für einfachwirkenden Zylinder  
Double-stroke with release handknob for single acting cylinder

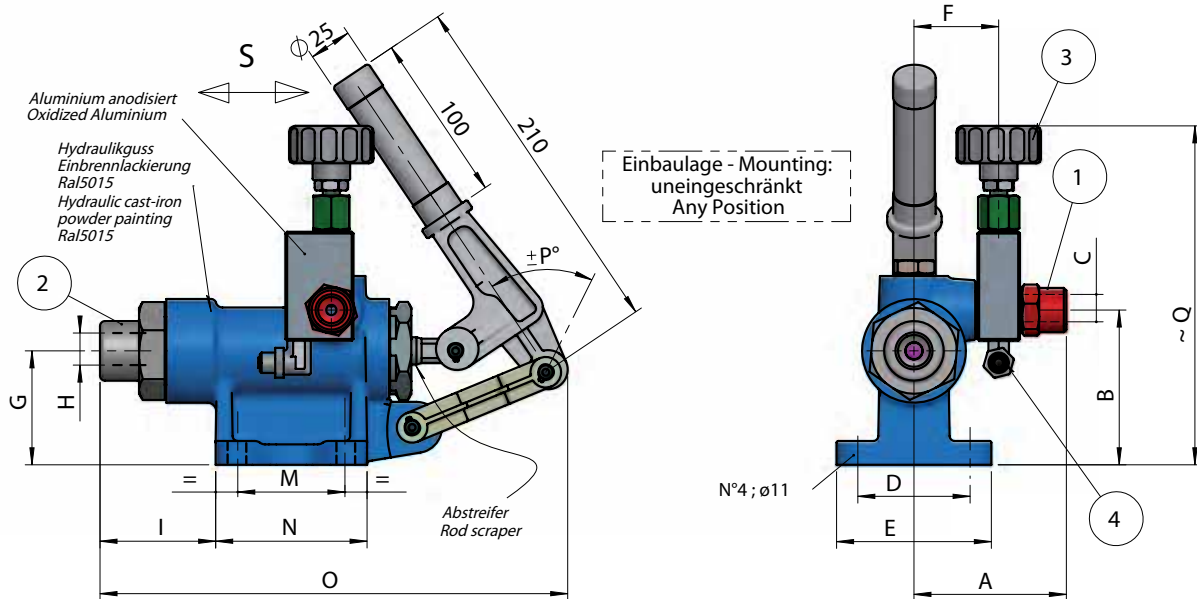

Gewicht - Weight = 6.3 - 7 [kg]

- 1 Druckanschluss - Pressure port
- 2 Sauganschluss - Suction port
- 3 Ablasshandrad - Release handknob
- 4 für Rücklaufschlauch ø8 - Discharge, pipe ø8

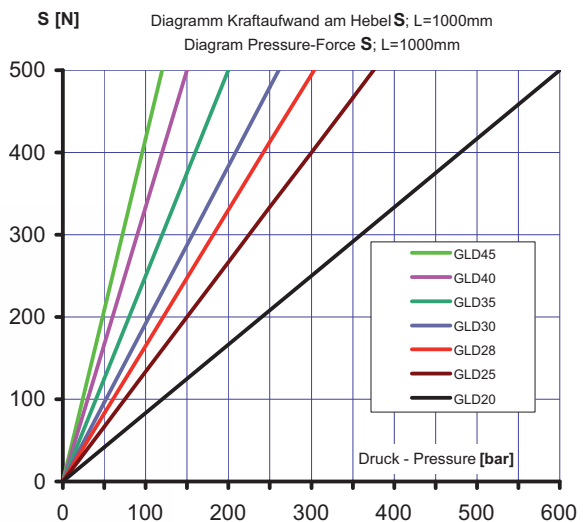
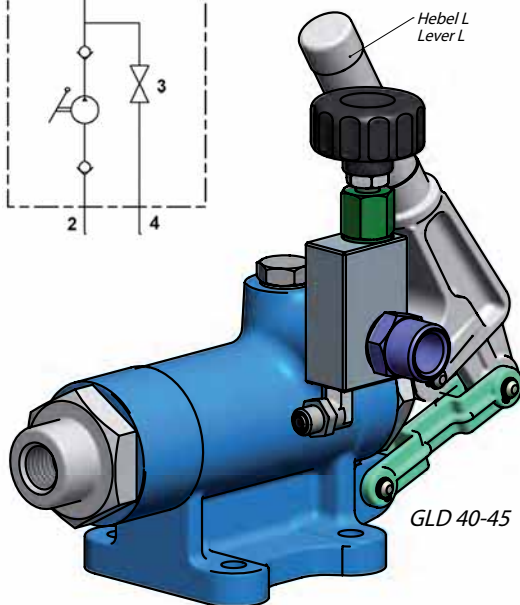
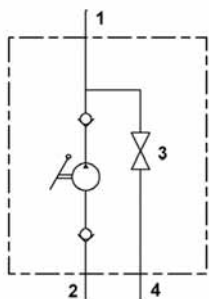

TYP TYPE	Fördervolumen Displacement [cm <sup>3</sup> ]	Druck Pressure [bar]
GLD20	18	460
GLD25	29	320
GLD28	36	250
GLD30	42	220
GLD35	57	160
GLD40	87	120
GLD45	111	90

TYP - TYPE	A	B	C	D	E	F	G	H	I	M	N	O	P	Q
GLD 20-25-28-30-35	90	90	3/8" gas	66	95	50	67	1/2" gas	68	63	89	285	75	195
GLD 40-45	100	107	1/2" gas	71	102	54	71	1/2" gas	71	73	104	295	90	210

Unverbindliche Angaben. Änderungen vorbehalten. - Dimensions not binding. Modifications reserved without prior notice.  
Property of HANSA-TMP SRL. Copying without authorisation will be persecuted by Law.  
Eigentum von HANSA-TMP SRL. Nicht genehmigtes Kopieren wird strafrechtlich verfolgt.

### Pumpe Typ GLDV - Pump Type GLDV

*Doppelhubfunktion mit Druckbegrenzung für einfachwirkenden Zylinder*  
*Double-stroke with relief valve for single acting cylinder*

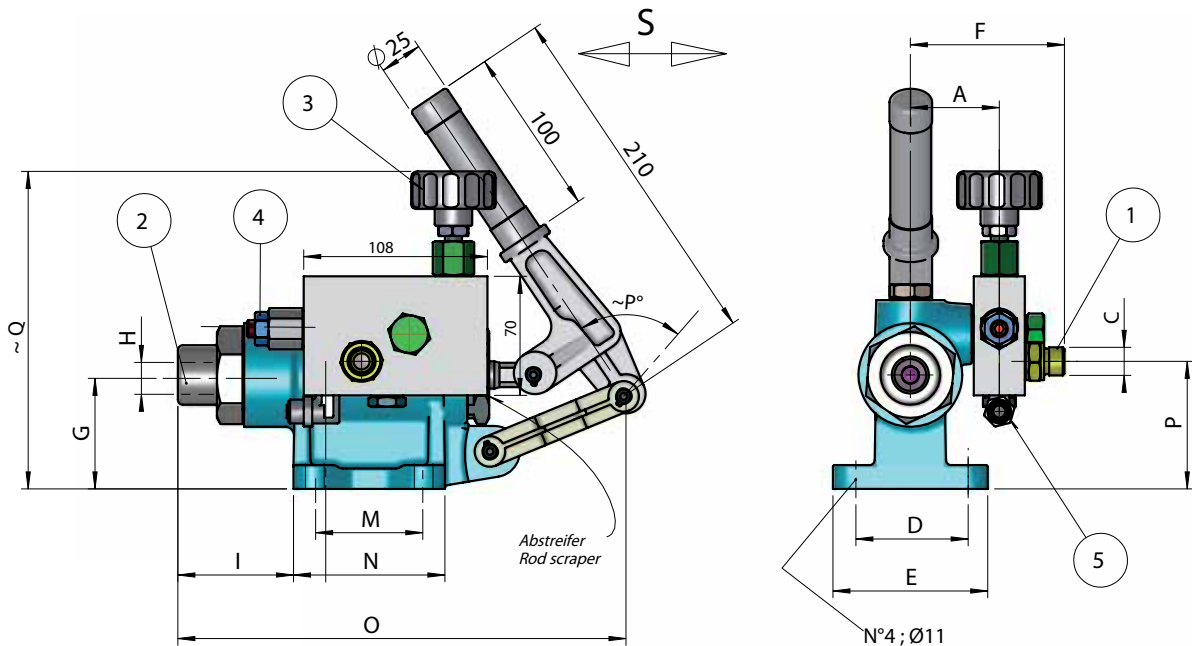

Gewicht - Weight = 6.7-8 [kg]

- 1 Druckanschluss  
Pressure Port
- 2 Sauganschluss  
Suction Port
- 3 Ablasshandrad  
Release handknob
- 4 Max-Druckeinstellung  
Relief Valve
- 5 Rücklauf zum Tank (für Schlauch Durchm. 8)  
Tank port (for pipe ø8)

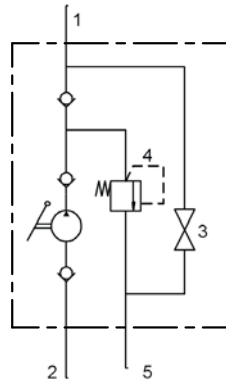

*Einbaulage - Mounting:  
uneingeschränkt.  
Any position.*

TYP TYPE	Fördervolumen Displacement [cm <sup>3</sup> ]	Druck Pressure [bar]
GLDV20	18	460
GLDV25	29	320
GLDV28	36	250
GLDV30	42	220
GLDV35	57	160
GLDV40	87	120
GLDV45	111	90

Hebel L  
Lever L

Hydraulikguss  
Einbrennlackierung Ral5015  
Hydraulic cast-iron  
powder painting Ral5015

Aluminium anodisiert  
Oxidized Aluminium

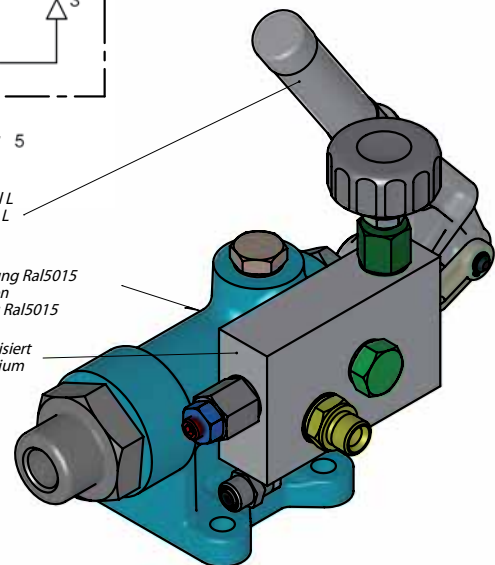

TYP-TYPE	A	B	C	D	E	F	G	H	I	M	N	O	P	Q
GLDV 20-25-28-30-35	90	90	3/8" gas	66	95	50	67	1/2" gas	68	63	89	285	75	188
GLDV 40-45	100	107	3/8" gas	71	102	54	71	1/2" gas	71	73	104	295	90	203

*Unverbindliche Angaben. Änderungen vorbehalten. - Dimensions not binding. Modifications reserved without prior notice.*  
*Property of HANSA-TMP SRL. Copying without authorisation will be persecuted by Law.*  
*Eigentum von HANSA-TMP SRL. Nicht genehmigtes Kopieren wird strafrechtlich verfolgt.*

### Pumpe Typ GLR - Pump Type GLR

*Doppelhubfunktion für einfachwirkende Zylinder*  
*Double-stroke function for single acting cylinder*

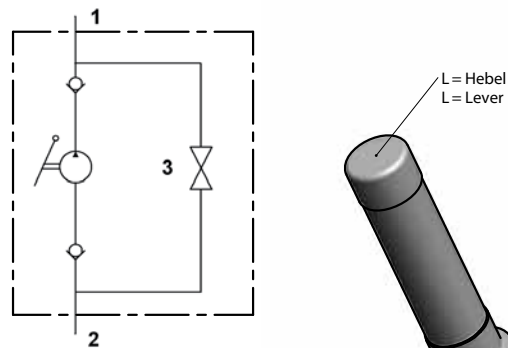
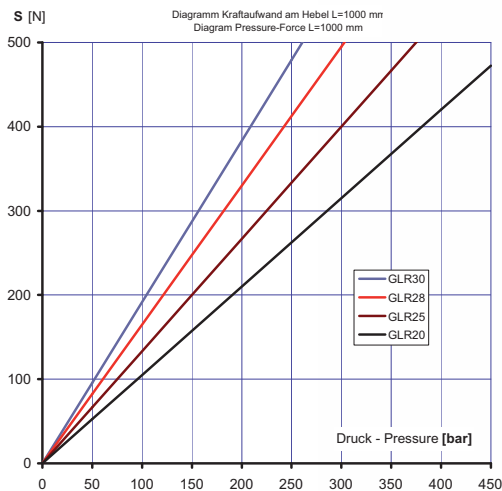
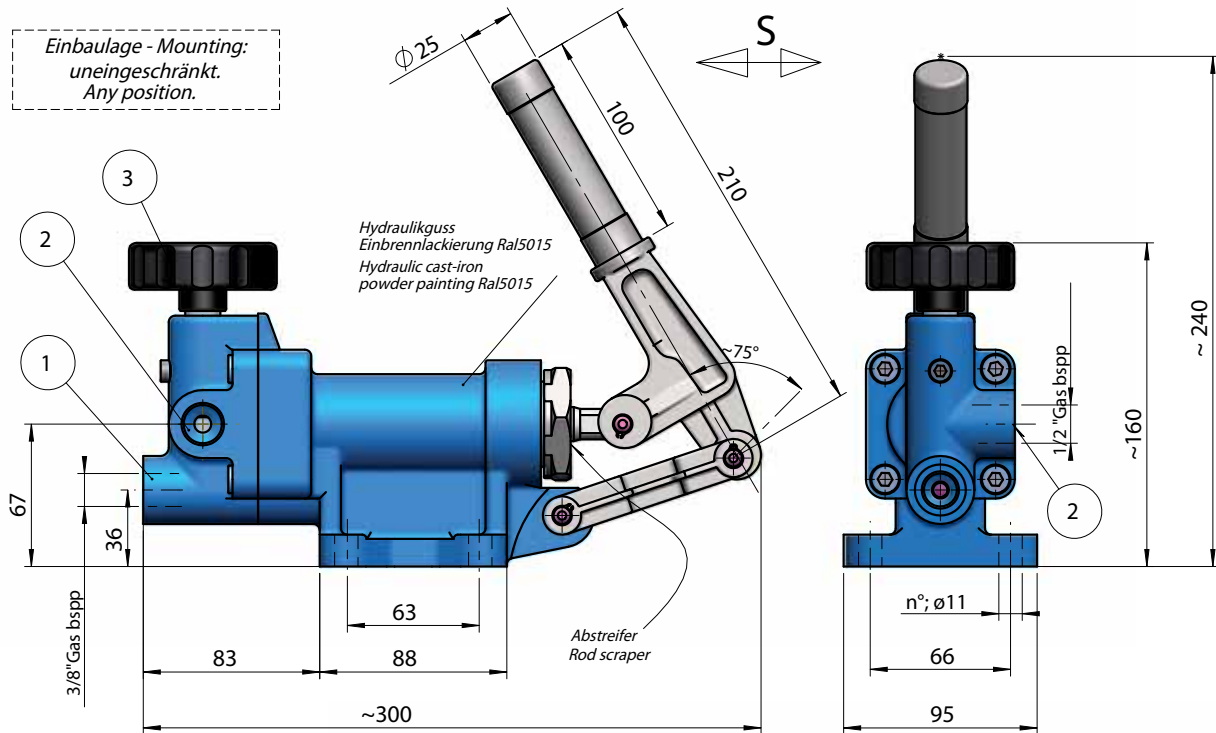

Gewicht - Weight ~6,3 - 6,5 [kg]

- 1 Druckanschluss - Pressure port
- 2 Sauganschluss - Suction port
- 3 Ablasshandrad - Release handknob

TYP TYPE	Fördervolumen Displacement [cm³]	Druck Pressure [bar]
GLR20	18	460
GLR25	29	320
GLR28	36	250
GLR30	42	220

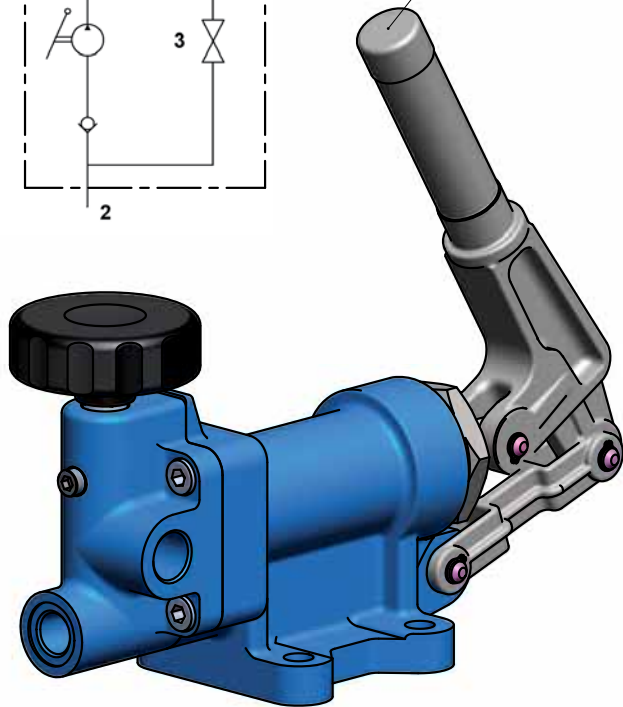

Unverbindliche Angaben. Änderungen vorbehalten. - Dimensions not binding. Modifications reserved without prior notice.  
Property of HANSA-TMP SRL. Copying without authorisation will be persecuted by Law.  
Eigentum von HANSA-TMP SRL. Nicht genehmigtes Kopieren wird strafrechtlich verfolgt.

### Pumpe Typ GL189 - Pump Type GL189

*Pumpe Typ GL + Baugruppe D. Doppelhubfunktion für einfachwirkenden Zylinder*  
*Pump type GL + Group D. Double-stroke function for single acting cylinder*

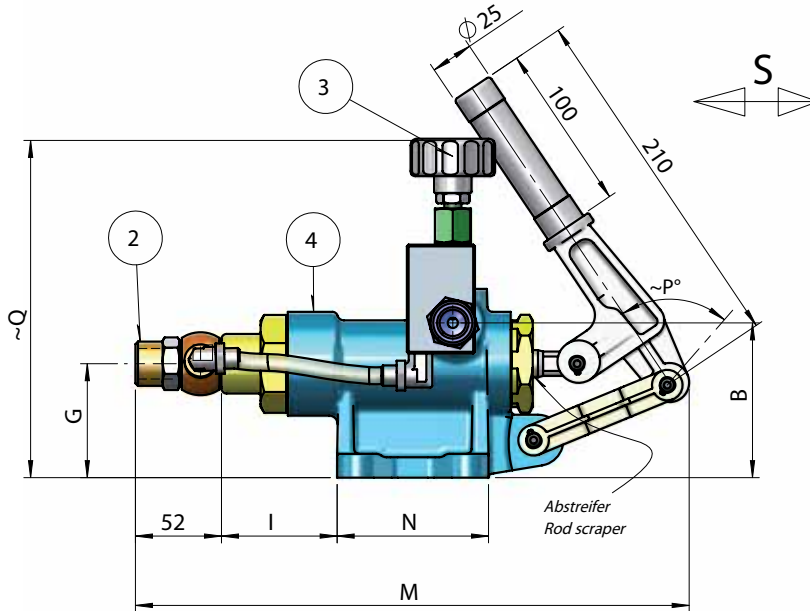

Einbaulage - Mounting:  
uneingeschränkt.  
Any position.

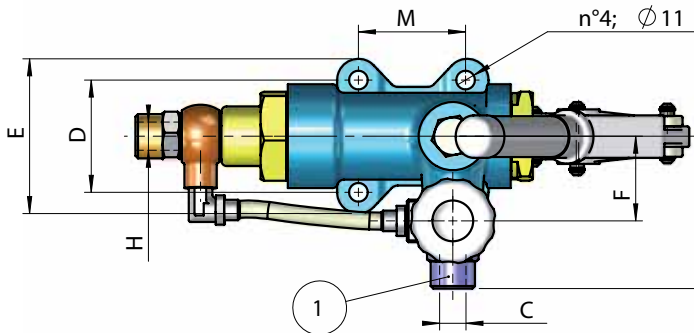
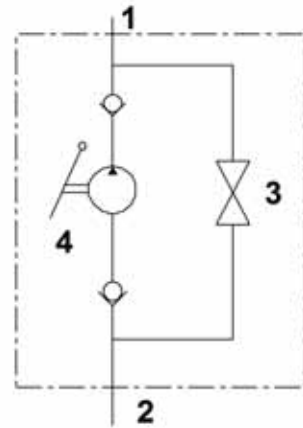

Gewicht - Weight ~ 6.5-7.5 [kg]

- 1 Druckanschluss - Pressure port
- 2 Sauganschluss - Suction port
- 3 Ablasshandrad - Release Handknob
- 4 Pumpe Typ GL20-45 Pump type GL20-45

TYP TYPE	Fördervolumen Displacement [cm³]	Druck Pressure [bar]
GL189-20	18	460
GL189-25	29	320
GL189-28	36	250
GL189-30	42	220
GL189-35	57	160
GL189-40	87	120
GL189-45	111	90

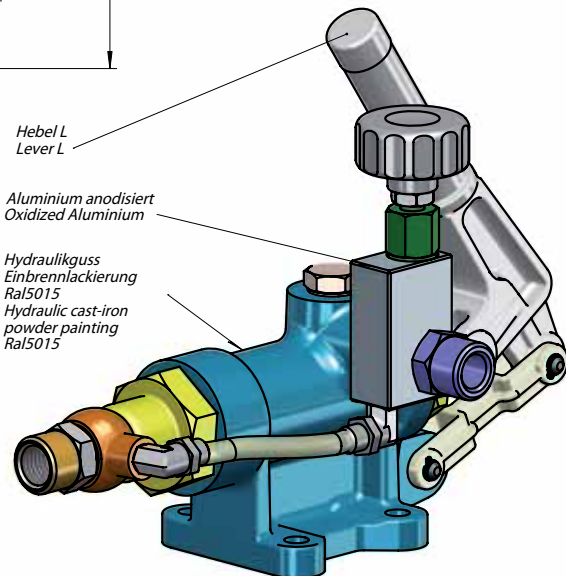

TYP - TYPE	A	B	C	D	E	F	G	H	I	M	N	O	P	Q
GL189-(20-25-28-30-35)	90	90	3/8" gas	66	95	50	67	1/2" gas	68	63	89	285	75	195
GL189-(40-45)	100	107	1/2" gas	71	102	54	71	1/2" gas	71	73	104	295	90	210

*Unverbindliche Angaben. Änderungen vorbehalten. - Dimensions not binding. Modifications reserved without prior notice.*  
*Property of HANSA-TMP SRL. Copying without authorisation will be persecuted by Law.*  
*Eigentum von HANSA-TMP SRL. Nicht genehmigtes Kopieren wird strafrechtlich verfolgt.*

### Pumpe Typ GL218 - Pump Type GL218

*Doppelhubfunktion mit Druckbegrenzung für einfachwirkenden Zylinder*  
*Double-stroke with relief valve for single acting cylinder*

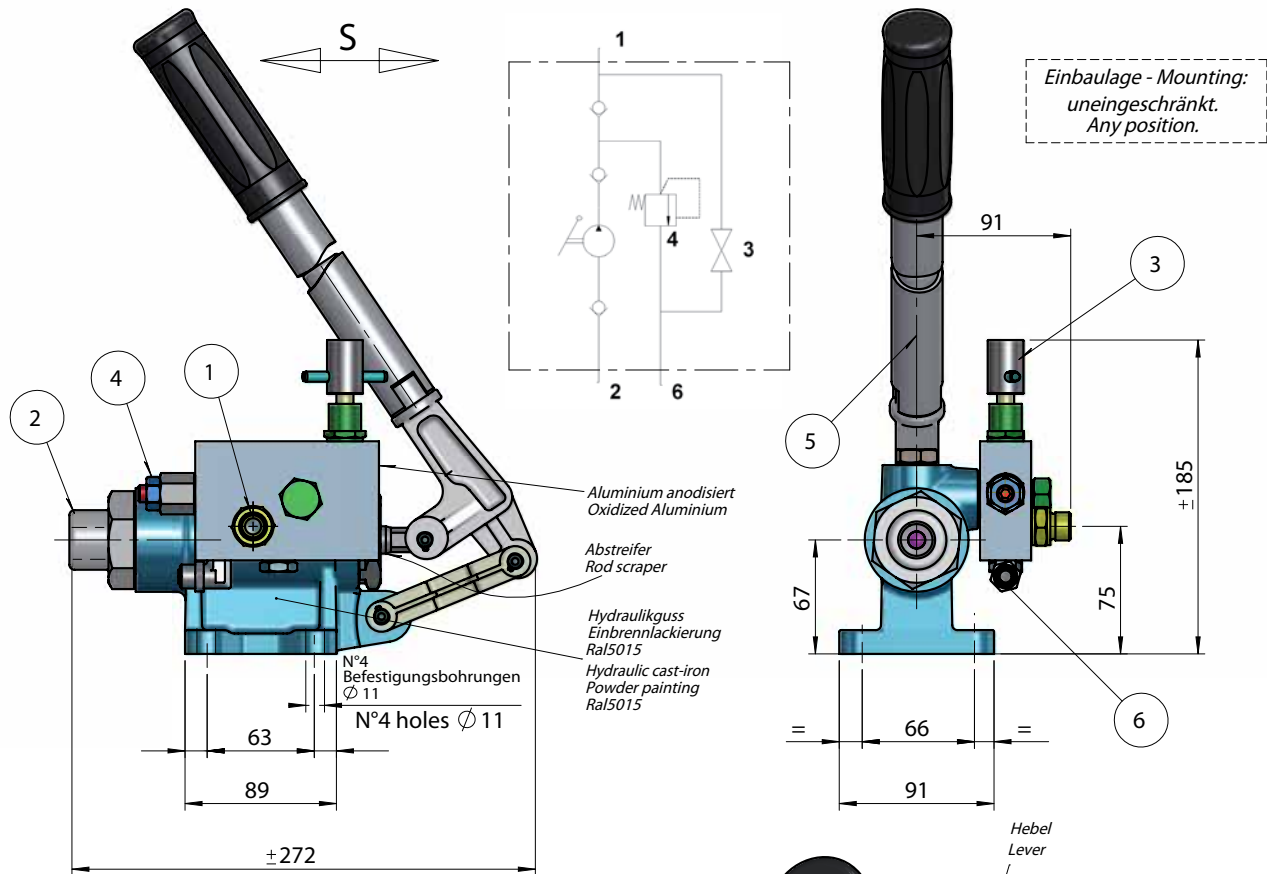

Gewicht - Weight ~6.7-8 [kg]

- 1 Druckanschluss 3/8" Gas bssp - Pressure Port 3/8" Gas bssp
- 2 Sauganschluss 1/2" Gas bssp - Suction Port 1/2" Gas bssp
- 3 Ablasshandrad - Release handknob
- 4 Max-Druckeinstellung - Relief valve
- 5 Pumphebel - Action Lever
- 6 Rücklaufanschluss (für Schlauch Durchm. 8) - Tank Port (for pipe ø8)

TYP TYPE	Fördervolumen Displacement [cm³]	Druck Pressure [bar]
GL218-20	18	460
GL218-25	29	320
GL218-28	36	250
GL218-30	42	220
GL218-35	57	160

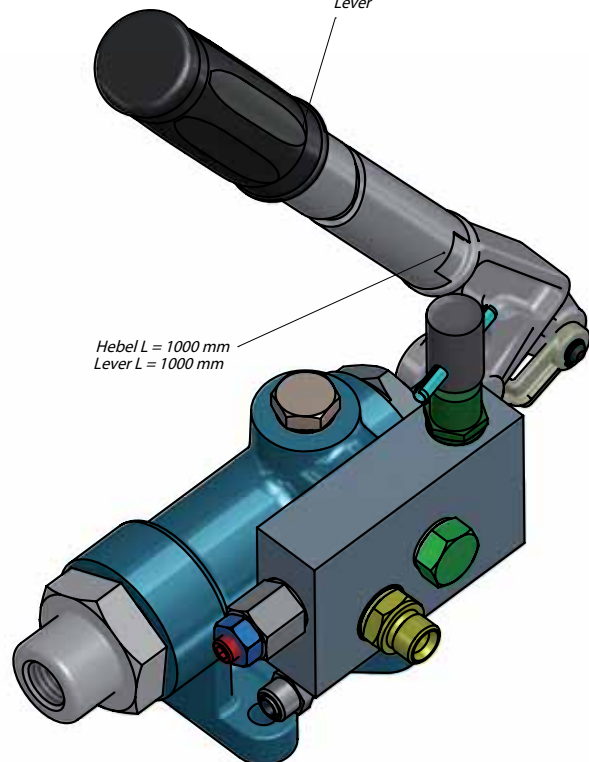

*Unverbindliche Angaben. Änderungen vorbehalten. - Dimensions not binding. Modifications reserved without prior notice.*  
*Property of HANSA-TMP SRL. Copying without authorisation will be persecuted by Law.*  
*Eigentum von HANSA-TMP SRL. Nicht genehmigtes Kopieren wird strafrechtlich verfolgt.*



### Pumpe Typ GL310R-20 - Pump Type GL310R-20

*Doppelhubfunktion für einfachwirkende Zylinder*  
*Double-stroke function for single acting cylinder*

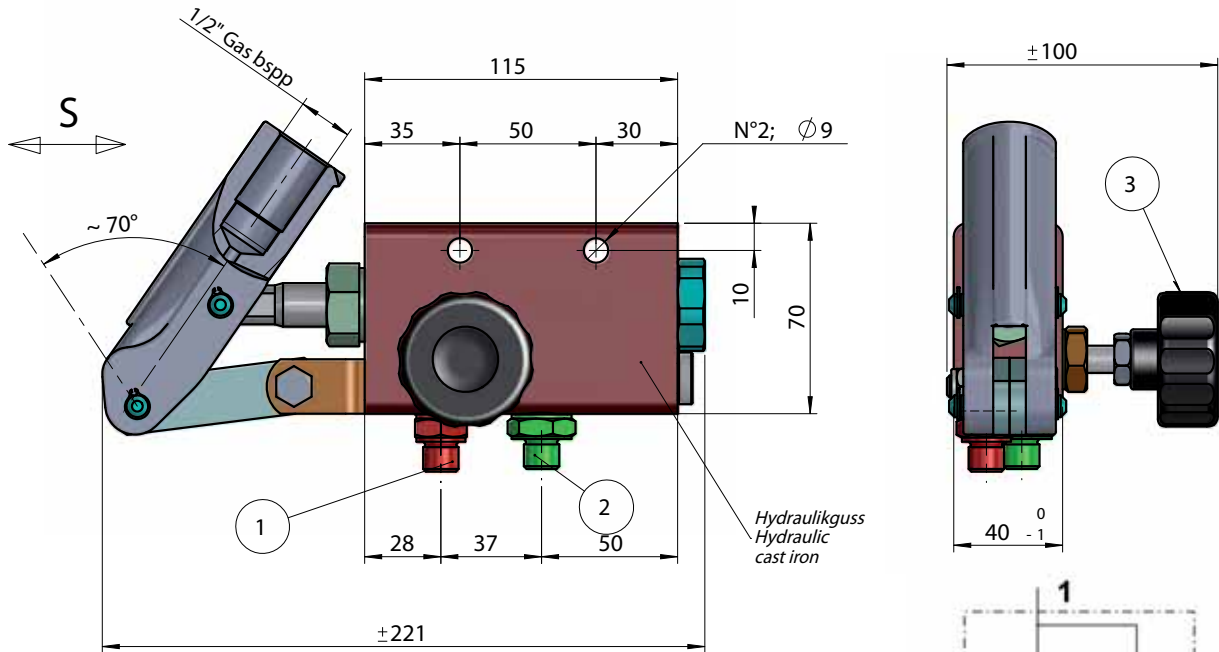

Gewicht (mit Hebel L=530 mm) ~4[kg] -  
Weight (with extension lever L=530 mm) ~4[kg]

- 1 Druckanschluss 1/4" Gas bspp  
Pressure Port 1/4" Gas bspp
- 2 Sauganschluss 1/4" Gas bspp  
Suction Port 1/4" Gas bspp
- 3 Ablasshandrad -  
Release handknob

*Einbaulage - Mounting:  
uneingeschränkt  
Any position*

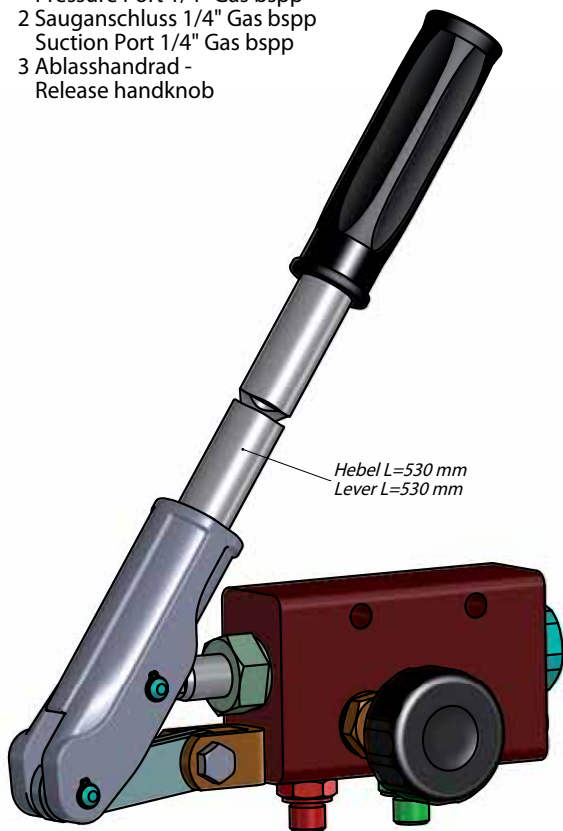
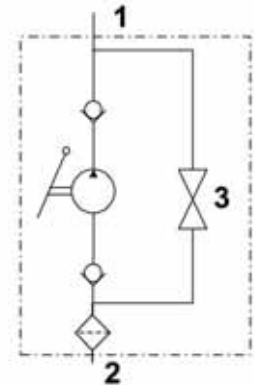

S [N] Diagramm Kraftaufwand am Hebel; L=530mm  
Diagram Pressure-Force; L=530mm

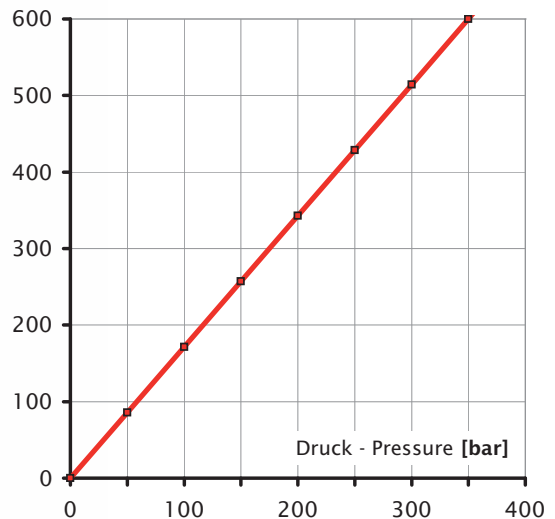

TYP TYPE	Fördervolumen Displacement [cm <sup>3</sup> ]	Druck Pressure [bar]
GL310R-20	17	350

*Unverbindliche Angaben. Änderungen vorbehalten. - Dimensions not binding. Modifications reserved without prior notice.  
Property of HANSA-TMP SRL. Copying without authorisation will be persecuted by Law.  
Eigentum von HANSA-TMP SRL. Nicht genehmigtes Kopieren wird strafrechtlich verfolgt.*

### Pumpe Typ GL325 - Pump Type GL325

Doppelhubfunktion für einfachwirkende Zylinder  
Double-stroke function for single acting cylinder

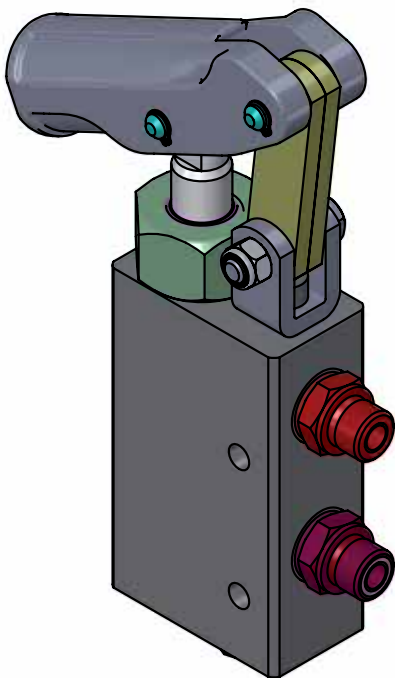
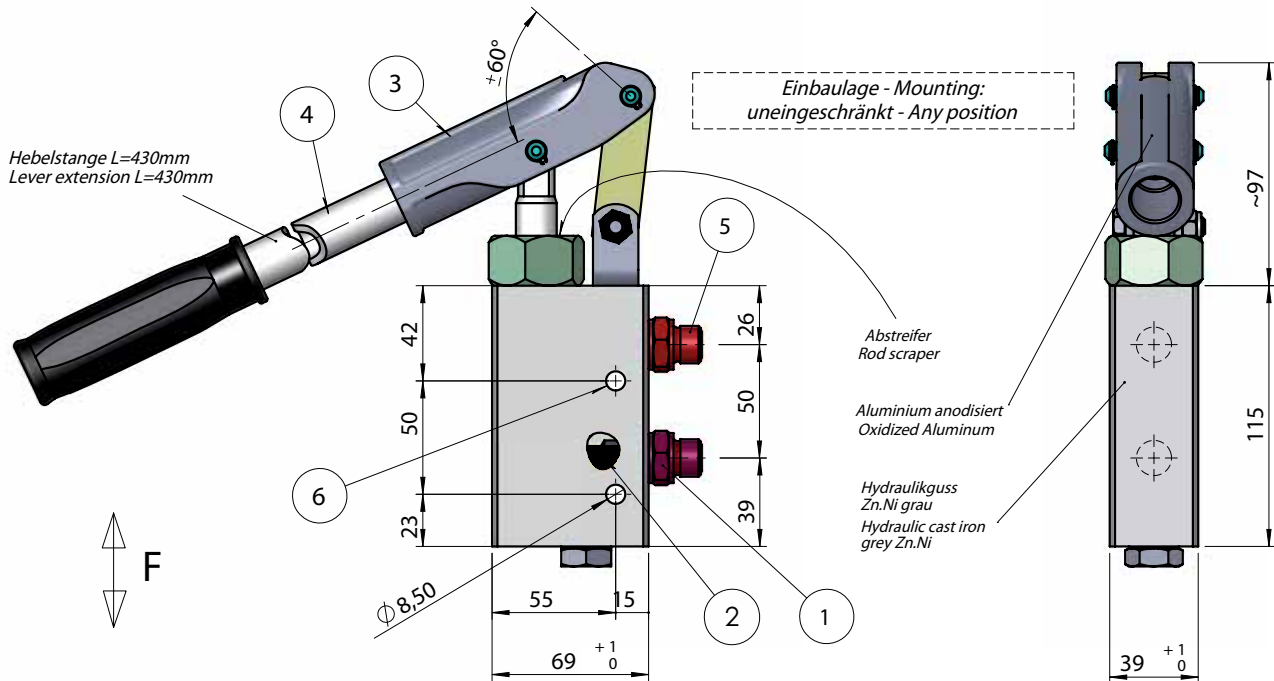

Gewicht - Weight ~3.8 [kg]

- 1 Sauganschluss ORFS11/16 (mit Filter)  
Suction Port ORFS11/16 (with filter)
- 2 Filter innen - Internal Filter
- 3 Hebelansatz -  
Action lever
- 4 Hebelstange -  
Action lever extension
- 5 Druckanschluss ORFS11/16 -  
Pressure Port ORFS11/16
- 6 Befestigungsbohrungen -  
Mounting holes



Diagramm Kraftaufwand am Hebel; L=430mm  
Diagram Pressure-Force; L=430m



TYP TYPE	Fördervolumen Displacement [cm <sup>3</sup> ]	Druck Pressure [bar]
GL325	23	300

Unverbindliche Angaben. Änderungen vorbehalten. - Dimensions not binding. Modifications reserved without prior notice.  
Property of HANSA-TMP SRL. Copying without authorisation will be persecuted by Law.  
Eigentum von HANSA-TMP SRL. Nicht genehmigtes Kopieren wird strafrechtlich verfolgt.

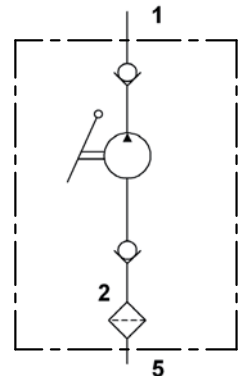
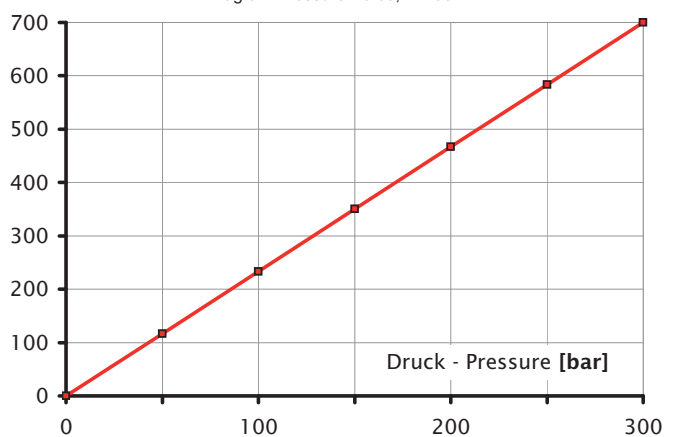
### Pumpe Typ GLA - Pump Type GLA

*Doppelhubfunktion für einfachwirkende Zylinder*  
*Double-stroke function for single acting cylinder*

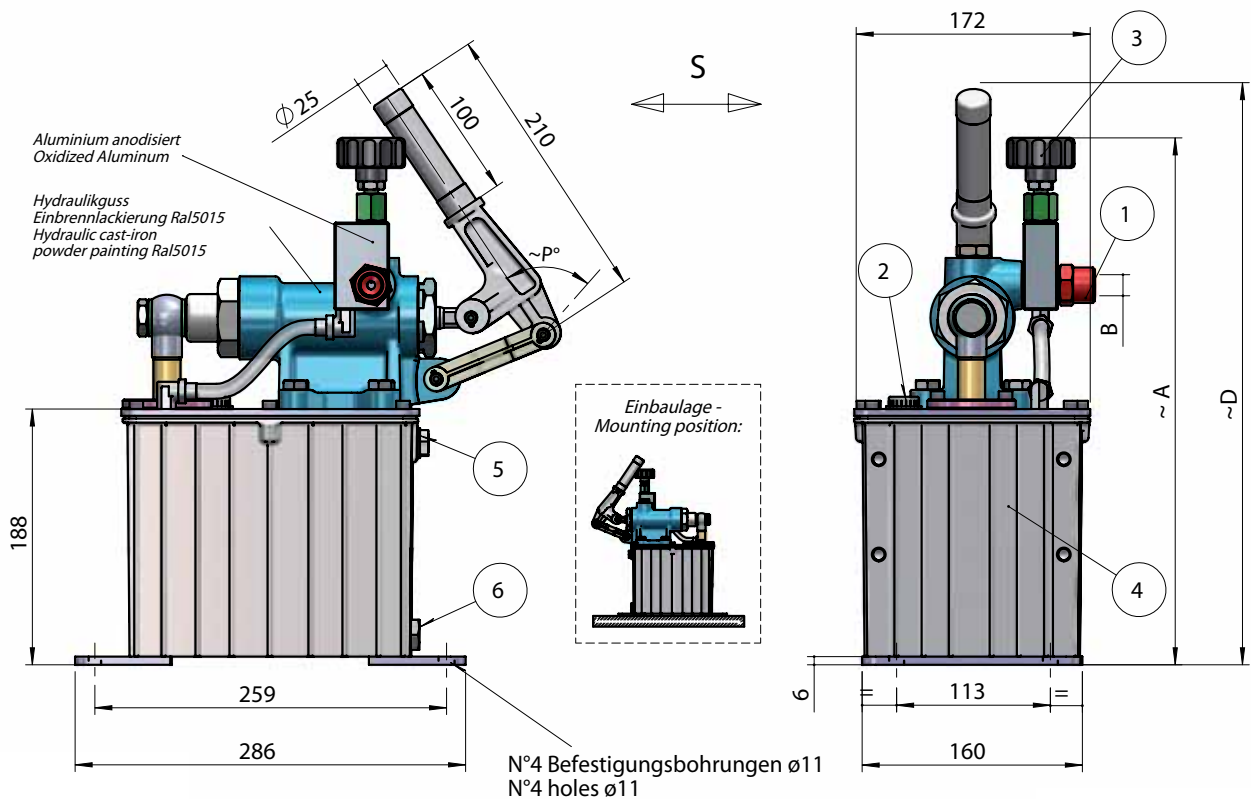

Gewicht - Weight ~11-12 [kg]

- 1 Druckanschluss - Pressure Port
- 2 Einfüll-Belüftungsstopfen - Filler plug with breather
- 3 Ablasshandrad - Release Handknob
- 4 Tank 4 l
- 5 Ölstandsanzeige - Oil Level indicator
- 6 Ablass-Stopfen 3/8" Gas bspp - Oil Discharge Plug 3/8" Gas bspp

TYP TYPE	Fördervolumen Displacement [cm <sup>3</sup> ]	Druck Pressure [bar]
GLA20	18	460
GLA25	29	320
GLA28	36	250
GLA30	42	220
GLA35	57	160
GLA40	87	120
GLA45	111	90

TYP - TYPE	A	B	D	P
GLA (20-25-28-30-35)	390	3/8" gas	420	75
GLA (40-45)	410	1/2" gas	430	90

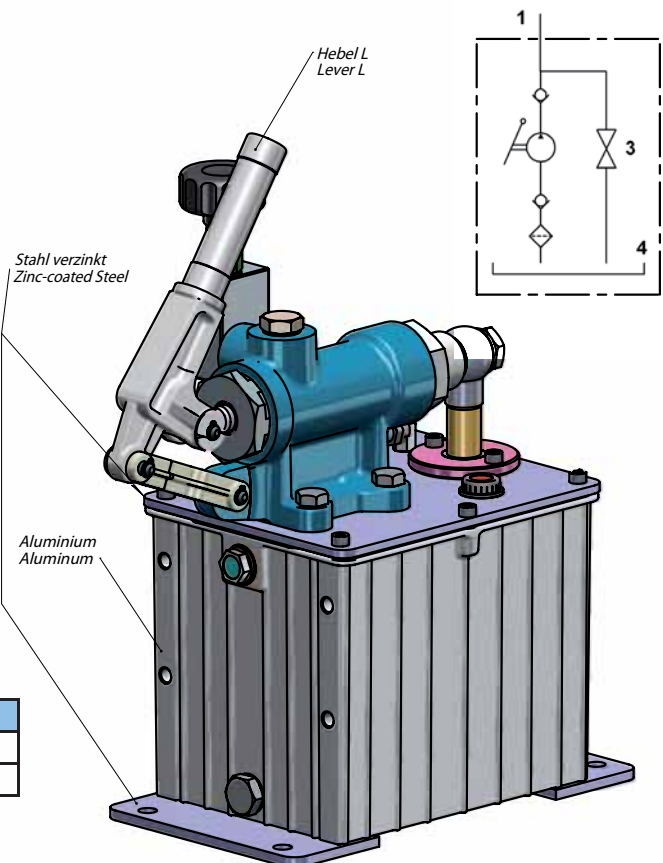

*Unverbindliche Angaben. Änderungen vorbehalten. - Dimensions not binding. Modifications reserved without prior notice.*  
*Property of HANSA-TMP SRL. Copying without authorisation will be persecuted by Law.*  
*Eigentum von HANSA-TMP SRL. Nicht genehmigtes Kopieren wird strafrechtlich verfolgt.*

### Pumpe Typ GLB - Pump Type GLB

*Doppelhubfunktion für einfachwirkende Zylinder*  
*Double-stroke function for single acting cylinder*

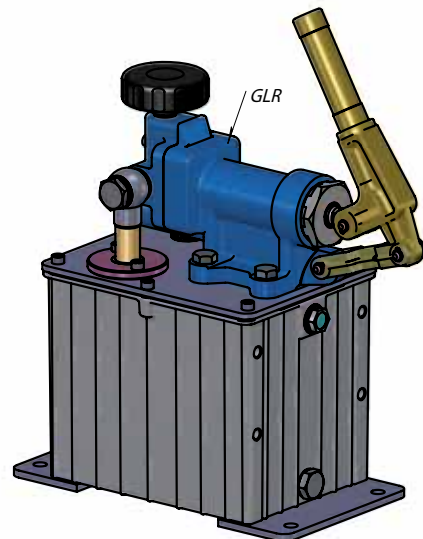
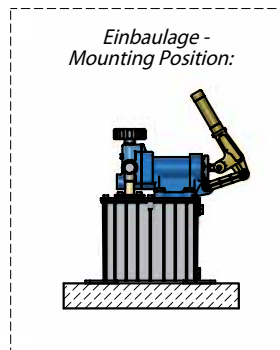
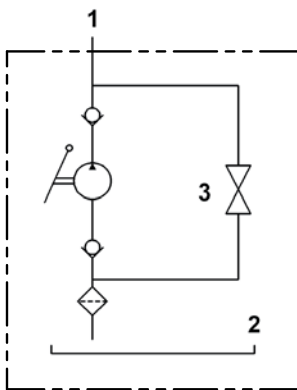
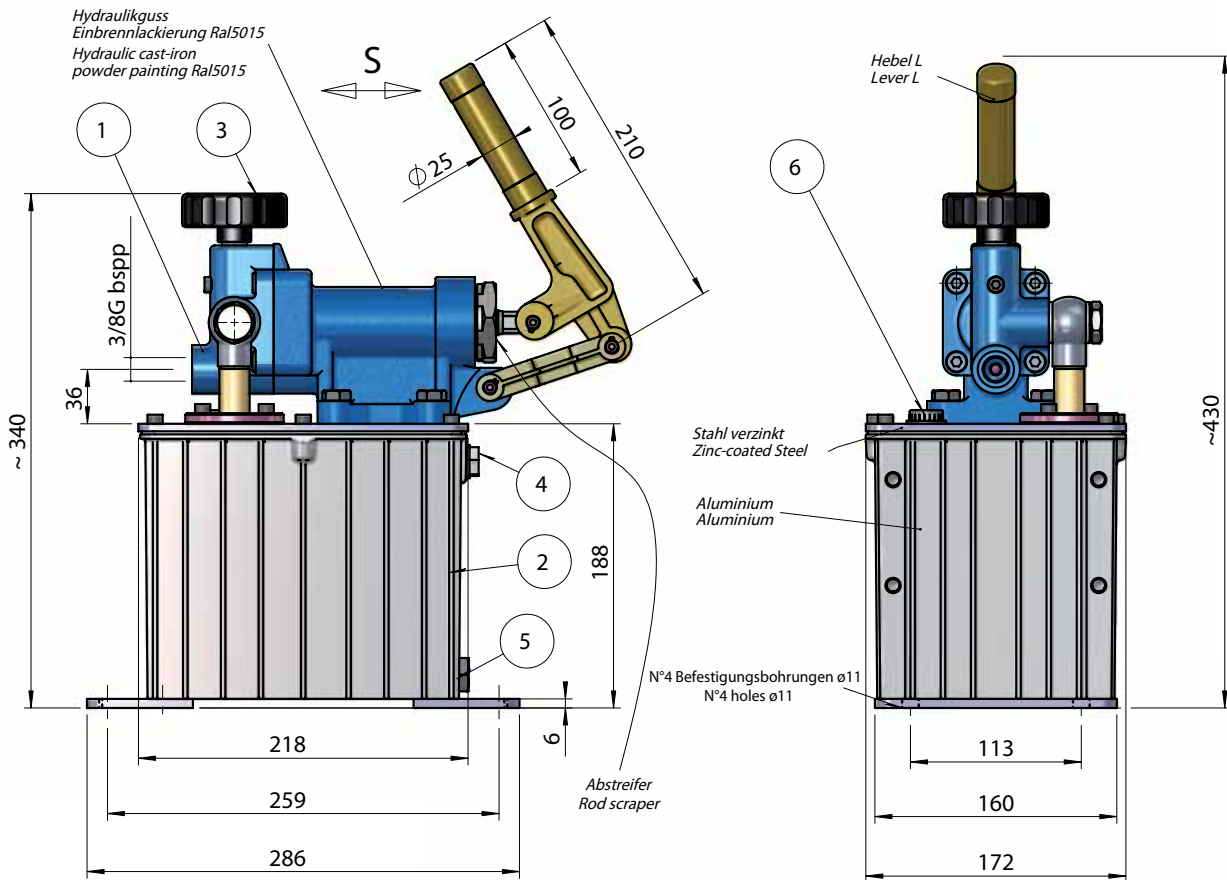

TYP TYPE	Fördervolumen Displacement [cm <sup>3</sup> ]	Druck Pressure [bar]
GLR20	18	460
GLR25	29	320
GLR28	36	250
GLR30	42	220

Gewicht - Weight ~11-12 [kg]

- 1 Druckanschluss - Pressure Port
- 2 Tank 4 l
- 3 Ablasshandrad - Release Handknob
- 4 Ölstandsanzeige - Oil Level Indicator
- 5 Ablass-Stopfen - Oil Discharge Plug
- 6 Einfüll-Belüftungsstopfen - Filler plug with breather

*Unverbindliche Angaben. Änderungen vorbehalten. - Dimensions not binding. Modifications reserved without prior notice.*  
*Property of HANSA-TMP SRL. Copying without authorisation will be persecuted by Law.*  
*Eigentum von HANSA-TMP SRL. Nicht genehmigtes Kopieren wird strafrechtlich verfolgt.*

### Pumpe Typ GL215-6 - Pump Type GL215-6

*Doppelhubfunktion für einfachwirkende Zylinder*  
*Double-stroke function for single acting cylinder*

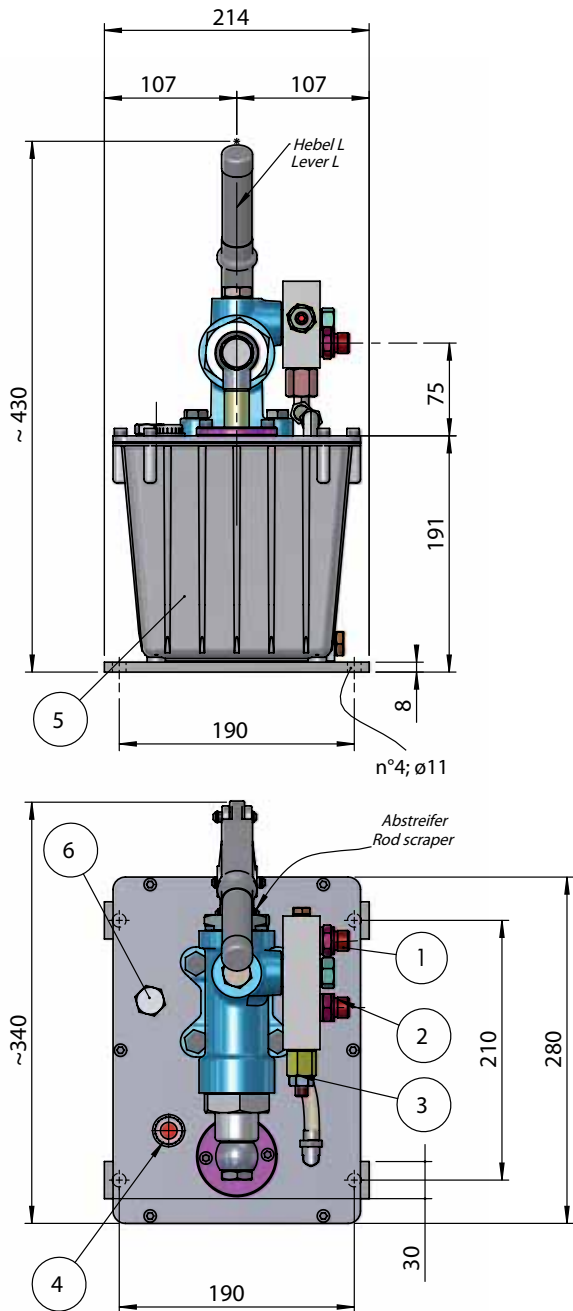

Gewicht - Weight ~11-12 [kg]

- 1 Druckanschluss 1 (3/8" gas bspp) - Pressure Port 1 (3/8" gas bspp)
- 2 Druckanschluss 2 (3/8" gas bspp) - Pressure Port 2 (3/8" gas bspp)
- 3 Max-Druckeinstellung - Relief valve Setting
- 4 Einfüll-Belüftungsstopfen - Filler Plug with breather
- 5 Aluminium Tank 6 l
- 6 Stopfen 3/8" gas bspp - Plug 3/8" gas bspp

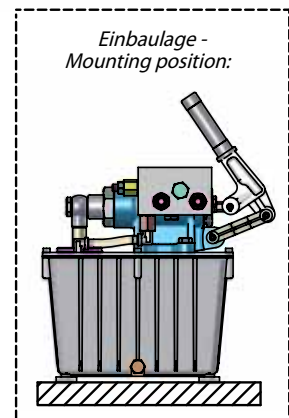
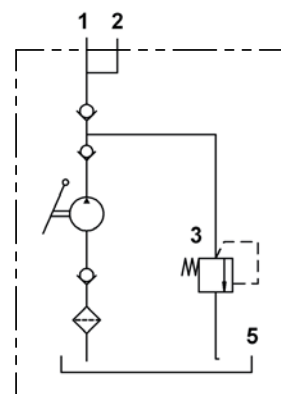
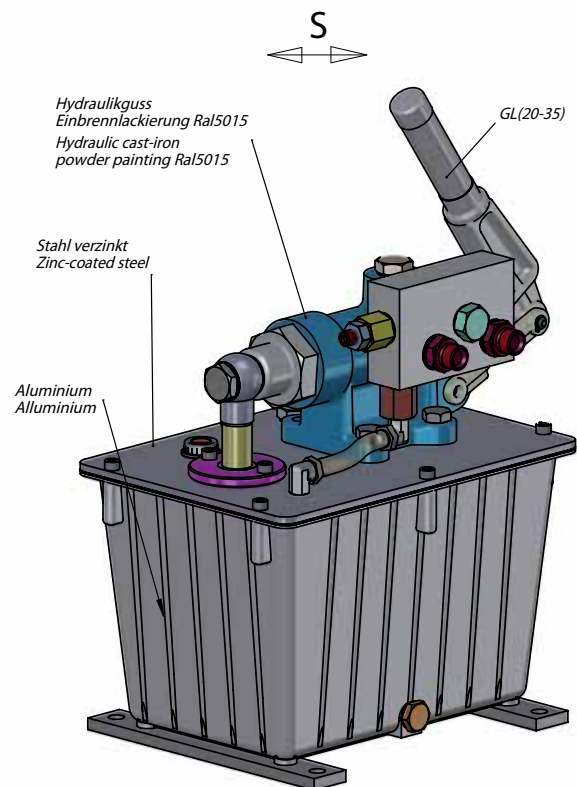

TYP TYPE	Fördervolumen Displacement [cm³]	Druck Pressure [bar]
GL215-6-20	18	460
GL215-6-25	29	320
GL215-6-28	36	250
GL215-6-30	42	220
GL215-6-35	57	160

*Unverbindliche Angaben. Änderungen vorbehalten. - Dimensions not binding. Modifications reserved without prior notice.*  
*Property of HANSA-TMP SRL. Copying without authorisation will be persecuted by Law.*  
*Eigentum von HANSA-TMP SRL. Nicht genehmigtes Kopieren wird strafrechtlich verfolgt.*

### Pumpe Typ GL215-10AL - Pump Type GL215-10AL

*Doppelhubfunktion für einfachwirkende Zylinder*  
*Double-stroke function for single acting cylinder*

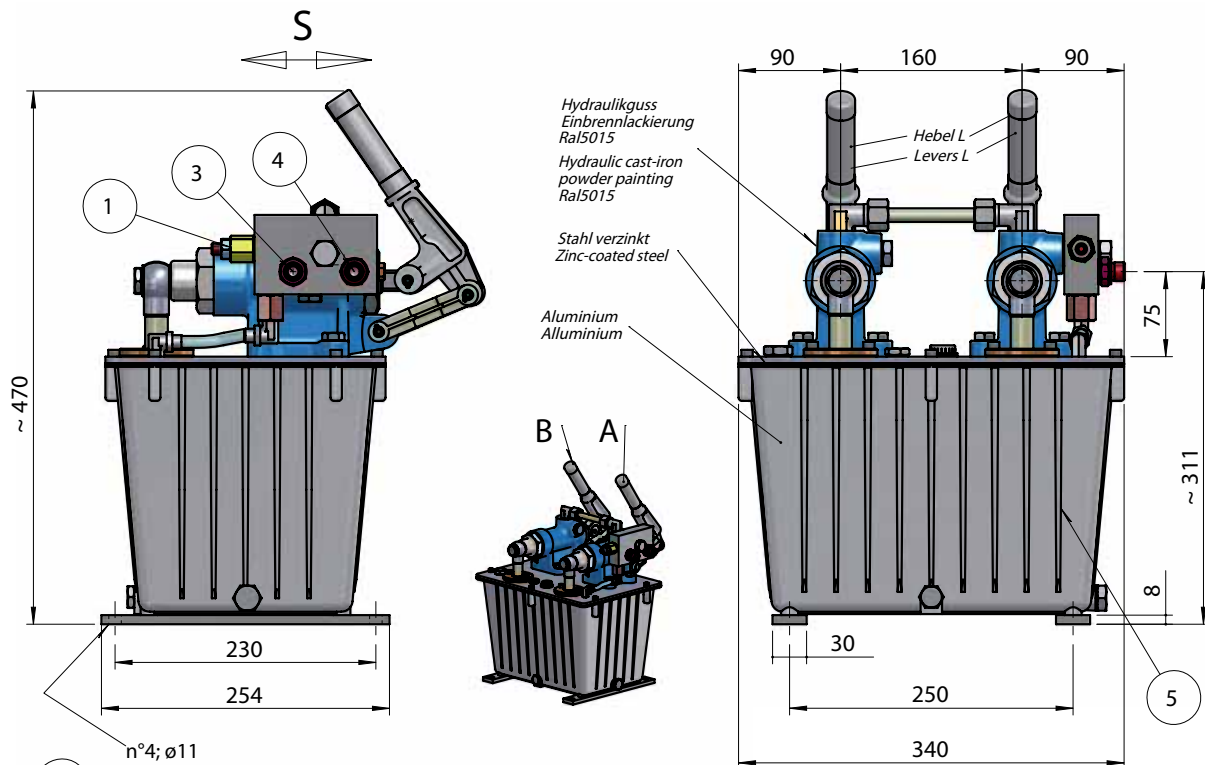

Gewicht - Weight ~18-20 [kg]

- 1 Druckbegrenzungsventil - Relief valve
- 2 Einfüll-Belüftungsstopfen - Filler Plug with breather
- 3 Druckanschluss 1 (3/8" gas bspp) - Pressure Port 1 (3/8" gas bspp)
- 4 Druckanschluss 2 (3/8" gas bspp) - Pressure Port 2 (3/8" gas bspp)
- 5 Aluminiumtank 10 l
- 6 Stopfen 3/8" Gas bspp - Plug 3/8" Gas bspp

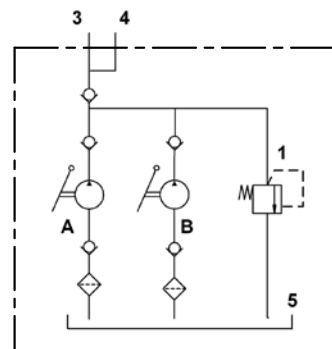
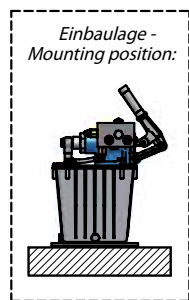
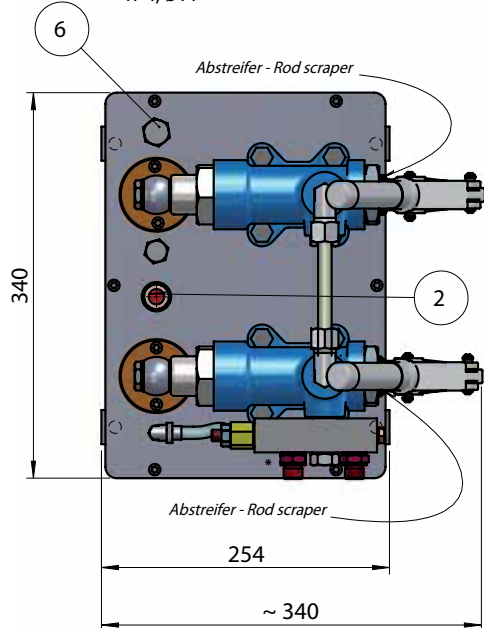

X, Y	Fördervolumen Displacement [cm³]	Druck Pressure [bar]
20	18	460
25	29	320
28	36	250
30	42	220
35	57	160

TYP TYPE	Fördervolumen Displacement [cm³]	Druck Pressure [bar]
GL215-10AL- X	A+A	P(A) / P(A)
GL215-10AL- X-Y	A+B	P(A) / P(B)
<i>Beispiel - Example:</i>		
GL215-10AL-20	18+18	460 / 460
GL215-10AL-25-35	29+57	320 / 160

*Unverbindliche Angaben. Änderungen vorbehalten. - Dimensions not binding. Modifications reserved without prior notice.*  
*Property of HANSA-TMP SRL. Copying without authorisation will be persecuted by Law.*  
*Eigentum von HANSA-TMP SRL. Nicht genehmigtes Kopieren wird strafrechtlich verfolgt.*

### Pumpe Typ GL2CN - Pump Type GL2CN

*Doppelhubfunktion für einfachwirkende Zylinder*  
*Double-stroke function for single acting cylinder*

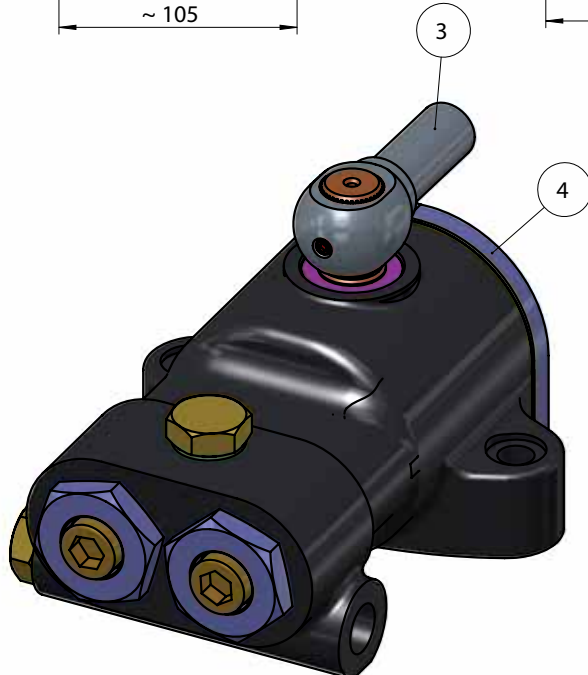
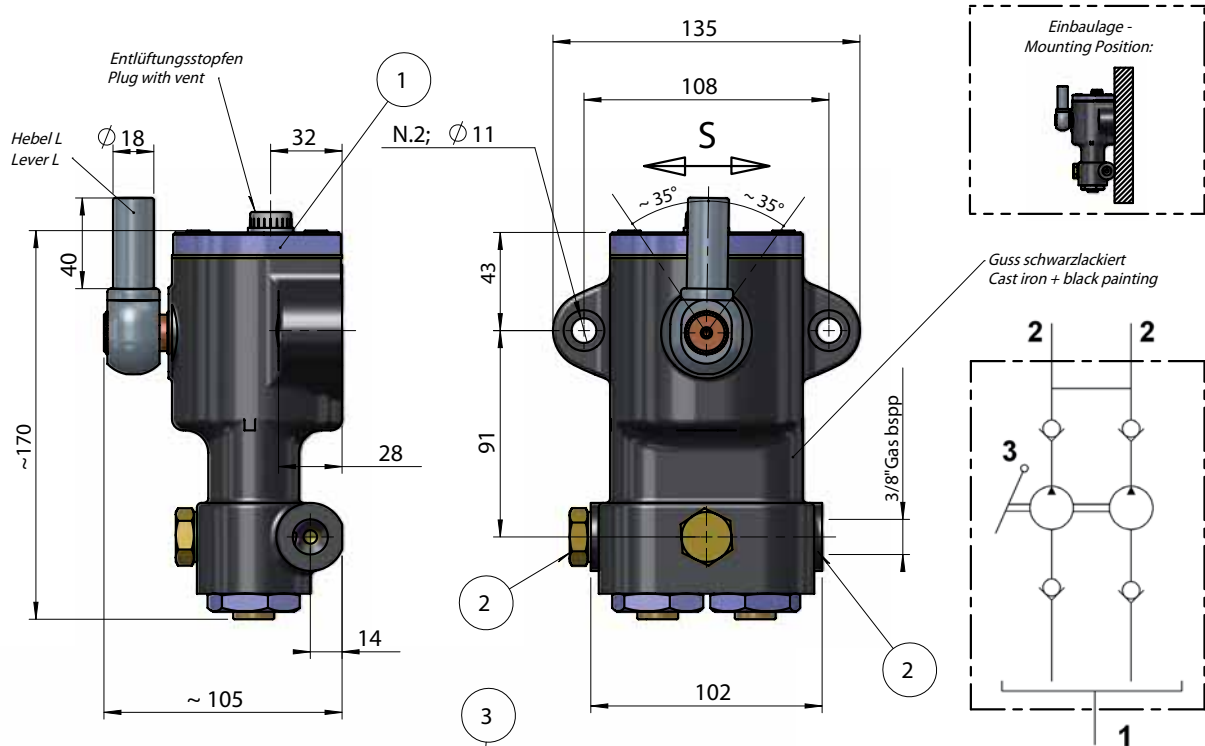

Gewicht Weight ~4,5 [kg]

- 1 Ölzulauf (3/8" gas bsp)  
Oil Inlet (3/8" gas bsp)
- 2 Druckanschluss - Pressure Port
- 3 Hebelansatz - Action Lever Pin
- 4 druckbeaufschlagbarer Deckel -  
Pressurizable Lid  
(on request, code GL2CxxN-OR)

TYP TYPE	Fördervolumen Displacement [cm <sup>3</sup> ]	Druck Pressure [bar]
GL2C12N	5,6	500
GL2C16N	10	250
GL2C21N	17,2	150

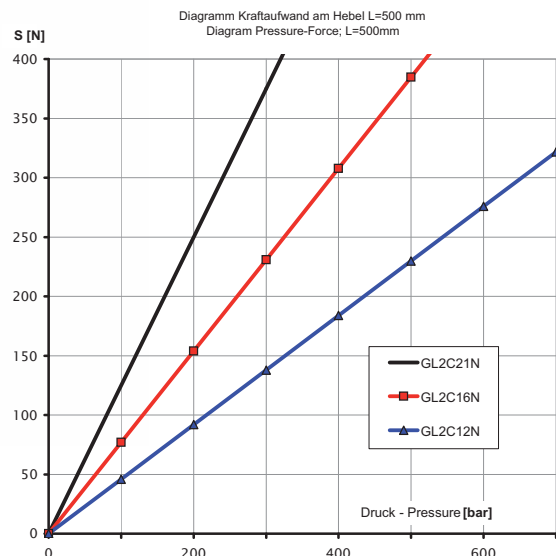

*Unverbindliche Angaben. Änderungen vorbehalten. - Dimensions not binding. Modifications reserved without prior notice.  
Property of HANSA-TMP SRL. Copying without authorisation will be persecuted by Law.  
Eigentum von HANSA-TMP SRL. Nicht genehmigtes Kopieren wird strafrechtlich verfolgt.*

### Pumpe Typ GL2CNR - Pump Type GL2CNR

*Doppelhubfunktion für einfachwirkende Zylinder*  
*Double-stroke function for single acting cylinder*

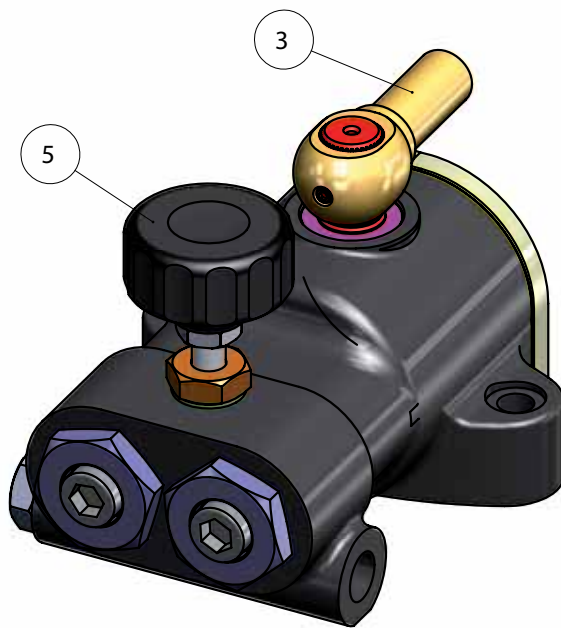
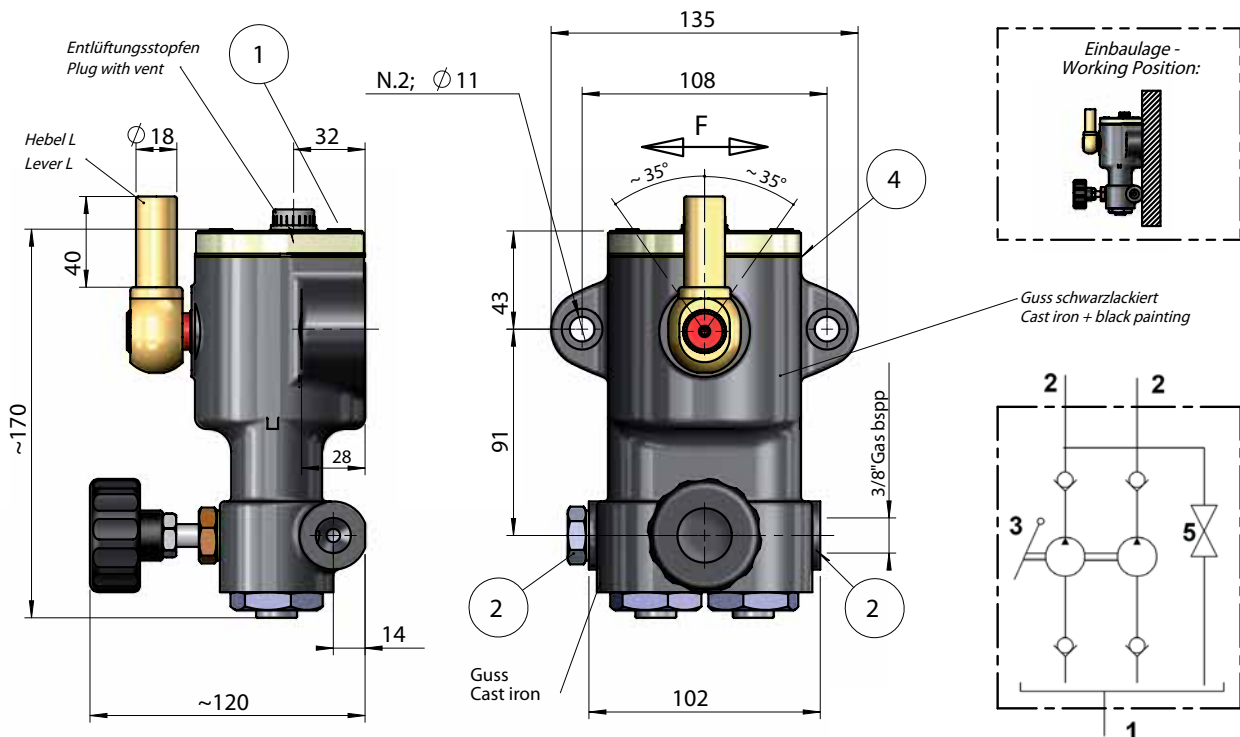

Gewicht - Weight ~4,5 [kg]

- 1 Ölzulauf 3/8" gas bspp - Oil Inlet 3/8" gas bspp
- 2 Druckanschluss - Pressure Port
- 3 Hebelansatz - Lever
- 4 druckbeaufschlagbarer Deckel - (auf Wunsch, Kode GL2CxxNR-OR) - Pressurizable Lid (on request, code GL2CxxNR-OR)
- 5 Ablasshandrad - Release handknob

TYP TYPE	Fördervolumen Displacement [cm³]	Druck Pressure [bar]
GL2C12NR	5,6	500
GL2C16NR	10	250
GL2C21NR	17,2	150

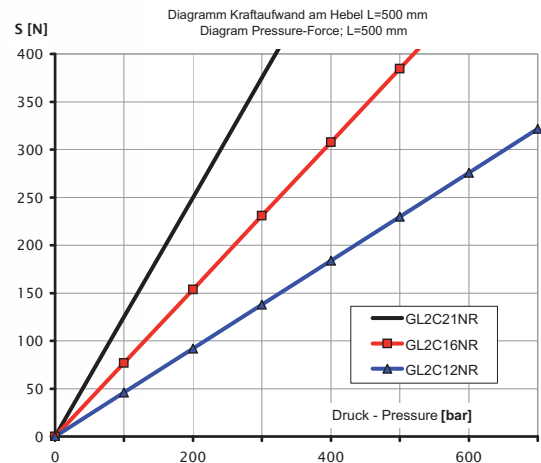

*Unverbindliche Angaben. Änderungen vorbehalten. - Dimensions not binding. Modifications reserved without prior notice.*  
*Property of HANSA-TMP SRL. Copying without authorisation will be persecuted by Law.*  
*Eigentum von HANSA-TMP SRL. Nicht genehmigtes Kopieren wird strafrechtlich verfolgt.*



### Pumpe Typ GLDE20H-ALL - Pump Type GLDE20H-ALL

*Doppelhubfunktion für einfachwirkende Zylinder*  
*Double-stroke function for single acting cylinder*

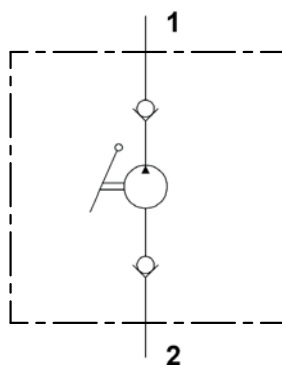
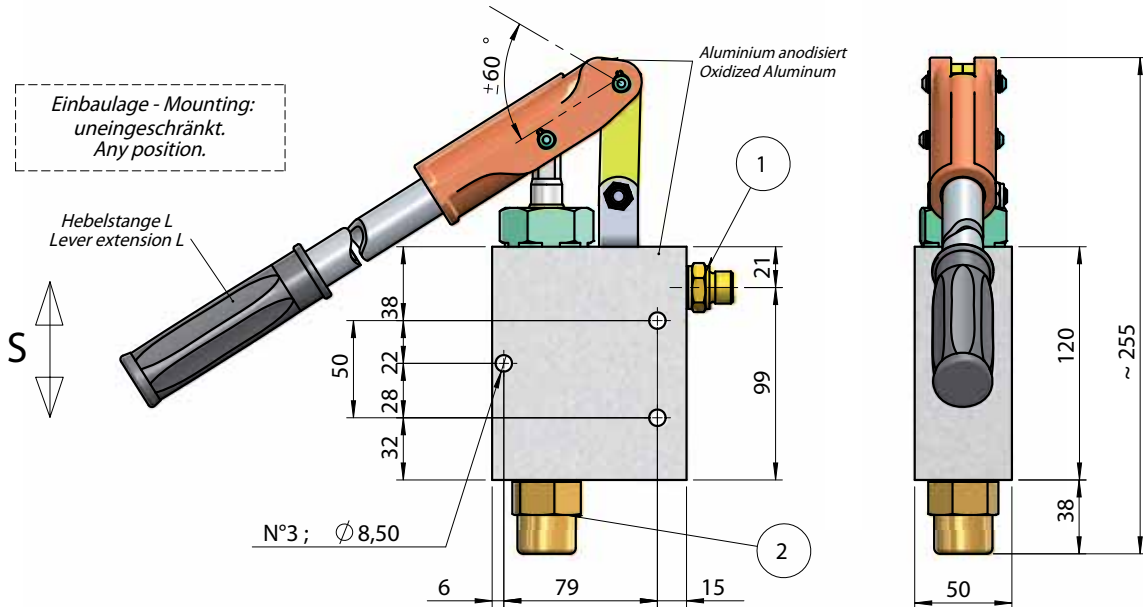

Gewicht - Weight ~3.2 [kg]

- 1 Druckanschluss 3/8" Gas bspp - Pressure Port 3/8" Gas bspp
- 2 Sauganschluss 1/2" Gas bspp - Suction Port 1/2" Gas bspp

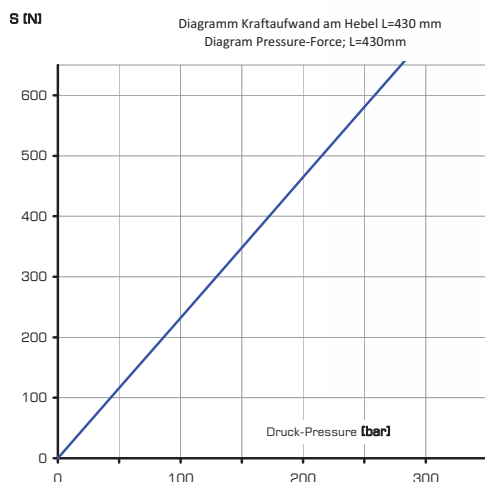
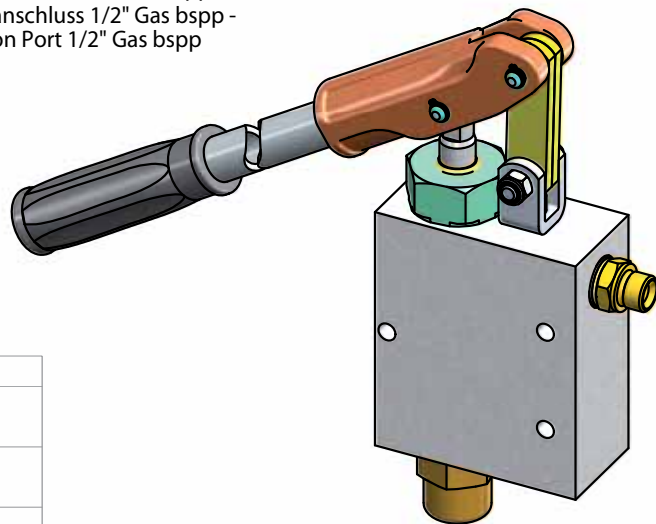

TYP TYPE	Fördervolumen Displacement [cm <sup>3</sup> ]	Druck Pressure [bar]
GLDE20H-ALL	15	280

*Unverbindliche Angaben. Änderungen vorbehalten. - Dimensions not binding. Modifications reserved without prior notice.*  
*Property of HANSA-TMP SRL. Copying without authorisation will be persecuted by Law.*  
*Eigentum von HANSA-TMP SRL. Nicht genehmigtes Kopieren wird strafrechtlich verfolgt.*

### Pumpe Typ GLDE25H-ALL- Pump Type GLDE25H-ALL

*Doppelhubfunktion für einfachwirkende Zylinder*  
*Double-stroke function for single acting cylinder*

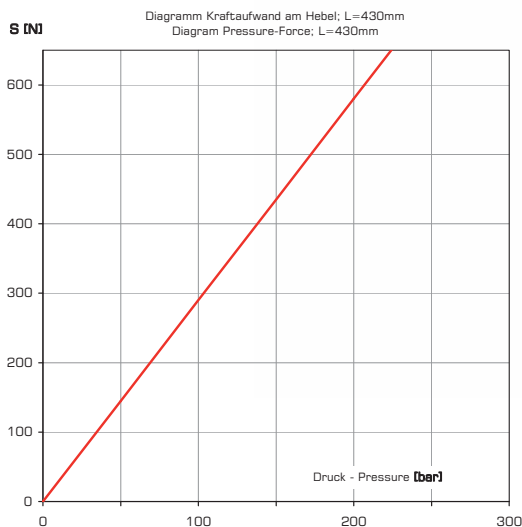
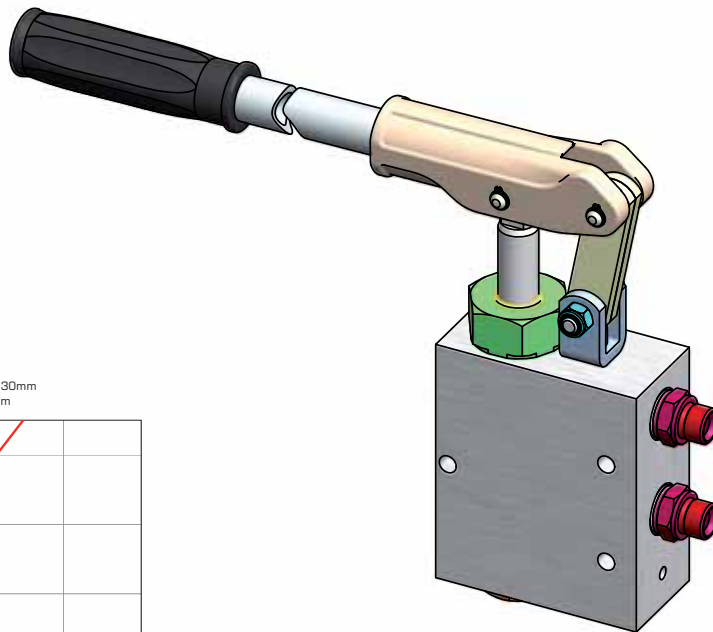
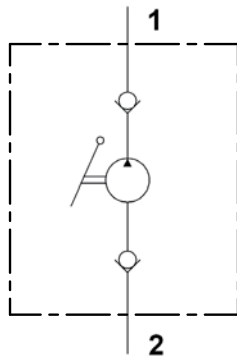
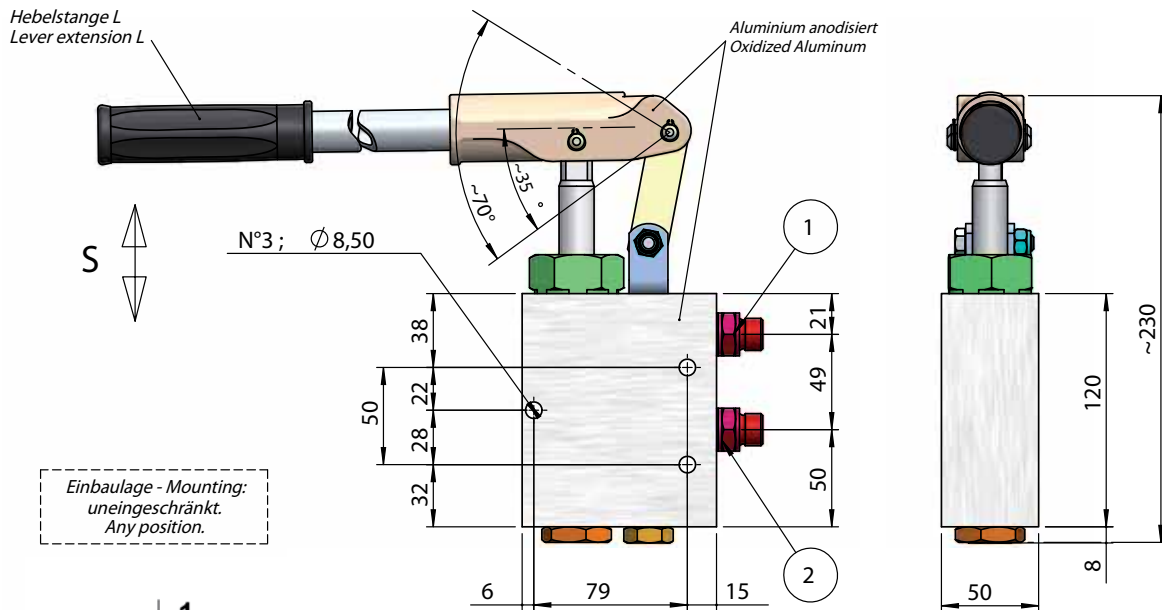

Gewicht - Weight ~3.2 [kg]

1 Druckanschluss 3/8" Gas bspp - Pressure Port 3/8" Gas bspp  
2 Sauganschluss 3/8" Gas bspp - Suction Port 3/8" Gas bspp

TYP TYPE	Fördervolumen Displacement [cm <sup>3</sup> ]	Druck Pressure [bar]
GLDE25H-ALL	25	150

*Unverbindliche Angaben. Änderungen vorbehalten. - Dimensions not binding. Modifications reserved without prior notice.  
Property of HANSA-TMP SRL. Copying without authorisation will be persecuted by Law.  
Eigentum von HANSA-TMP SRL. Nicht genehmigtes Kopieren wird strafrechtlich verfolgt.*

### Pumpe Typ GLNX - Pump Type GLNX

*Doppelhubfunktion für einfachwirkende Zylinder*  
*Double-stroke function for single acting cylinder*

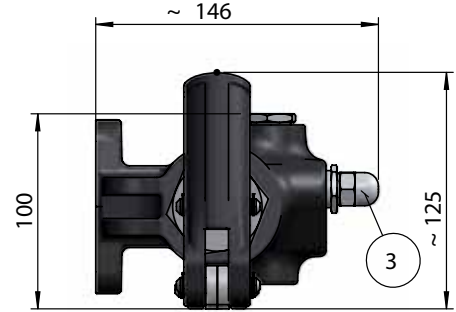
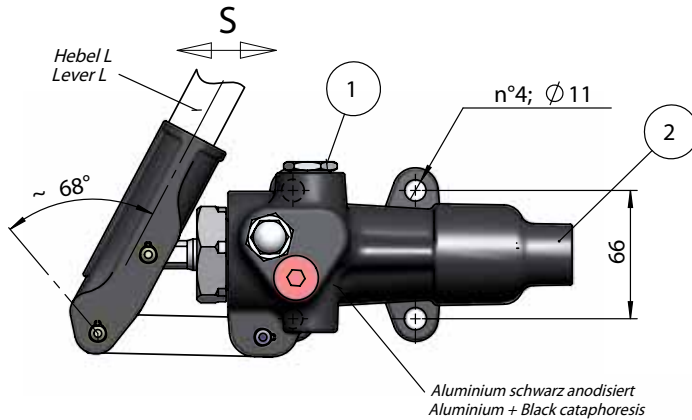

Aluminium schwarz anodisiert  
Aluminium + Black cataphoresis

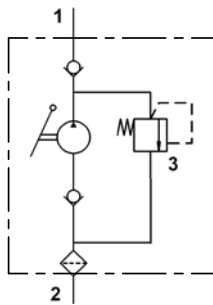
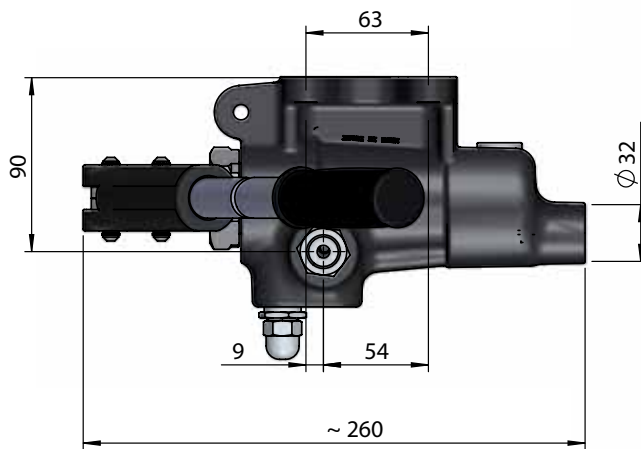

Einbaulage - Mounting:  
uneingeschränkt.  
Any position.

Gewicht - Weight [kg] ~ 3.1 - 3,4

- 1 Druckanschluss 3/8" Gas bspp - Pressure port 3/8" Gas bspp
- 2 Sauganschluss 1/2" Gas bspp - Suction port 1/2" Gas bspp
- 3 Druckbegrenzungsventil - Relief Valve

TYP TYPE	Fördervolumen Displacement [cm <sup>3</sup> ]	Druck Pressure [bar]
GLNX20	17	400
GLNX25	27	300
GLNX30	39	200
GLNX35	52	150

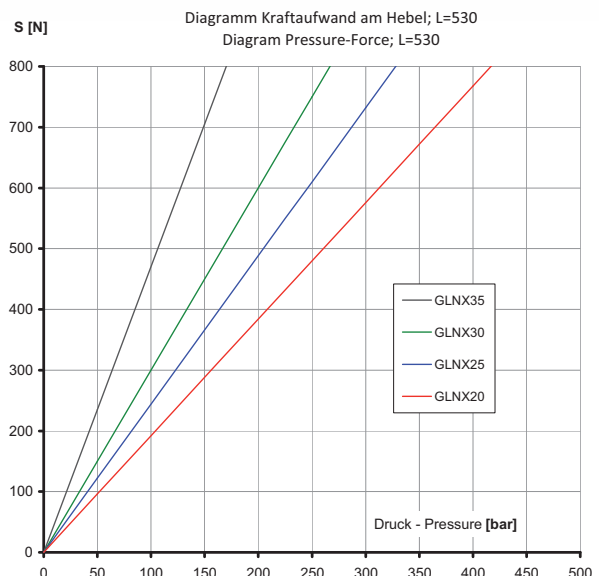

Unverbindliche Angaben. Änderungen vorbehalten. - Dimensions not binding. Modifications reserved without prior notice.  
Property of HANSA-TMP SRL. Copying without authorisation will be persecuted by Law.  
Eigentum von HANSA-TMP SRL. Nicht genehmigtes Kopieren wird strafrechtlich verfolgt.

### Pumpe Typ GLX - Pump Type GLX

*Doppelhubfunktion für einfachwirkende Zylinder*  
*Double-stroke function for single acting cylinder*

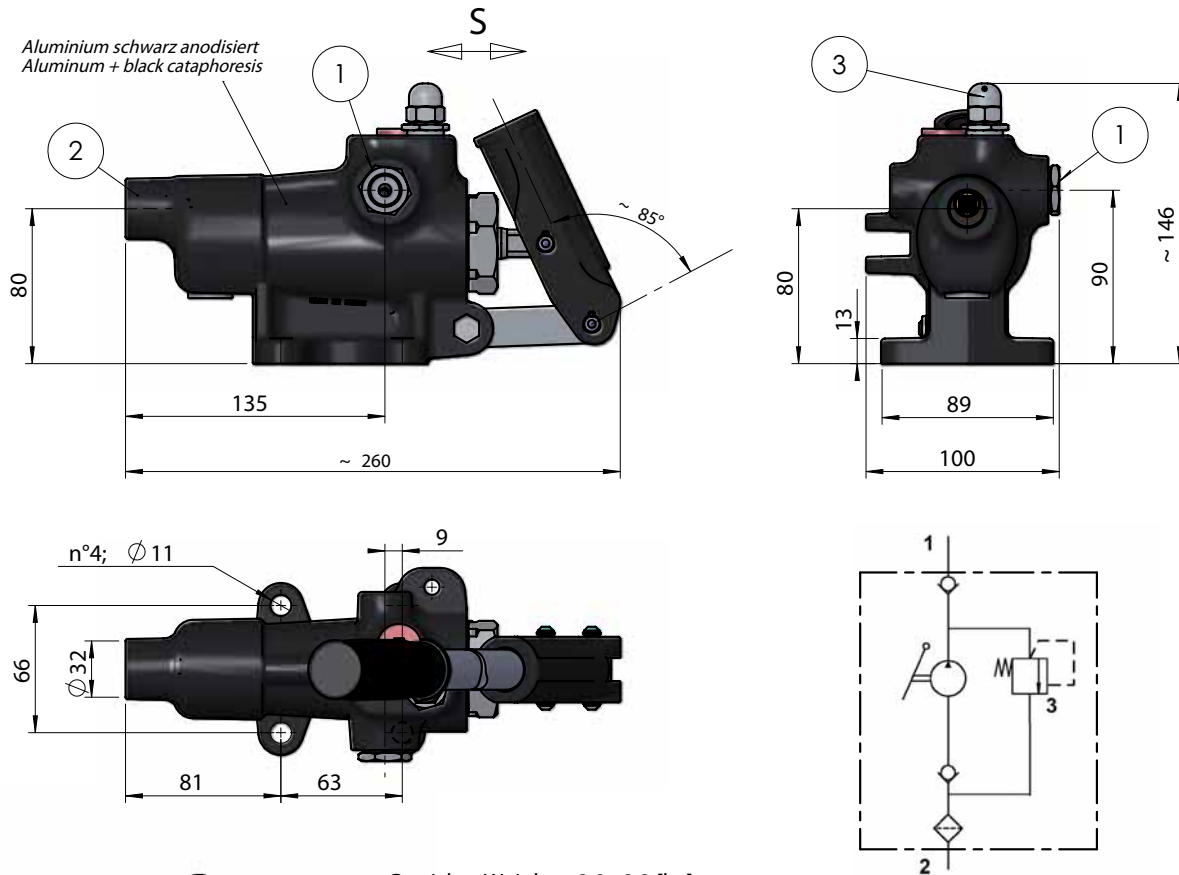

Gewicht - Weight ~ 3.0 - 3,3 [kg]

- 1 Druckanschluss 3/8" Gas Bsp - Pressure port 3/8" Gas Bsp
- 2 Sauganschluss 1/2" Gas Bsp - Suction port 1/2" Gas Bsp
- 3 Druckbegrenzungsventil - Relief Valve

*Einbaulage - Mounting: uneingeschränkt. Any position.*

TYP TYPE	Fördervolumen Displacement [cm <sup>3</sup> ]	Druck Pressure [bar]
GLX20	17	400
GLX25	27	300
GLX30	39	200
GLX35	52	150

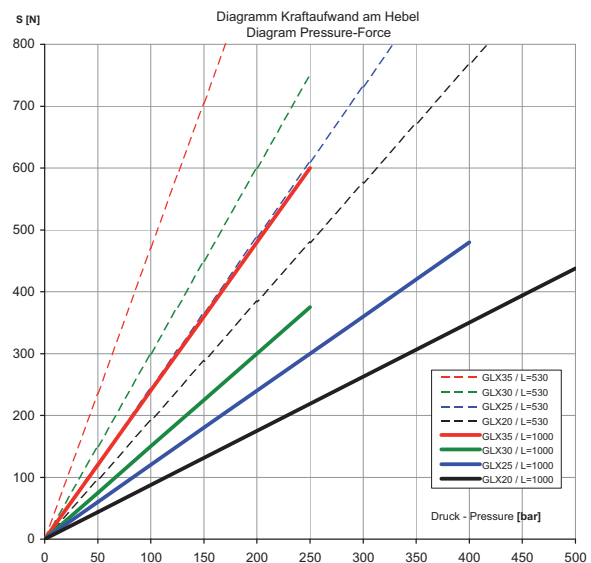

*Unverbindliche Angaben. Änderungen vorbehalten. - Dimensions not binding. Modifications reserved without prior notice.  
Property of HANSA-TMP SRL. Copying without authorisation will be persecuted by Law.  
Eigentum von HANSA-TMP SRL. Nicht genehmigtes Kopieren wird strafrechtlich verfolgt.*

### Pumpe Typ GL264 - Pump Type GL264

*Doppelhubfunktion für einfachwirkende Zylinder*  
*Double-stroke function for single acting cylinder*

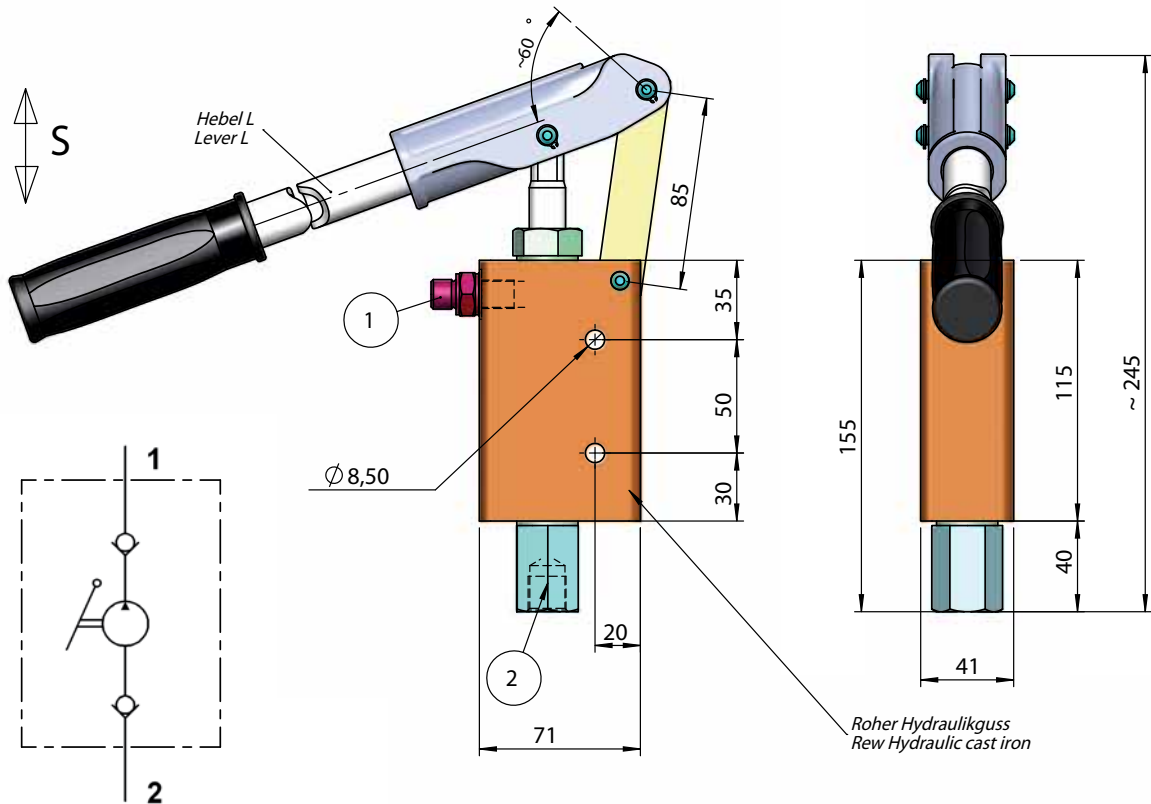

Gewicht - Weight ~4.3 [kg]

- 1 Druckanschluss 1/4" Gas bspp - Pressure Port 1/4" Gas bspp
- 2 Sauganschluss 3/8" Gas bspp Suction Port 3/8" Gas bspp

*Einbaulage - Mounting:*  
*uneingeschränkt - Any position*

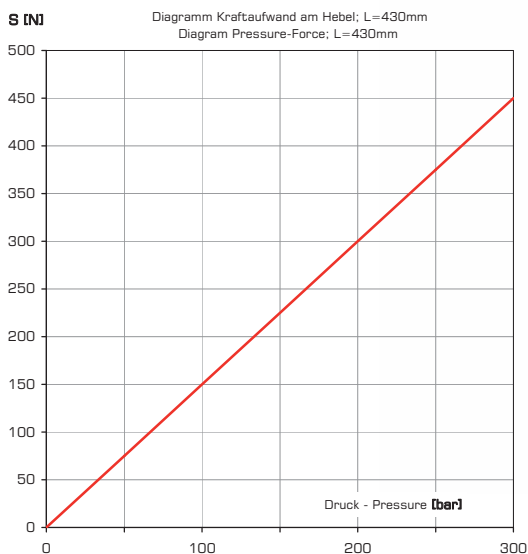
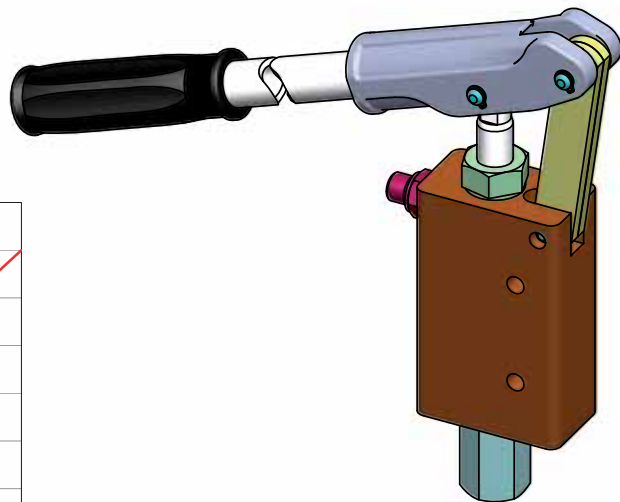

TYP TYPE	Fördervolumen Displacement [cm <sup>3</sup> ]	Druck Pressure [bar]
GL264	16	280

*Unverbindliche Angaben. Änderungen vorbehalten. - Dimensions not binding. Modifications reserved without prior notice.*  
*Property of HANSA-TMP SRL. Copying without authorisation will be persecuted by Law.*  
*Eigentum von HANSA-TMP SRL. Nicht genehmigtes Kopieren wird strafrechtlich verfolgt.*

### Pumpe Typ GL271R - Pump Type GL271R

*Doppelhubfunktion für einfachwirkende Zylinder*  
*Double-stroke function for single acting cylinder*

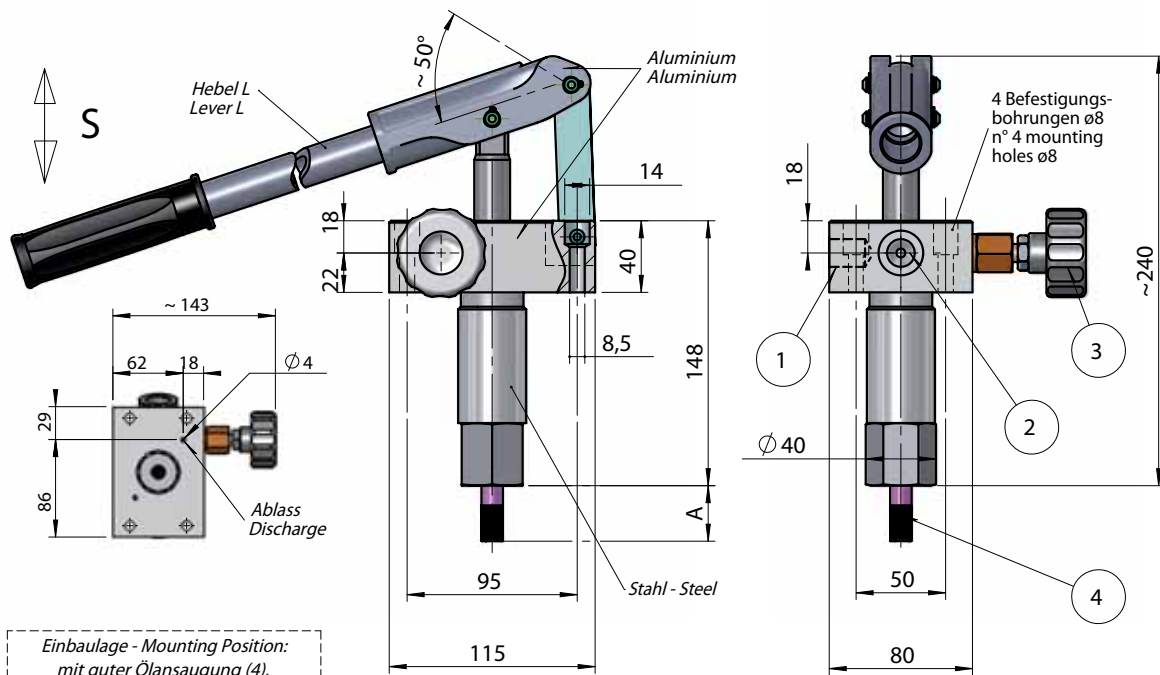

*Einbaulage - Mounting Position:  
mit guter Ölsaugung (4),  
uneingeschränkt.  
with good oil suction (4),  
Any position.*

Peso - Weight ~3.2[kg]

- 1 Druckanschluss 1 (3/8" gas bspp)  
Pressure port 1 (3/8" gas bspp)
- 2 Druckanschluss 2 (3/8" gas bspp)  
Pressure port 2 (3/8" gas bspp)
- 3 Ablassventil -  
Release handknob
- 4 Sauganschluss - Suction port

A Länge auf Anfrage  
A Length on request

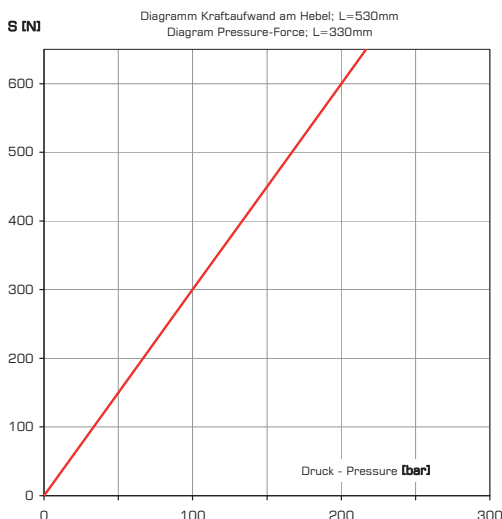
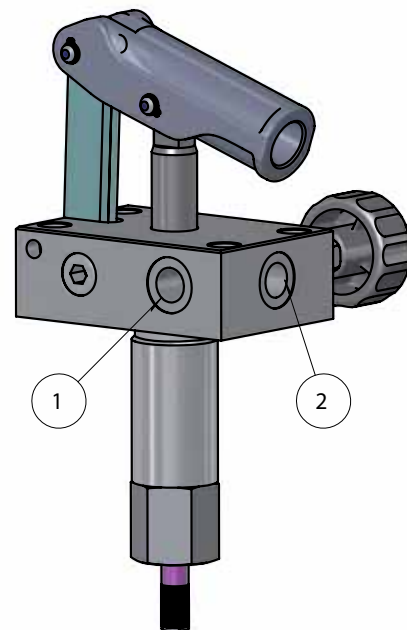
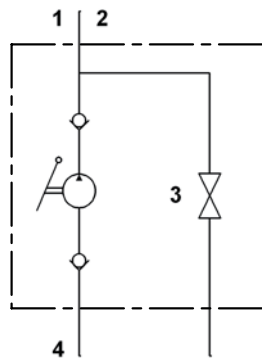

TYP TYPE	Fördervolumen Displacement [cm <sup>3</sup> ]	Druck Pressure [bar]
GL271R	25	150

*Unverbindliche Angaben. Änderungen vorbehalten. - Dimensions not binding. Modifications reserved without prior notice.  
Property of HANSA-TMP SRL. Copying without authorisation will be persecuted by Law.  
Eigentum von HANSA-TMP SRL. Nicht genehmigtes Kopieren wird strafrechtlich verfolgt.*

### Pumpe Typ GL277 - Pump Type GL277

*Doppelhubfunktion für einfachwirkende Zylinder*  
*Double-stroke function for single acting cylinder*

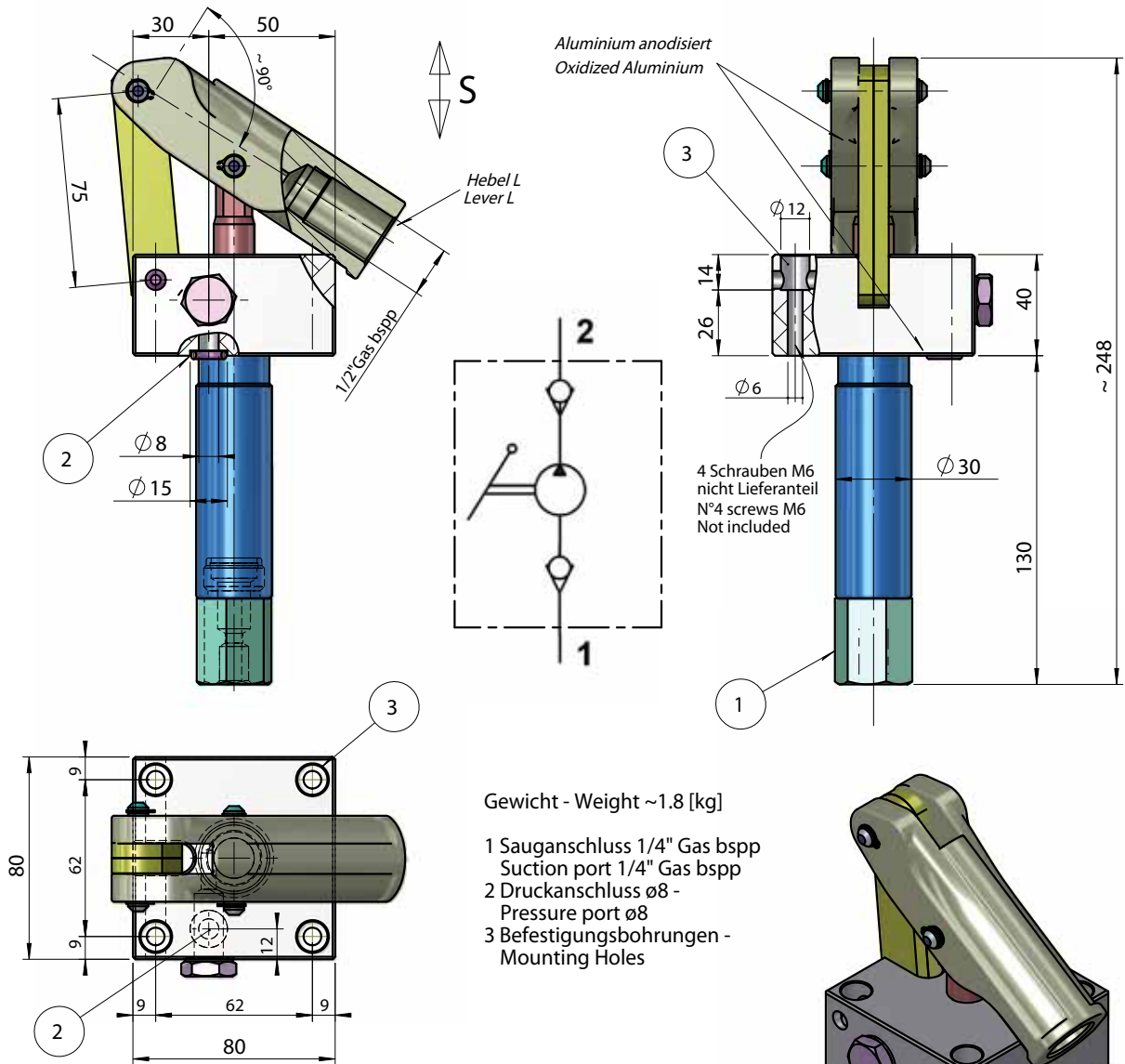

Gewicht - Weight ~1.8 [kg]

- 1 Sauganschluss 1/4" Gas bspp  
Suction port 1/4" Gas bspp
- 2 Druckanschluss ø8 -  
Pressure port ø8
- 3 Befestigungsbohrungen -  
Mounting Holes

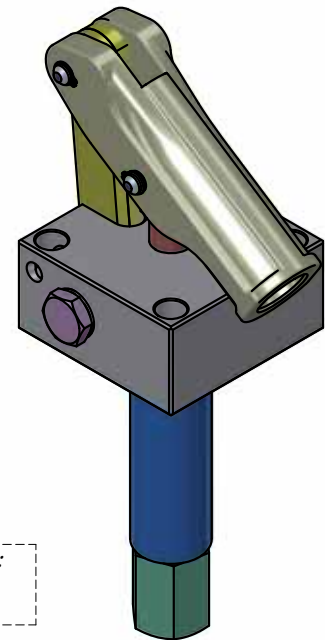

*Einbaulage - Mounting:  
uneingeschränkt  
Any position.*

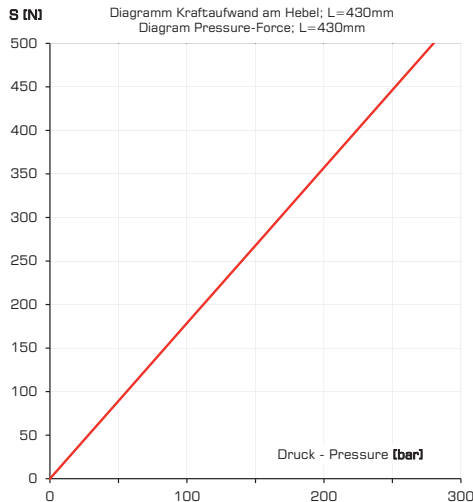

TYP TYPE	Fördervolumen Displacement [cm <sup>3</sup> ]	Druck Pressure [bar]
GL277	13	280

*Unverbindliche Angaben. Änderungen vorbehalten. - Dimensions not binding. Modifications reserved without prior notice.  
Property of HANSA-TMP SRL. Copying without authorisation will be persecuted by Law.  
Eigentum von HANSA-TMP SRL. Nicht genehmigtes Kopieren wird strafrechtlich verfolgt.*

### Pumpe Typ GL290-SS - Pump Type GL290-SS

*Doppelhubfunktion mit integriertem Umschaltventil für doppelwirkende Zylinder*  
*Double-Stroke function with flow diverter included for double-acting cylinders*

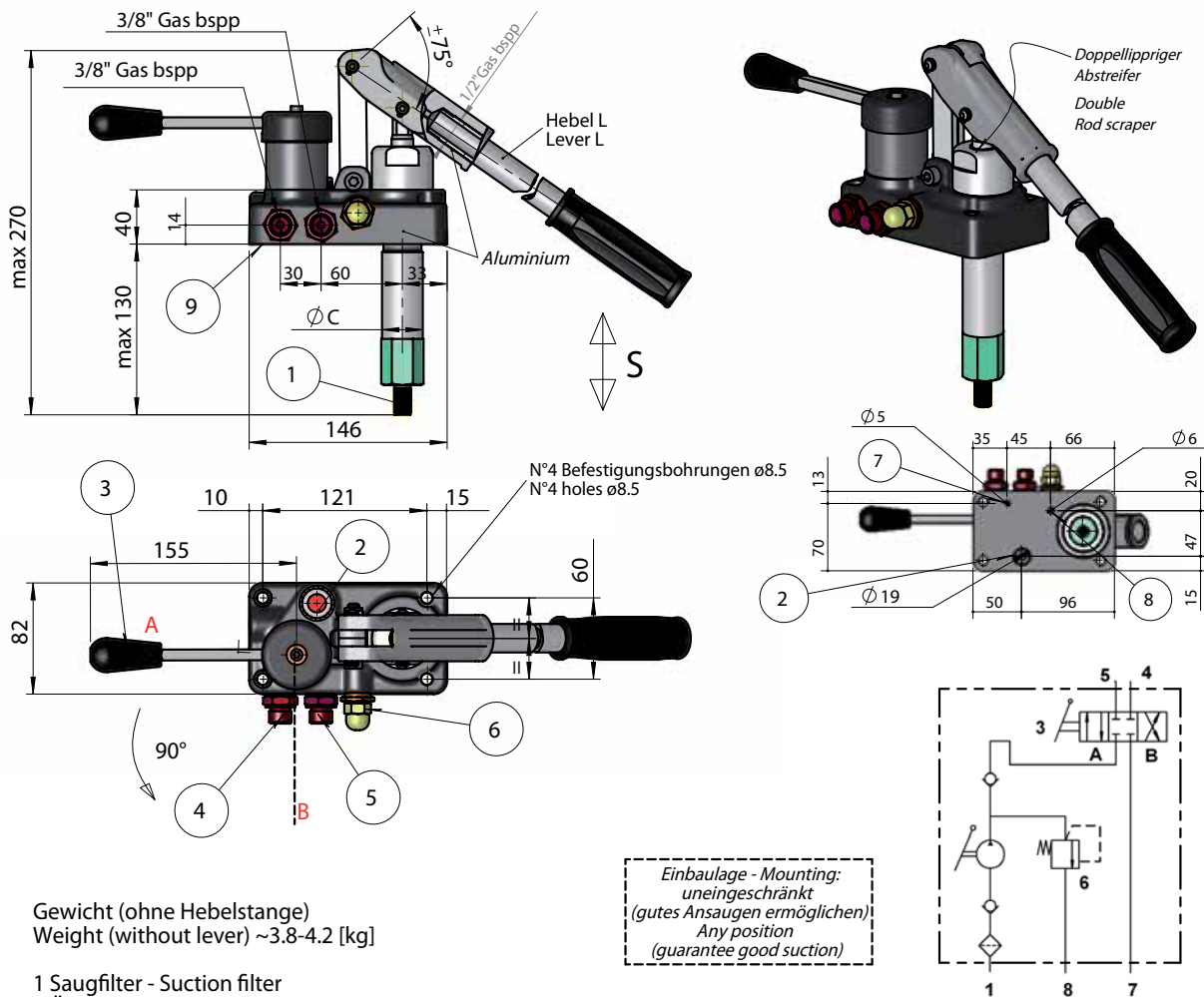

Gewicht (ohne Hebelstange)  
Weight (without lever) ~3.8-4.2 [kg]

- 1 Saugfilter - Suction filter
- 2 Öl-Einfüllstopfen - Filler Plug
- 3 Hebel Umschaltventil - Oil Flow Diverter Lever
- 4 Druckanschluss 1 - Pressure Port 1
- 5 Druckanschluss 2 - Pressure Port 2
- 6 Druckbegrenzungsventil - Relief Valve
- 7-8 Ablass - Discharge
- 9 Flachdichtung (auf Anfrage) - Flat seal (on request)

TYP TYPE	Fördervolumen Displacement [cm <sup>3</sup> ]	Druck Pressure [bar]
GL290-17-SS	11	380
GL290-20-SS	16	280
GL290-25-SS	25	180
GL290-28-SS	32	150
GL290-35-SS	40	100

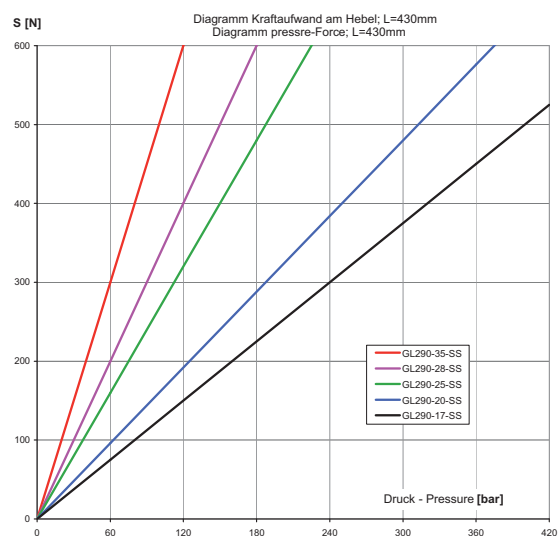

Typ - Type	GL290-17-SS	GL290-20-SS	GL290-25-SS	GL290-28-SS	GL290-35-SS
øC	25	30	35	38	45

*Unverbindliche Angaben. Änderungen vorbehalten. - Dimensions not binding. Modifications reserved without prior notice.*  
*Property of HANSA-TMP SRL. Copying without authorisation will be persecuted by Law.*  
*Eigentum von HANSA-TMP SRL. Nicht genehmigtes Kopieren wird strafrechtlich verfolgt.*



### Pumpe Typ GL292-SS - Pump Type GL292-SS

*Doppelhubfunktion für einfachwirkende Zylinder*  
*Double-Stroke function for single acting cylinders*

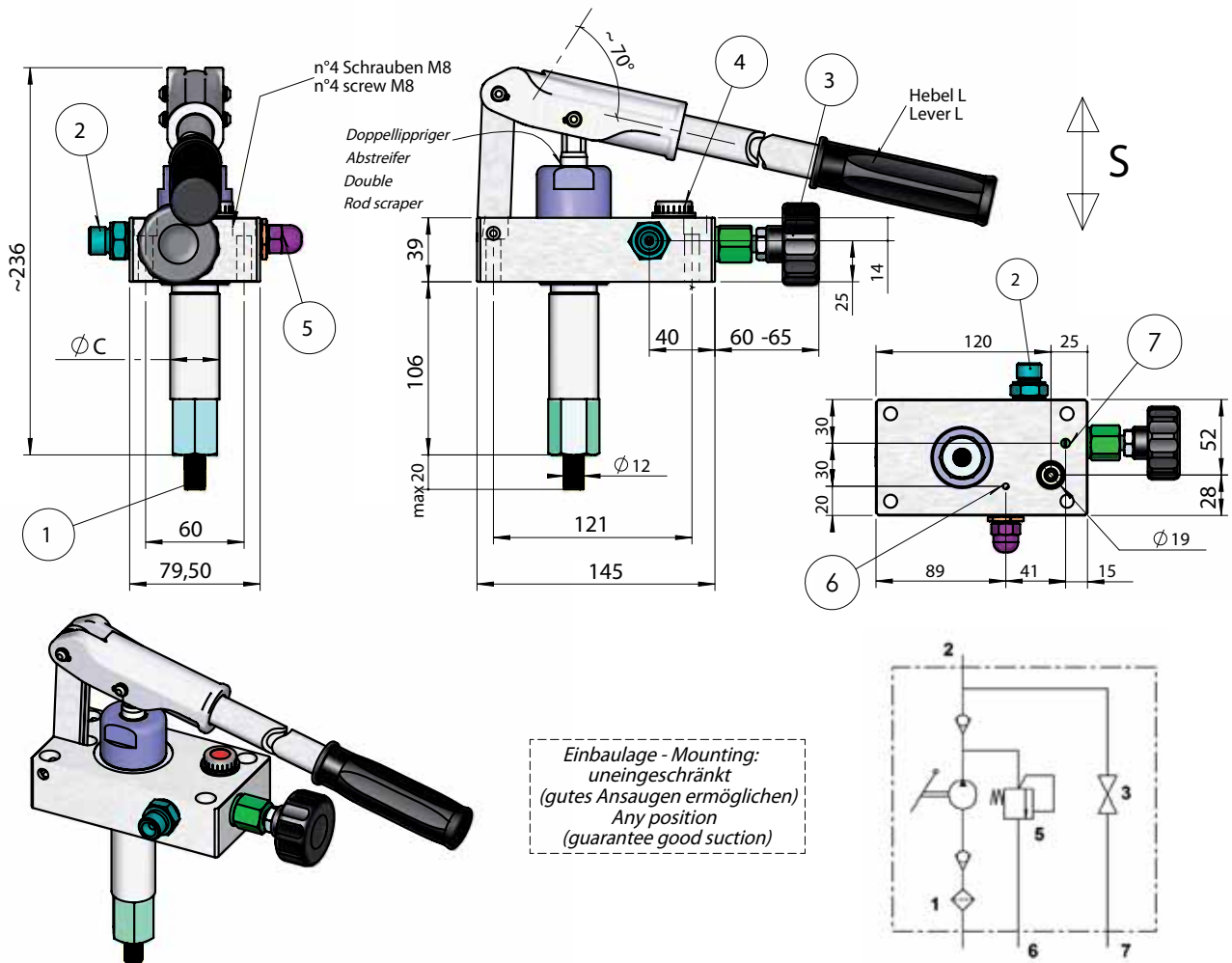

*Einbaulage - Mounting:  
uneingeschränkt  
(gutes Ansaugen ermöglichen)  
Any position  
(guarantee good suction)*

Gewicht (ohne Hebelstange)  
Weight (without lever) ~3,2-3,5 [kg]

- 1 Saugfilter - Suction Filter
- 2 Mandata 3/8" Gas bsp - Pressure Port 3/8" Gas bsp
- 3 Ablasshandrad - Release Handknob
- 4 Öl-Einfüllstopfen - Filler Plug
- 5 Einstellung Druckbegrenzungsventil - Relief Valve
- 6-7 Ablass - Discharge

TYP TYPE	Fördervolumen Displacement [cm <sup>3</sup> ]	Druck Pressure [bar]
GL292-17-SS	11	380
GL292-20-SS	16	280
GL292-25-SS	25	180
GL292-28-SS	32	150
GL292-35-SS	40	100

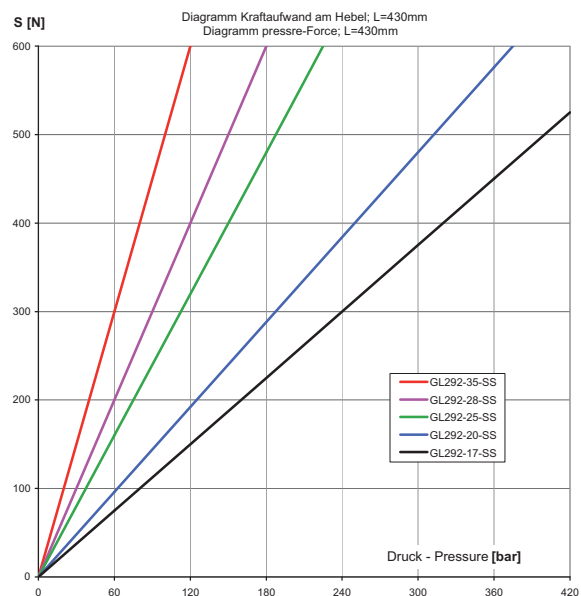

Typ - Type	GL290-17-SS	GL290-20-SS	GL290-25-SS	GL290-28-SS	GL290-35-SS
øC	25	30	35	38	45

*Unverbindliche Angaben. Änderungen vorbehalten. - Dimensions not binding. Modifications reserved without prior notice.  
Property of HANSA-TMP SRL. Copying without authorisation will be persecuted by Law.  
Eigentum von HANSA-TMP SRL. Nicht genehmigtes Kopieren wird strafrechtlich verfolgt.*

### Pumpe Typ GL303-ALL - Pump Type GL303-ALL

*Doppelhubfunktion für einfachwirkende Zylinder*  
*Double-stroke function for single acting cylinder*

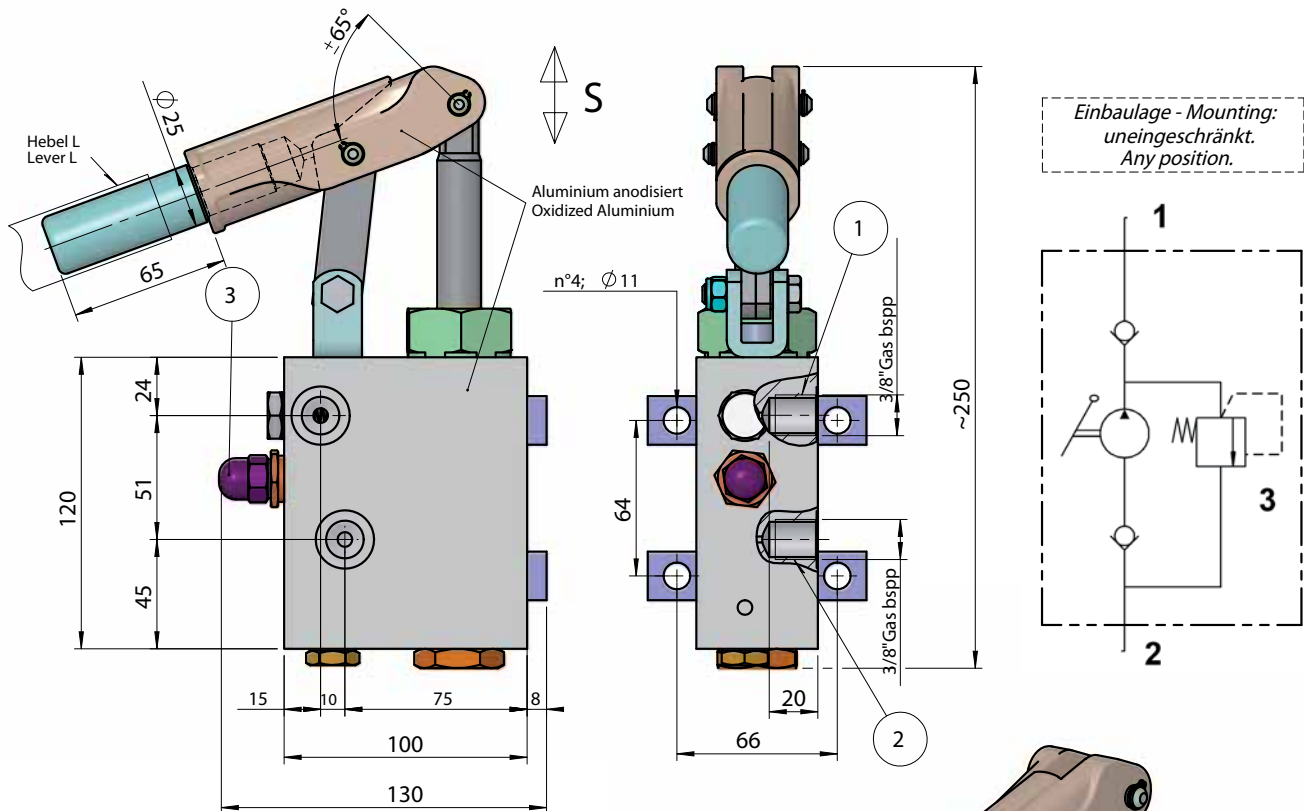

Gewicht - Weight ~3.2 [kg]

- 1 Druckanschluss 3/8" Gas bspp - Pressure Port 3/8" Gas bspp
- 2 Sauganschluss 3/8" Gas bspp - Suction Port 3/8" Gas bspp
- 3 Druckbegrenzungsventil - Relief Valve

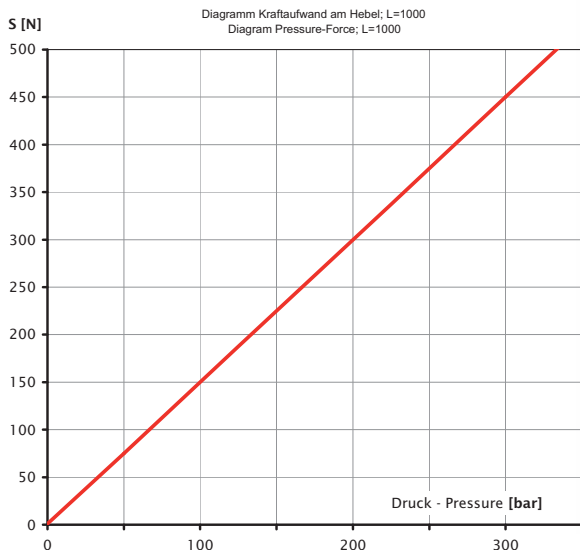
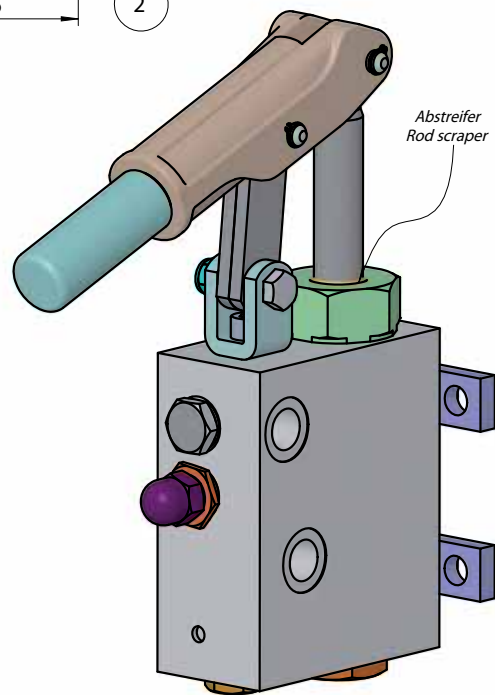

TYP TYPE	Fördervolumen Displacement [cm <sup>3</sup> ]	Druck Pressure [bar]
GL303-ALL	25	250

*Unverbindliche Angaben. Änderungen vorbehalten. - Dimensions not binding. Modifications reserved without prior notice.*  
*Property of HANSA-TMP SRL. Copying without authorisation will be persecuted by Law.*  
*Eigentum von HANSA-TMP SRL. Nicht genehmigtes Kopieren wird strafrechtlich verfolgt.*

### Pumpe Typ GL315-xxx - Pump Type GL315-xxx

*Doppelhubfunktion für einfachwirkende Zylinder*  
*Double-stroke function for single acting cylinder*

Gewicht - Weight ~2.7 [kg]

- 1 Druckanschluss 1/4" Gas bspp - Pressure Port 1/4" Gas bspp
- 2 Sauganschluss 1/4" Gas bspp - Suction Port 1/4" Gas bspp
- 3 Druckbegrenzungsventil - Relief valve
- 4 Ablasshandrad - Release handknob

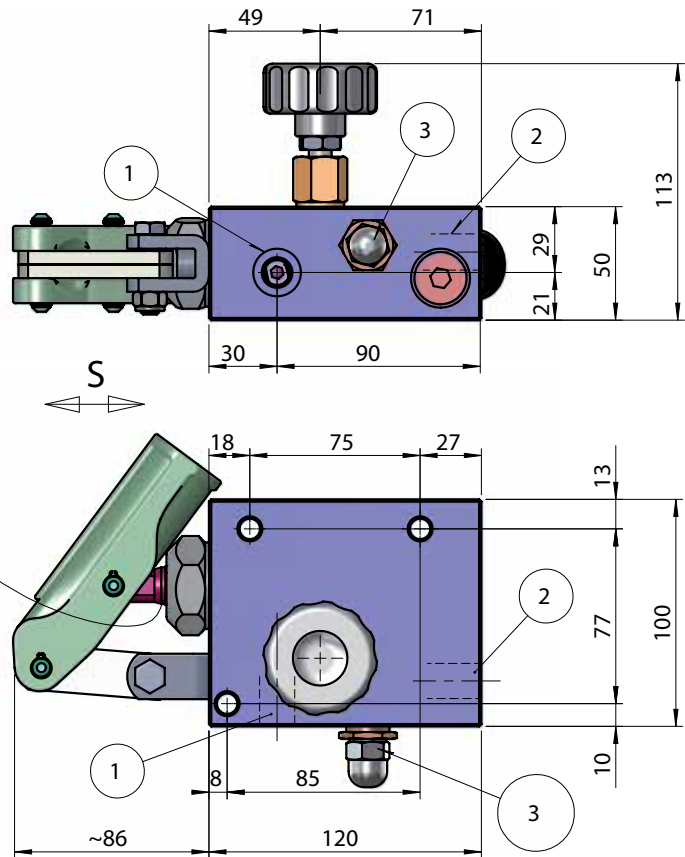
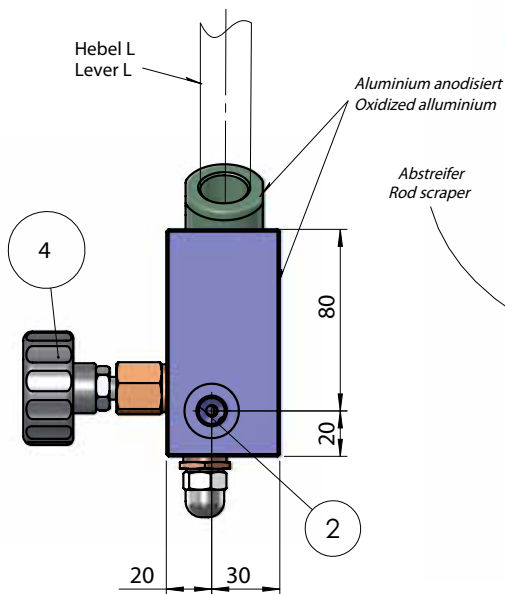

*Einbaulage - Mounting: uneingeschränkt Any position*

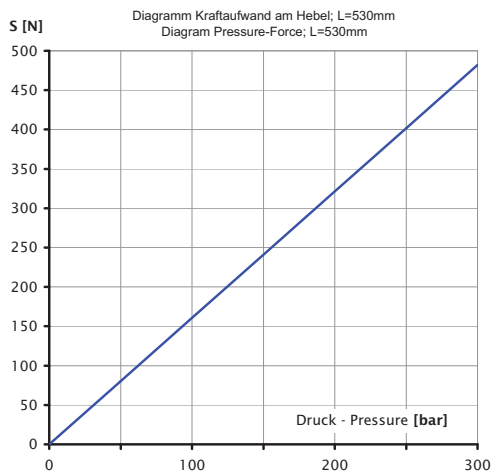

Code:	GL315	GL315-VM	GL315-VMR
Hydraulikschema Hydraulic scheme			
Pumpe Pump			

TYP TYPE	Fördervolumen Displacement [cm³]	Druck Pressure [bar]
GL315-xxx	17	280

*Unverbindliche Angaben. Änderungen vorbehalten. - Dimensions not binding. Modifications reserved without prior notice.*  
*Property of HANSA-TMP SRL. Copying without authorisation will be persecuted by Law.*  
*Eigentum von HANSA-TMP SRL. Nicht genehmigtes Kopieren wird strafrechtlich verfolgt.*

### Pumpe Typ GL12NG - Pump Type GL12NG

*Doppelhubfunktion für einfachwirkende Zylinder*  
*Double-stroke function for single acting cylinder*

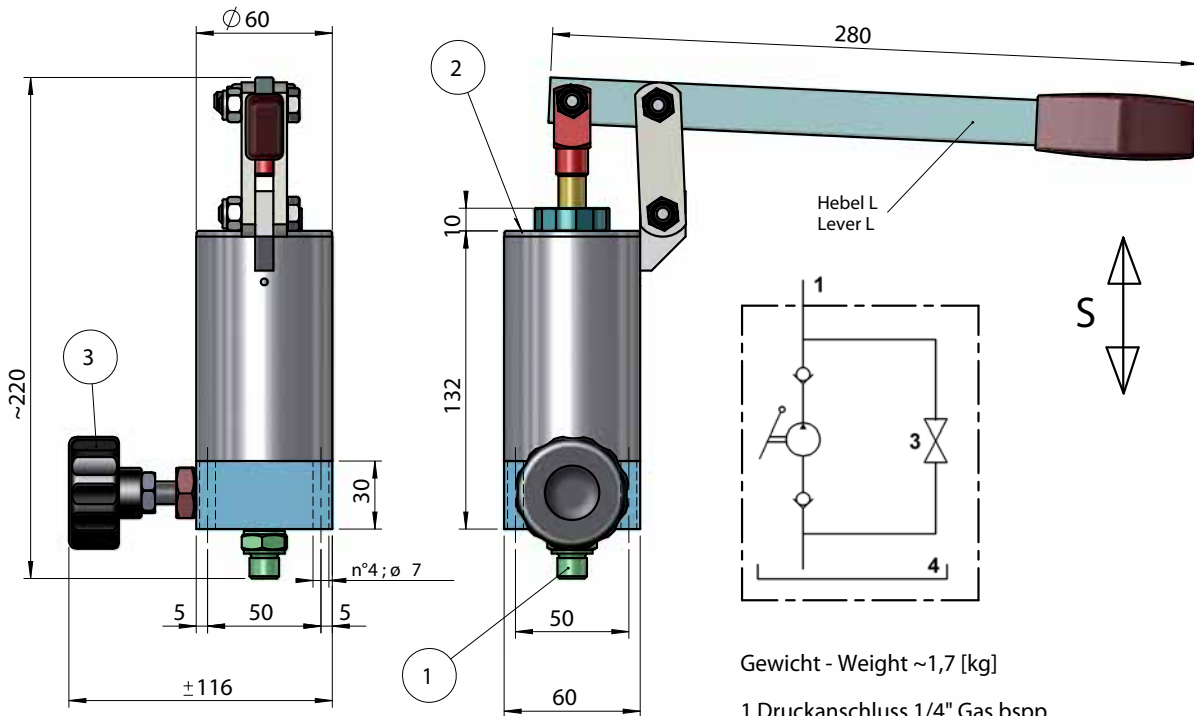

Gewicht - Weight ~1,7 [kg]

- 1 Druckanschluss 1/4" Gas bspw  
Pressure Port 1/4" Gas bspw
- 2 Öl-Einfüllstopfen - Filler Plug
- 3 Ablasshandrad - Release Handknob
- 4 Tank 0,07 l

Einbaulage - Mounting:  
uneingeschränkt - Any positions

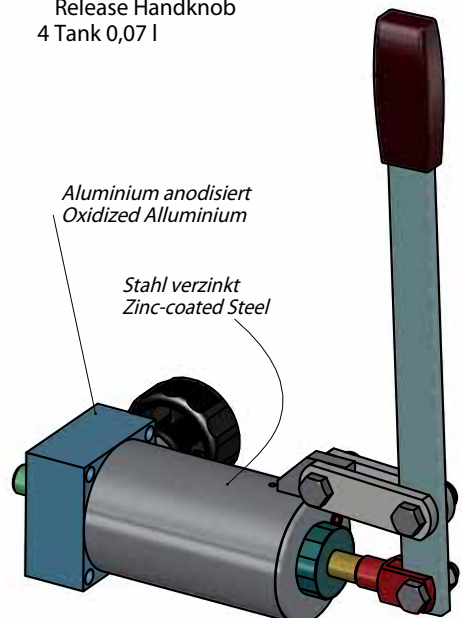
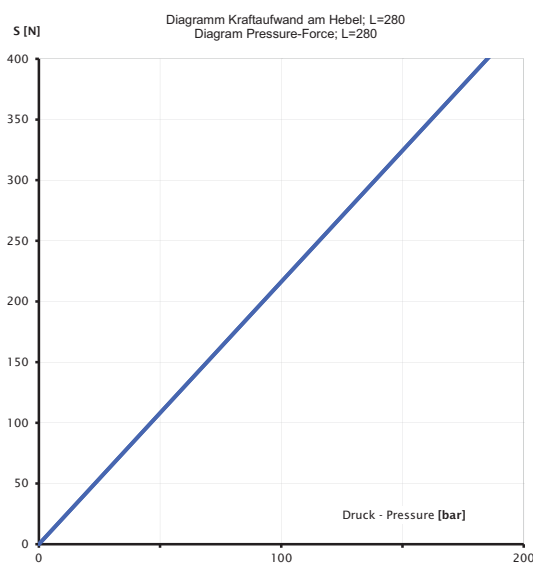

TYP TYPE	Fördervolumen Displacement [cm³]	Druck Pressure [bar]
GL12NG	2,8	180

*Unverbindliche Angaben. Änderungen vorbehalten. - Dimensions not binding. Modifications reserved without prior notice.  
Property of HANSA-TMP SRL. Copying without authorisation will be persecuted by Law.  
Eigentum von HANSA-TMP SRL. Nicht genehmigtes Kopieren wird strafrechtlich verfolgt.*

### Pumpe Typ GLDE7AL - Pump Type GLDE7AL

*Doppelhubfunktion für einfachwirkende Zylinder*  
*Double-stroke function for single acting cylinder*

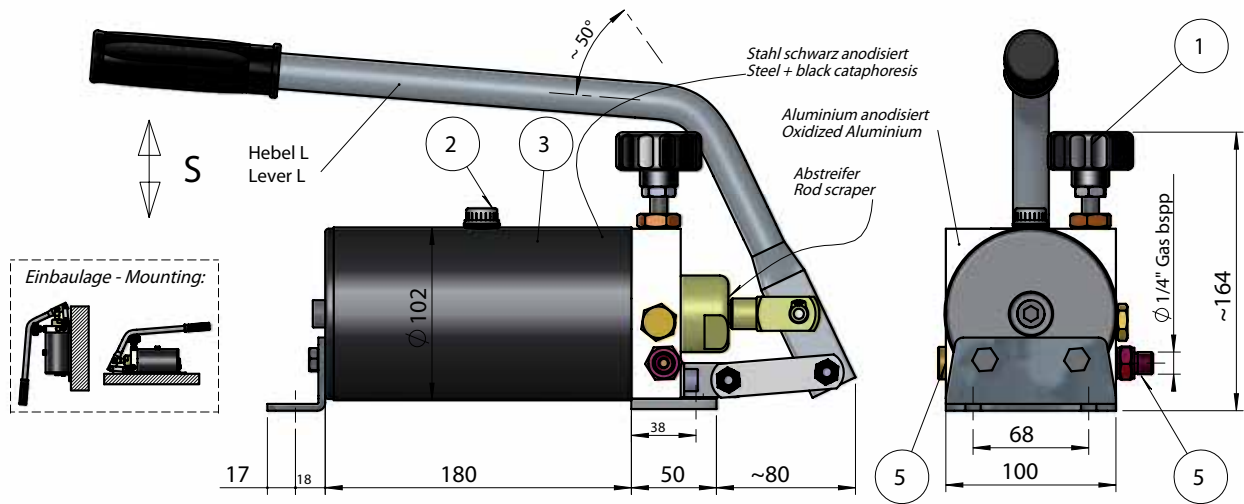

Gewicht - Weight ~6.5 [kg]

- 1 Ablasshandrad - Release handknob
- 2 Öl-Einfüllstopfen - Filler Plug
- 3 Tank 0.9 l\*
- 5 Druckanschluss - Pressure Port
- 6 Befestigungsbohrungen - Mounting holes
- 7 Druckbegrenzungsventil (auf Anfrage) - Relief valve (on request)

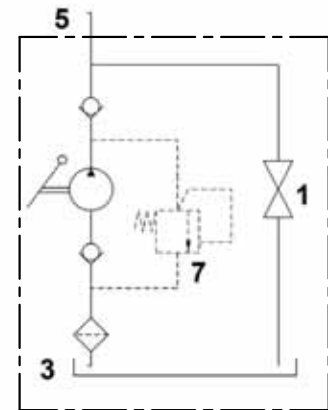
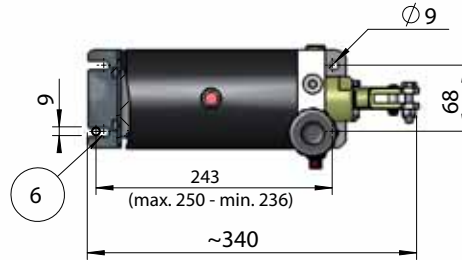

\* Lieferbar auch mit Tanks zu 1.5 bzw. 2.2 l  
Also available with tanks 1.5 l and 2.2 l

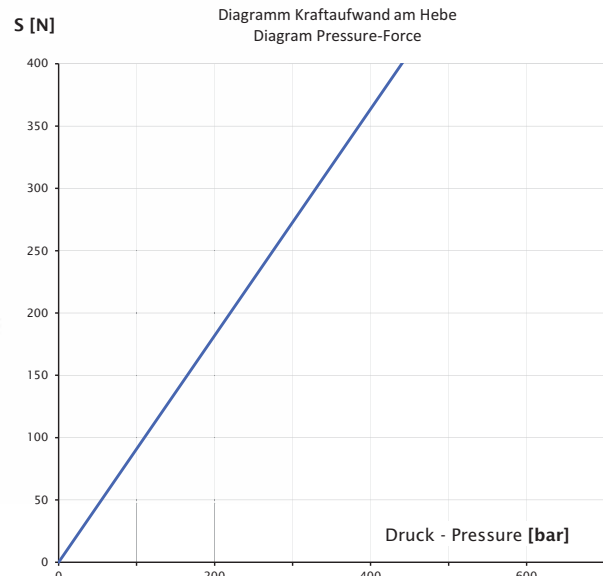
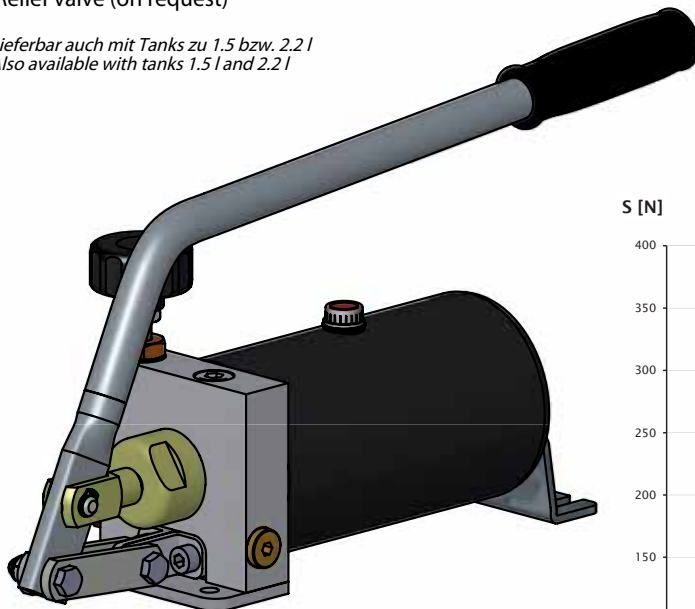

TYP TYPE	Fördervolumen Displacement [cm <sup>3</sup> ]	Druck Pressure [bar]
GLDE7AL	7	400

*Unverbindliche Angaben. Änderungen vorbehalten. - Dimensions not binding. Modifications reserved without prior notice.*  
*Property of HANSA-TMP SRL. Copying without authorisation will be persecuted by Law.*  
*Eigentum von HANSA-TMP SRL. Nicht genehmigtes Kopieren wird strafrechtlich verfolgt.*

### Pumpe Typ GLS-S1-VMRM - Pump Type GLS-S1-VMRM

*Doppelhubfunktion für einfachwirkende Zylinder  
Double-stroke function for single acting cylinder*

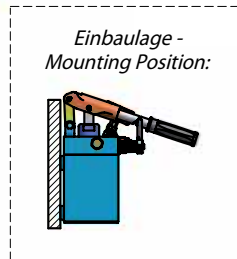
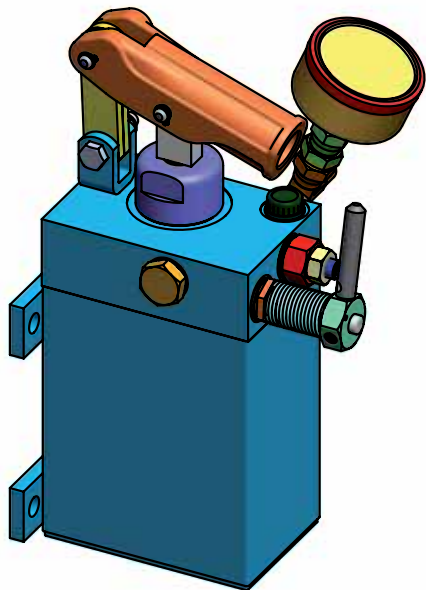
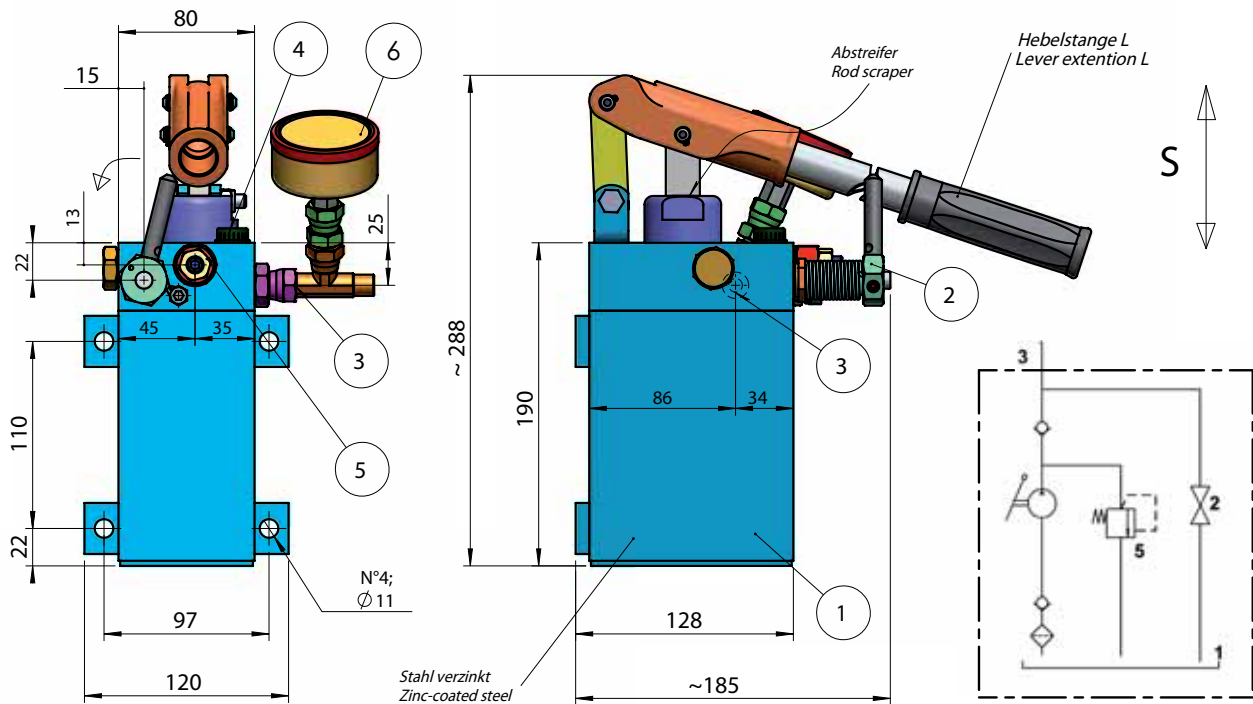

Gewicht - Weight ~7 [kg]

- 1 Tank 1 l
- 2 Ablass (normal geschlossen) - Release (normally closed)
- 3 Druckanschluss 1/4" Gas bspp - Pressure Port 1/4" Gas bspp
- 4 Öl-Einfüllstopfen - Filler Plug
- 5 Druckbegrenzungsventil - Relief valve
- 6 Manometer (auf Anfrage) - Pressure gauge (on request)

TYP TYPE	Fördervolumen Displacement [cm³]	Druck Pressure [bar]
GLS17-S1-VMRM	11	350
GLS20-S1-VMRM	16	250
GLS25-S1-VMRM	25	150
GLS28-S1-VMRM	32	130
GLS35-S1-VMRM	40	100

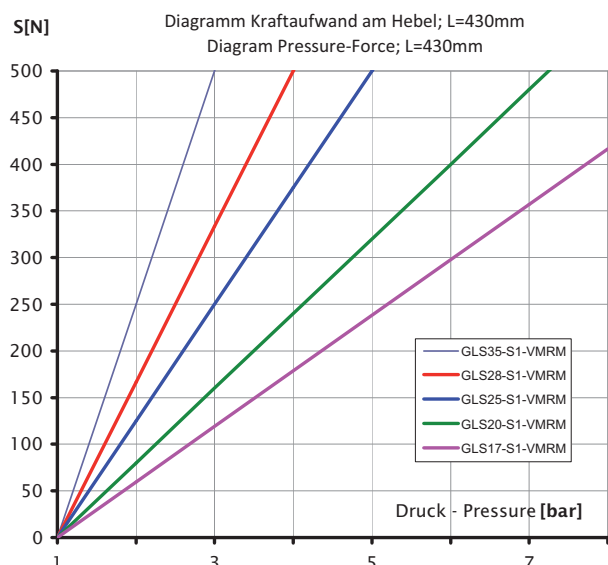

*Unverbindliche Angaben. Änderungen vorbehalten. - Dimensions not binding. Modifications reserved without prior notice.  
Property of HANSA-TMP SRL. Copying without authorisation will be persecuted by Law.  
Eigentum von HANSA-TMP SRL. Nicht genehmigtes Kopieren wird strafrechtlich verfolgt.*

### Pumpe Typ GL170M - Pump Type GL170M

*Doppelhubfunktion für einfachwirkende Zylinder*  
*Double-stroke function for single acting cylinders*

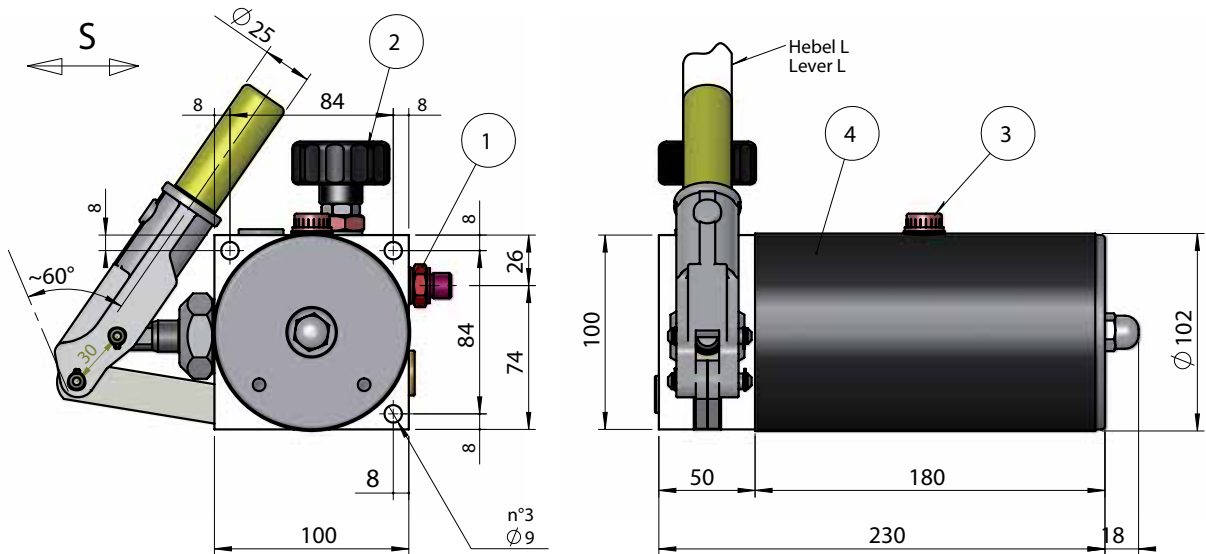

Gewicht - Weight ~5 [kg]

- 1 Druckanschluss 1/4" Gas bspp - Pressure port 1/4" Gas bspp
- 2 Ablassventil - Release hand knob
- 3 Öl-Einfüllstopfen - Filler plug
- 4 Tank 1 l

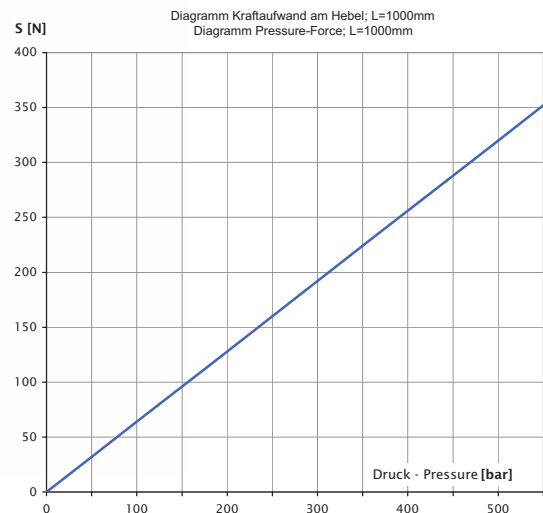
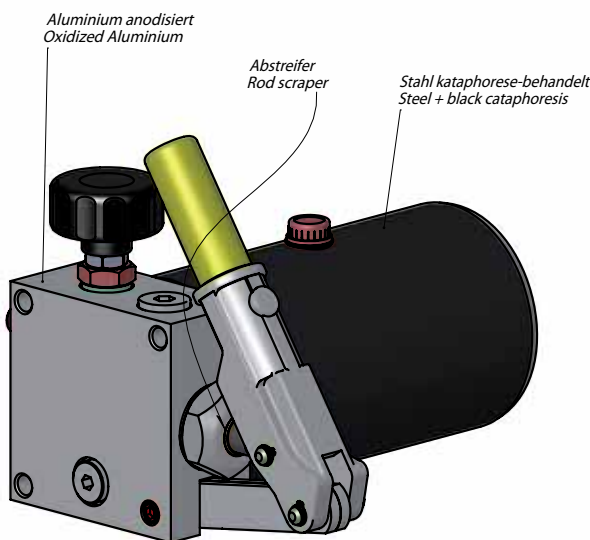
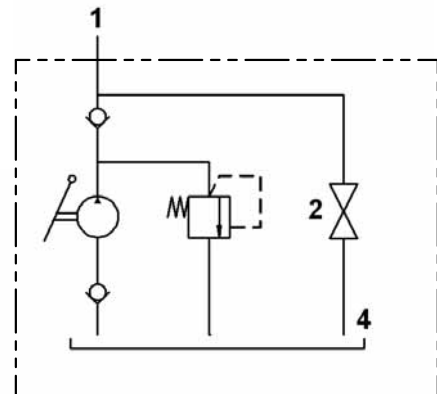
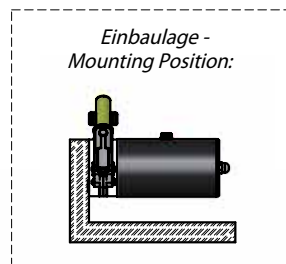

TYP TYPE	Fördervolumen Displacement [cm <sup>3</sup> ]	Druck Pressure [bar]
GL170M	14	500

*Unverbindliche Angaben. Änderungen vorbehalten. - Dimensions not binding. Modifications reserved without prior notice.*  
*Property of HANSA-TMP SRL. Copying without authorisation will be persecuted by Law.*  
*Eigentum von HANSA-TMP SRL. Nicht genehmigtes Kopieren wird strafrechtlich verfolgt.*

### Pumpe Typ GL207 - Pump Type GL207

*Doppelhubfunktion für doppeltwirkenden Zylinder*  
*Double-stroke function for double acting cylinders*

Gewicht - Weight ~12 [kg]

- 1 Tank 8 l
- 2 Öl-Einfüllstopfen - Filler Plug
- 3 Umschaltventil - Oil Flow Diverter Lever
- 4 Druckanschluss 1 (3/8" Gas bspp) - Pressure Port 1 (3/8" Gas bspp)
- 5 Druckanschluss 2 (3/8" Gas bspp) - Pressure Port 2 (3/8" Gas bspp)
- 6 Druckbegrenzungsventil - Relief Valve



Diagramm Kraftaufwand am Hebel, L=530mm  
Diagramm presse-Force L=530mm



TYP TYPE	Fördervolumen Displacement [cm³]	Druck Pressure [bar]
GL207-17	11	380
GL207-20	16	280
GL207-25	25	180
GL207-28	32	150
GL207-35	40	100

*Unverbindliche Angaben. Änderungen vorbehalten. - Dimensions not binding. Modifications reserved without prior notice.*  
*Property of HANSA-TMP SRL. Copying without authorisation will be persecuted by Law.*  
*Eigentum von HANSA-TMP SRL. Nicht genehmigtes Kopieren wird strafrechtlich verfolgt.*

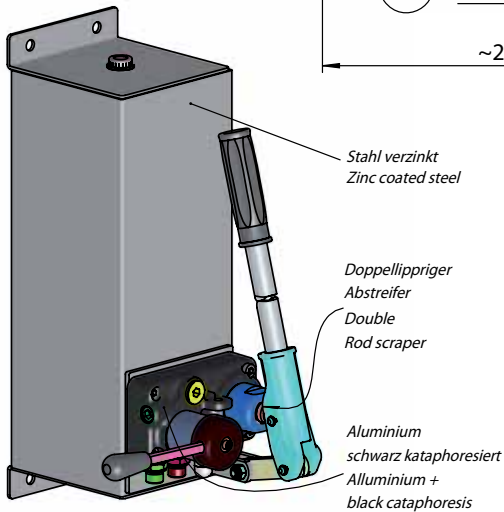
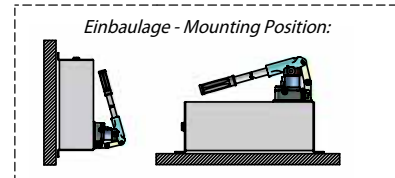
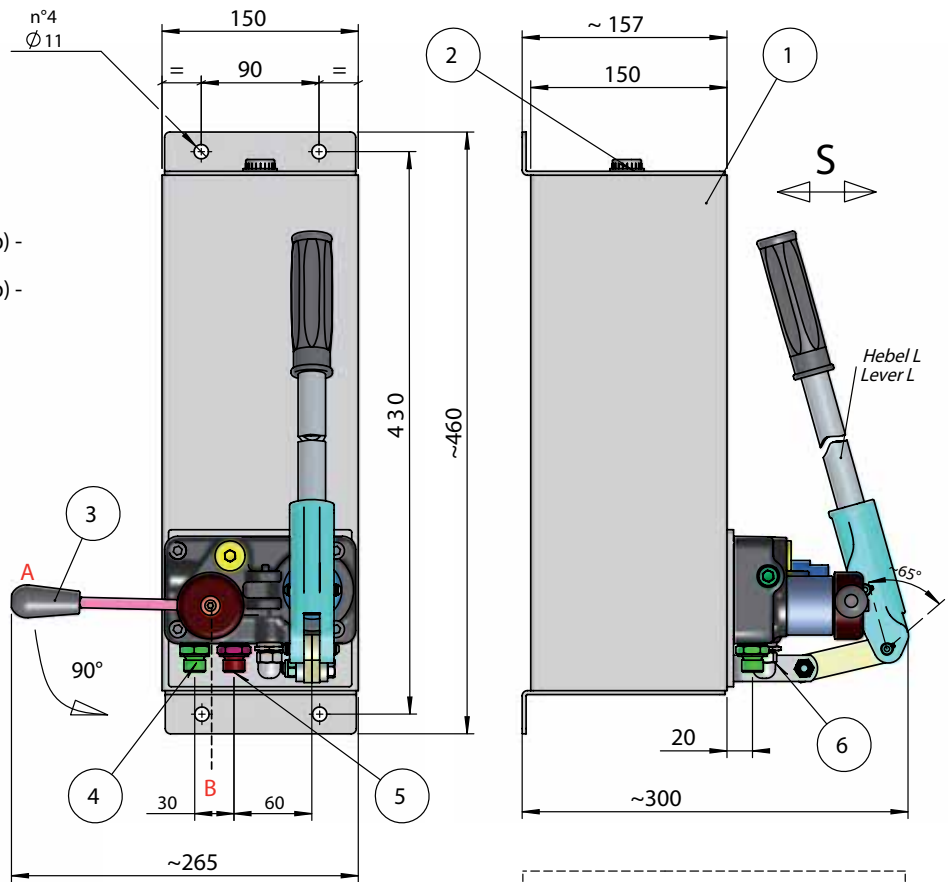
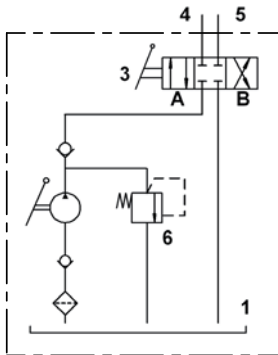
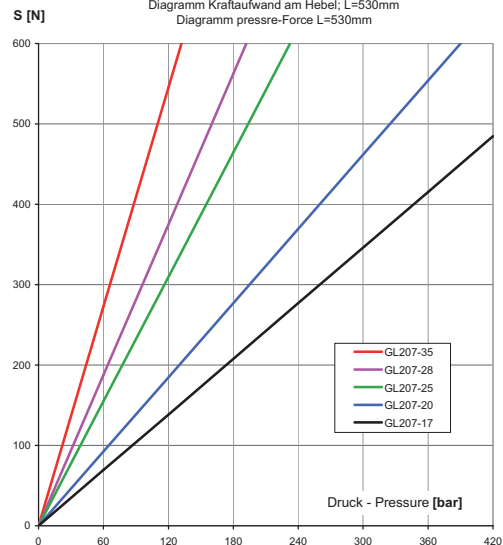

### Pumpe Typ GL286 - Pump Type GL286

*Doppelhub-Funktion für doppelwirkenden Differentialzylinder*  
*Double-stroke function for double acting differential cylinders*

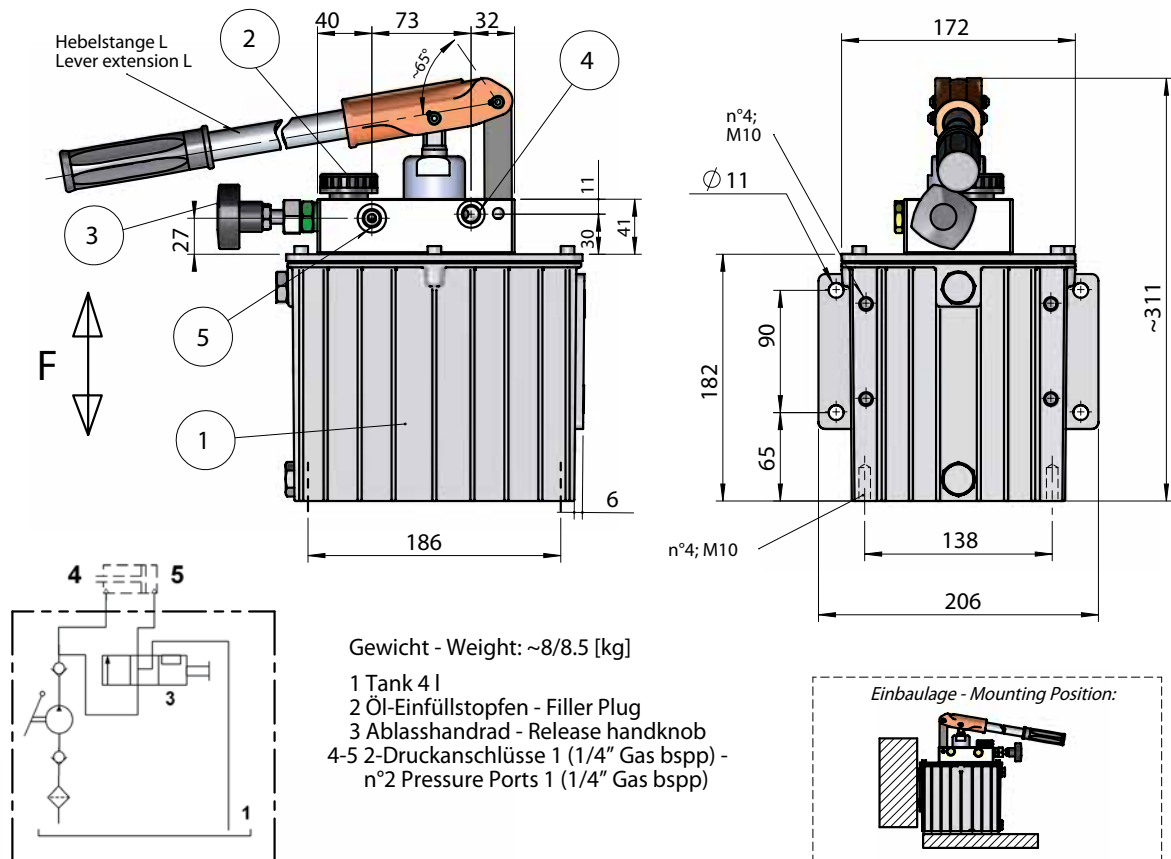

Gewicht - Weight: ~8/8.5 [kg]

- 1 Tank 4 l
- 2 Öl-Einfüllstopfen - Filler Plug
- 3 Ablasshandrad - Release handknob
- 4-5 2-Druckanschlüsse 1 (1/4" Gas bsp) - n°2 Pressure Ports 1 (1/4" Gas bsp)

Einbaulage - Mounting Position:

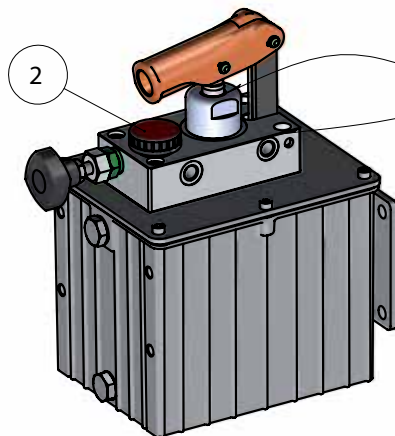
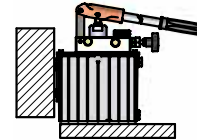

Doppellippriger Abstreifer  
Double Rod scraper

Aluminium anodisiert  
Oxidized aluminium

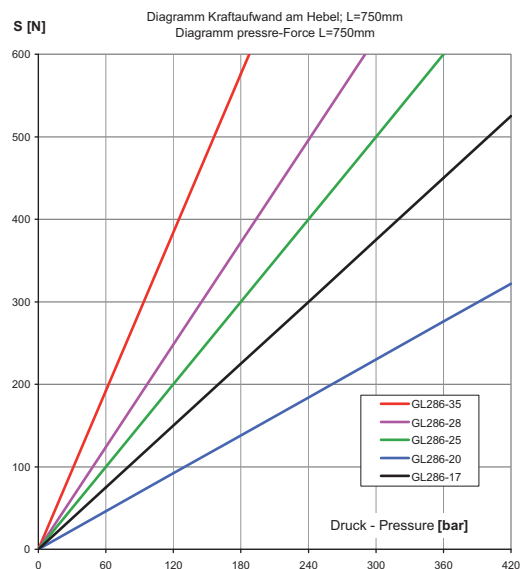

TYP TYPE	Fördervolumen Displacement [cm³]	Druck Pressure [bar]
GL286-17	11	380
GL286-20	16	280
GL286-25	25	180
GL286-28	32	150
GL286-35	40	100

Unverbindliche Angaben. Änderungen vorbehalten. - Dimensions not binding. Modifications reserved without prior notice.  
Property of HANSA-TMP SRL. Copying without authorisation will be persecuted by Law.  
Eigentum von HANSA-TMP SRL. Nicht genehmigtes Kopieren wird strafrechtlich verfolgt.

### Pumpe Typ GLDE17-IN-60 - Pump Type GLDE17-IN-60

*Doppelhubfunktion für einfachwirkende Zylinder*  
*Double-stroke function for single acting cylinder*

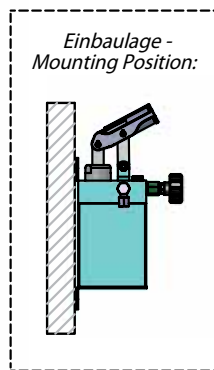
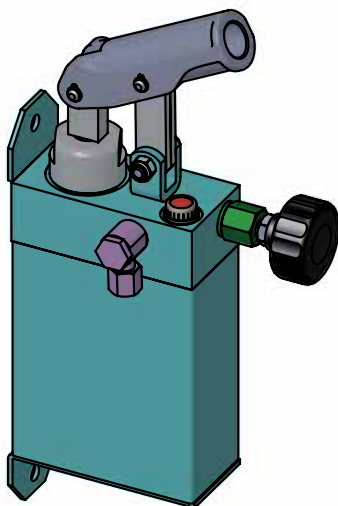
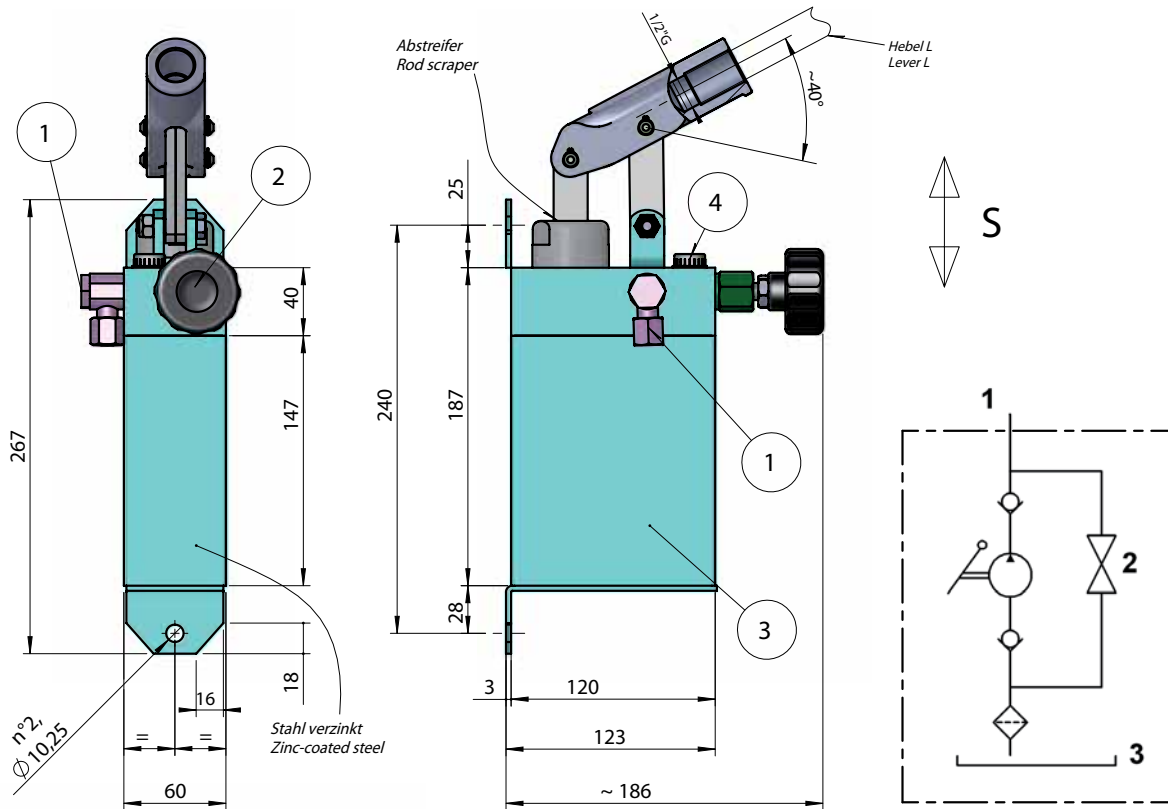

Gewicht - Weight ~6 [kg]

- 1 1/4" drehbarer Druckanschluss für Schlauch D. 8  
Pressure Port 1/4" swivel for pipe ø8
- 2 Ablasshandrad - Release Handknob
- 3 Tank 1,5 l
- 4 Öl-Einfüllstopfen - Filler Plug

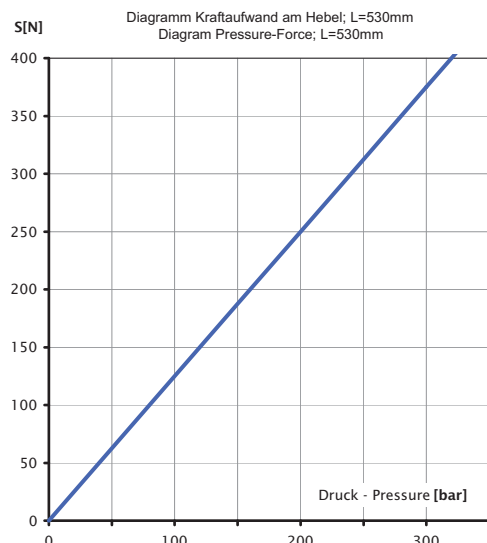

TYP TYPE	Fördervolumen Displacement [cm³]	Druck Pressure [bar]
GLDE17-IN-60	7	250

*Unverbindliche Angaben. Änderungen vorbehalten. - Dimensions not binding. Modifications reserved without prior notice.*  
*Property of HANSA-TMP SRL. Copying without authorisation will be persecuted by Law.*  
*Eigentum von HANSA-TMP SRL. Nicht genehmigtes Kopieren wird strafrechtlich verfolgt.*

### Pumpe Typ GL290 - Pump Type GL290

*Doppelhubfunktion mit integriertem Umschaltventil für doppelwirkende Zylinder*  
*Double-Stroke function with flow diverter included, for double cylinder*

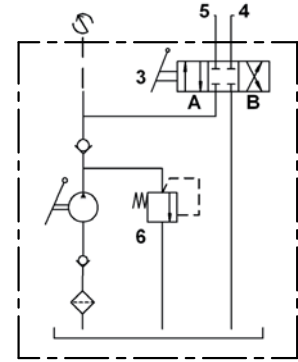
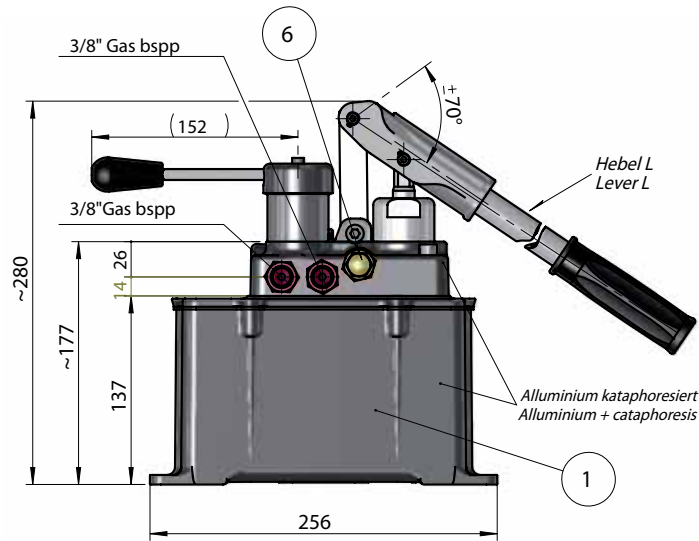

Gewicht - Weight ~6-6,5 [kg]

- 1 Tank 2,0 l
- 2 Öl-Einfüllstopfen - Filler Plug
- 3 Hebel Umschaltventil - Oil Flow Diverter Lever
- 4 Druckanschluss 1 - Pressure Port 1
- 5 Druckanschluss 2 - Pressure Port 2
- 6 Druckbegrenzungsventil - Relief Valve

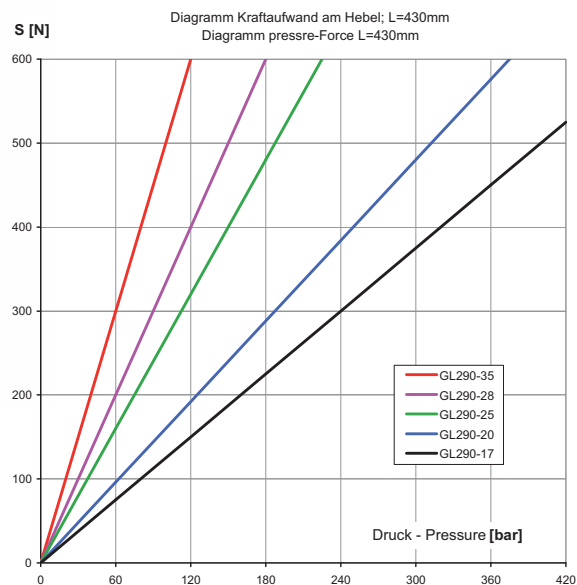
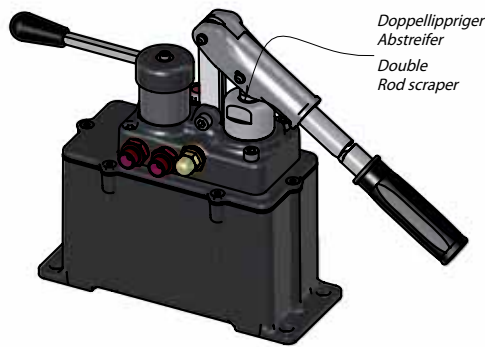
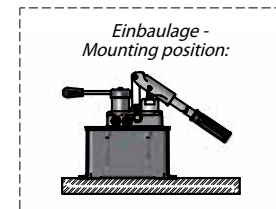
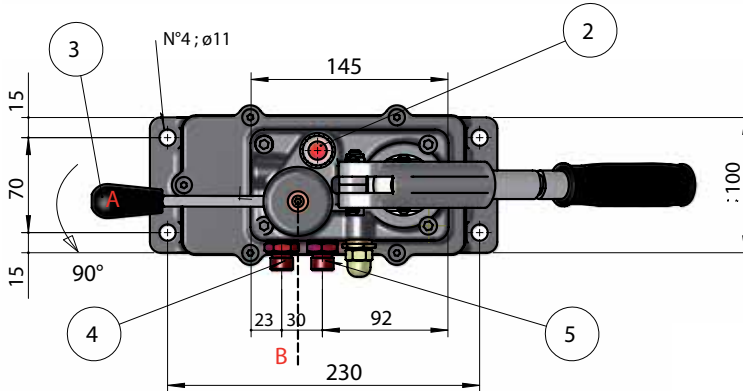

TYP TYPE	Fördervolumen Displacement [cm³]	Druck Pressure [bar]
GL290-17	11	380
GL290-20	16	280
GL290-25	25	180
GL290-28	32	150
GL290-35	40	100

*Unverbindliche Angaben. Änderungen vorbehalten. - Dimensions not binding. Modifications reserved without prior notice.*  
*Property of HANSA-TMP SRL. Copying without authorisation will be persecuted by Law.*  
*Eigentum von HANSA-TMP SRL. Nicht genehmigtes Kopieren wird strafrechtlich verfolgt.*

### Pumpe Typ GL290-4L - Pump Type GL290-4L

*Doppelhubfunktion mit integriertem Umschaltventil für doppelwirkende Zylinder*  
*Double-Stroke function with flow diverter included for double acting cylinder*

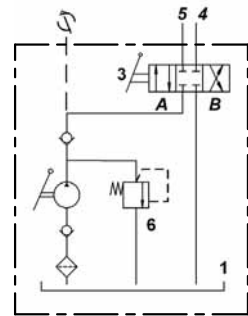
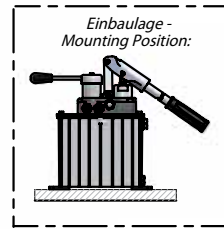
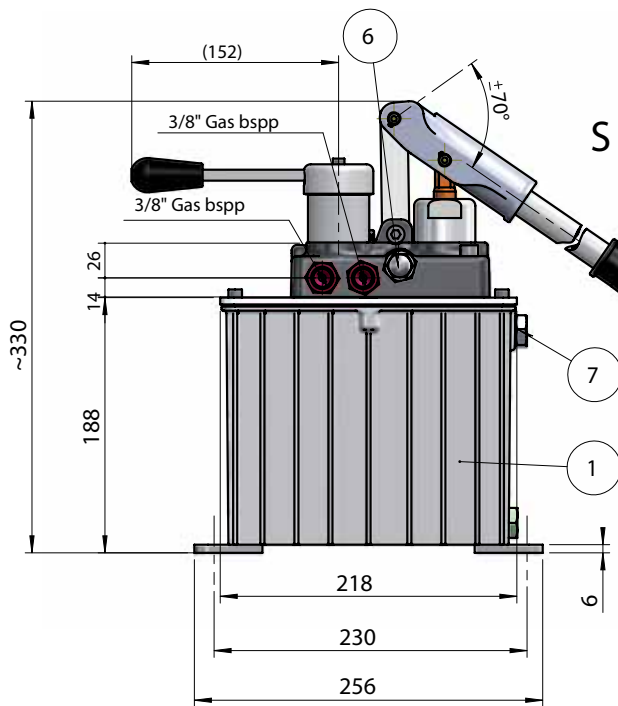

Gewicht - Weight ~7,5-8 [kg]

- 1 Tank 4 l
- 2 Öl-Einfüllstopfen - Filler Plug
- 3 Hebel Umschaltventil - Oil Flow Diverter Lever
- 4 Druckanschluss 1 - Pressure Port 1
- 5 Druckanschluss 2 - Pressure Port 2
- 6 Druckbegrenzungsventil - Relief Valve
- 7 Ölstandsanzeige - Oil Level

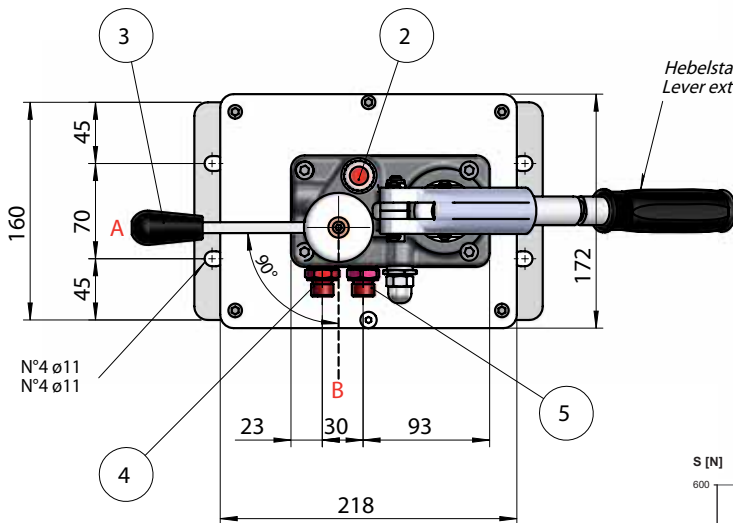

Hebelstange L  
Lever extension L

Doppellippriger Abstreifer  
Double Rod scraper

Alluminium kataphoresiert  
Aluminium + cathoresis

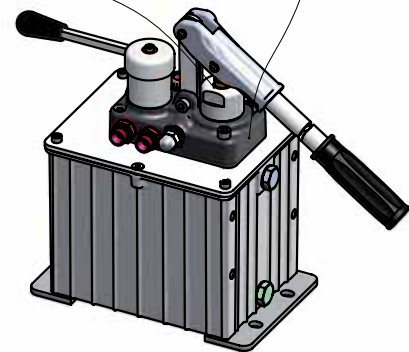

TYP TYPE	Fördervolumen Displacement [cm³]	Druck Pressure [bar]
GL290-17-4L	11	380
GL290-20-4L	16	280
GL290-25-4L	25	180
GL290-28-4L	32	150
GL290-35-4L	40	100

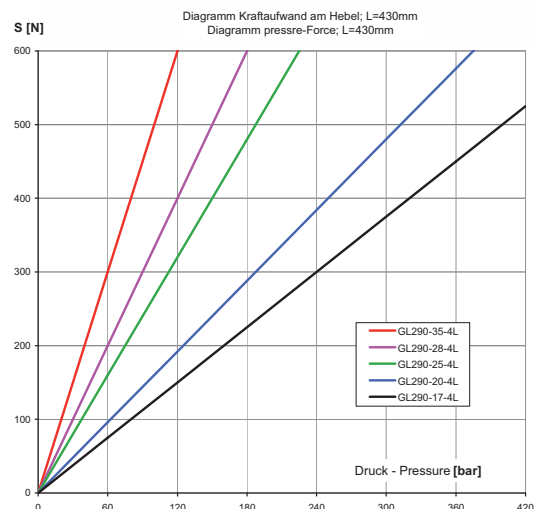

*Unverbindliche Angaben. Änderungen vorbehalten. - Dimensions not binding. Modifications reserved without prior notice.*  
*Property of HANSA-TMP SRL. Copying without authorisation will be persecuted by Law.*  
*Eigentum von HANSA-TMP SRL. Nicht genehmigtes Kopieren wird strafrechtlich verfolgt.*

### Pumpe Typ GL292 - Pump Type GL292

*Doppelhubfunktion für einfachwirkende Zylinder*  
*Double-Stroke function for single acting cylinder*

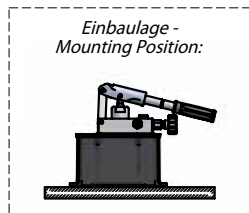
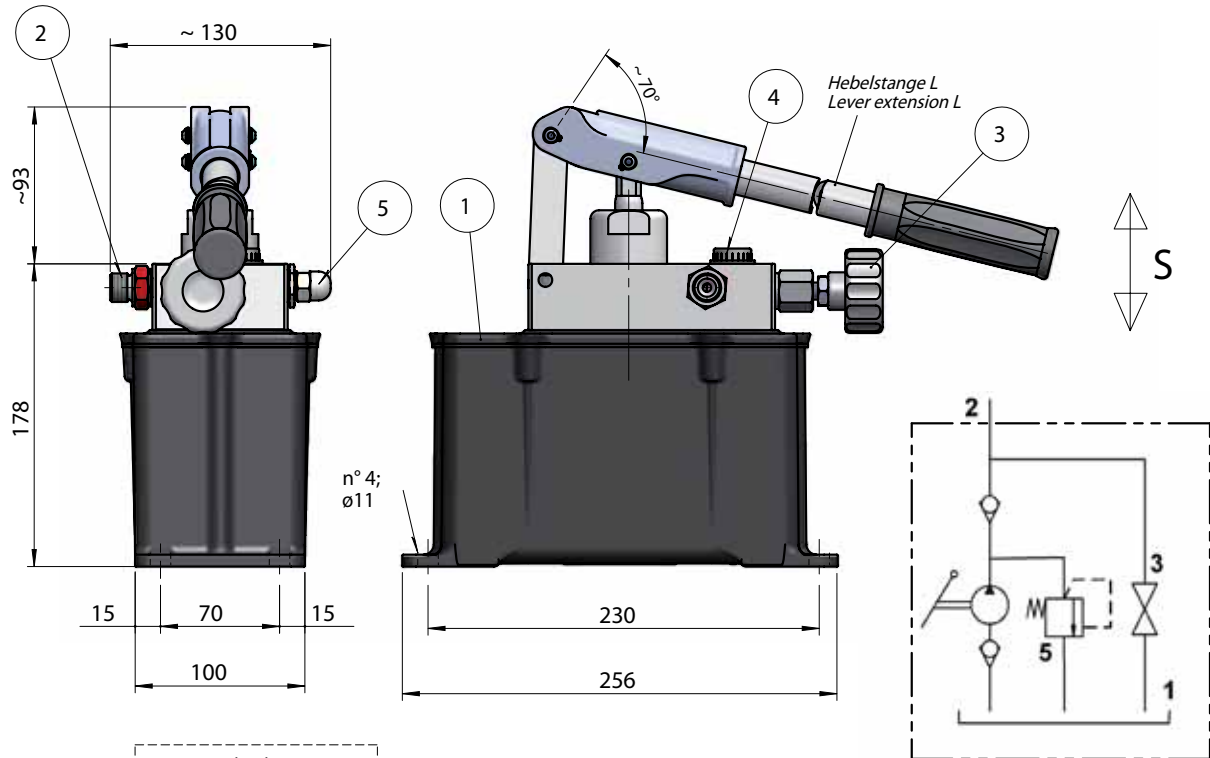

Gewicht - Weight ~5.8-6.3 [kg]

- 1 Tank 2 l
- 2 Druckanschluss 3/8" Gas bsp - Pressure Port 3/8" Gas bsp
- 3 Ablasshandrad - Release Handknob
- 4 Öl-Einfüllstopfen - Filler Plug
- 5 Druckbegrenzungsventil - Relief valve

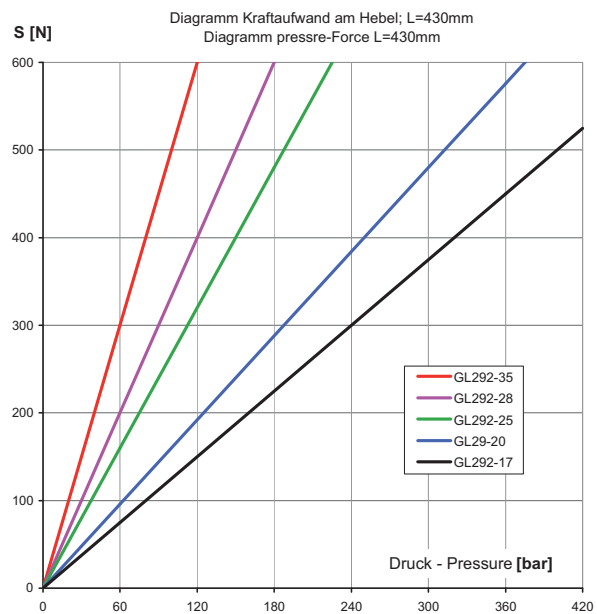
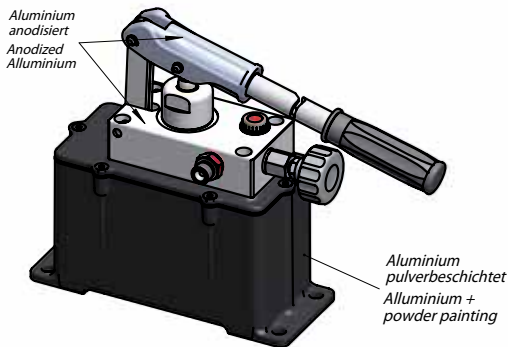

TYP TYPE	Fördervolumen Displacement [cm³]	Druck Pressure [bar]
GL292-17	11	380
GL292-20	16	280
GL292-25	25	180
GL292-28	32	150
GL292-35	40	100

*Unverbindliche Angaben. Änderungen vorbehalten. - Dimensions not binding. Modifications reserved without prior notice.*  
*Property of HANSA-TMP SRL. Copying without authorisation will be persecuted by Law.*  
*Eigentum von HANSA-TMP SRL. Nicht genehmigtes Kopieren wird strafrechtlich verfolgt.*

### Pumpe Typ GL292-4L - Pump Type GL292-4L

*Doppelhubfunktion für einfachwirkende Zylinder*  
*Double-Stroke function for single acting cylinder*

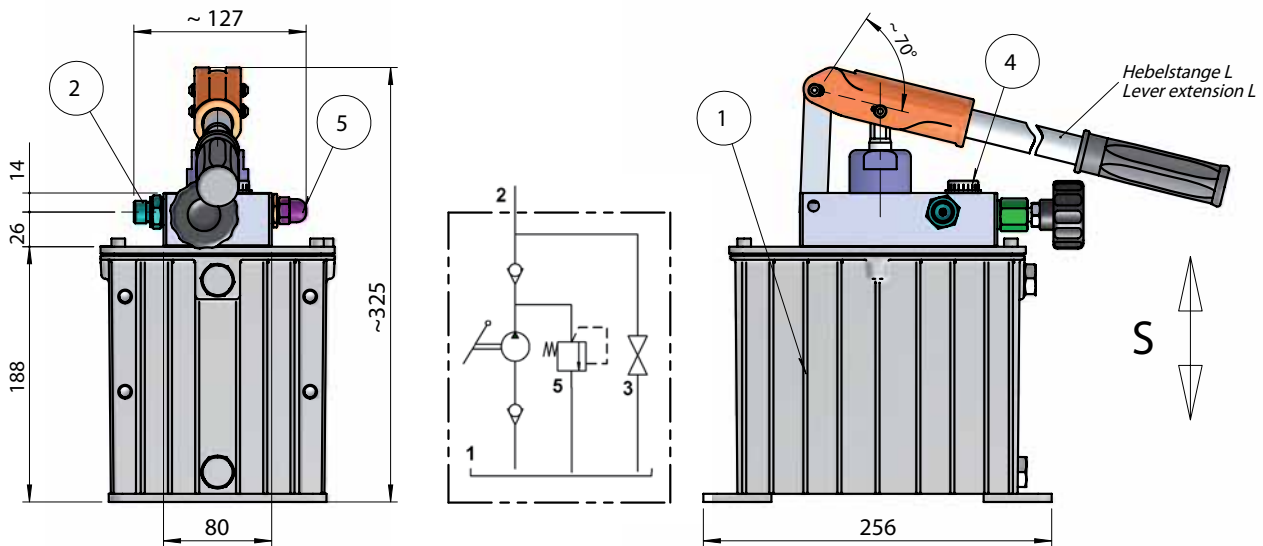

Gewicht - Weight ~8-8.5 [kg]

- 1 Tank 4 l
- 2 Druckanschluss 3/8" Gas bspp - Pressure Port 3/8" Gas bspp
- 3 Ablasshandrad - Release Handknob
- 4 Öl-Einfüllstopfen - Filler Plug
- 5 Druckbegrenzungsventil - Relief Valve

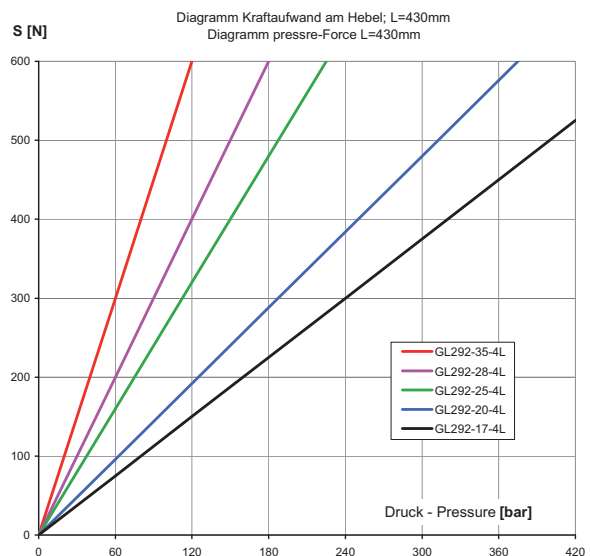
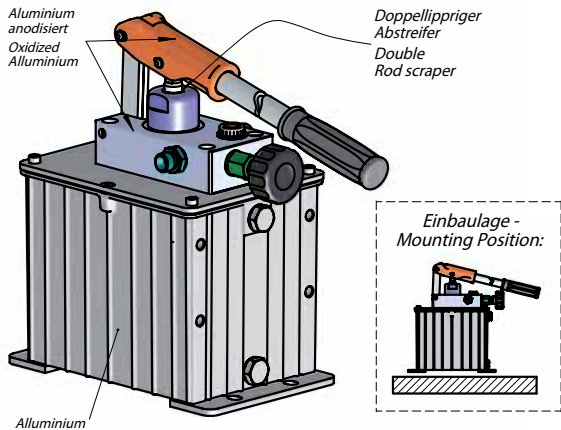
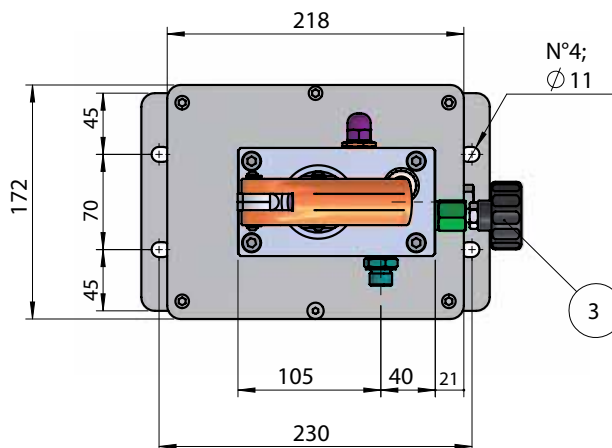

TYP TYPE	Fördervolumen Displacement [cm <sup>3</sup> ]	Druck Pressure [bar]
GL292-17-4L	11	380
GL292-20-4L	16	280
GL292-25-4L	25	180
GL292-28-4L	32	150
GL292-35-4L	40	100

*Unverbindliche Angaben. Änderungen vorbehalten. - Dimensions not binding. Modifications reserved without prior notice.*  
*Property of HANSA-TMP SRL. Copying without authorisation will be persecuted by Law.*  
*Eigentum von HANSA-TMP SRL. Nicht genehmigtes Kopieren wird strafrechtlich verfolgt.*



### Pumpe Typ PMS31AL - Pump Type PMS31AL

*Doppelhubfunktion für einfachwirkende Zylinder*  
*Double-stroke function for single acting cylinder*

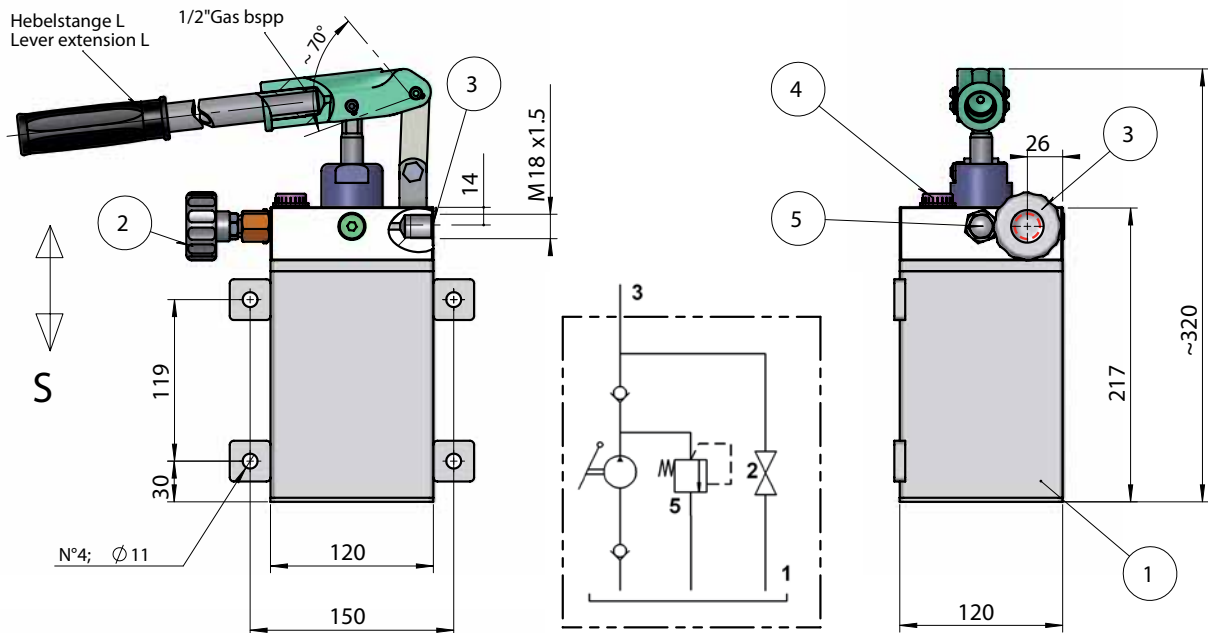

Gewicht - Weight ~6-6.3 [kg]

- 1 Tank 1,6 l
- 2 Ablass-Handrad (mit Venti I gehärtet und geschliffen) - Release Handknob (with hardened and polished valve)
- 3 Druckanschluss - Pressure Port
- 4 Öl-Einfüllstopfen - Filler Plug
- 5 Druckbegrenzungsventil - Relief Valve

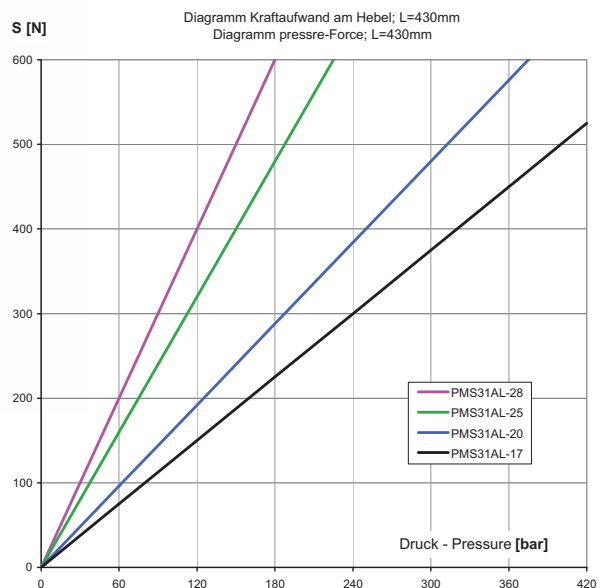
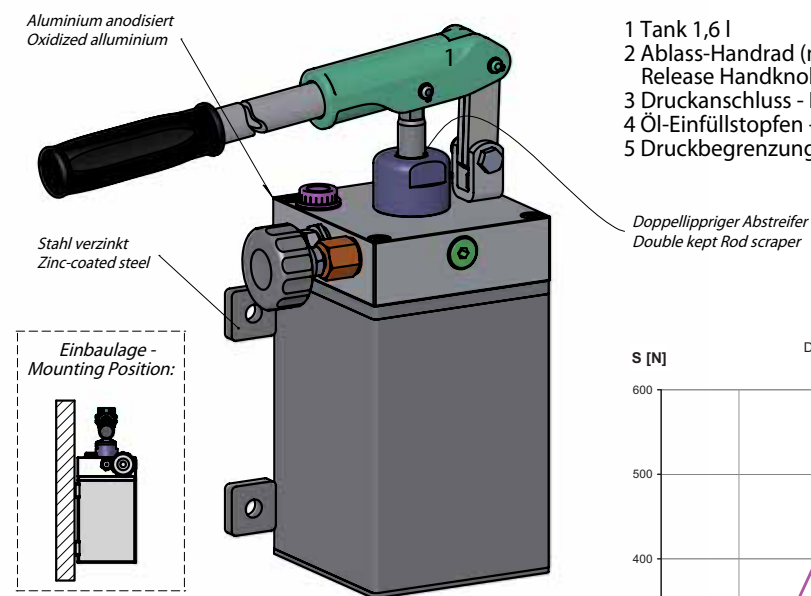

TYP TYPE	Fördervolumen Displacement [cm³]	Druck Pressure [bar]
PMS31AL-17	11	380
PMS31AL-20	16	280
PMS31AL-25	25	180
PMS31AL-28	32	150

*Unverbindliche Angaben. Änderungen vorbehalten. - Dimensions not binding. Modifications reserved without prior notice.*  
*Property of HANSA-TMP SRL. Copying without authorisation will be persecuted by Law.*  
*Eigentum von HANSA-TMP SRL. Nicht genehmigtes Kopieren wird strafrechtlich verfolgt.*



### Pumpe Typ GL16ALL - Pump Type GL16ALL

Einfach-Hubfunktion für einfachwirkende Zylinder  
Single acting function for single acting cylinder

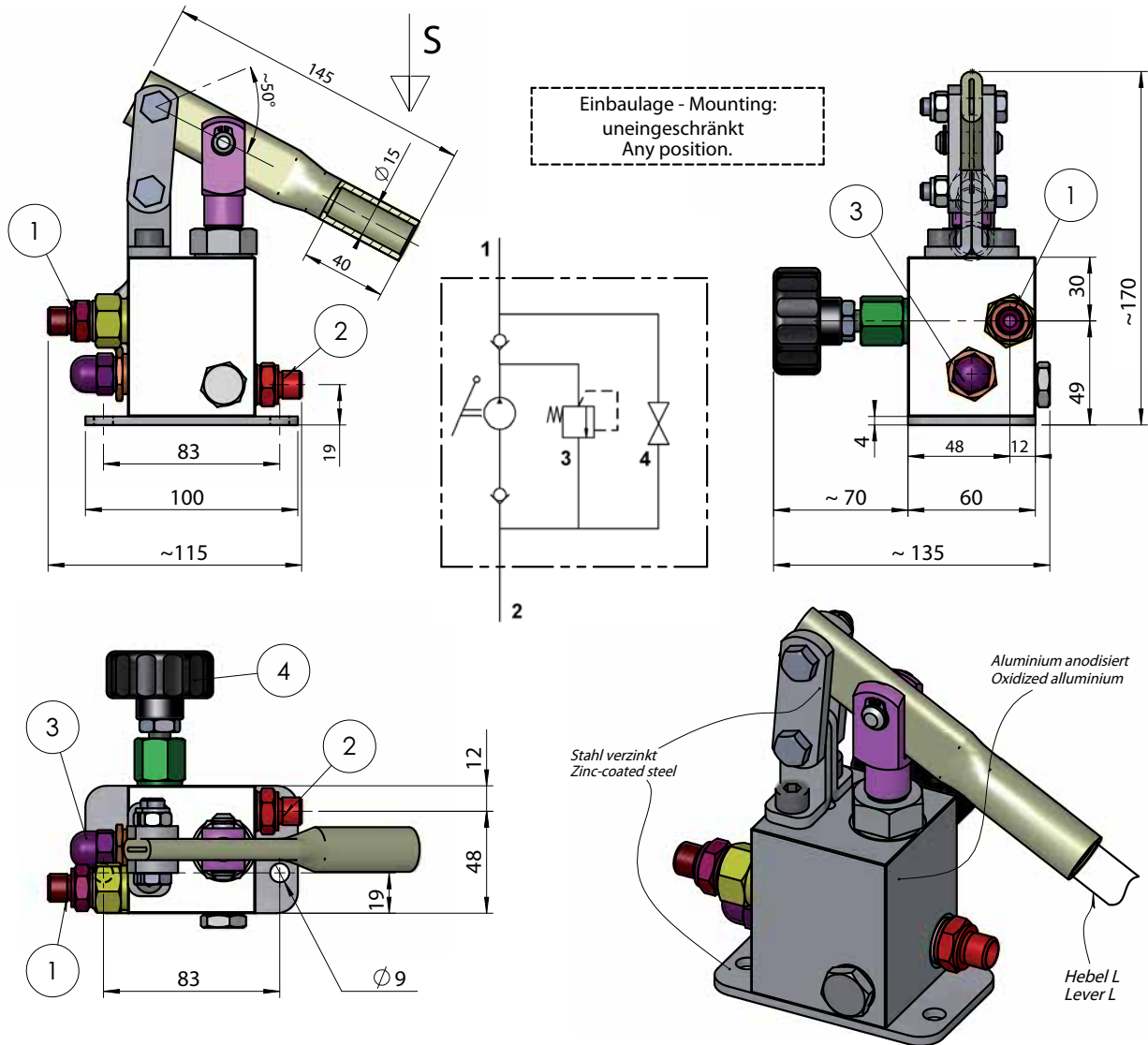

Gewicht - Weight: ~1.7 [kg]

- 1 Druckanschluss 1/4" Gas bsp - Pressure Port 1/4" Gas bsp
- 2 Sauganschluss 1/4" Gas bsp - Suction Port 1/4" Gas bsp
- 3 Druckbegrenzungsventil - Relief valve
- 4 Ablasshandrad - Release Handknob

\* Ventile gehärtet und geschliffen  
\* Hardened and polished valves

TYP TYPE	Fördervolumen Displacement [cm³]	Druck Pressure [bar]
GL16ALL	5,5	250

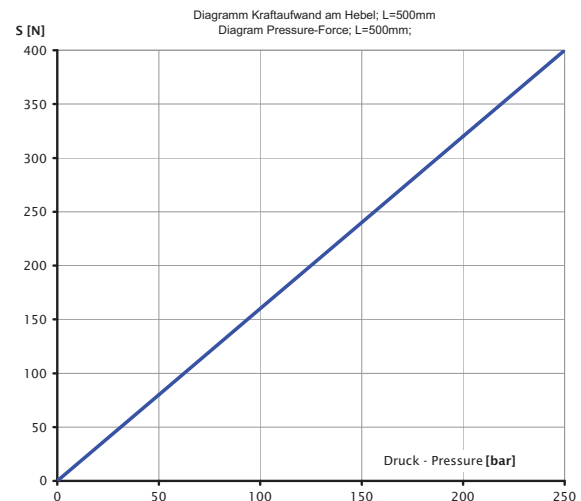

Unverbindliche Angaben. Änderungen vorbehalten. - Dimensions not binding. Modifications reserved without prior notice.  
Property of HANSA-TMP SRL. Copying without authorisation will be persecuted by Law.  
Eigentum von HANSA-TMP SRL. Nicht genehmigtes Kopieren wird strafrechtlich verfolgt.

### Pumpe Typ GL111M - Pump Type GL111M

*Einfach-Hubfunktion für einfachwirkende Zylinder*  
*Single-acting function for single acting cylinder*

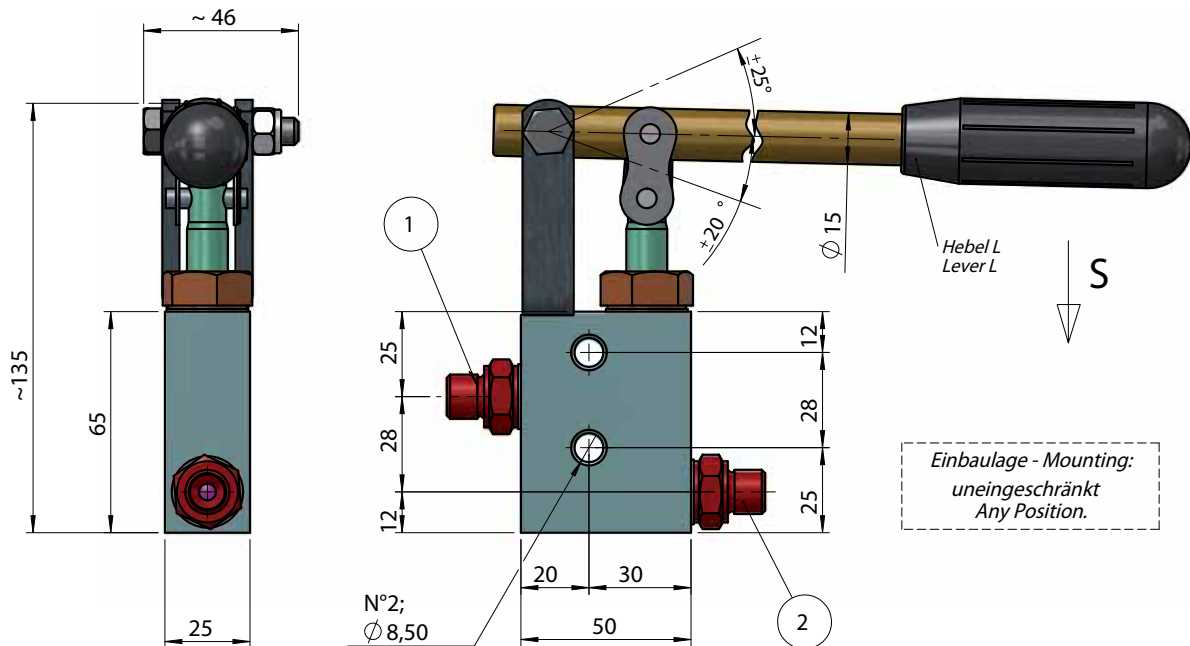

Gewicht - Weight ~1,0 [kg]

1 Druckanschluss 1/4" Gas bsp - Pressure Port 1/4" Gas bsp  
2 Sauganschluss 1/4" Gas bsp - Suction Port 1/4" Gas bsp

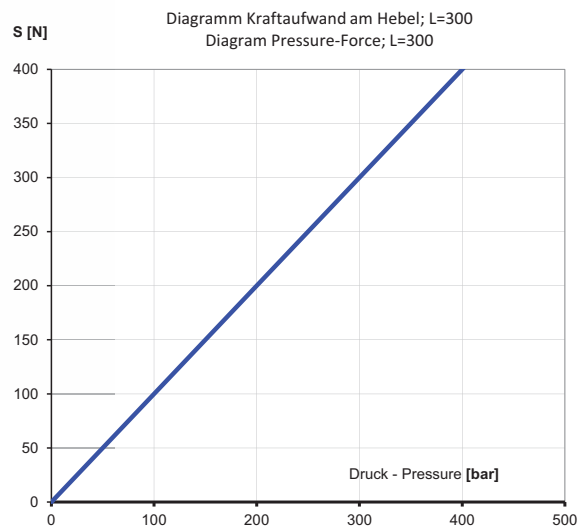
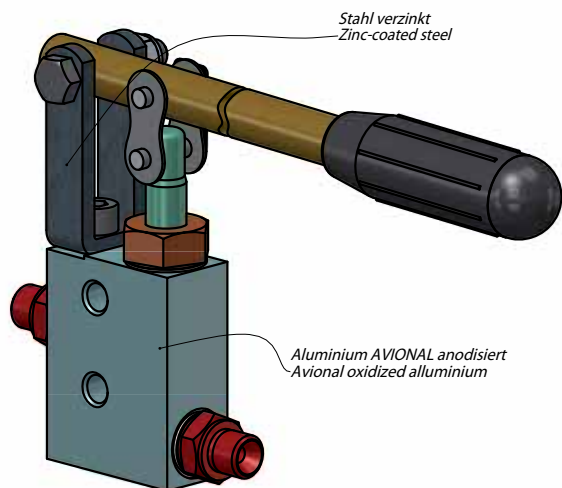
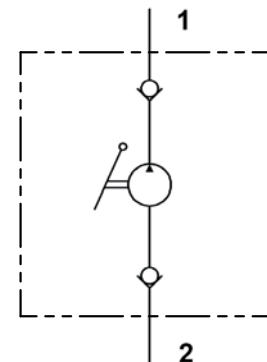

TYP TYPE	Fördervolumen Displacement [cm <sup>3</sup> ]	Druck Pressure [bar]
GL111M	2,5	400

*Unverbindliche Angaben. Änderungen vorbehalten. - Dimensions not binding. Modifications reserved without prior notice.*  
*Property of HANSA-TMP SRL. Copying without authorisation will be persecuted by Law.*  
*Eigentum von HANSA-TMP SRL. Nicht genehmigtes Kopieren wird strafrechtlich verfolgt.*

### Pumpe Typ GL111M-750 - Pump Type GL111M-750

Einfach-Hubfunktion für einfachwirkende Zylinder  
Single-acting function for single acting cylinder

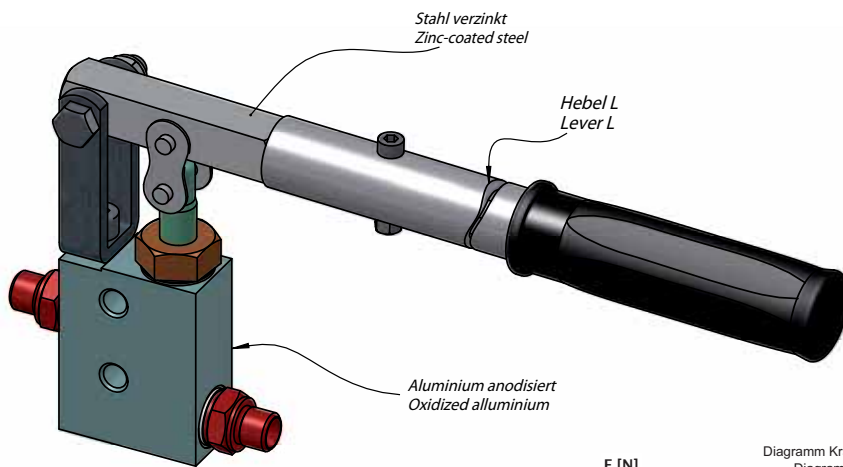
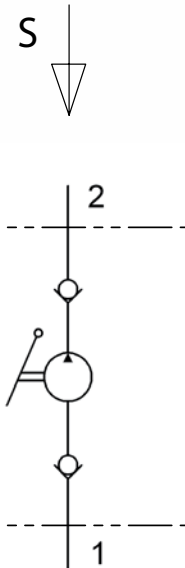
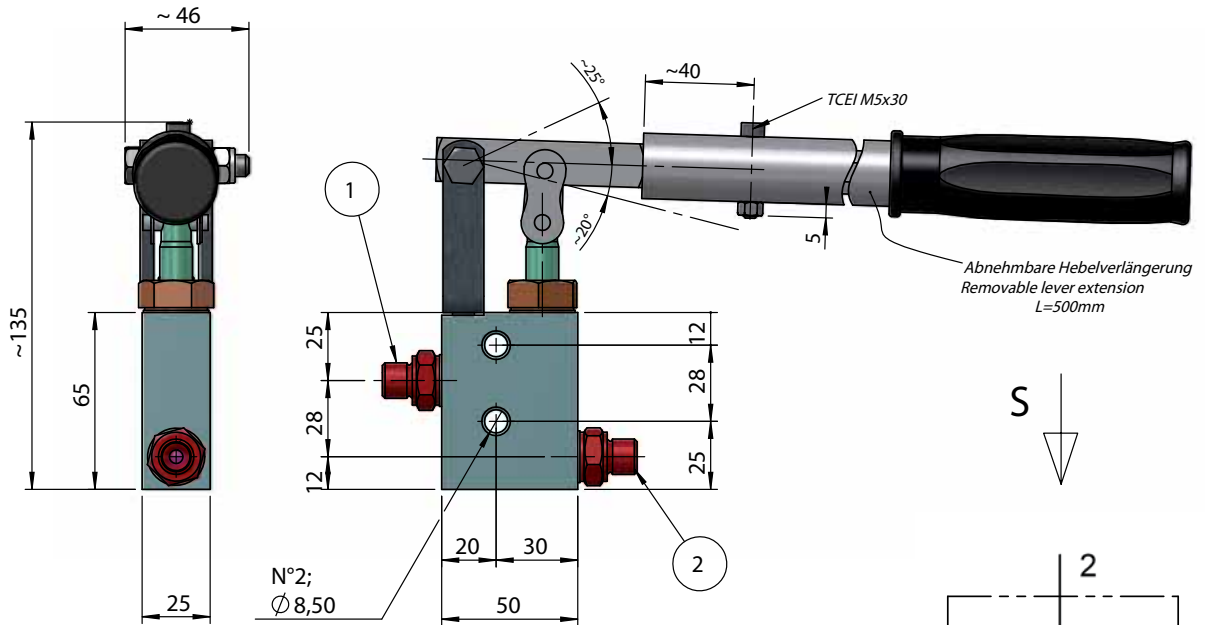

Gewicht - Weight ~2 [kg]

- 1 Druckanschluss 1/4" Gas bspp - Pressure Port 1/4" Gas bspp
- 2 Sauganschluss 1/4" Gas bspp - Suction Port 1/4" Gas bspp

TYP TYPE	Fördervolumen Displacement [cm³]	Druck Pressure [bar]
GL111M-750	2,5	700

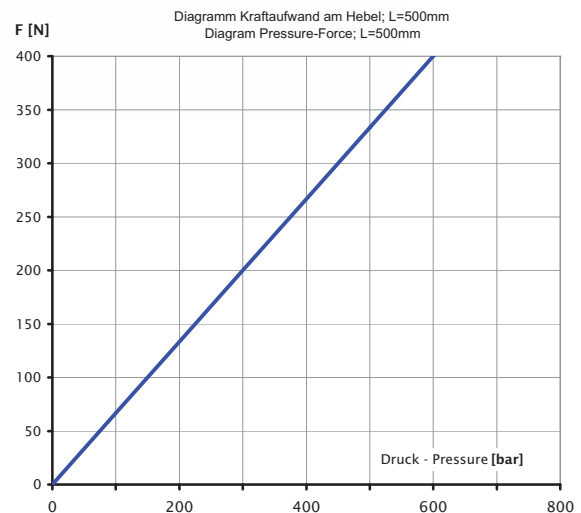

Unverbindliche Angaben. Änderungen vorbehalten. - Dimensions not binding. Modifications reserved without prior notice.  
Property of HANSA-TMP SRL. Copying without authorisation will be persecuted by Law.  
Eigentum von HANSA-TMP SRL. Nicht genehmigtes Kopieren wird strafrechtlich verfolgt.

### Pumpe Typ GL246 - Pump Type GL246

Einfach-Hubfunktion für einfachwirkende Zylinder  
Single acting function for single acting cylinder

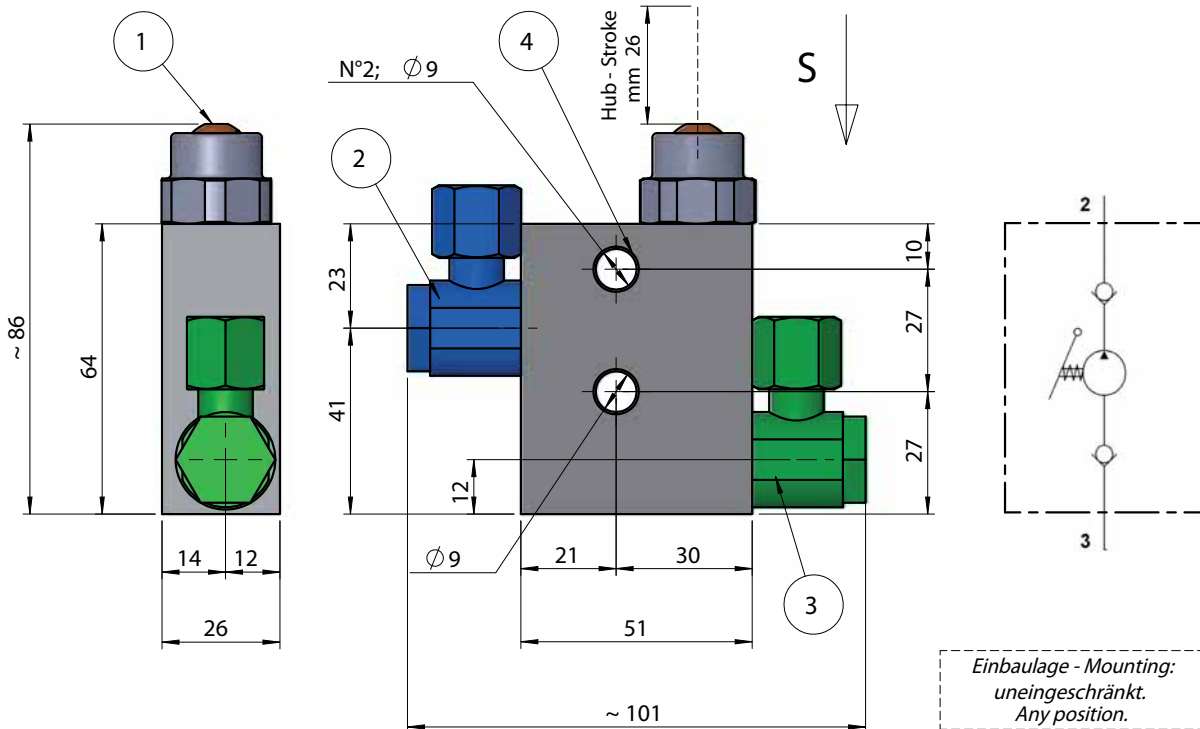

Gewicht - Weight ~0,4 Kg

- 1 Pumpkolben - Piston
- 2 Druckanschluss TN131-8LR-1.4-90 (1/4" Bsppl 90° für Schlauch Durchm. 8 mm)  
Pressure port TN131-8LR-1.4-90 (1/4" Gas Bsppl, 90° swivel for ø8 pipe)
- 3 Sauganschluss TN131-8LR-1.4-90 (1/4" Bsppl 90° für Schlauch Durchm. 8 mm)  
Suction port TN131-8LR-1.4-90 (1/4" Gas Bsppl, 90° swivel for ø8 pipe)
- 4 Befestigungsbohrungen - Mounting Holes

Aluminium anodisiert  
Oxidized Aluminum

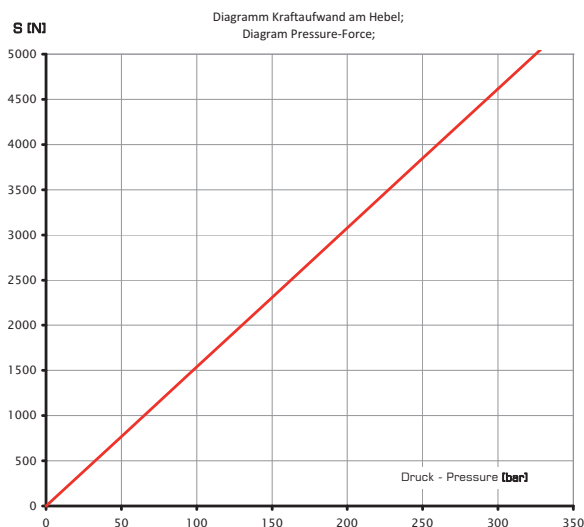
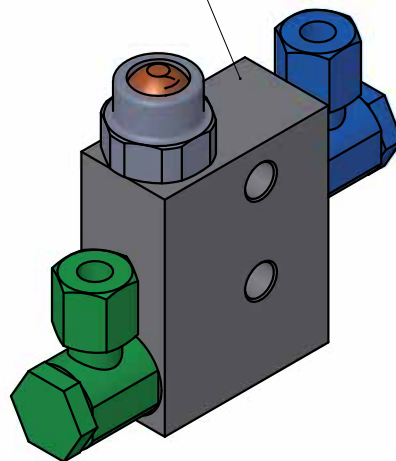

TYP TYPE	Fördervolumen Displacement [cm <sup>3</sup> ]	Druck Pressure [bar]
GL246	4	200

Unverbindliche Angaben. Änderungen vorbehalten. - Dimensions not binding. Modifications reserved without prior notice.  
Property of HANSA-TMP SRL. Copying without authorisation will be persecuted by Law.  
Eigentum von HANSA-TMP SRL. Nicht genehmigtes Kopieren wird strafrechtlich verfolgt.

### Pumpe Typ GLSE16 - Pump Type GLSE16

Einfach-Hubfunktion für einfachwirkende Zylinder  
Single-Acting function for single acting cylinder

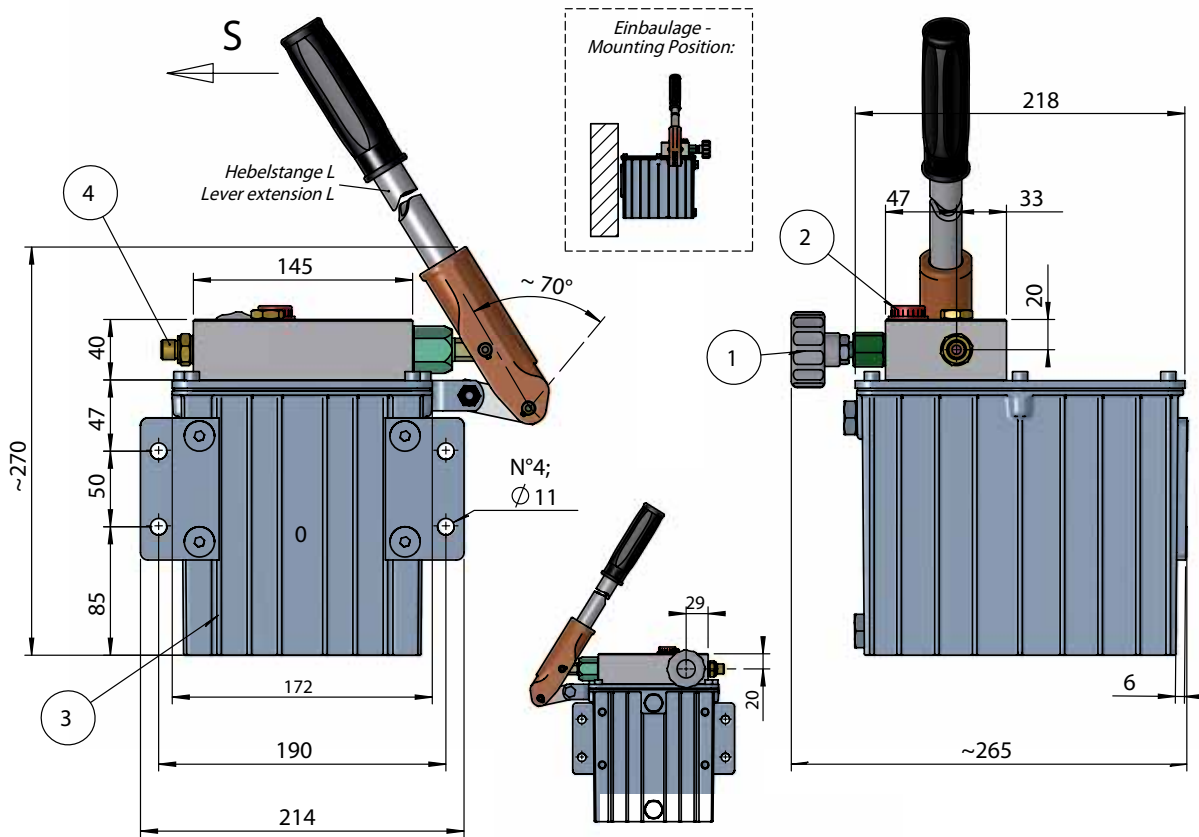

Gewicht - Weight Kg. ~7.5

- 1 Ablasshandrad - Release Handknob
- 2 Öl-Einfüllstopfen - Filler Plug
- 3 Tank 4 l
- 4 Druckanschluss 1/4" Gas bsp - Pressure Port 1/4" Gas bsp

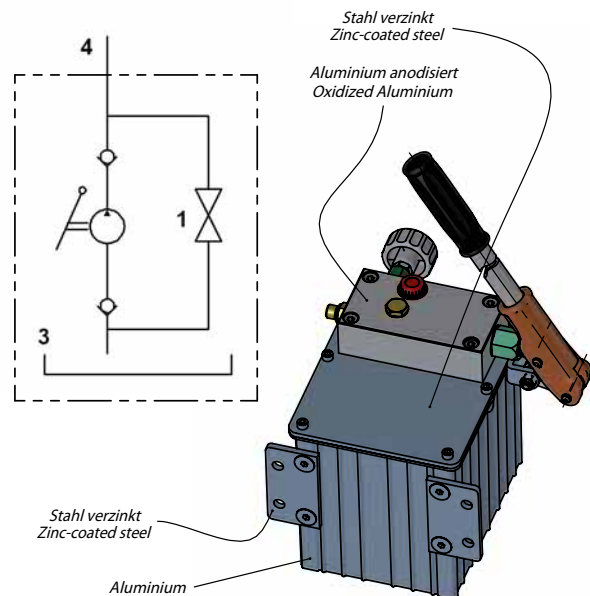
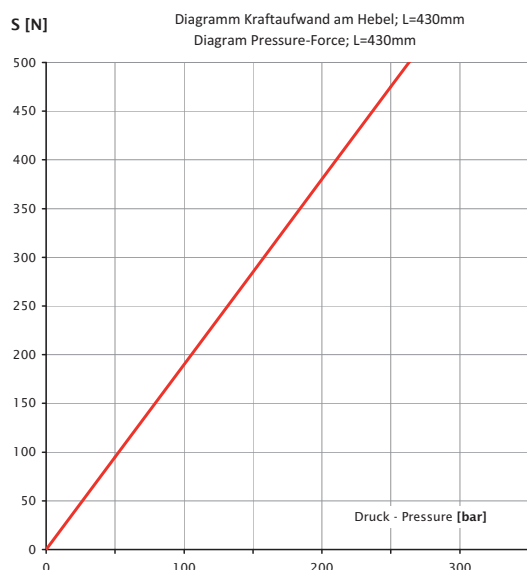

TYPE	Fördervolumen Displacement [cm <sup>3</sup> ]	Druck Pressure [bar]
GLSE16-ALL	11	200

Unverbindliche Angaben. Änderungen vorbehalten. - Dimensions not binding. Modifications reserved without prior notice.  
Property of HANSA-TMP SRL. Copying without authorisation will be persecuted by Law.  
Eigentum von HANSA-TMP SRL. Nicht genehmigtes Kopieren wird strafrechtlich verfolgt.

### Pumpe Typ GL1VAL - Pump Type GL1VAL

Einfach-Hubfunktion für einfachwirkende Zylinder  
Single acting function for single acting cylinder

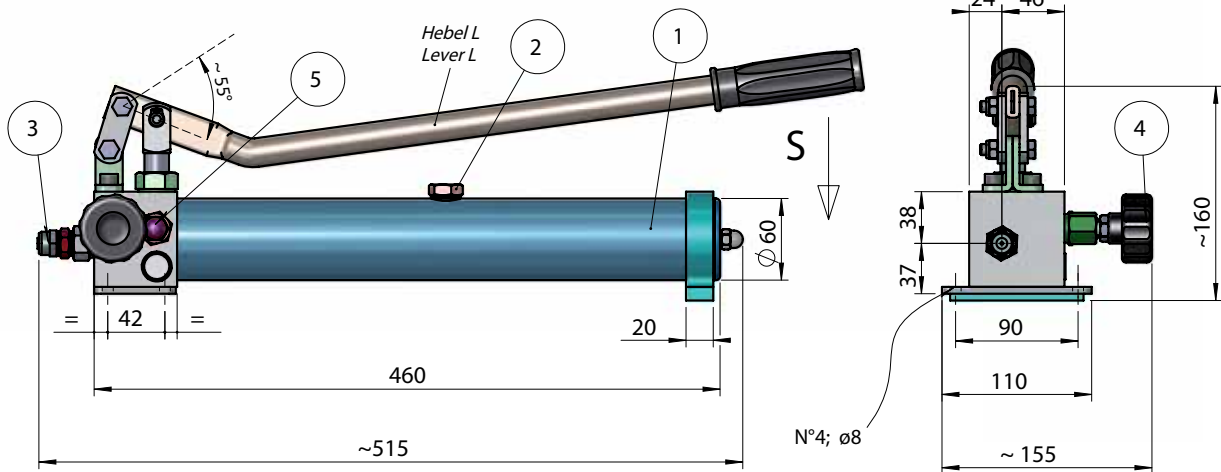

Gewicht - Weight ~4,7 [kg]

- 1 Tank 0,7 l
- 2 Öl-Einfüllstopfen - Filler Plug
- 3 Druckanschluss 1/4" Gas bsp. - Pressure Port 1/4" Gas bsp.
- 4 Ablasshandrad - Release Handknob
- 5 Druckbegrenzungsventil - Relief valve

\* Ventile gehärtet und geschliffen - Hardened and polished valves

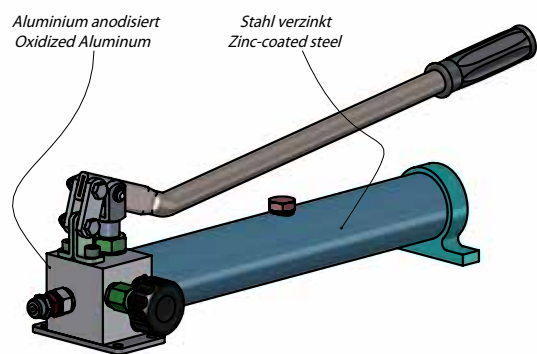
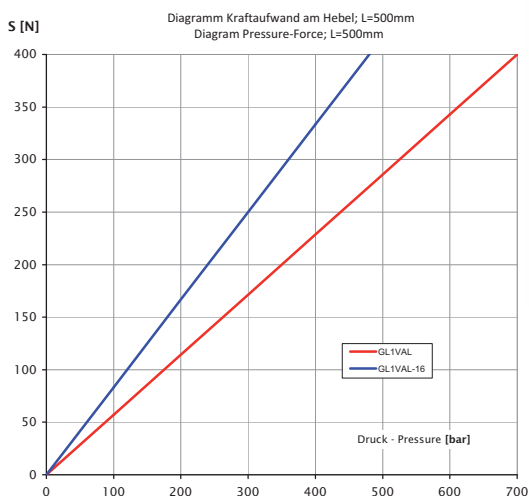
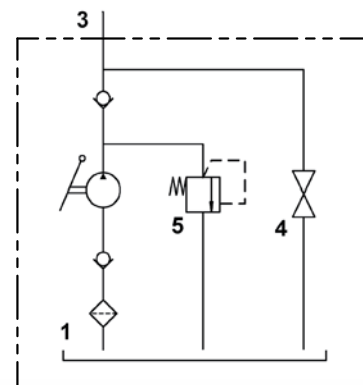
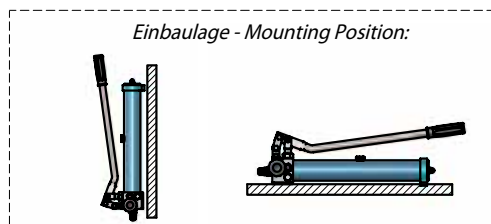

TYP TYPE	A	Fördervolumen Displacement [cm <sup>3</sup> ]	Druck Pressure [bar]
GL1VAL	12	2,8	700
GL1VAL-16	16	4,6	300

Unverbindliche Angaben. Änderungen vorbehalten. - Dimensions not binding. Modifications reserved without prior notice.  
Property of HANSA-TMP SRL. Copying without authorisation will be persecuted by Law.  
Eigentum von HANSA-TMP SRL. Nicht genehmigtes Kopieren wird strafrechtlich verfolgt.

### Pumpe Typ GL12DAL - Pump Type GL12DAL

Einfach-Hubfunktion für einfachwirkende Zylinder  
Single Acting function for single acting cylinder

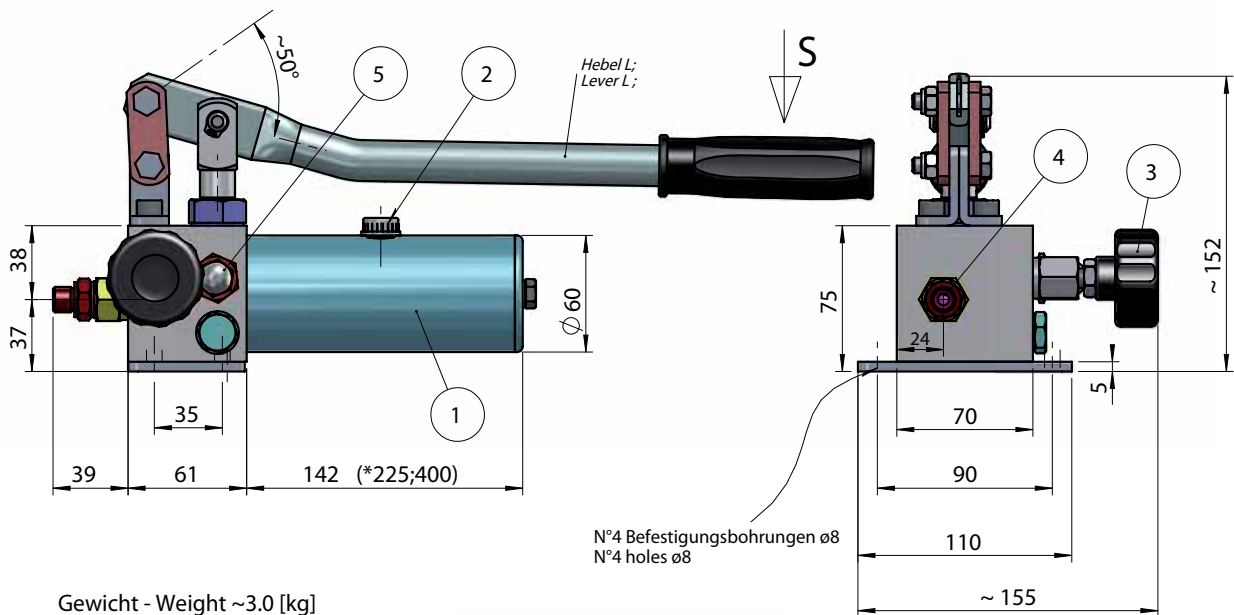

Gewicht - Weight ~3.0 [kg]

- 1 Tank 0,2 l \*
- 2 Öl-Einfüllstopfen (mit Entlüftung) - Filler Plug (with breather)
- 3 Ablasshandrad - Release Handknob
- 4 Druckanschluss 1/4" Gas bsp. - Pressure Port 1/4" Gas bsp.
- 5 Druckbegrenzungsventil - Relief Valve

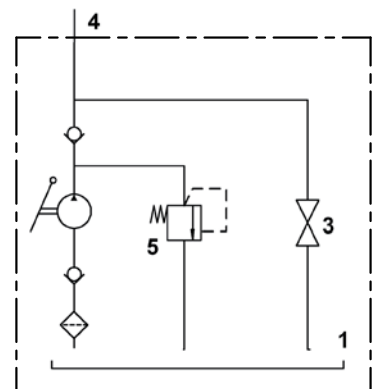
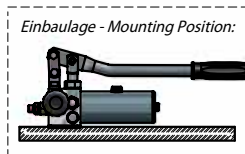

\* Lieferbar auch mit Tanks zu 0,4 bzw. 0,7 l  
\* Available also with 0,4 l and 0,7 l tank

Innenliegende Ventile gehärtet und geschliffen  
Internal valves, hardened and polished

Aluminium AVIONAL anodisiert  
Oxidized Avional Aluminum

Stahl verzinkt  
Zinc-coated Steel

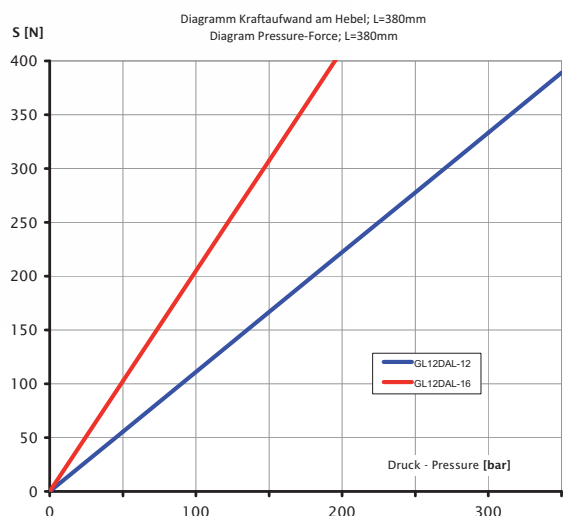
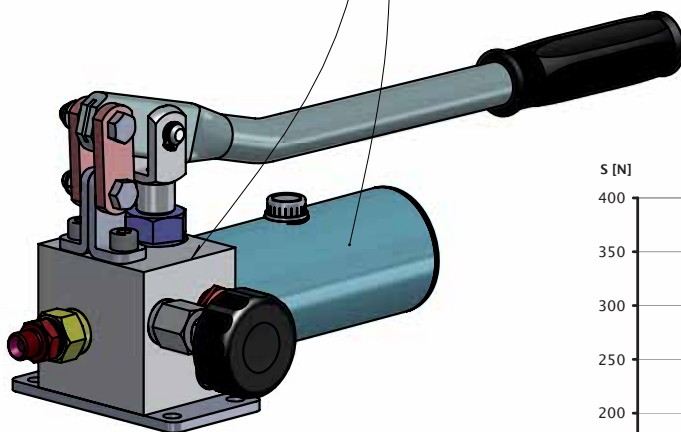

TYP TYPE	Fördervolumen Displacement [cm³]	Druck Pressure [bar]
GL12DAL-12	2,8	370
GL12DAL-16	4,8	200

Unverbindliche Angaben. Änderungen vorbehalten. - Dimensions not binding. Modifications reserved without prior notice.  
Property of HANSA-TMP SRL. Copying without authorisation will be persecuted by Law.  
Eigentum von HANSA-TMP SRL. Nicht genehmigtes Kopieren wird strafrechtlich verfolgt.

### Pumpe Typ GL12-1MAL - Pump Type GL12-1MAL

Einfach-Hubfunktion für einfachwirkende Zylinder  
Single acting function for single acting cylinder

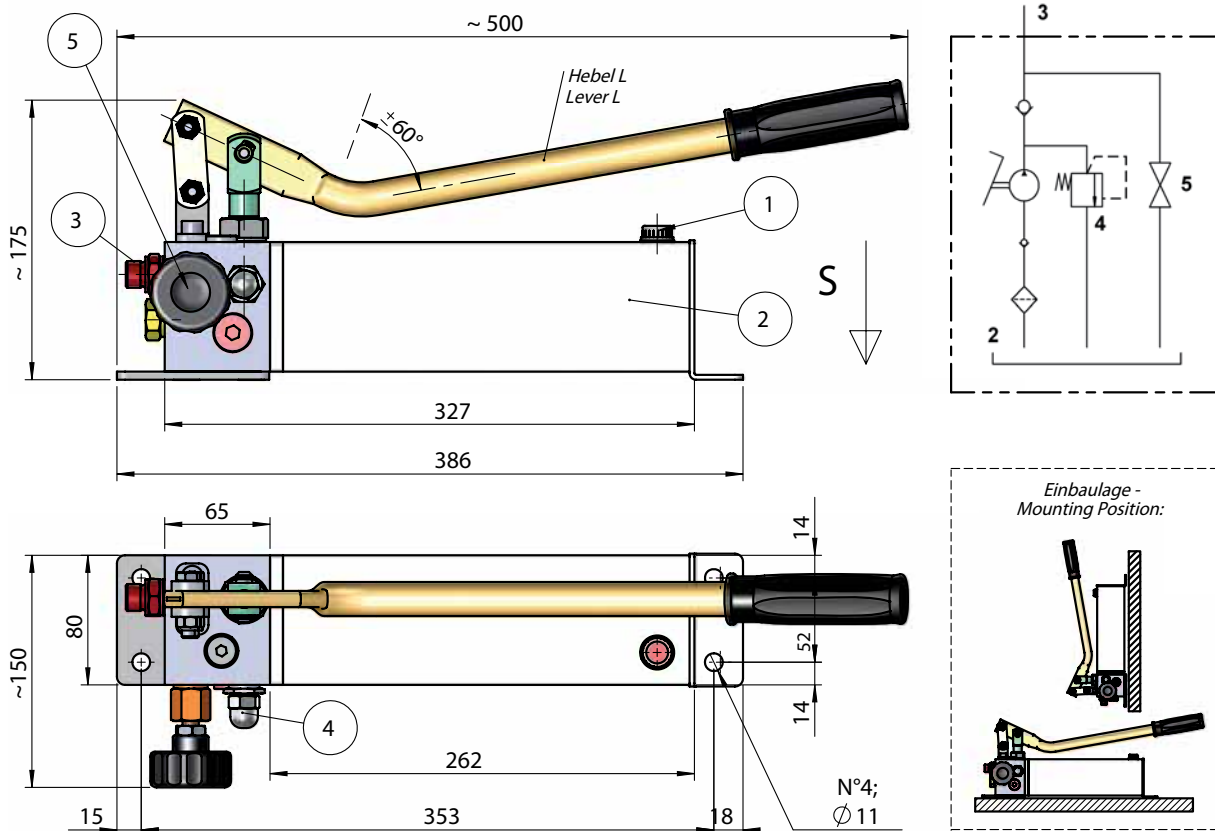

Peso - Weight ~5.5 [kg]

- 1 Öl-Einfüllstopfen - Filler plug
- 2 Tank 1.1 l
- 3 Druckanschluss 3/8" Gas bspp - Pressure port 3/8" Gas bspp
- 4 Druckbegrenzungsventil - Relief Valve
- 5 Ablasshandrad - Release handknob

\*\* Ventile gehärtet und geschliffen - Hardened and polished internal valves

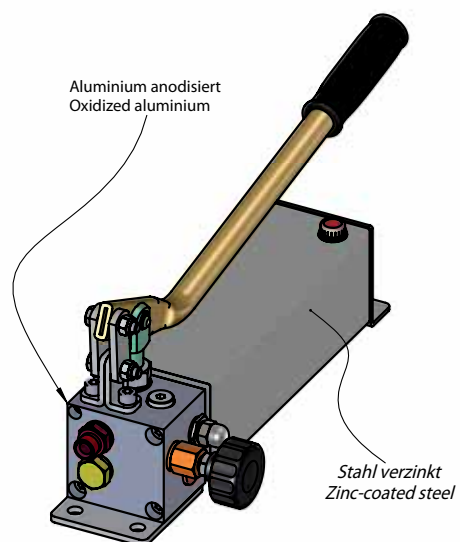
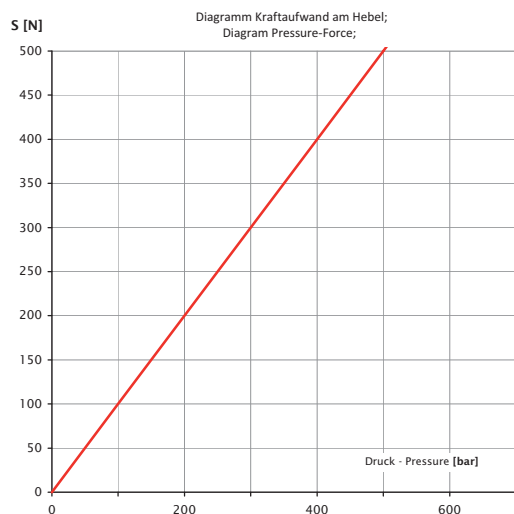

TYP TYPE	Fördervolumen Displacement [cm <sup>3</sup> ]	Druck Pressure [bar]
GL12-1MAL	3,5	370

Unverbindliche Angaben. Änderungen vorbehalten. - Dimensions not binding. Modifications reserved without prior notice.  
Property of HANSA-TMP SRL. Copying without authorisation will be persecuted by Law.  
Eigentum von HANSA-TMP SRL. Nicht genehmigtes Kopieren wird strafrechtlich verfolgt.



### Pumpe Typ GL16Q - Pump Type GL16Q

Einfach-Hubfunktion für einfachwirkende Zylinder  
Single acting function for single acting cylinder

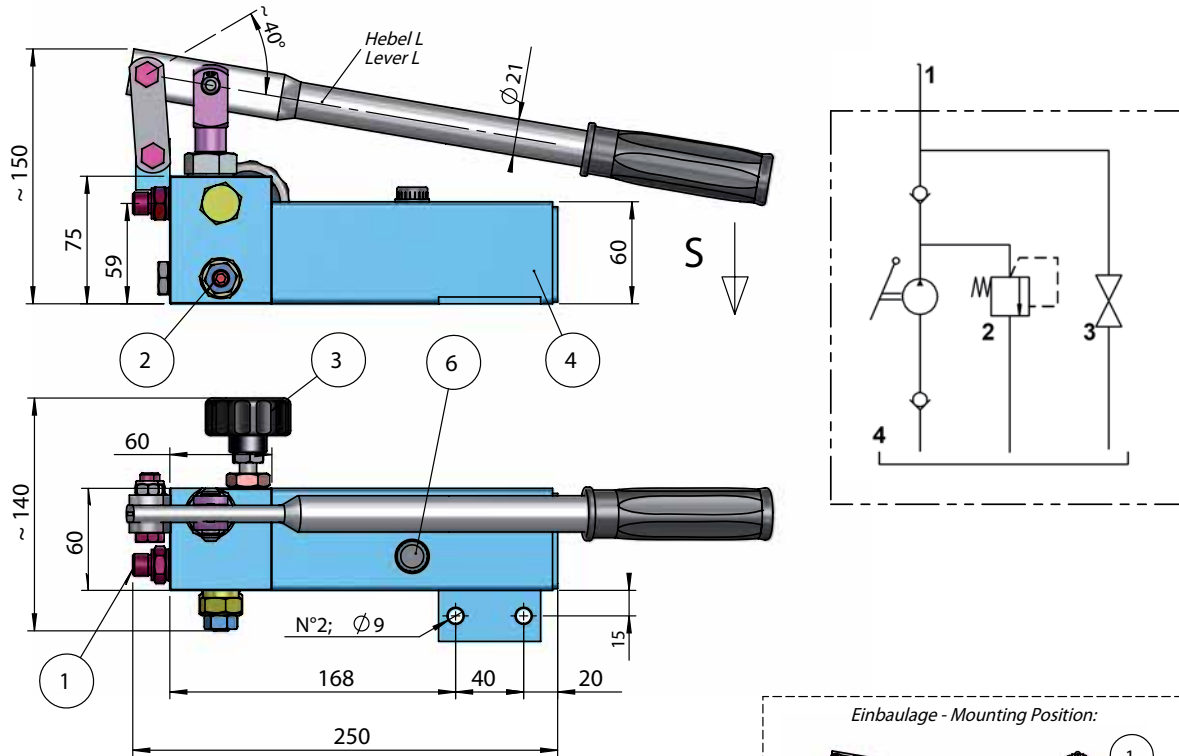

Gewicht - Weight ~4,5 [kg]

- 1 Druckanschluss 1/4" Gas bsp - Pressure Port 1/4" Gas bsp
- 2 Druckbegrenzungsventil - Relief Valve
- 3 Ablasshandrad - Release Handknob
- 4 Tank 0,5 l
- 6 Öl-Einfüllstopfen - Filler plug

\*\*Rückschlagventile gehärtet und geschliffen - Hardened and polished valves

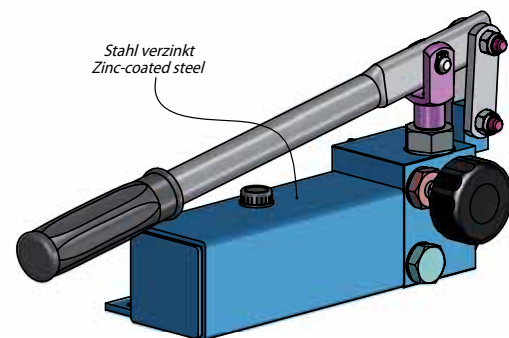
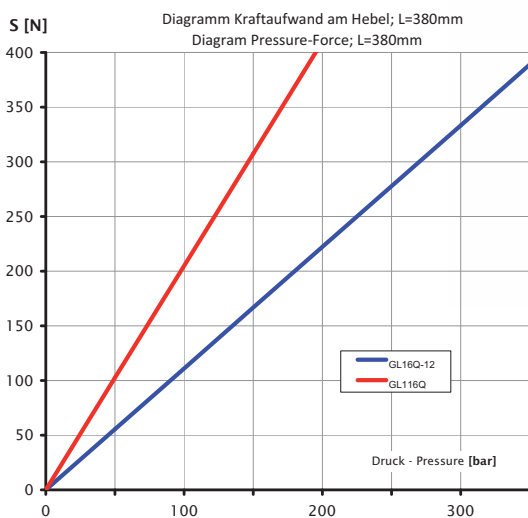

TYP TYPE	Fördervolumen Displacement [cm <sup>3</sup> ]	Druck Pressure [bar]
GL16Q-12	2,8	370
GL16Q	4,8	200

Unverbindliche Angaben. Änderungen vorbehalten. - Dimensions not binding. Modifications reserved without prior notice.  
Property of HANSA-TMP SRL. Copying without authorisation will be persecuted by Law.  
Eigentum von HANSA-TMP SRL. Nicht genehmigtes Kopieren wird strafrechtlich verfolgt.

### Pumpe Typ GL146-ALN - Pump Type GL146-ALN

*Einfach-Hub mit Umschaltventil für doppelwirkenden Zylinder*  
*Single-Acting function with flow diverter for double-acting cylinder*

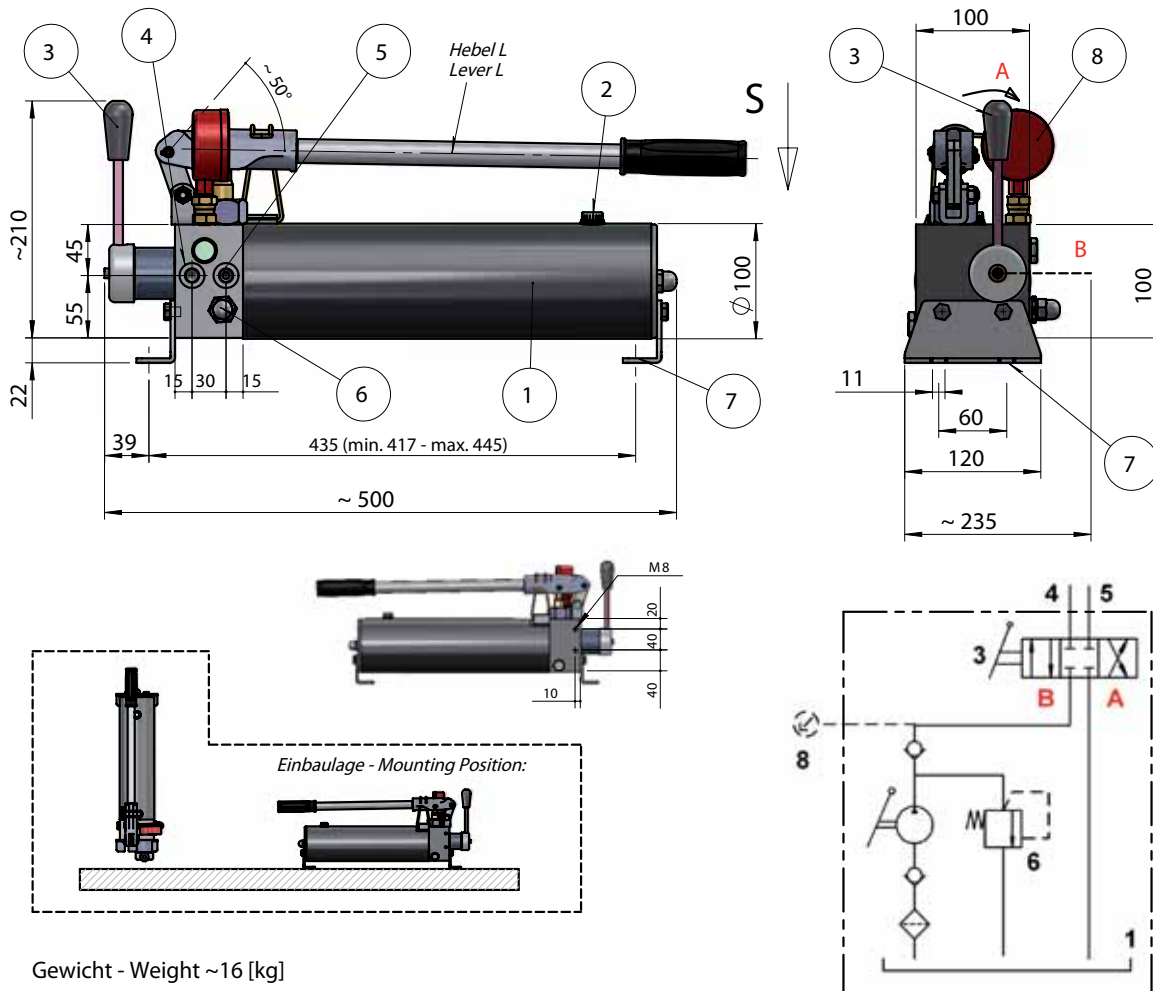

Gewicht - Weight ~16 [kg]

- 1 Tank ~2,1 l
- 2 Öl-Einfüllstopfen - Filler Plug
- 3 Hebel Umschaltventil - Diverter Valve
- 4 Druckanschluss 1 - Pressure Port 1 (1/4" Gas bspp)
- 5 Druckanschluss 2 - Pressure Port 2 (1/4" Gas bspp)
- 6 Druckbegrenzungsventil - Relief Valve
- 7 Befestigungsbohrungen - Mounting Holes
- 8 Manometer (auf Anfrage) - Pressure Gauge (on request)

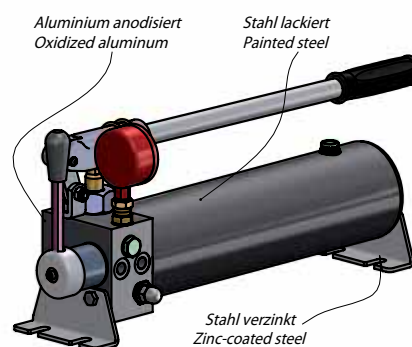
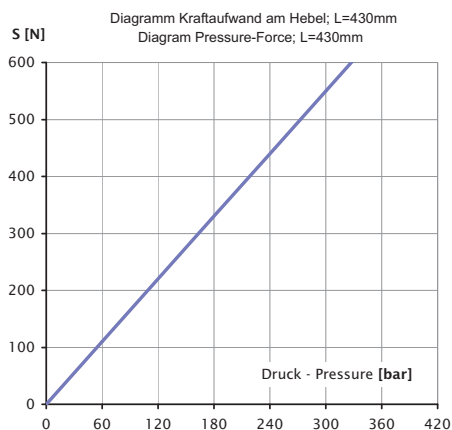

TYP TYPE	Fördervolumen Displacement [cm <sup>3</sup> ]	Druck Pressure [bar]
GL146-ALN	12,5	150

*Unverbindliche Angaben. Änderungen vorbehalten. - Dimensions not binding. Modifications reserved without prior notice.*  
*Property of HANSA-TMP SRL. Copying without authorisation will be persecuted by Law.*  
*Eigentum von HANSA-TMP SRL. Nicht genehmigtes Kopieren wird strafrechtlich verfolgt.*

### Pumpe Typ GL146-ALN-SC - Pump Type GL146-ALN-SC

*Einfach-Hub mit Ablassventil für einfachwirkenden Zylinder*  
*Single-Acting function with release hanknob for single-acting function cylinder*

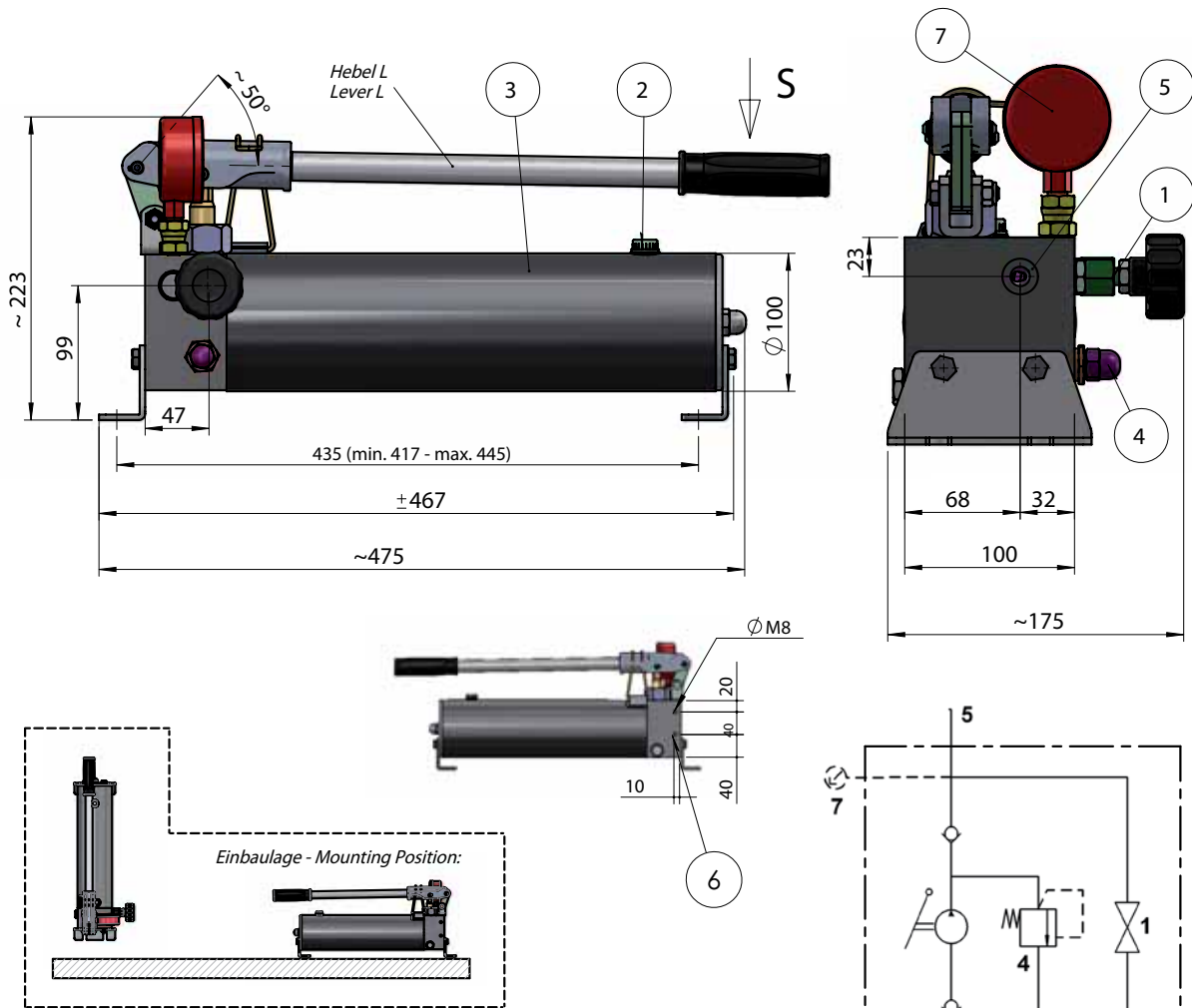

Gewicht - Weight ~10 [kg]

- 1 Ablasshandrad - Release Hanknob
- 2 Öl-Einfüllstopfen - Filler Plug
- 3 Tank 2.1 l
- 4 Druckbegrenzungsventil - Relief Valve
- 5 Druckanschluss - Pressure Port (1/4" Gas bsp)
- 6 Befestigungsbohrungen - Mounting Holes
- 7 Manometer (auf Anfrage) - Pressure Gauge (on request)

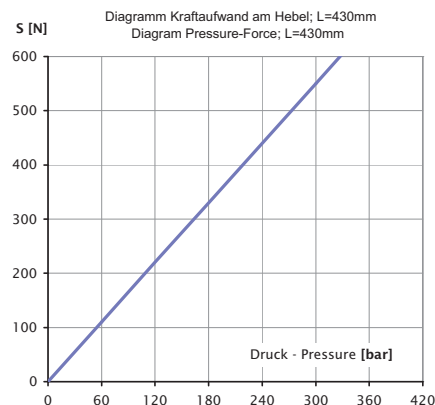

Aluminium  
anodisiert  
Oxidized  
aluminum

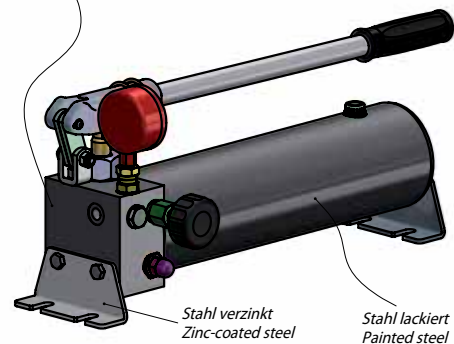

TYP TYPE	Fördervolumen Displacement [cm³]	Druck Pressure [bar]
GL146-ALN	12,5	150

*Unverbindliche Angaben. Änderungen vorbehalten. - Dimensions not binding. Modifications reserved without prior notice.*  
*Property of HANSA-TMP SRL. Copying without authorisation will be persecuted by Law.*  
*Eigentum von HANSA-TMP SRL. Nicht genehmigtes Kopieren wird strafrechtlich verfolgt.*

### Pumpe Typ GL226 - Pump Type GL226

Einfach-Hub für einfachwirkenden Zylinder, Ablassventil normal offen  
Single acting function for single acting cylinder with normally open release valve

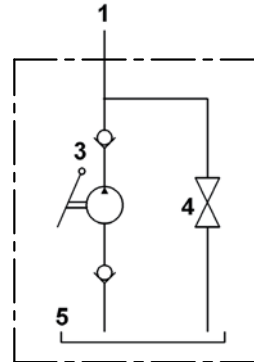
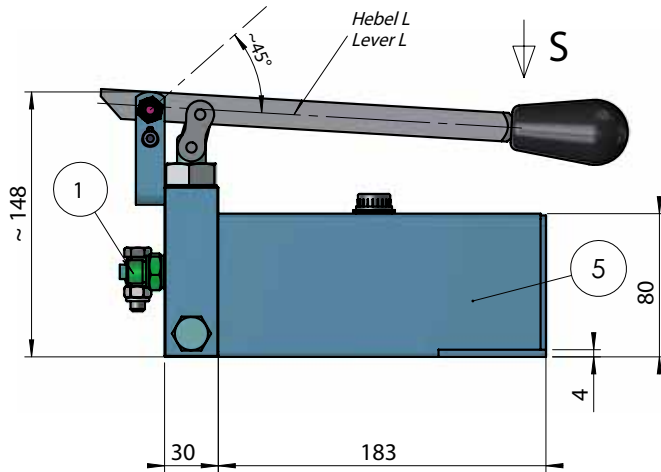

Gewicht - Weight ~ 4,5 [kg]

- 1 Druckanschluss - Pressure Port
- 2 Öl-Einfüllstopfen - Filler Plug
- 3 Pumphebel - Action Lever
- 4 Hebel Ablassventil\* - Release Lever\*
- 5 Tank 1 l

\* Ablassventil normal offen; mit Kraftaufwand F1 betätigen, um Druck zu erzeugen;  
\* Release normally open; please apply F1 force to pressurize the system

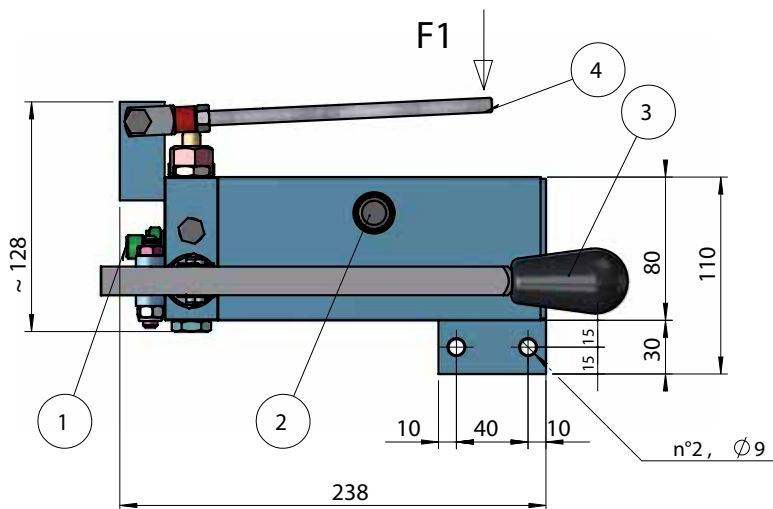

Einbaulage - Mounting Position:

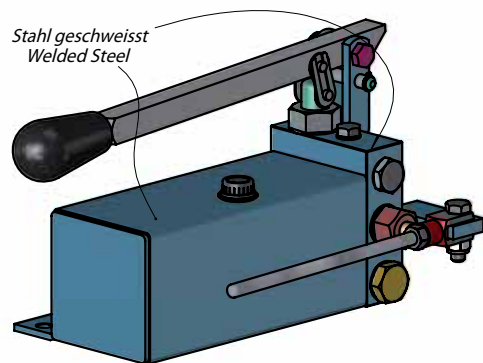
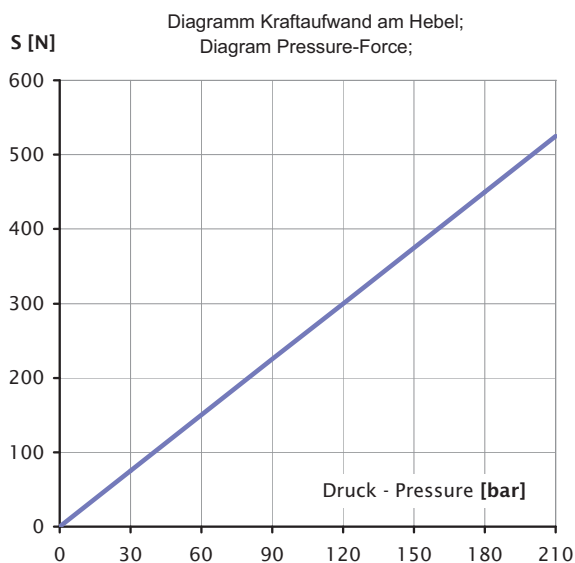
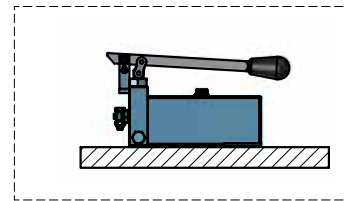

TYP TYPE	Fördervolumen Displacement [cm <sup>3</sup> ]	Druck Pressure [bar]
GL226	5	200

Unverbindliche Angaben. Änderungen vorbehalten. - Dimensions not binding. Modifications reserved without prior notice.  
Property of HANSA-TMP SRL. Copying without authorisation will be persecuted by Law.  
Eigentum von HANSA-TMP SRL. Nicht genehmigtes Kopieren wird strafrechtlich verfolgt.

### Pumpe Typ GL105-M2AL - Pump Type GL105-M2AL

Einfach-Hub mit 2 Pumpkolben  
Single-acting function with 2 pistons

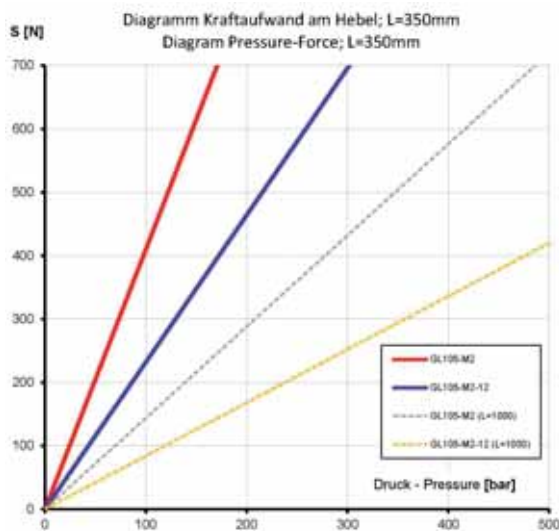
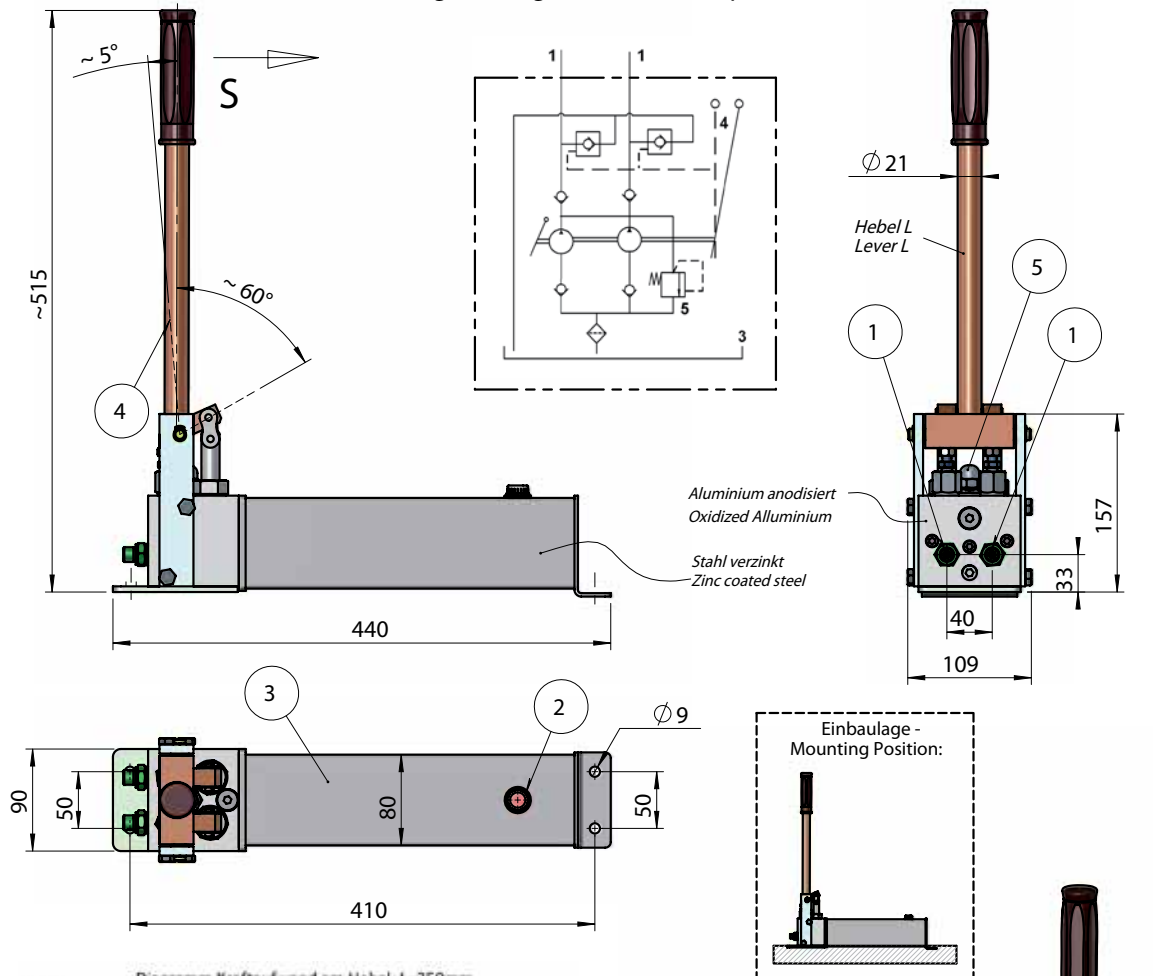

Peso - Weight ~6 [kg]

- 1 Druckanschluss 1/4" Gas bspw (n°2) - Pressure Port 1/4" Gas bspw (n°2)
- 2 Öl-Einfüllstopfen - Filler Plug
- 3 Tank 1,5 l
- 4 Ablasswinkel - Discharge Field
- 5 Druckbegrenzungsventil - Relief Valve

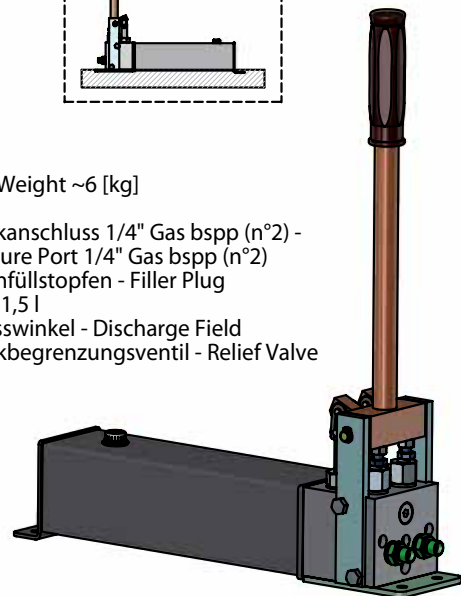

TYP TYPE	A	Fördervolumen Displacement [cm³]	Druck Pressure [bar]
GL105-M2AL	16	10 (5x2)	180
GL105-M2AL-12	12	6,5 (3,2x2)	300

Unverbindliche Angaben. Änderungen vorbehalten. - Dimensions not binding. Modifications reserved without prior notice.  
Property of HANSA-TMP SRL. Copying without authorisation will be persecuted by Law.  
Eigentum von HANSA-TMP SRL. Nicht genehmigtes Kopieren wird strafrechtlich verfolgt.

### Pumpe Typ GL105-M3 - Pump Type GL105-M3

Einfach-Hub mit 3 Pumpkolben  
Single-acting function with 3 pistons

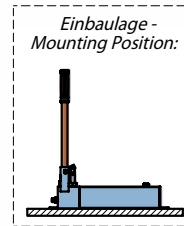
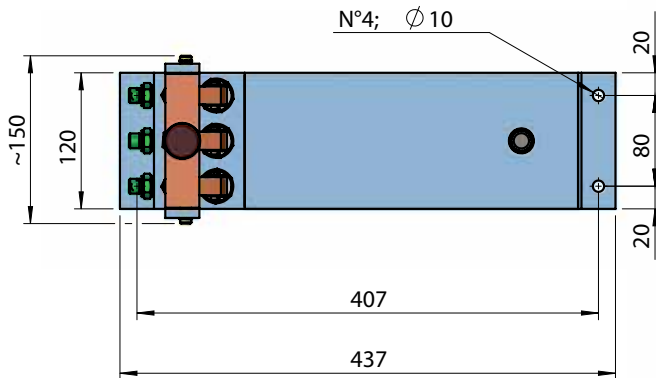
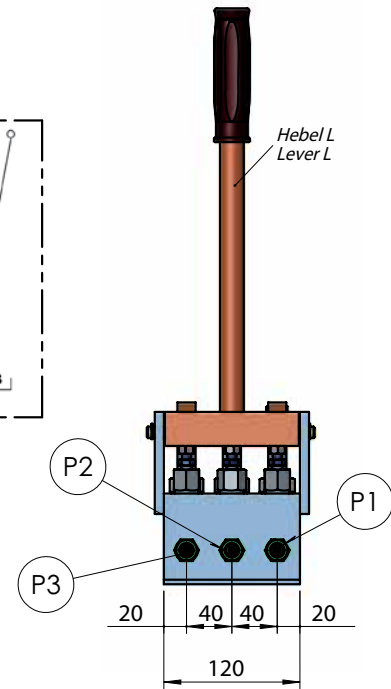
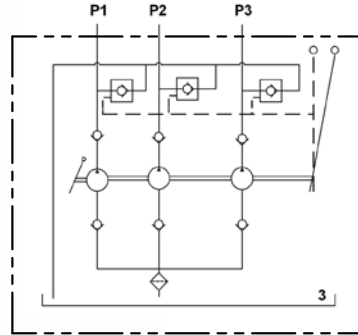
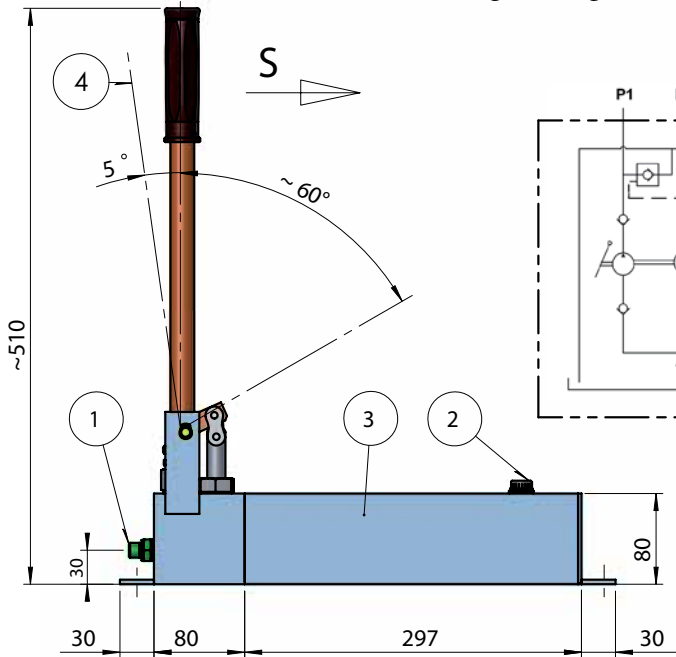

Gewicht - Weight = ~11 [kg]

- 1 Druckanschluss 1/4" Gas bspp (3) - Pressure Port 1/4" Gas bspp (n°3)
- 2 Öl-Einfüllstopfen - Filler Plug
- 3 Tank 2,2 l
- 4 Ablasswinkel - Discharge Field

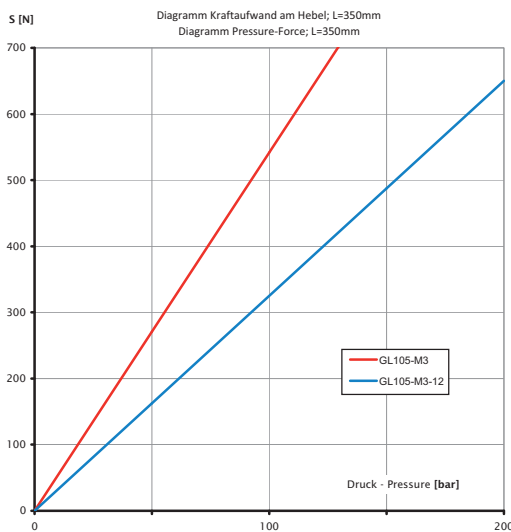

Stahl verzinkt  
Zinc-coated steel

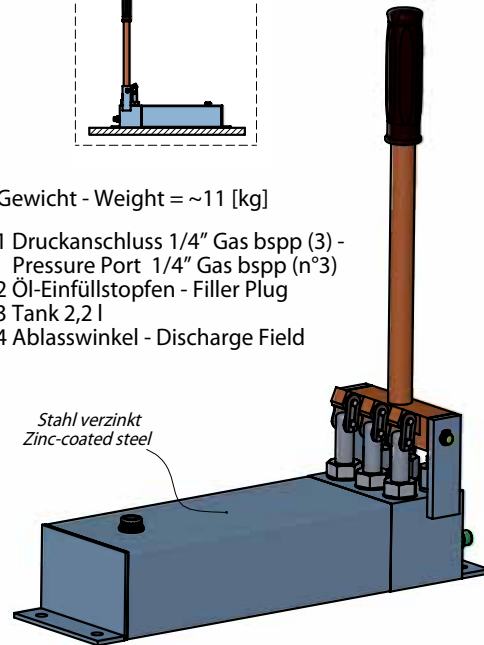

TYP TYPE	A	Fördervolumen Displacement [cm³]	Druck Pressure [bar]
GL105-M3	16	15 (5x3)	120
GL105-M3-12	12	9,6 (3,2x3)	200

Unverbindliche Angaben. Änderungen vorbehalten. - Dimensions not binding. Modifications reserved without prior notice.  
Property of HANSA-TMP SRL. Copying without authorisation will be persecuted by Law.  
Eigentum von HANSA-TMP SRL. Nicht genehmigtes Kopieren wird strafrechtlich verfolgt.

### Pumpe Typ GL105-M4 - Pump Type GL105-M4

Einfach-Hub mit 4 Pumpkolben  
Single-acting function with 4 pistons

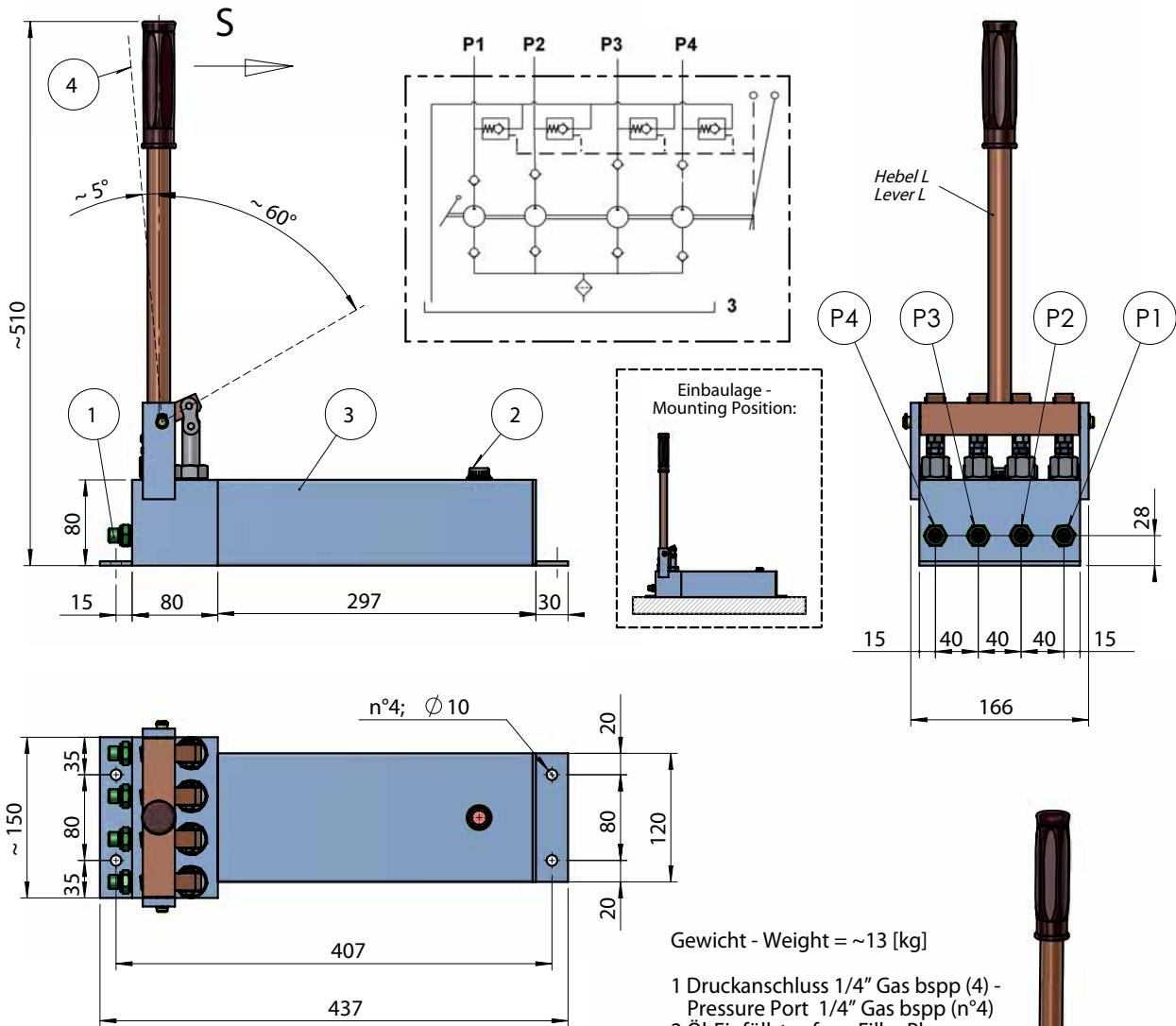

Gewicht - Weight = ~13 [kg]

- 1 Druckanschluss 1/4" Gas bsp (4) - Pressure Port 1/4" Gas bsp (n°4)
- 2 Öl-Einfüllstopfen - Filler Plug
- 3 Tank 2,2 l
- 4 Ablasswinkel - Discharge Field

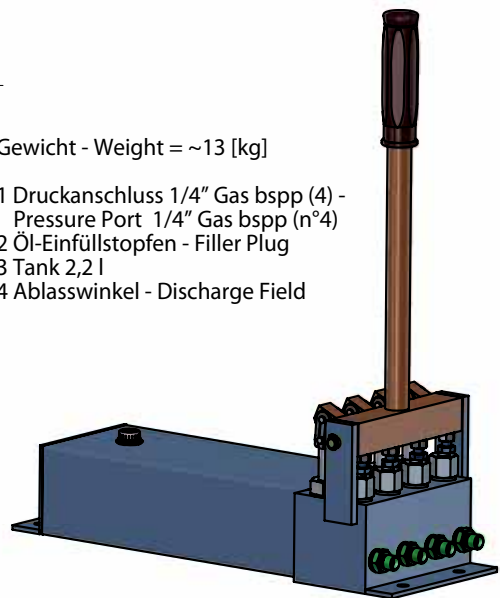
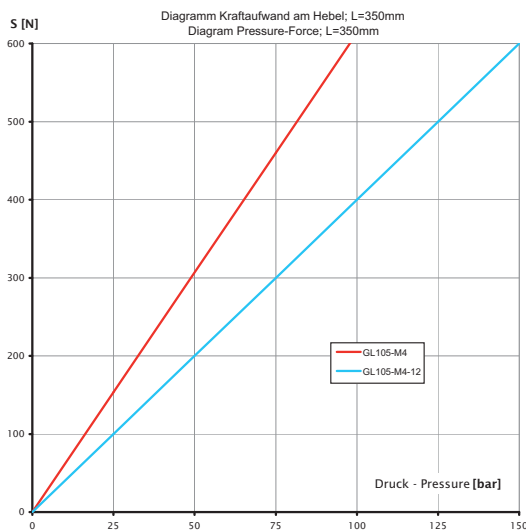

TYP TYPE	A	Fördervolumen Displacement [cm³]	Druck Pressure [bar]
GL105-M4	16	20 (5x4)	80
GL105-M4-12	12	12 (3x4)	150

Unverbindliche Angaben. Änderungen vorbehalten. - Dimensions not binding. Modifications reserved without prior notice.  
Property of HANSA-TMP SRL. Copying without authorisation will be persecuted by Law.  
Eigentum von HANSA-TMP SRL. Nicht genehmigtes Kopieren wird strafrechtlich verfolgt.

### Pumpe Typ GL2P-RV<sub>xx</sub>AL - Pump Type GL2P-RV<sub>xx</sub>AL

2-Stufen-Pumpe, Einfachhub für einfachwirkenden Zylinder  
2 Speed, Single acting function for single acting cylinder

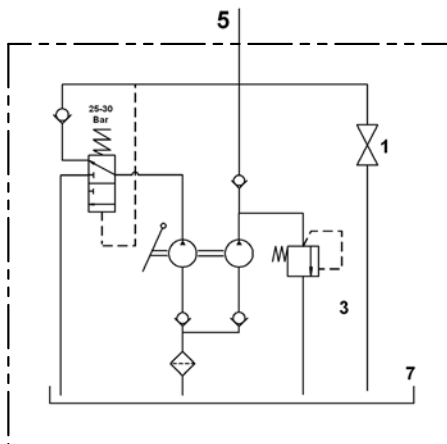
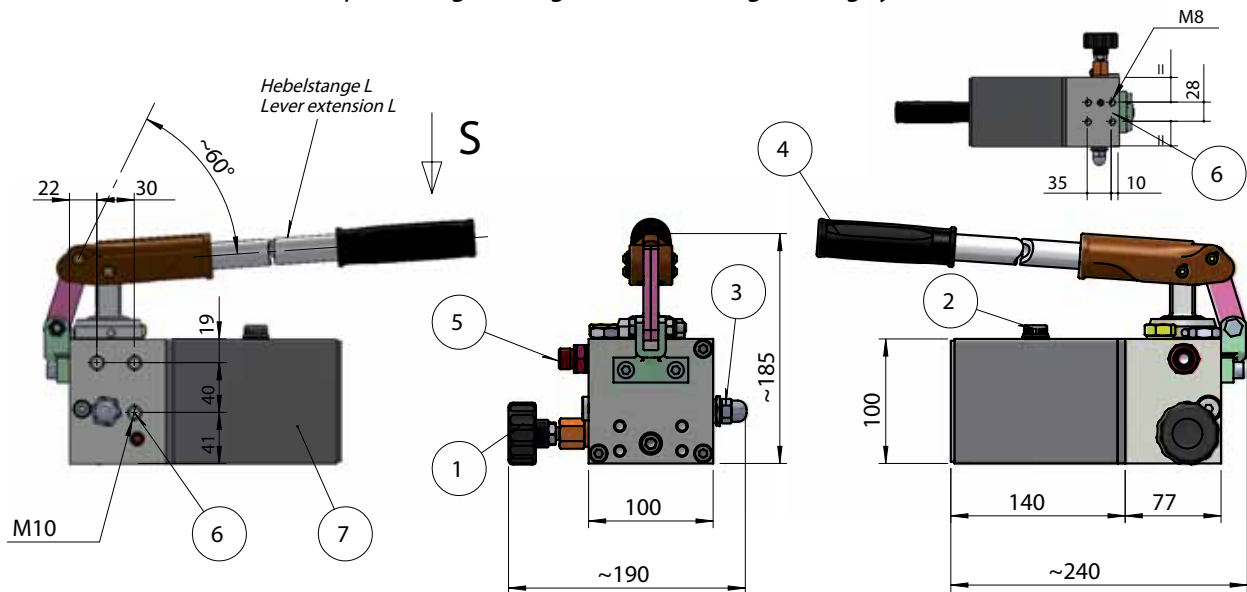

Einbaulage - Mounting position:

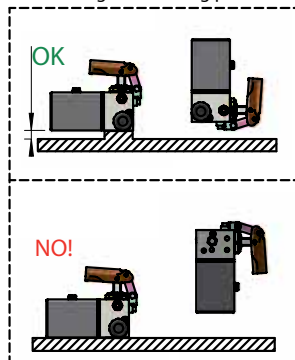

Gewicht - Weight ~ = kg 5.5

- 1 Ablasshandrad - Release Handknob
- 2 Öl-Einfüllstopfen - Filler Plug
- 3 Max-Druckeinstellung - Relief Pressure Setting
- 4 Pumpehebel - Lever
- 5 Druckanschluss 3/8" Gas bspw - Pressure Port 3/8" Gas bspw
- 6 Befestigungsbohrungen - Fixing holes
- 7 Tank 1,2 l

\* Ventile gehärtet und geschliffen  
\* Hardened and polished internal valves

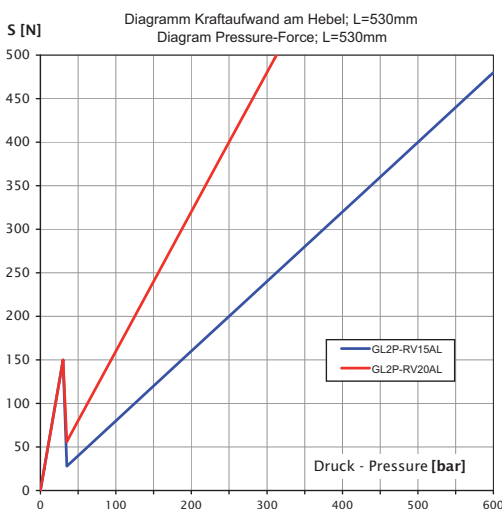

Aluminium AVIONAL anodisiert  
Oxidized aluminium (avional)

Stahl lackiert  
Painted steel

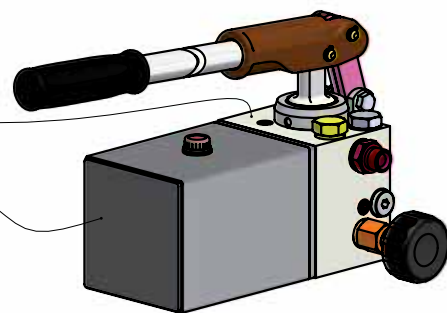

TYP TYPE	Fördervolumen (1° Stufe / 2° Stufe) Displacement (1° speed / 2° speed) [cm <sup>3</sup> ]	Druck (1° Stufe / 2° Stufe) Pressure (1° speed / 2° speed) [bar]
GL2P-RV15AL	24 / 3,8	~25 / 500
GL2P-RV20AL	24 / 8,0	~25 / 250

Unverbindliche Angaben. Änderungen vorbehalten. - Dimensions not binding. Modifications reserved without prior notice.  
Property of HANSA-TMP SRL. Copying without authorisation will be persecuted by Law.  
Eigentum von HANSA-TMP SRL. Nicht genehmigtes Kopieren wird strafrechtlich verfolgt.



### Pumpe Typ GL2P-RV20AL-6LLV - Pump Type GL2P-RV20AL-6LLV

2-Stufen-Pumpe, Einfachhub für einfachwirkenden Zylinder  
2 Speed, Single acting function for single acting cylinder

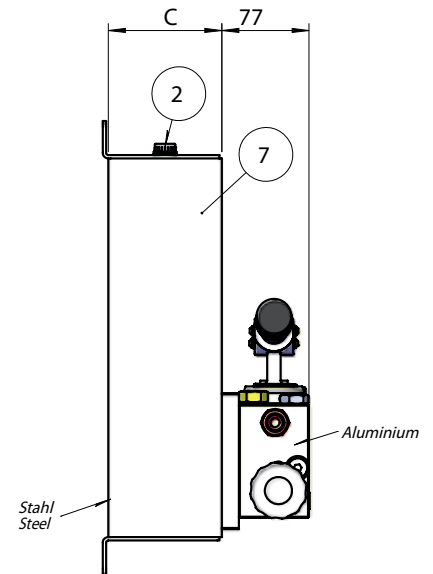
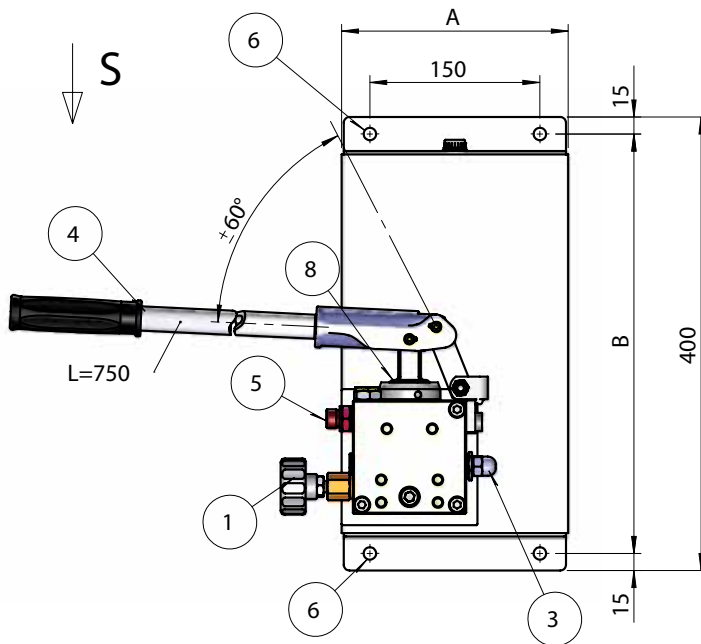

- 1 Ablasshandrad - Release Handknob
- 2 Öl-Einfüllstopfen (TCZS-38-IA-GP) - Filler Plug
- 3 Max-Druckeinstellung - Relief Pressure Setting
- 4 Pumphebel - Lever
- 5 Druckanschluss 3/8" Gas bspp - Pressure Port 3/8" Gas bspp
- 6 Befestigungsbohrungen - Fixing holes
- 7 Tank
- 8 Abstreifer - Scraper

Kode - Code	A	B	C	Tank	Gewicht Weight
GL2P-RV20AL-6LLV	200	370	100	6L	~9Kg

TYP TYPE	Fördervolumen Displacement [cm³]	Druck Pressure [bar]
1° Stufe - Speed	24	~25
2° Stufe - Speed	8	200

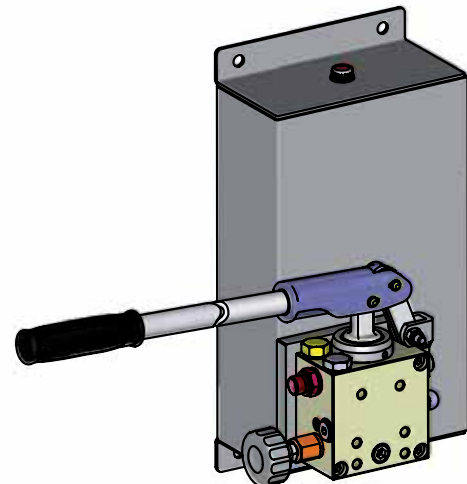
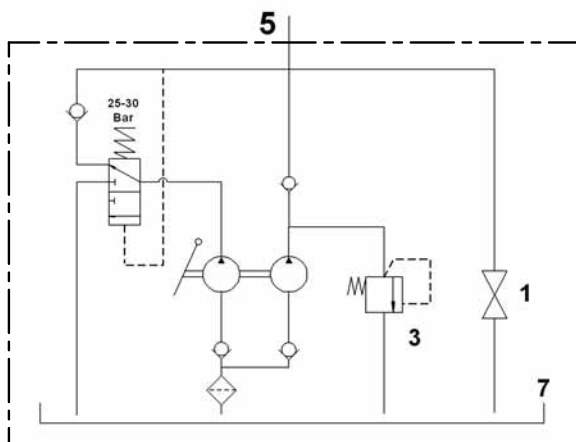
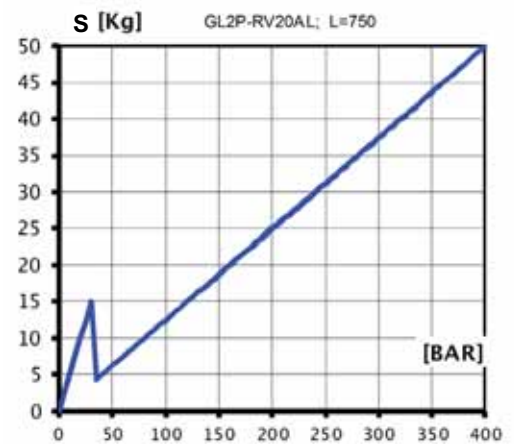

Unverbindliche Angaben. Änderungen vorbehalten. - Dimensions not binding. Modifications reserved without prior notice.  
Property of HANSA-TMP SRL. Copying without authorisation will be persecuted by Law.  
Eigentum von HANSA-TMP SRL. Nicht genehmigtes Kopieren wird strafrechtlich verfolgt.

### Pumpe Typ GL2P-RV20AL-13LLV - Pump Type GL2P-RV20AL-13LLV

2-Stufen-Pumpe, Einfachhub für einfachwirkenden Zylinder  
2 Speed, Single acting function for single acting cylinder

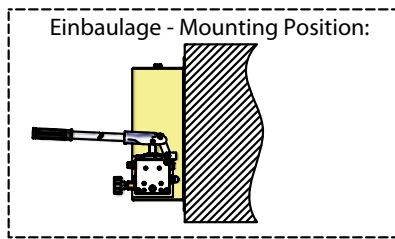
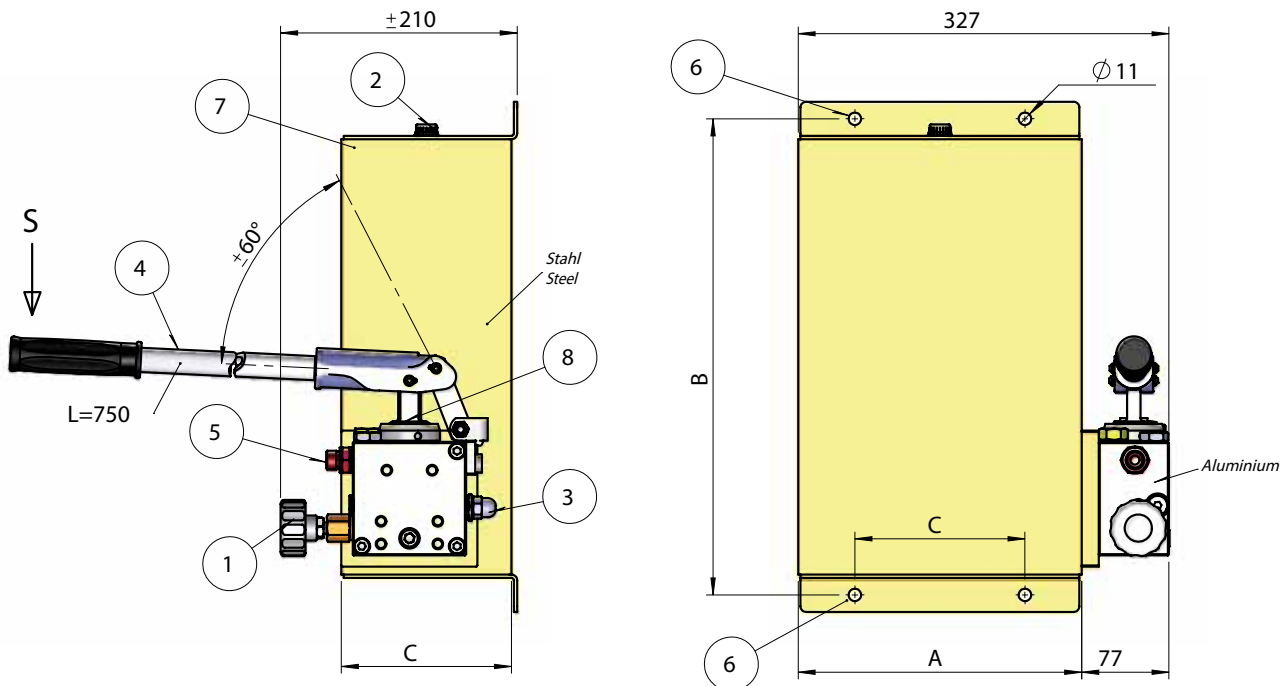

Kode - Code	A	B	C	Tank	Gewicht Weight
GL2P-RV20AL-13LLV	250	420	150	13L	~14Kg

TYP TYPE	Fördervolumen Displacement [cm³]	Druck Pressure [bar]
1° Stufe - Speed	24	~25
2° Stufe - Speed	8	200

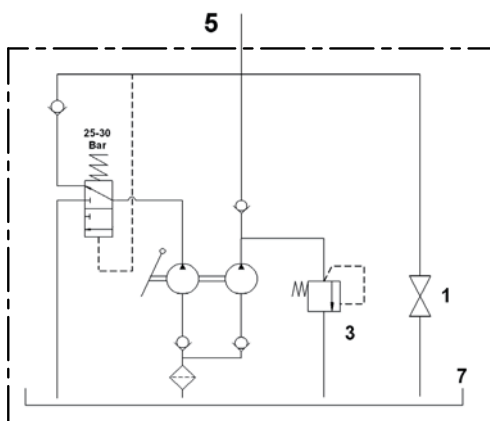
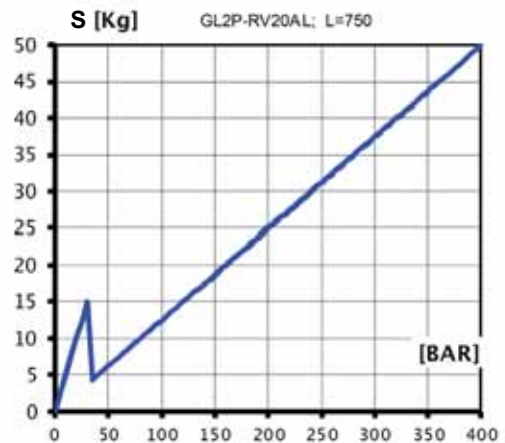

- 1 Ablasshandrad - Release Handknob
- 2 Öl-Einfüllstopfen - Filler Plug
- 3 Max-Druckeinstellung - Relief Pressure Setting
- 4 Pumphebel - Action Lever
- 5 Druckanschluss 3/8" Gas bspp - Pressure Port 3/8" Gas bspp
- 6 Befestigungsbohrungen - Fixing holes
- 7 Tank
- 8 Abstreifer - Scraper

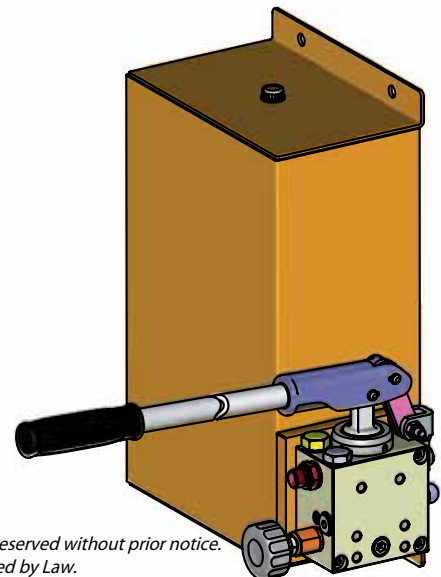

Unverbindliche Angaben. Änderungen vorbehalten. - Dimensions not binding. Modifications reserved without prior notice.  
Property of HANSA-TMP SRL. Copying without authorisation will be persecuted by Law.  
Eigentum von HANSA-TMP SRL. Nicht genehmigtes Kopieren wird strafrechtlich verfolgt.

### Pompa Tipo GL2P-Q - Pump Type GL2P-Q

2-Stufen-Pumpe für einfachwirkende Zylinder  
2 Speed for single acting cylinder

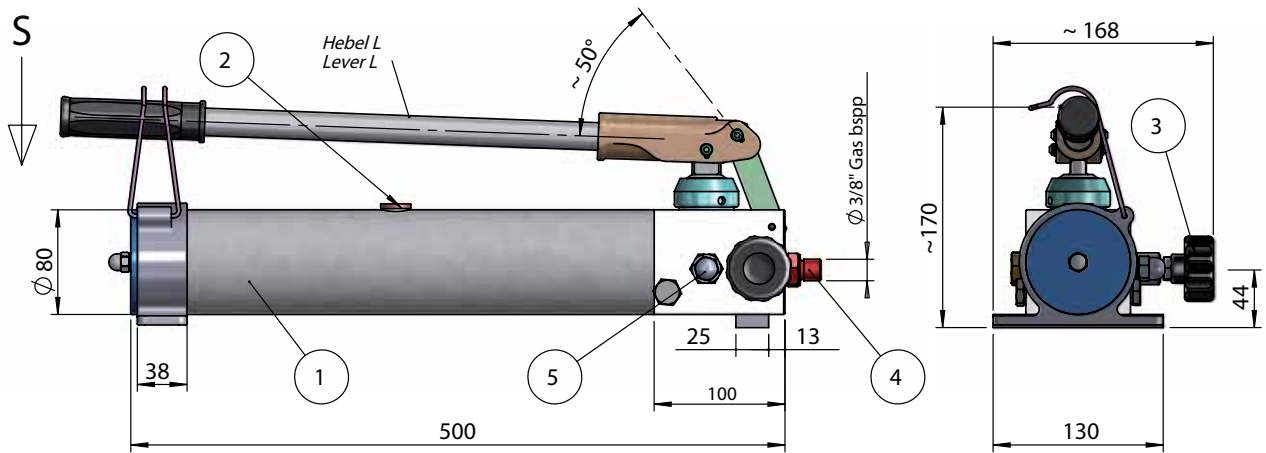

TYP TYPE	Fördervolumen Displacement [cm <sup>3</sup> ]	Druck Pressure [bar]
GL2P-Q 1° Stufe - Speed	17	~25
GL2P-Q 2° Stufe - Speed	2,5	700

Gewicht - Weight ~8 [kg]

- 1 Tank 1,5 l
- 2 Öl-Einfüllstopfen - Filler Plug
- 3 Ablasshandrad - Release Handknob
- 4 Druckanschluss - Pressure Port
- 5 Druckbegrenzungsventil - Relief Valve

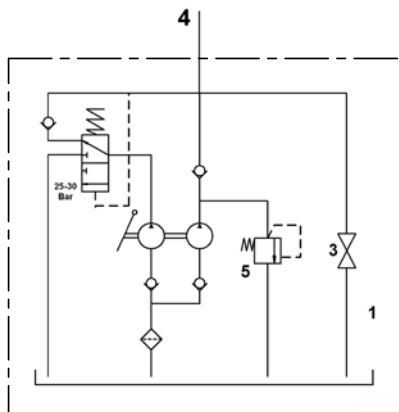

Aluminium AVIONAL anodisiert  
Oxidized avional Aluminum

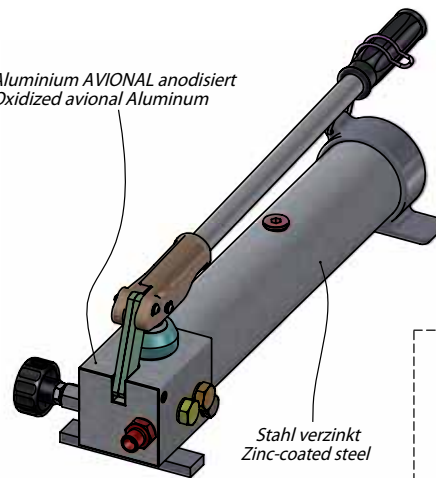

Stahl verzinkt  
Zinc-coated steel

Einbaulage -  
Mounting Position:

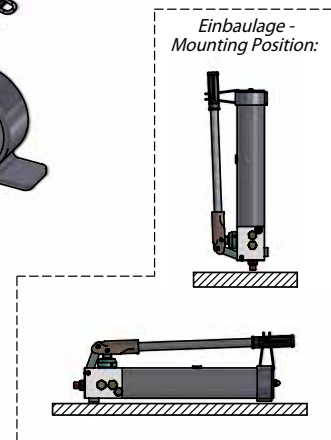

Die Pumpe GL 2P-Q ist besonders geeignet für Einsätze, wo 2 Geschwindigkeiten eines Zylinders gefahren werden sollen.

Die 1. Pumpstufe erlaubt schnelles Ausfahren bei niedrigem Druck, während die 2. Pumpstufe dann mit hohem Druck bei geringem Kraftaufwand arbeitet. Das Umschalten von der 1. auf die 2. Stufe erfolgt automatisch. Diese Pumpe verfügt zudem über absolut dichte Rückschlagventile, hergestellt aus Spezialstahl, gehärtet und geschliffen. Die Dichtheit ist auch bei mehr als 700 Bar gegeben.

The GL 2P-Q, is particularly suitable for applications with need of 2 piston speeds for pumping. The first speed gives fast cylinder advancement while with the second speed the cylinder advancement is very slow but with extremely high pressures, however small pumping forces. The switch-over from first to second speed is automatic. This pump is further equipped with special poppet style valves, made of special treated and hardened steel, which exclude any drain even for pressures up to 700 bar.

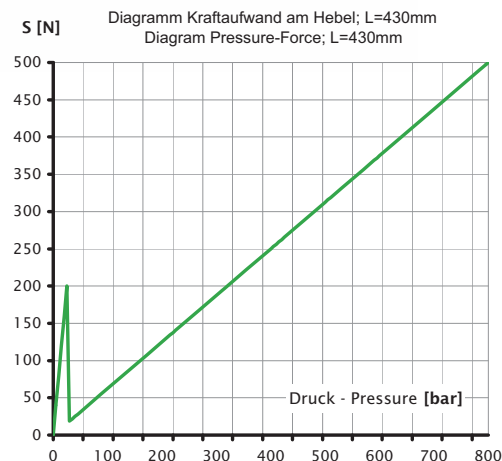

Unverbindliche Angaben. Änderungen vorbehalten. - Dimensions not binding. Modifications reserved without prior notice.  
Property of HANSA-TMP SRL. Copying without authorisation will be persecuted by Law.  
Eigentum von HANSA-TMP SRL. Nicht genehmigtes Kopieren wird strafrechtlich verfolgt.

### Pumpe Typ GL2P-Q 150 - Pump Type GL2P-Q 150

2-Stufen-Pumpe, Einfachhub für einfachwirkenden Zylinder - 2 Speed for single acting cylinder

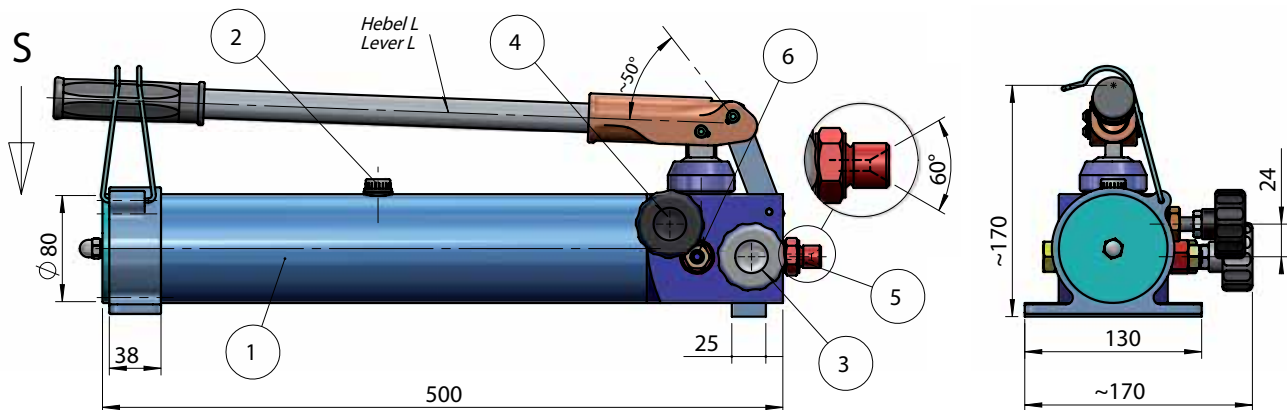

Das Modell GL2P-Q150 ist ähnlich wie das Modell GL2P-Q, jedoch erfolgt das Umschalten nicht automatisch, sondern mittels Handrad. Dieses Modell ermöglicht Drücke bis 1500 Bar mit relativ hohem Fördervolumen.

The GL2P-Q150, is similar to model GL2P-Q but without automatic switch-over of speeds. The switch-over is obtained by a manual handwheel. This is a special pump of remarkable oil-flow for pressures up to 1500 bar.

Gewicht (mit Ölfüllung) - Weight (with oil) ~12 [kg]

- 1 Tank 1,5 l
- 2 Öl-Einfüllstopfen - Filler Plug
- 3 Ablasshandrad - Release Handknob
- 4 Handrad für Abschalten der 1. Pumpstufe -  
1° Speed Exclusion Handknob
- 5 Standard-Druckanschluss 3/8" Gas bspp -  
Standard Pressure Port 3/8" Gas bspp
- 6 Druckbegrenzungsventil - Relief Valve

\* Ventile gehärtet und geschliffen - Hardened and polished valves

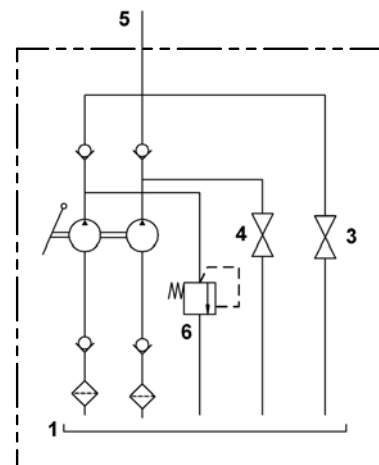

Einbaulage - Mounting Position:

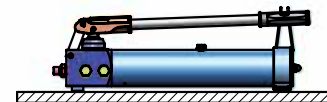

Stahl verzinkt - Zinc-coated steel

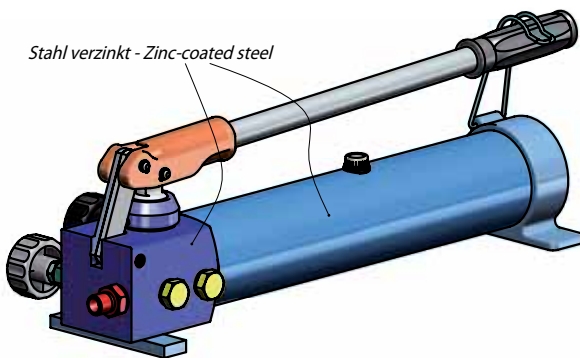

TYP TYPE	Fördervolumen Displacement [cm <sup>3</sup> ]	Druck Pressure [bar]
GL2P-Q150 1° Stufe - Speed	17	100
GL2P-Q150 2° Stufe - Speed	1	1500

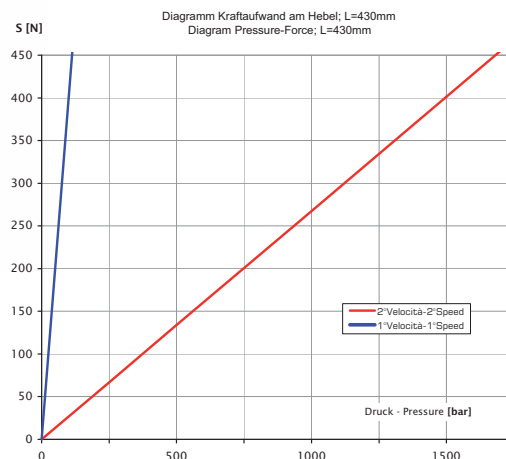

Unverbindliche Angaben. Änderungen vorbehalten. - Dimensions not binding. Modifications reserved without prior notice.  
Property of HANSA-TMP SRL. Copying without authorisation will be persecuted by Law.  
Eigentum von HANSA-TMP SRL. Nicht genehmigtes Kopieren wird strafrechtlich verfolgt.

### Pumpe Typ GL2P-Q+4VN - Pump Type GL2P-Q+4VN

Mit Umschaltventil für doppeltwirkenden Zylinder  
With flow diverter for double-stroke cylinder

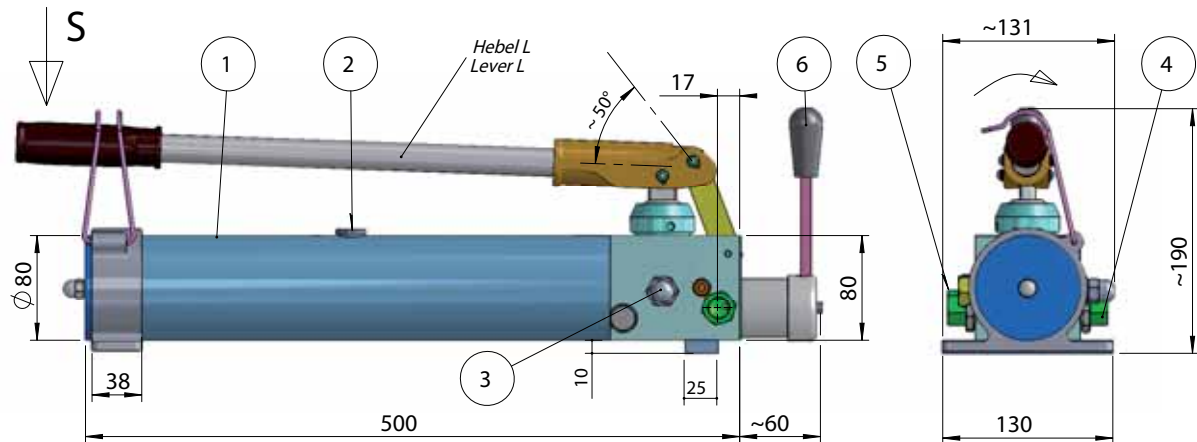

Die Pumpe GL2P-Q+4VN eignet sich besonders für Einsätze, wo zwei Geschwindigkeiten des Zylinders erforderlich sind. Die 1. Pumpenstufe erlaubt schnelles Ausfahren mit niedrigem Druck, die 2. Pumpstufe arbeitet dann mit niedriger Förderleistung bei hohem Druck und geringem Kraftaufwand. Das Umschalten erfolgt automatisch. Die Pumpe verfügt zudem über absolut dichte Ventile aus Spezialstahl, gehärtet und geschliffen; dicht auch bei Druck über 700 Bar.

Einbaulage - Mounting Position:

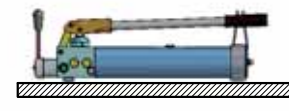

The GL2P-Q+4VN is particularly suitable for applications with need of 2 piston speeds for pumping. The first speed gives fast cylinder advancement while with the second speed the cylinder advancement is very slow but with extremely high pressures, however small pumping forces. The switch-over from first to second speed is automatic. This pump is further equipped with special poppet style valves, made of special treated and hardened steel. Pressures up to 700 bar.

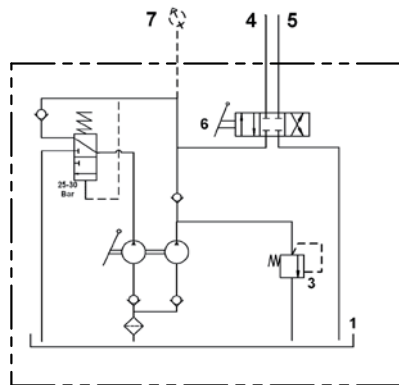

Gewicht - Weight ~9 [kg]

- 1 Tank 1,5 l
- 2 Öl-Einfüllstopfen - Filler Plug
- 3 Druckbegrenzungsventil - Relief Valve
- 4 Druckanschluss 1 (3/8" Gas bspp) - Pressure Port 1 (3/8" Gas bspp)
- 5 Druckanschluss 2 (3/8" Gas bspp) - Pressure Port 2 (3/8" Gas bspp)
- 6 Hebel Umschaltventil - Oil Flow Diverter Lever
- 7 Manometeranschluss (auf Anfrage) - Pressure Gauge Plug (on request)

Aluminium AVIONAL anodisiert  
Avional oxidized Aluminium

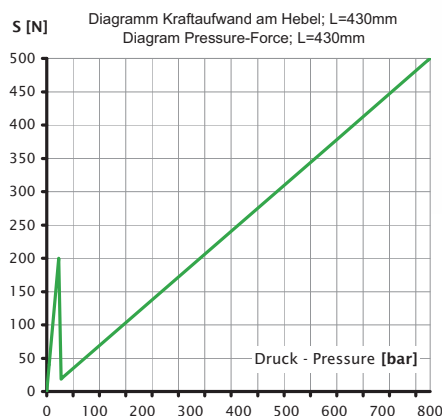
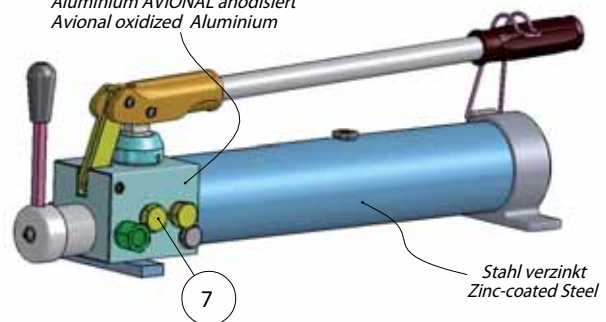

TYP TYPE	Fördervolumen Displacement [cm <sup>3</sup> ]	Druck Pressure [bar]
GL2P-Q+4VN 1° Stufe - Speed	17	~25
GL2P-Q+4VN 2° Stufe - Speed	2,5	700

Unverbindliche Angaben. Änderungen vorbehalten. - Dimensions not binding. Modifications reserved without prior notice.  
Property of HANSA-TMP SRL. Copying without authorisation will be persecuted by Law.  
Eigentum von HANSA-TMP SRL. Nicht genehmigtes Kopieren wird strafrechtlich verfolgt.

### Pumpe Typ GL2P-Q+4VN-VB - Pump Type GL2P-Q+4VN-VB

Mit Umschaltventil für doppelwirkenden Zylinder  
With flow diverter for double acting cylinders

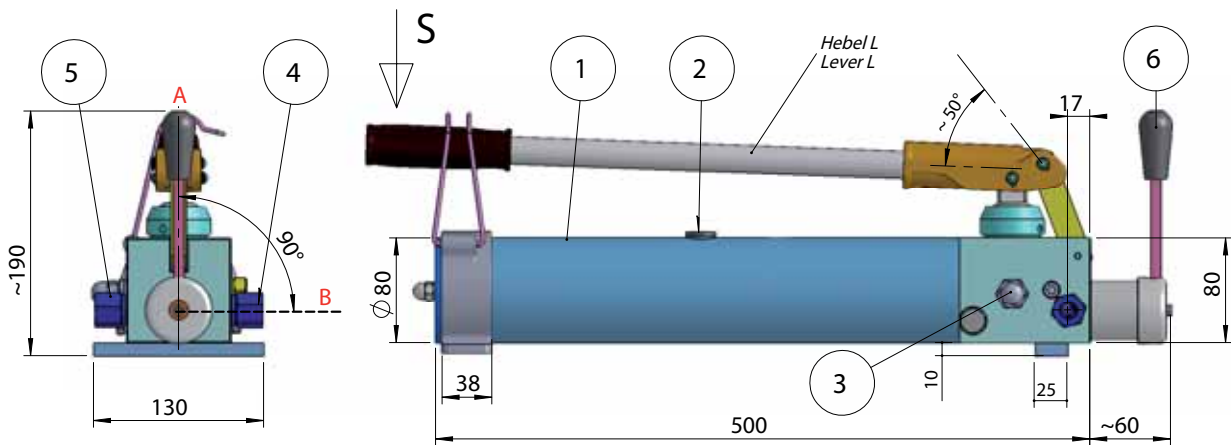

Die Pumpe GL2P-Q+4VN eignet sich besonders für Einsätze, wo zwei Geschwindigkeiten des Zylinders erforderlich sind. Die 1. Pumpenstufe erlaubt schnelles Ausfahren mit niedrigem Druck, die 2. Pumpstufe arbeitet dann mit niedriger Förderleistung bei hohem Druck und geringem Kraftaufwand. Das Umschalten erfolgt automatisch. Die Pumpe verfügt zudem über absolut dichte Ventile aus Spezialstahl, gehärtet und geschliffen; dicht auch bei Druck über 700 Bar.

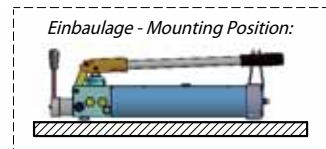

The GL2P-Q+4VN-VB, is particularly suitable for applications with need of 2 piston speeds for pumping. The first speed gives fast cylinder advancement while with the second speed, the cylinder advancement is very slow but with extremely high pressures, however small pumping forces. The switch-over from first to second speed is automatic. This pump is further equipped with special poppet style valves, made of special treated and hardened steel. Pressures up to 700 bar.

Gewicht - Weight ~9 [kg]

- 1 Tank 1,5 l
- 2 Öl-Einfüllstopfen - Filler Plug
- 3 Druckbegrenzungsventil - Relief Valve
- 4 Druckanschluss 1 (3/8" Gas bspp) - Pressure Port 1 (3/8" Gas bspp)
- 5 Druckanschluss 2 (3/8" Gas bspp) - Pressure Port 2 (3/8" Gas bspp)
- 6 Hebel Umschaltventil - Oil Flow Diverter Lever
- 7 Manometeranschluss (auf Anfrage) - Pressure Gauge Plug (on request)
- 8 Vorgesteuerte Rückschlagventile - Pilot Check Valve

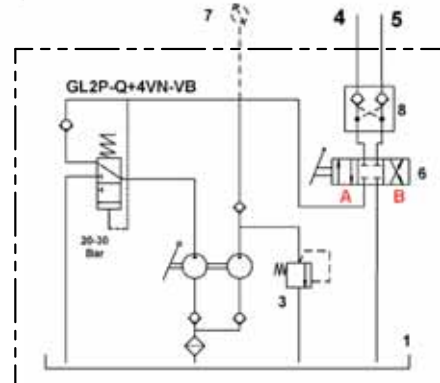
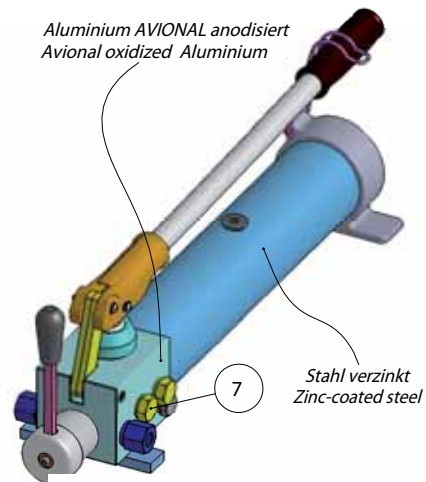
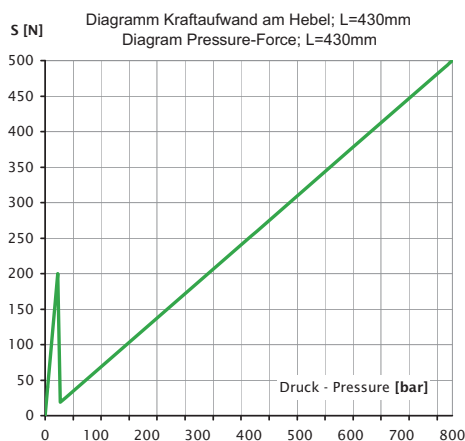

TYP TYPE	Fördervolumen Displacement [cm³]	Druck Pressure [bar]
GL2P-Q+4VN-VB 1° Stufe - Speed	17	~25
GL2P-Q+4VN-VB 2° Stufe - Speed	2,5	700

Unverbindliche Angaben. Änderungen vorbehalten. - Dimensions not binding. Modifications reserved without prior notice.  
Property of HANSA-TMP SRL. Copying without authorisation will be persecuted by Law.  
Eigentum von HANSA-TMP SRL. Nicht genehmigtes Kopieren wird strafrechtlich verfolgt.

### Pumpe Typ GL2P70-A - Pump Type GL2P70-A

2-Stufen-Handpumpe, einfachwirkend  
2 Speed, single acting function

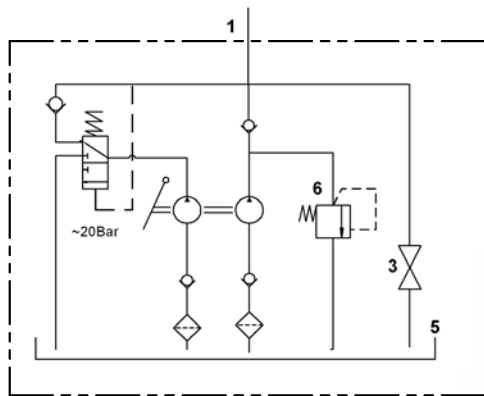
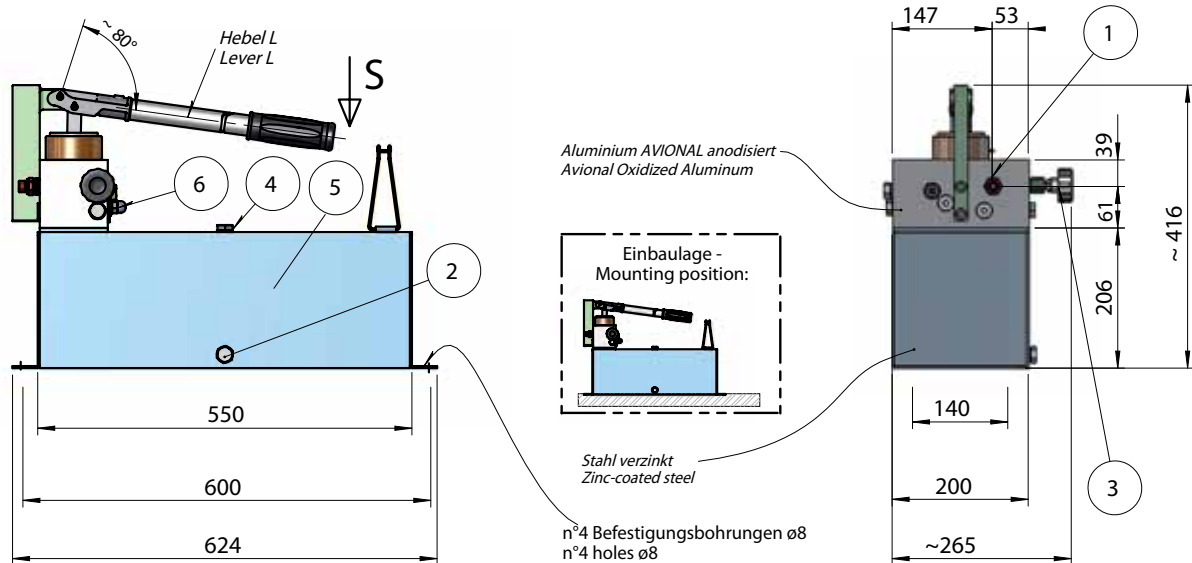

Gewicht - Weight ~22Kg

- 1 Druckanschluss (3/8" Gas bspp) - Pressure Port (3/8" Gas bspp)
- 2 Tank-Ablass-Stopfen - Discharge Plug
- 3 Ablasshandrad - Release Handknob
- 4 Öl-Einfüllstopfen - Filler Plug
- 5 Tank 18 l
- 6 Max-Druckeinstellung - Relief Valve Setting

\* Ventile gehärtet und geschliffen - Hardened and polished valves

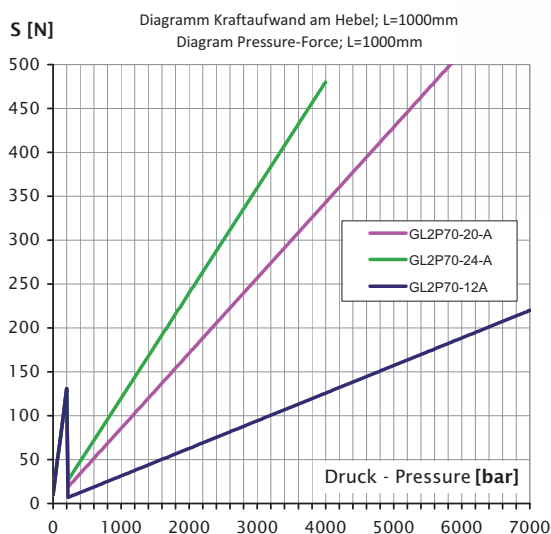
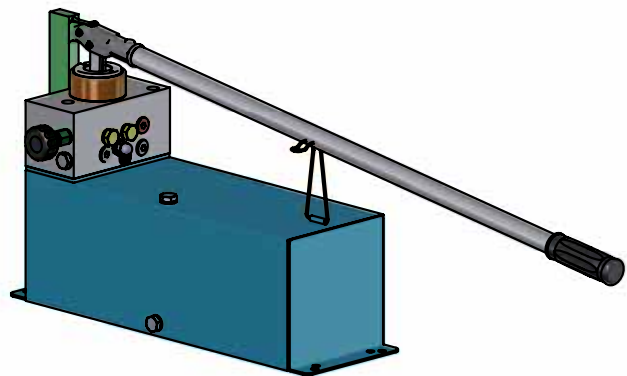

TYP TYPE	Fördervolumen (1° stufe / 2° stufe) Displacement (1° speed / 2° speed) [cm <sup>3</sup> ]	Druck (1° stufe / 2° stufe) Pressure (1° speed / 2° speed) [bar]
GL2P70-12-A	~133 / 4	~20 / 700
GL2P70-20-A	~133 / 12	~20 / 400
GL2P70-24-A	~133 / 18	~20 / 300

Unverbindliche Angaben. Änderungen vorbehalten. - Dimensions not binding. Modifications reserved without prior notice.  
Property of HANSA-TMP SRL. Copying without authorisation will be persecuted by Law.  
Eigentum von HANSA-TMP SRL. Nicht genehmigtes Kopieren wird strafrechtlich verfolgt.

### Pumpe Typ GL2P70-iA - Pump Type GL2P70-iA

Zweistufenpumpe, einfachwirkend, für doppeltwirkenden Zylinder, mit Ablassventil.  
Auf Wunsch zertifiziert ATEX 94/9/CE (II 2 GD c IIB T6 T85°C)  
2 Speed, single acting function, for double acting cylinder with release handknob.  
On request with ATEX 94/9/CE (II 2 GD c IIB T6 T85°C) certification

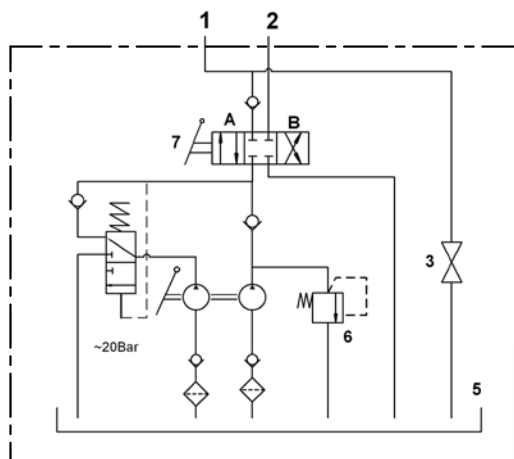
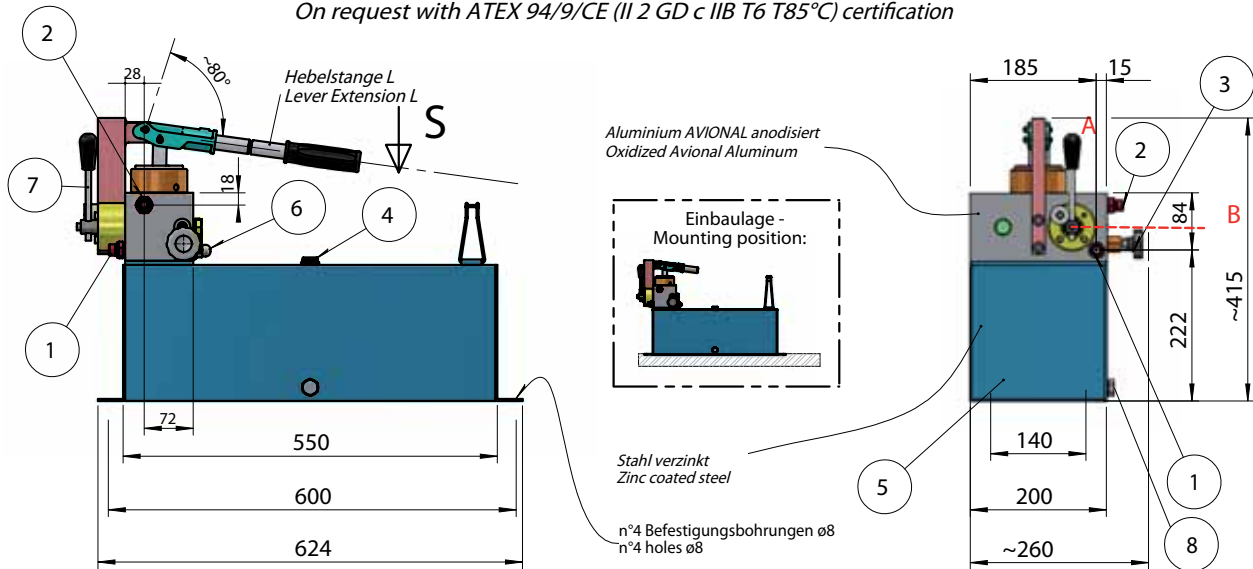

Gewicht - Weight ≈ 22Kg

- 1 Druckanschluss 1 (3/8" Gas bspp) - Pressure Port 1 (3/8" Gas bspp)
- 2 Druckanschluss 2 (3/8" Gas bspp) - Pressure Port 2 (3/8" Gas bspp)
- 3 Ablasshandrad (auf Druckseite 1) - Release Handknob (on pressure port 1)
- 4 Öl-Einfüllstopfen - Filler Plug
- 5 Tank 18 l
- 6 Max-Druckeinstellung - Relief Valve Setting
- 7 Hebel Umschaltventil - Oil Flow Diverter Lever
- 8 Ablass-Stopfen - Tank Discharge Plug

Ventile gehärtet und geschliffen - Hardened and polished valves

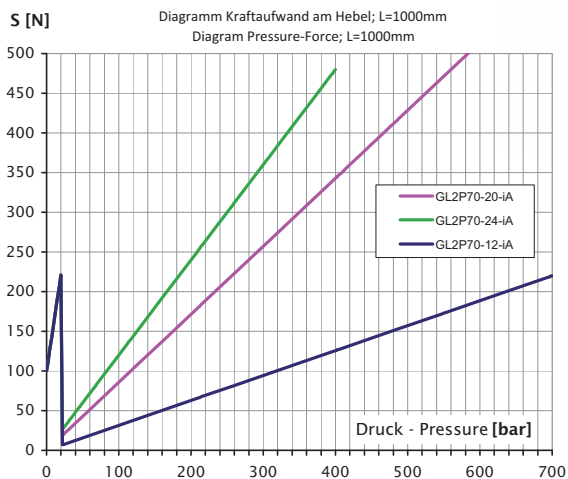
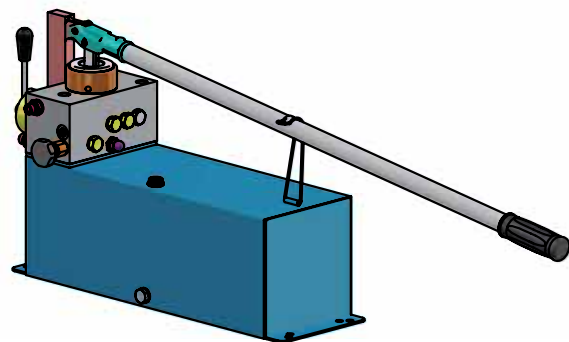

TYP TYPE	Fördervolumen (1° stufe / 2° stufe) Displacement (1° speed / 2° speed) [cm <sup>3</sup> ]	Druck (1° stufe / 2° stufe) Pressure (1° speed / 2° speed) [bar]
GL2P70-12-IA	~133 / 4	~20 / 700
GL2P70-20-IA	~133 / 12	~20 / 400
GL2P70-24-IA	~133 / 18	~20 / 300

Unverbindliche Angaben. Änderungen vorbehalten. - Dimensions not binding. Modifications reserved without prior notice.  
Property of HANSA-TMP SRL. Copying without authorisation will be persecuted by Law.  
Eigentum von HANSA-TMP SRL. Nicht genehmigtes Kopieren wird strafrechtlich verfolgt.



### Pumpe Typ GL2P70-AS - Pump Type GL2P70-AS

2-Stufen-Handpumpe, einfachwirkend - 2 Speed, single acting function

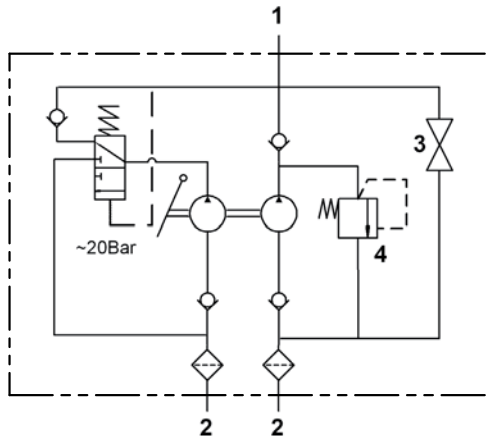
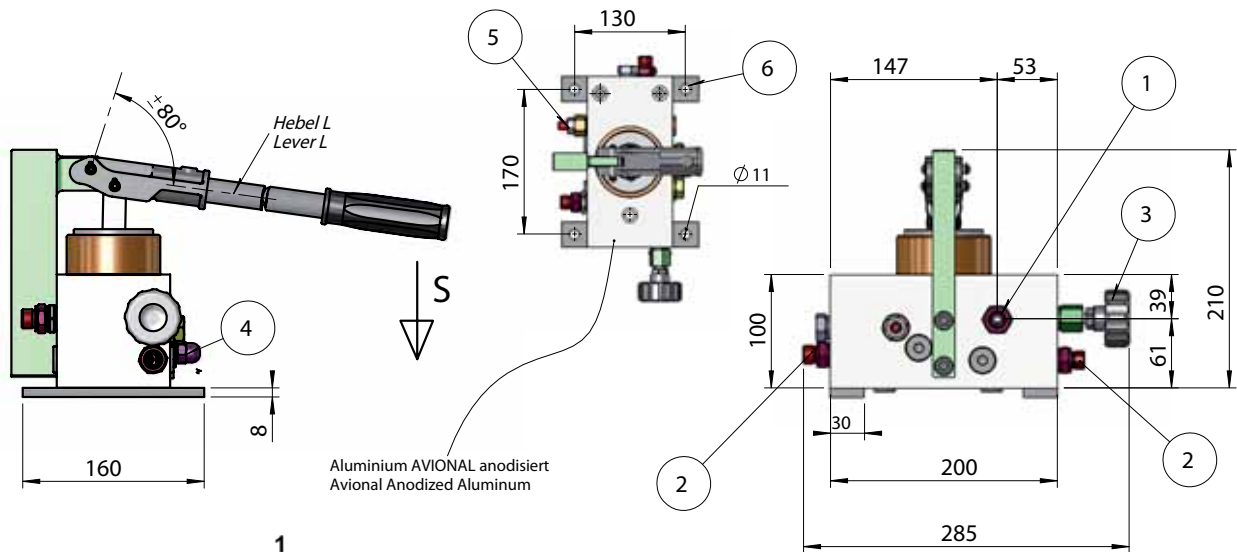

Gewicht - Weight ~11Kg

- 1 Druckanschluss (3/8" gas bspp) - Pressure Port (3/8" gas bspp)
- 2 Sauganschluss (3/8" gas bspp) - Suction Port (3/8" gas bspp)
- 3 Ablasshandrad - Release Handknob
- 4 Max-Druckeinstellung - Relief Valve Setting
- 5 Einstellung Umschaltventil by-pass (10-30 bar) - By-pass Setting (10-30 bar)
- 6 Befestigungsbohrungen - Mounting Holes

Ventile gehärtet und geschliffen - Hardened and polished internal valves

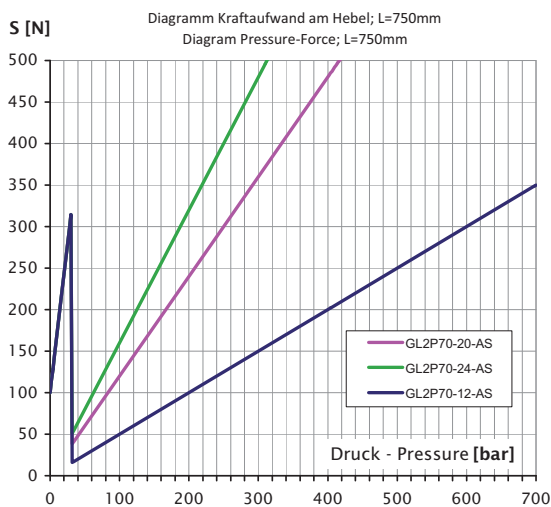
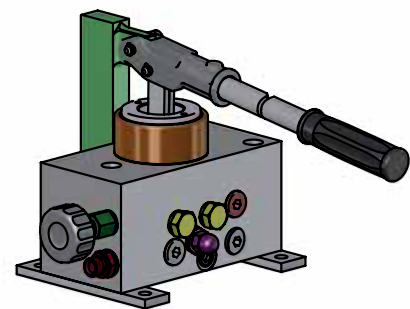
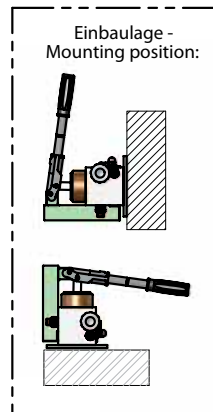

TYP TYPE	Fördervolumen (1° Stufe / 2° Stufe) Displacement (1° speed / 2° speed) [cm³]	Druck (1° Stufe / 2° Stufe) Pressure (1° speed / 2° speed) [bar]
GL2P70-12-AS	~133 / 4	~20 / 700
GL2P70-20-AS	~133 / 12	~20 / 350
GL2P70-24-AS	~133 / 18	~20 / 250

Unverbindliche Angaben. Änderungen vorbehalten. - Dimensions not binding. Modifications reserved without prior notice.  
Property of HANSA-TMP SRL. Copying without authorisation will be persecuted by Law.  
Eigentum von HANSA-TMP SRL. Nicht genehmigtes Kopieren wird strafrechtlich verfolgt.

### Pumpe Typ GL2P70-ASSTHA - Pump Type GL2P70-ASSTHA

2-Stufen-Handpumpe, einfachwirkend - 2 Speed, single acting function

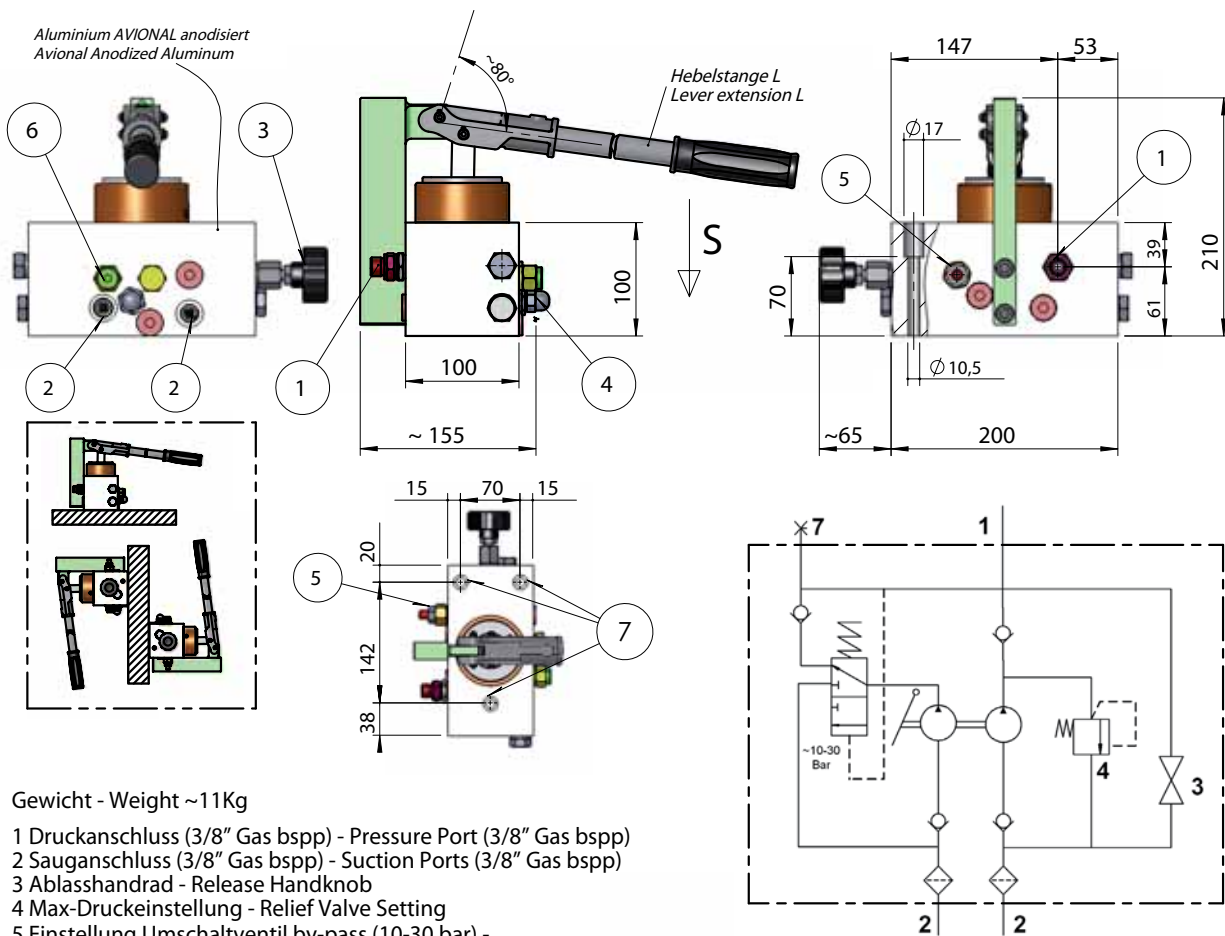

Gewicht - Weight ~11Kg

- 1 Druckanschluss (3/8" Gas bspp) - Pressure Port (3/8" Gas bspp)
- 2 Sauganschluss (3/8" Gas bspp) - Suction Ports (3/8" Gas bspp)
- 3 Ablasshandrad - Release Handknob
- 4 Max-Druckeinstellung - Relief Valve Setting
- 5 Einstellung Umschaltventil by-pass (10-30 bar) - By-pass setting (10-30 bar)
- 6 Manometeranschluss - Pressure Gauge Port
- 7 Befestigungsbohrungen - Mounting Holes

\* Innenliegende Ventile gehärtet und geschliffen - Hardened and polished internal valves

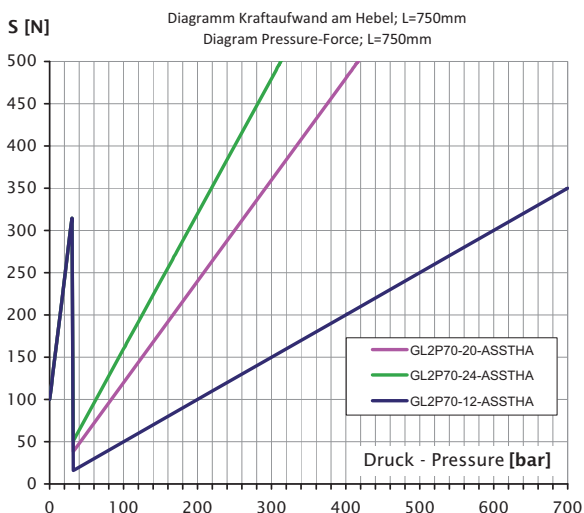
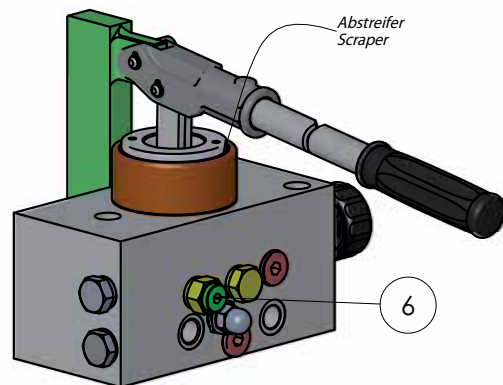
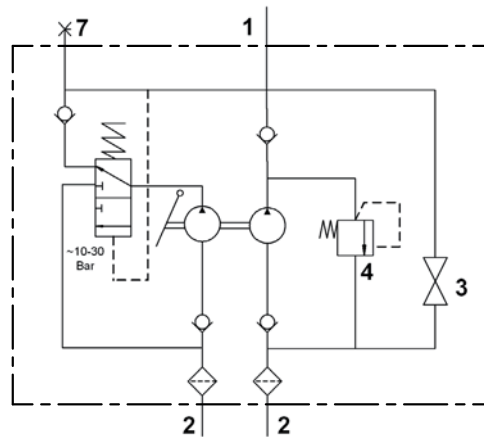

TYP TYPE	Fördervolumen (1° Stufe / 2° Stufe) Displacement (1° speed / 2° speed) [cm³]	Druck (1° Stufe / 2° Stufe) Pressure (1° speed / 2° speed) [bar]
GL2P70-12-ASSTHA	~133 / 4	~(10-30) / 700
GL2P70-20-ASSTHA	~133 / 12	~(10-30) / 350
GL2P70-24-ASSTHA	~133 / 18	~(10-30) / 250

Unverbindliche Angaben. Änderungen vorbehalten. - Dimensions not binding. Modifications reserved without prior notice.  
Property of HANSA-TMP SRL. Copying without authorisation will be persecuted by Law.  
Eigentum von HANSA-TMP SRL. Nicht genehmigtes Kopieren wird strafrechtlich verfolgt.

### Pumpe Typ GL241F3 - Pump Type GL241F3

2-Stufen-Pumpe, Einfachhub für einfachwirkenden Zylinder  
2 Speed, single acting function for single acting cylinder

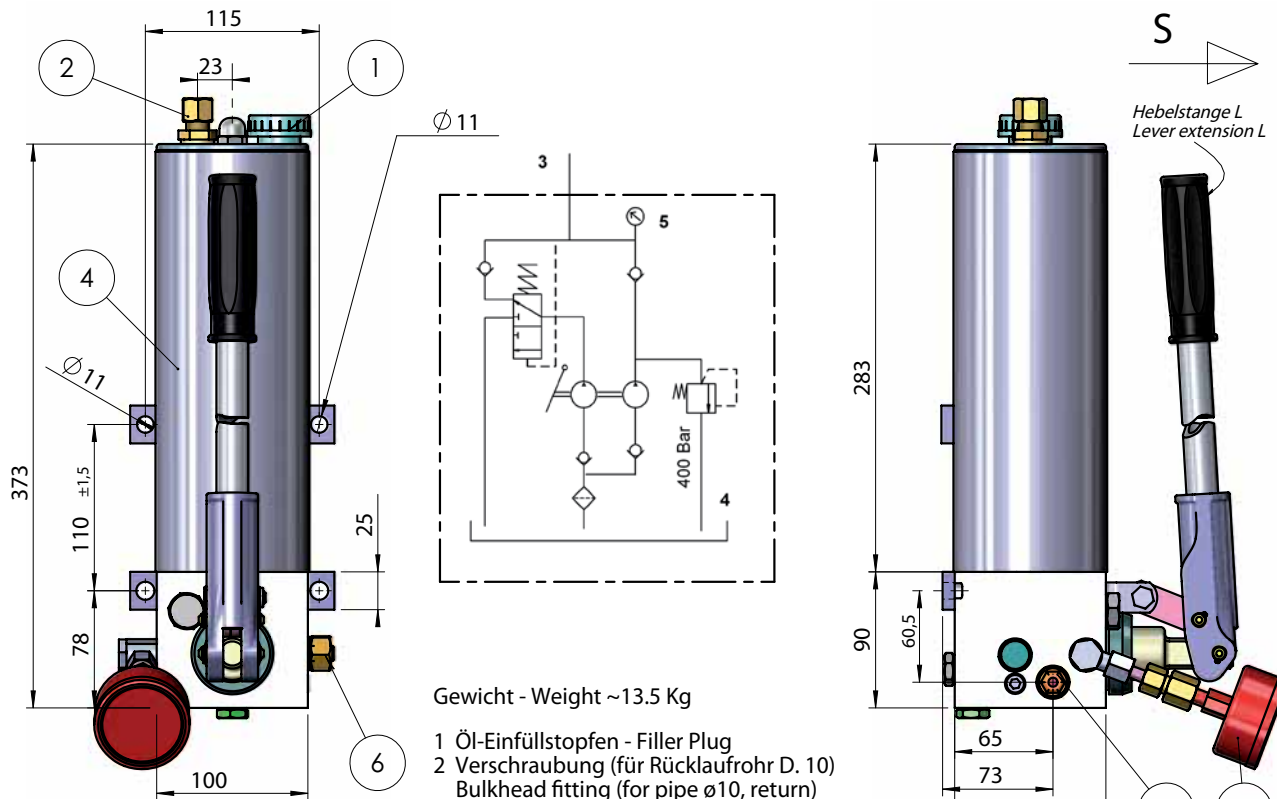

Gewicht - Weight ~13.5 Kg

- 1 Öl-Einfüllstopfen - Filler Plug
- 2 Verschraubung (für Rücklaufrohr D. 10)  
Bulkhead fitting (for pipe ø10, return)
- 3 Verschraubung Druckanschluss (für Rohr. D. 6)  
Bulkhead fitting (for pipe ø6)
- 4 Tank 1,7l
- 5 Manometer ø63 (1/4" Gas bspp)  
Pressure gauge ø63 (1/4" Gas bspp)
- 6 Druckbegrenzungsventil - Relief Valve

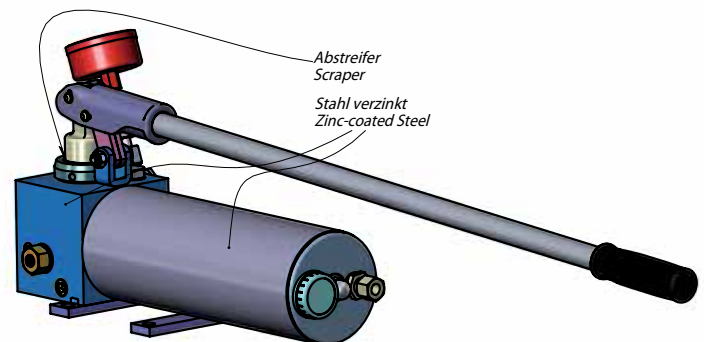
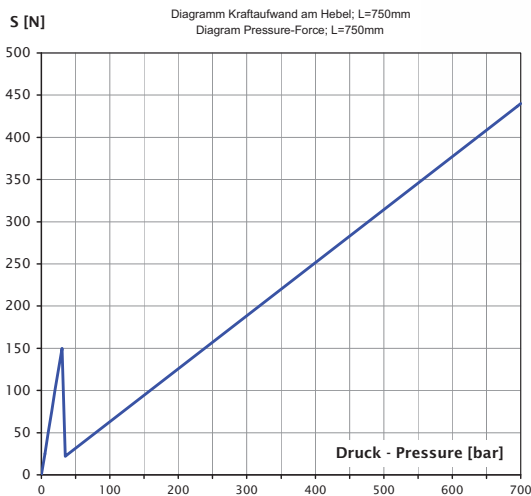
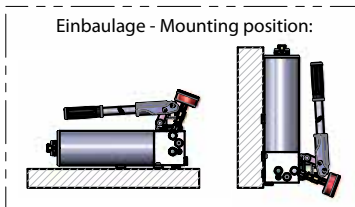

TYP TYPE	Fördervolumen (1° Stufe / 2° Stufe) Displacement (1° speed / 2° speed) [cm³]	Druck (1° Stufe / 2° Stufe) Pressure (1° speed / 2° speed) [bar]
GL241F3	~20 / 3	~25 / 400 (max 700)

Unverbindliche Angaben. Änderungen vorbehalten. - Dimensions not binding. Modifications reserved without prior notice.  
Property of HANSA-TMP SRL. Copying without authorisation will be persecuted by Law.  
Eigentum von HANSA-TMP SRL. Nicht genehmigtes Kopieren wird strafrechtlich verfolgt.

### Pumpe Typ GLAPN - Pump Type GLAPN

Einfachhub mit Pedal, für einfachwirkenden Zylinder  
Single acting with foot-pedal for single acting cylinder

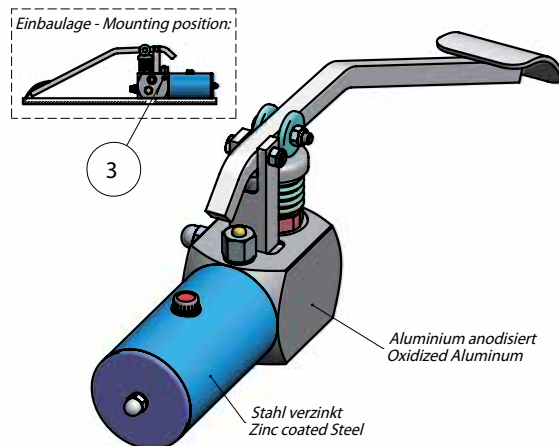
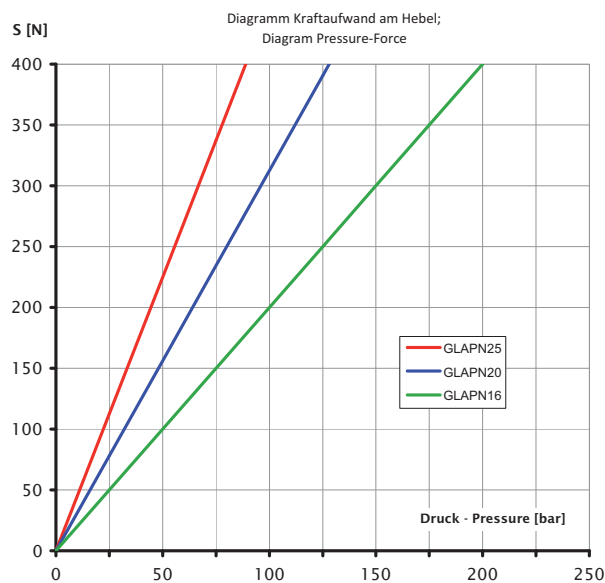
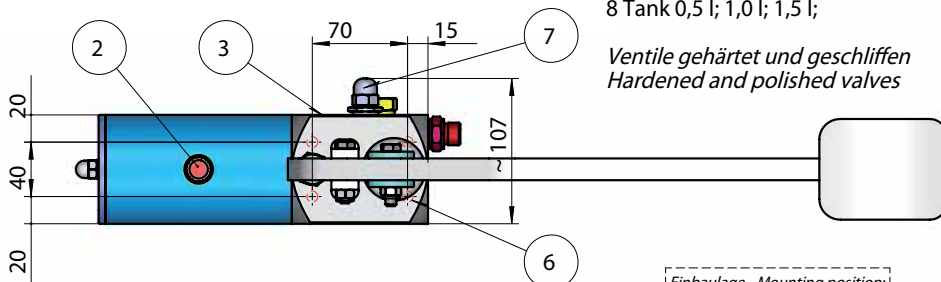
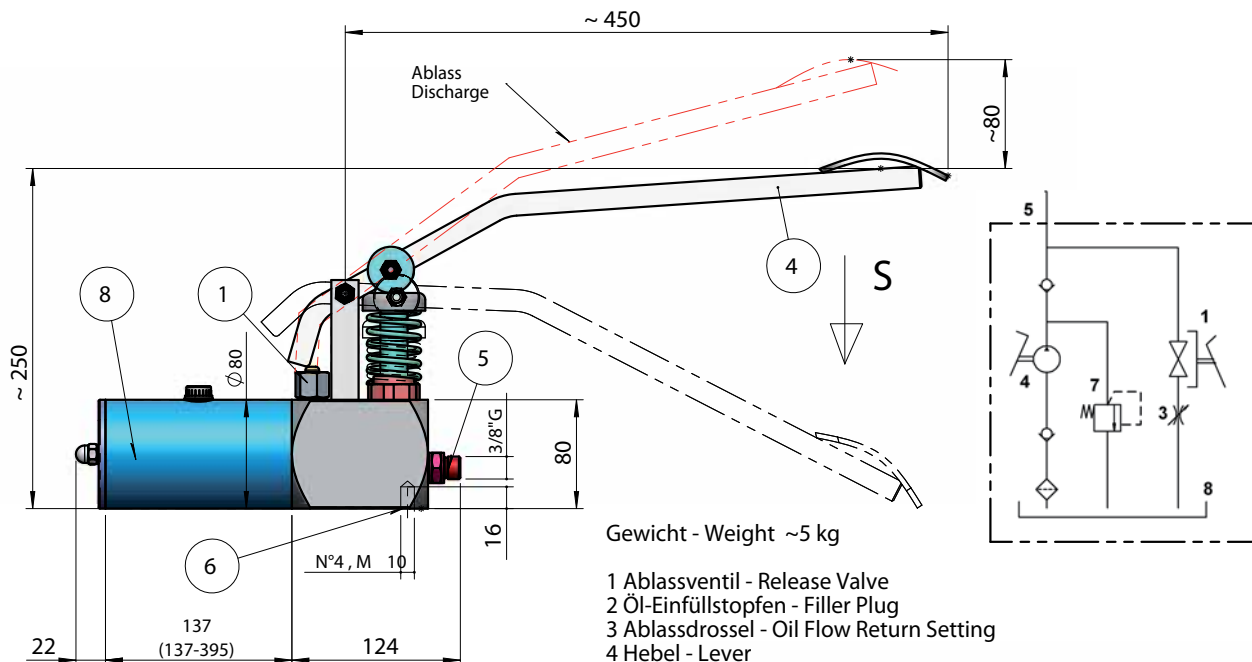

TYP TYPE	Fördervolumen Displacement [cm³]	Druck Pressure [bar]
GLAPN16	3,2	250
GLAPN20	5	160
GLAPN25	7,5	100

Unverbindliche Angaben. Änderungen vorbehalten. - Dimensions not binding. Modifications reserved without prior notice.  
Property of HANSA-TMP SRL. Copying without authorisation will be persecuted by Law.  
Eigentum von HANSA-TMP SRL. Nicht genehmigtes Kopieren wird strafrechtlich verfolgt.

### Pumpe Typ GL100P - Pump Type GL100P

Einfachhub mit Pedal, für einfachwirkenden Zylinder  
Single Acting with foot-pedal for single acting cylinder

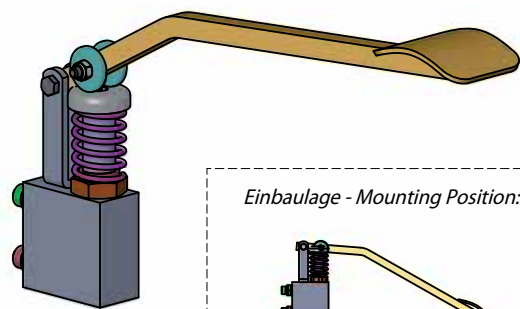
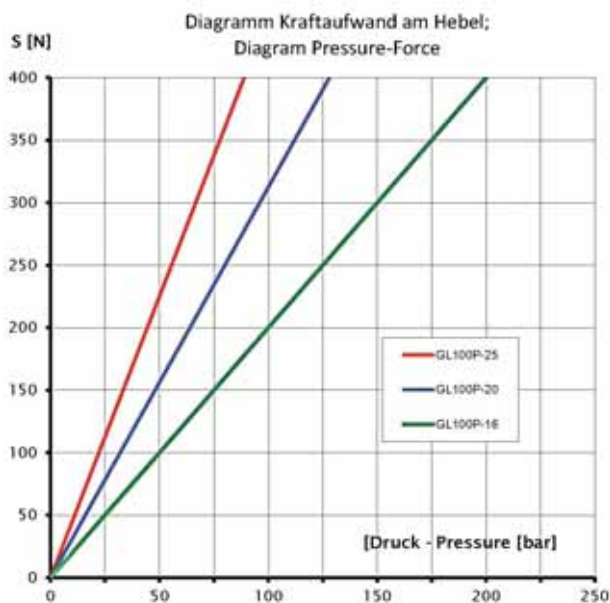
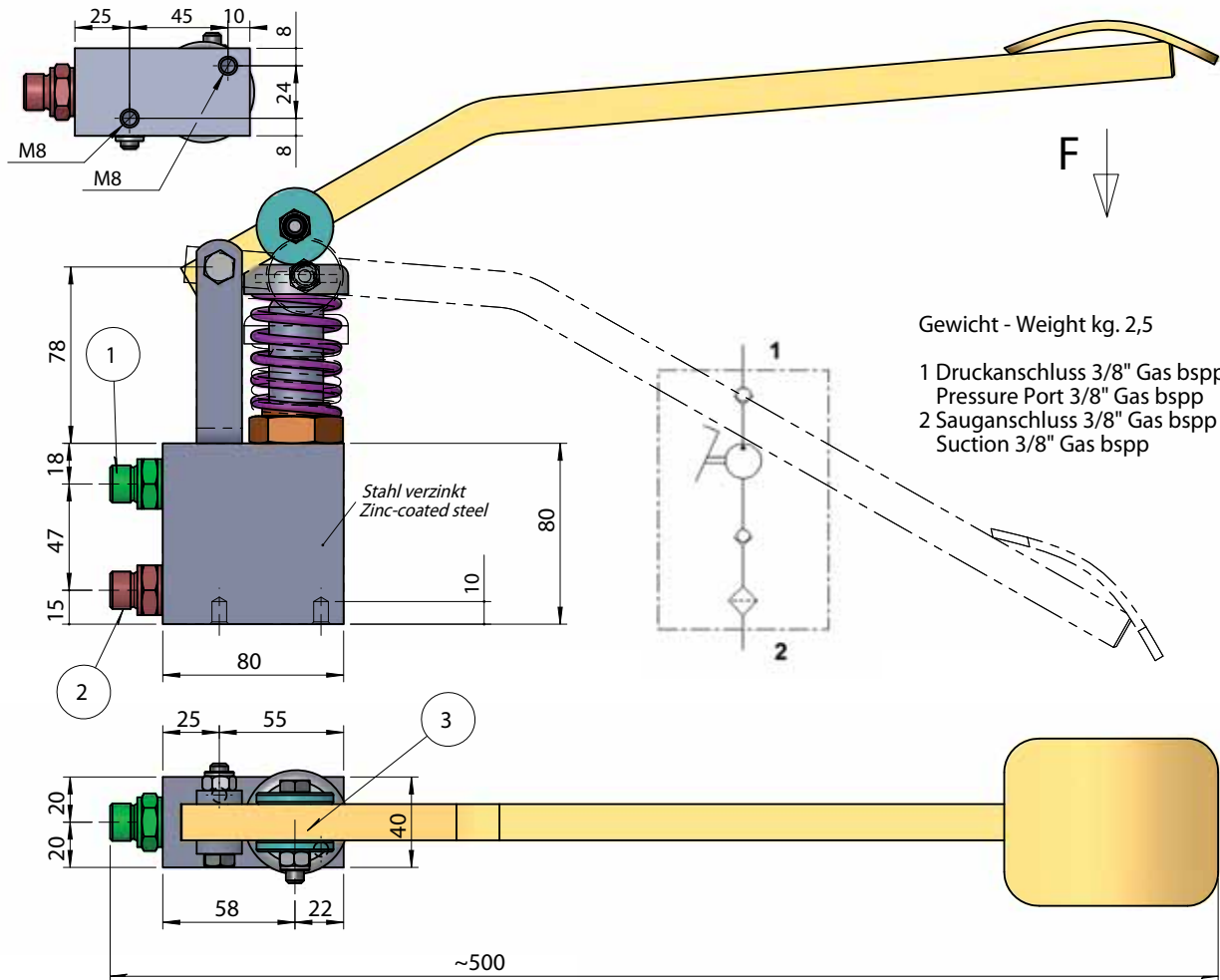

TYP TYPE	Fördervolumen Displacement [cm³]	Druck Pressure [bar]
GL100P-16	3,2	250
GL100P-20	5	160
GL100P-25	7,5	100

Unverbindliche Angaben. Änderungen vorbehalten. - Dimensions not binding. Modifications reserved without prior notice.  
Property of HANSA-TMP SRL. Copying without authorisation will be persecuted by Law.  
Eigentum von HANSA-TMP SRL. Nicht genehmigtes Kopieren wird strafrechtlich verfolgt.

### Pumpe Typ GL115MPAL - Pump Type GL115MPAL

2-Stufen-Pumpe, Einfachhub für einfachwirkenden Zylinder  
2 Speed, single acting function for single acting cylinder

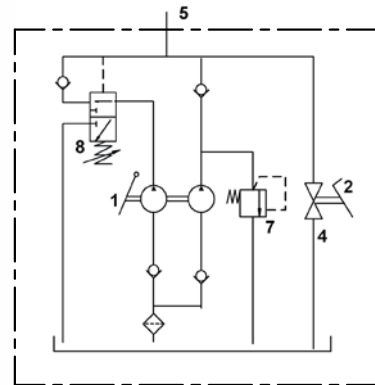
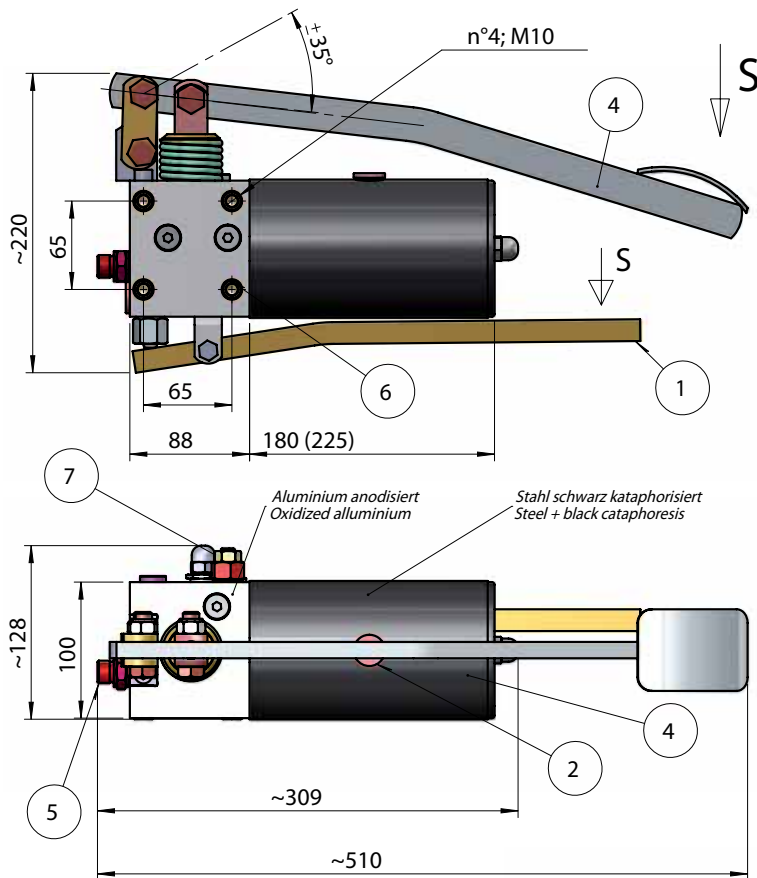

Gewicht - Weight Kg. ~8  
Druck - Pressure Bar 420

Öltank ≈ 1 l; (1.5 l)  
Oil Tank ≈ 1 l; (1.5 l)

Einbaulage - Working Position:

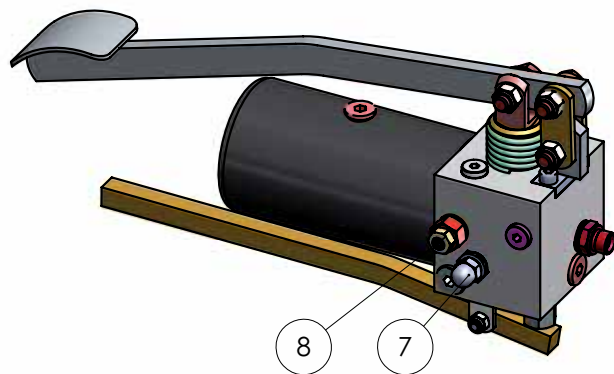
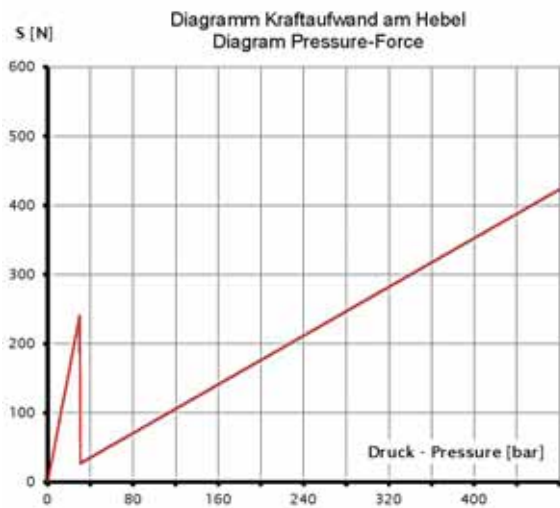
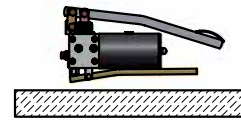

Funktion Funzionamento	Fördervolumen Displacement [cm <sup>3</sup> ]	Druck Pressure [bar]
1° Stufe - Speed	~18	~15 - 35
2° Stufe - Speed	~3,0	~420

- 1 Hebel Ablassventil - Discharge Lever
- 2 Öl-Einfüllstopfen - Filler Plug
- 4 Pumpedal - Foot Pedal
- 5 Druckanschluss (3/8" Gas bspp) - Pressure Port (3/8" Gas bspp)
- 6 Befestigungsbohrungen - Mounting Holes
- 7 Druckbegrenzungsventil - Relief Valve
- 8 Bypassventil - Bypass Valve

Unverbindliche Angaben. Änderungen vorbehalten. - Dimensions not binding. Modifications reserved without prior notice.  
Property of HANSA-TMP SRL. Copying without authorisation will be persecuted by Law.  
Eigentum von HANSA-TMP SRL. Nicht genehmigtes Kopieren wird strafrechtlich verfolgt.

### Pumpe Typ GL144PAL - Pump Type GL144PAL

*Einfachhub mit Pedal, für einfachwirkenden Zylinder*  
*Single Acting with foot-pedal function for single acting cylinder*

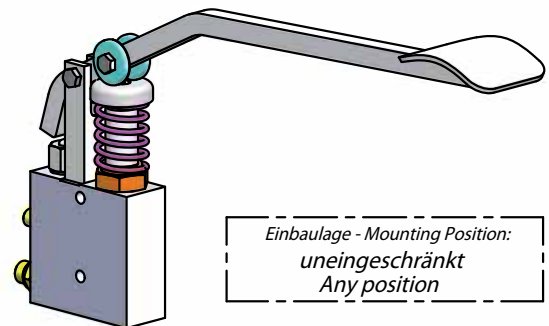
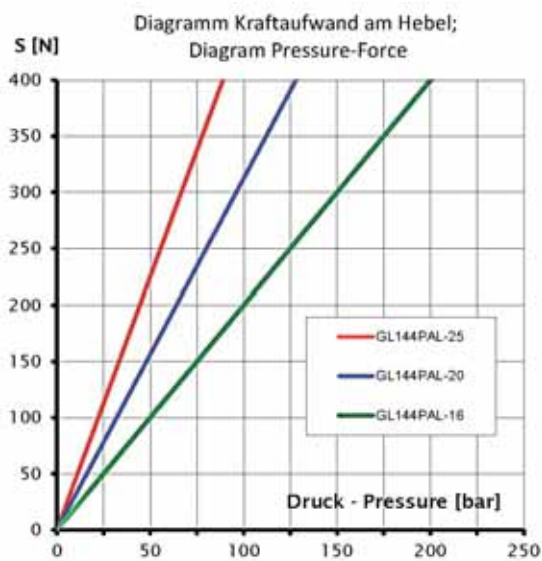
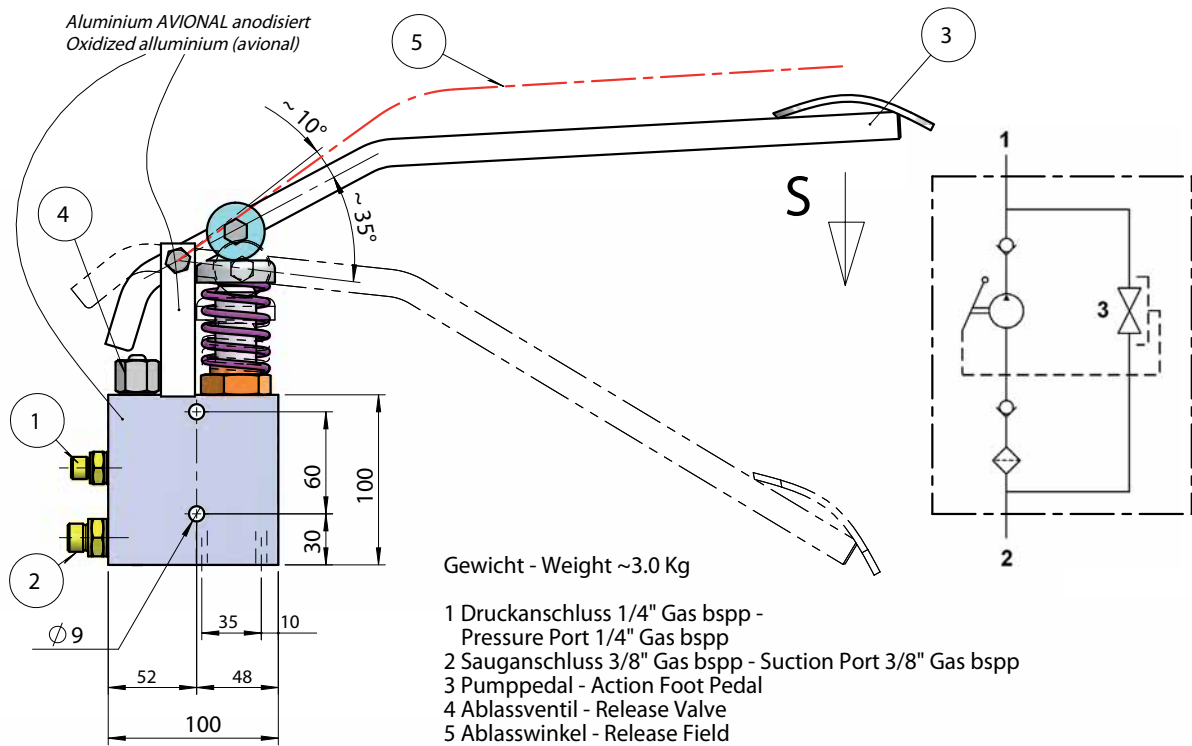
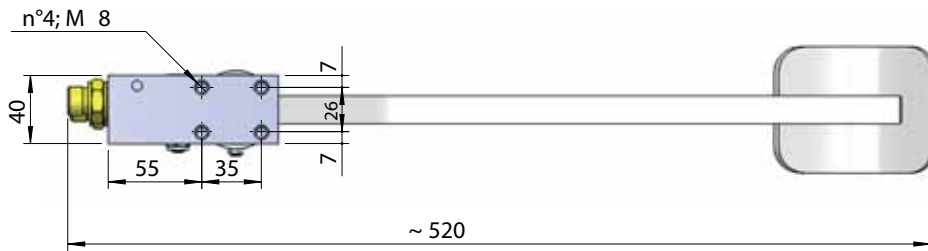

TYP TYPE	Fördervolumen Displacement [cm <sup>3</sup> ]	Druck Pressure [bar]
GL144PAL-16	4,5	250
GL144PAL-20	7	160
GL144PAL-25	10,5	100

Unverbindliche Angaben. Änderungen vorbehalten. - Dimensions not binding. Modifications reserved without prior notice.  
Property of HANSA-TMP SRL. Copying without authorisation will be persecuted by Law.  
Eigentum von HANSA-TMP SRL. Nicht genehmigtes Kopieren wird strafrechtlich verfolgt.

### Pumpe Typ GL219 - Pump Type GL219

Einfach-Hubfunktion für einfachwirkende Zylinder  
Single-acting function for single acting cylinder

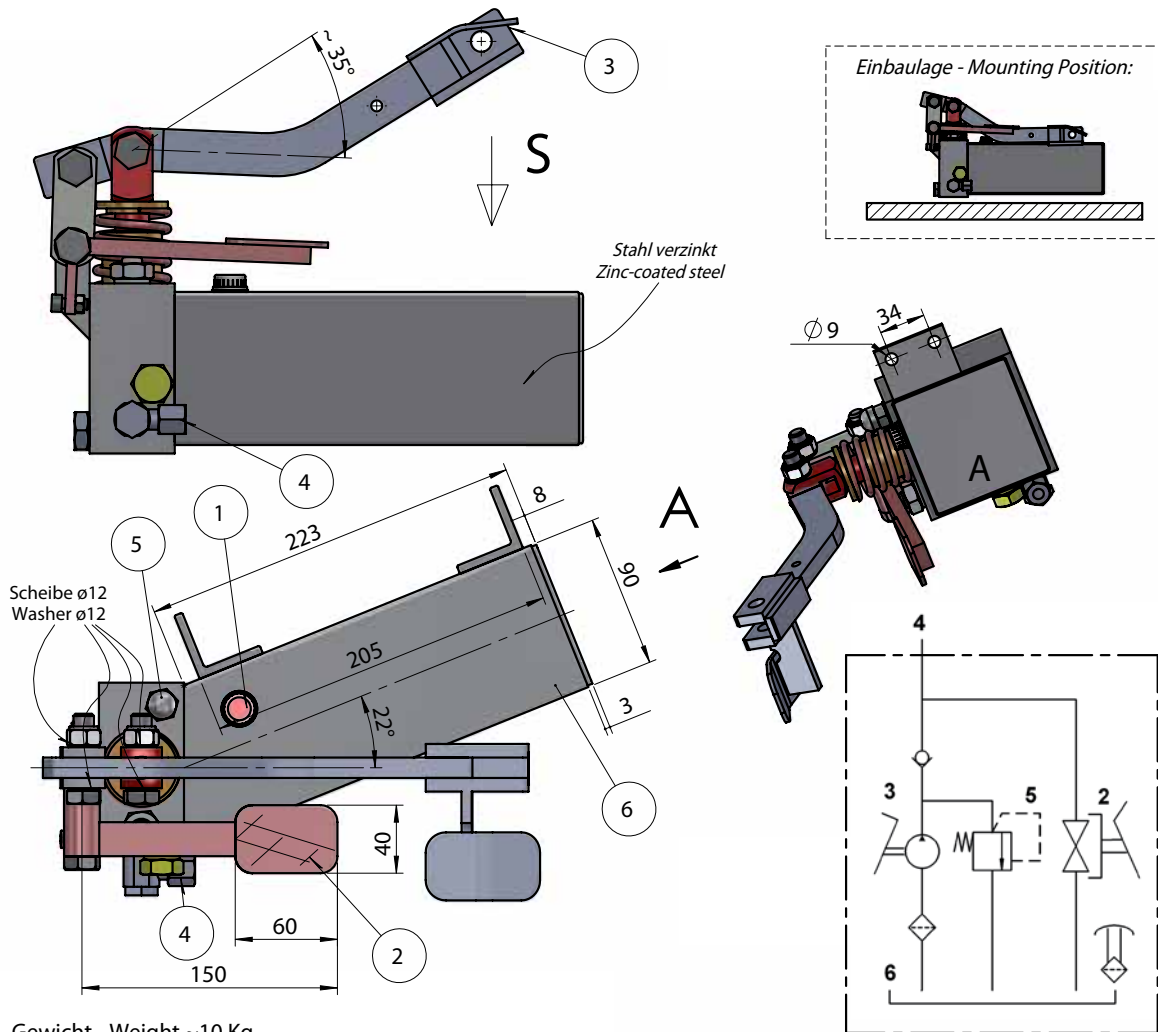

Gewicht - Weight ~10 Kg

- 1 Öl-Einfüllstopfen - Filler Plug
- 2 Ablasspedal - Release Foot Pedal
- 3 Pumpedal - Foot Pedal
- 4 Druckanschluss (1/4" Gas bsp) für Rohr ø8 - Pressure port (1/4" Gas bsp) for pipe ø8
- 5 Druckbegrenzungsventil - Relief Valve Setting
- 6 Tank 1,2 l

\*Innenliegende Ventile gehärtet und geschliffen - Hardened and polished internal valves

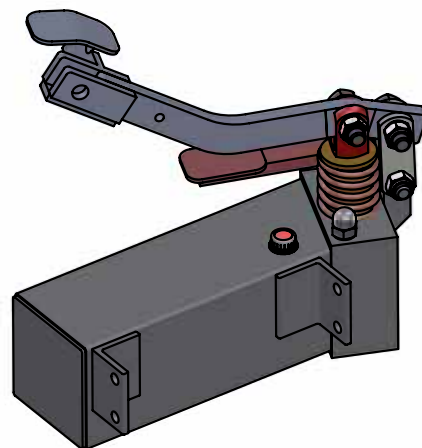
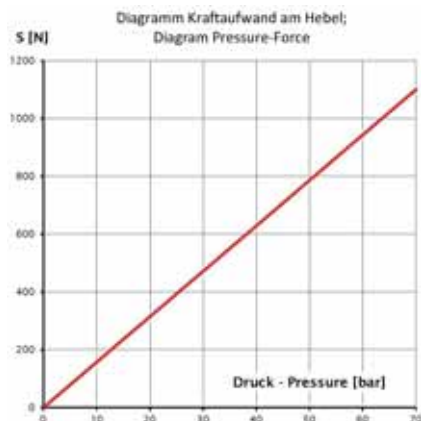

TYP TYPE	Fördervolumen Displacement [cm³]	Druck Pressure [bar]
GL219	19	65

Unverbindliche Angaben. Änderungen vorbehalten. - Dimensions not binding. Modifications reserved without prior notice.  
Property of HANSA-TMP SRL. Copying without authorisation will be persecuted by Law.  
Eigentum von HANSA-TMP SRL. Nicht genehmigtes Kopieren wird strafrechtlich verfolgt.



### Pumpe Typ GL12C - Pump Type GL12C

*Einfach-Hub, mit integriertem einfachwirkenden Zylinder*  
*Single acting function with built-in single acting cylinder*

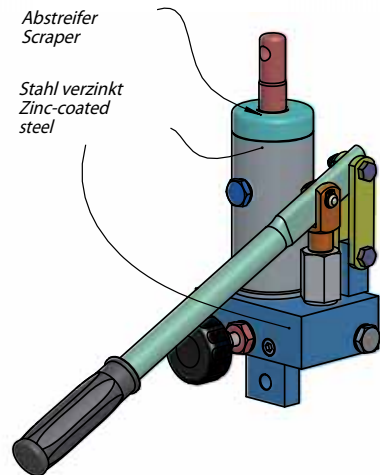
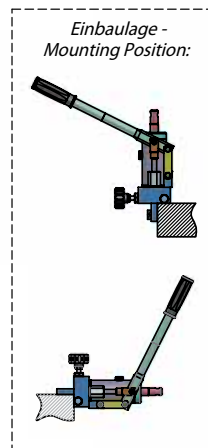
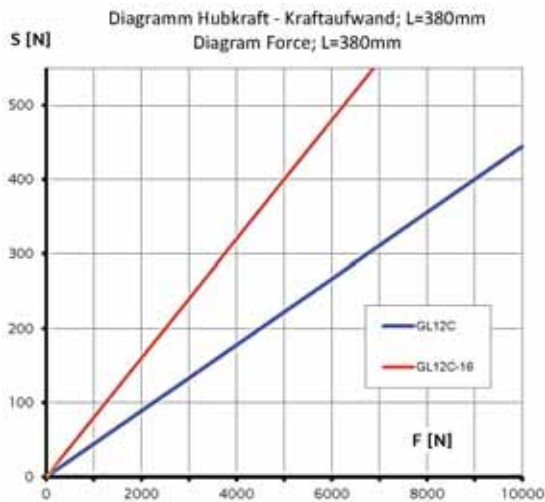
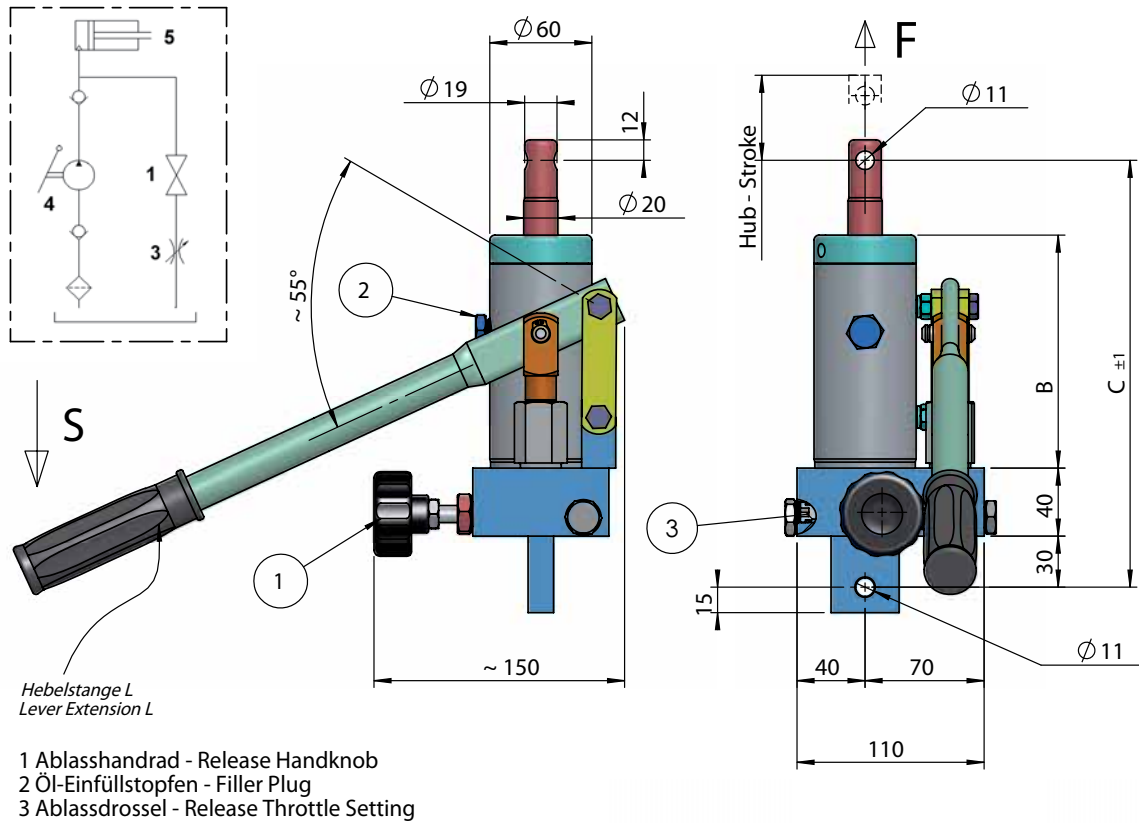

\* Bitte gewünschten Hub angeben - Mention required stroke

TYP TYPE	Hub Stroke [mm]	Förderleistung Displacement [cm <sup>3</sup> ]	Hub pro Pumpzyklus Stroke Cycle [mm]	Hubkraft F Force F [N]	B [mm]	C [mm]	Tank [L]	Gewicht Weight [kg]
GL12C	130	3,6	~10	9000	137	253	0,1	6
*GL12C-xxx	xxx	3,6	~10	9000	xxx+7	xxx+123	-	-
GL12C-16	130	6,6	~20	5000	137	253	0,1	6
*GL12C-16-xxx	xxx	6,6	~20	5000	xxx+7	xxx+123	-	-

Unverbindliche Angaben. Änderungen vorbehalten. - Dimensions not binding. Modifications reserved without prior notice.  
Property of HANSA-TMP SRL. Copying without authorisation will be persecuted by Law.  
Eigentum von HANSA-TMP SRL. Nicht genehmigtes Kopieren wird strafrechtlich verfolgt.

### Pumpe Typ GL21C40AL - Pump Type GL21C40AL

*Doppelhub-Funktion mit integriertem einfachwirkenden Zylinder*  
*Double-stroke function with built-in single acting cylinder*

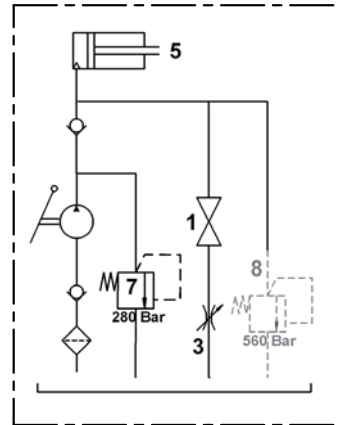
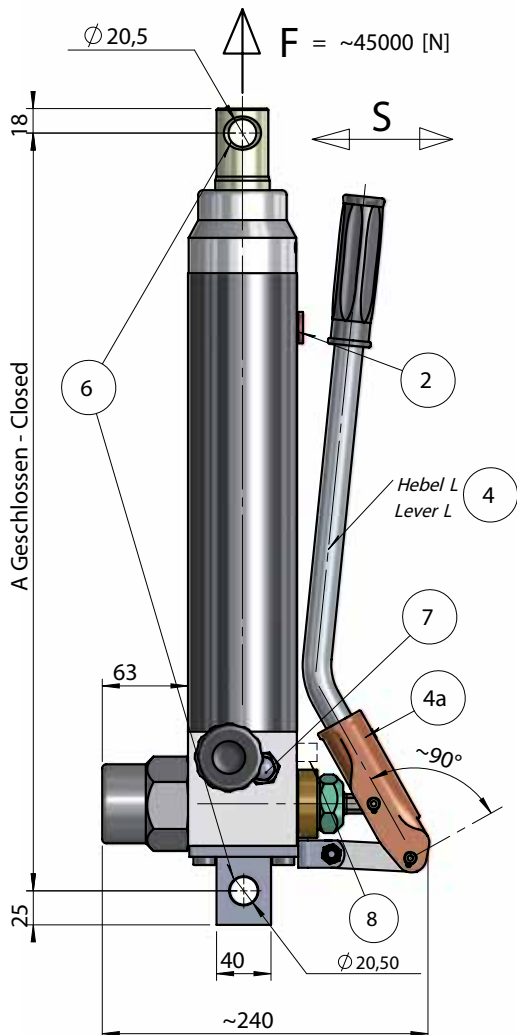

- 1 Ablasshandrad - Release Handknob
- 2 Öleinfüllstopfen - Filler Plug
- 3 Ablassdrossel - Release Throttle
- 4 Hebelstange - Lever Extension
- 4a Pumphebel - Lever
- 5 Kolbenstange - Cylinder Rod
- 6 Befestigungsbohrungen - Mounting Holes
- 7 Druckbegrenzungsventil - Relief Valve
- 8 Druckbegrenzungsventil (auf Wunsch) - Safety valve (on request)

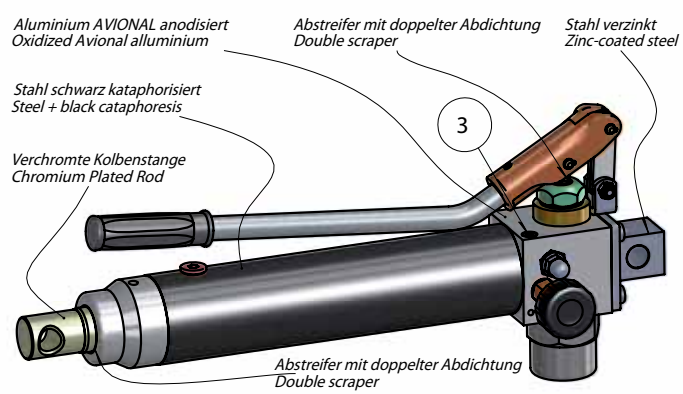
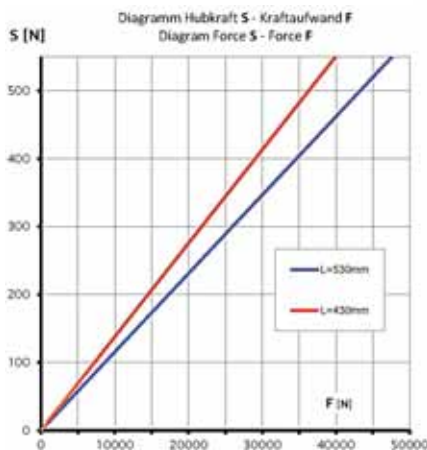
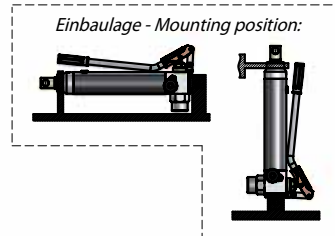

TYP TYPE	Hub Stroke [mm]	Förderleistung Displacement [cm <sup>3</sup> ]	Hub pro Pumpzyklus Stroke Cycle [mm]	Hubkraft F Force F [N]	A [mm]	L [mm]	Tank [L]	Gewicht Weight [kg]
GL21C40AL-305	305	21	12	45000	557	430	0,6	14
GL21C40AL-600	600	21	12	45000	852	530	1,3	21

*Unverbindliche Angaben. Änderungen vorbehalten. - Dimensions not binding. Modifications reserved without prior notice.*  
*Property of HANSA-TMP SRL. Copying without authorisation will be persecuted by Law.*  
*Eigentum von HANSA-TMP SRL. Nicht genehmigtes Kopieren wird strafrechtlich verfolgt.*

### Pumpe Typ GL24C - Pump Type GL24C

Einfach-Hub, mit integriertem einfachwirkenden Zylinder  
Single acting function with built-in single acting cylinder

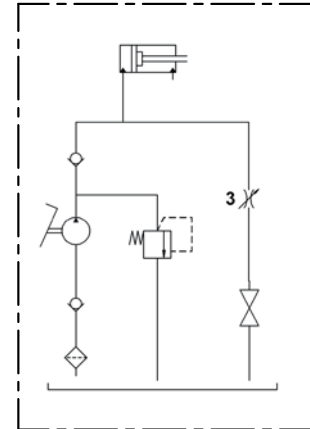
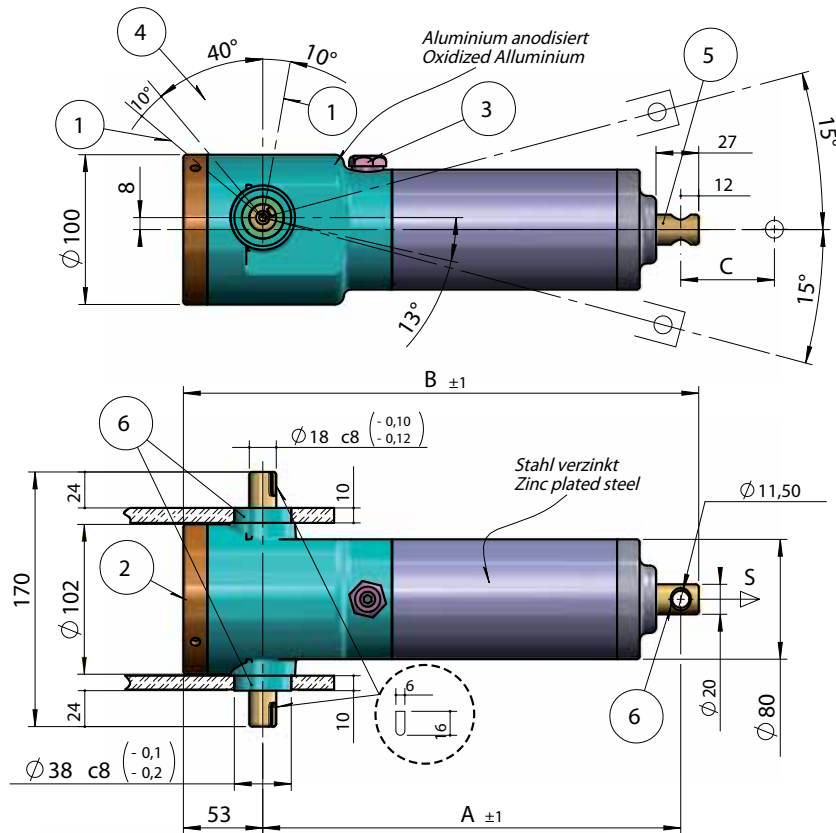

- 1 Ablassbereich - Release Field
- 2 Öl-Einfüllstopfen - Filler Plug
- 3 Ablassdrossel - Release Throttle
- 4 Bereich Pumpedal - Pedal Pumping Field
- 5 Kolbenstange - Cylinder Rod
- 6 Befestigungen - Mounting Points

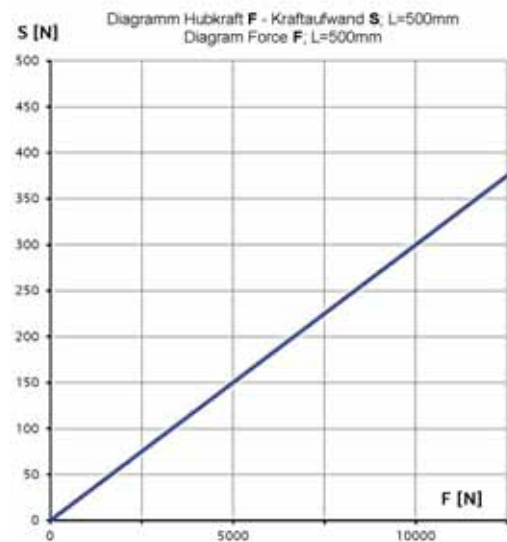
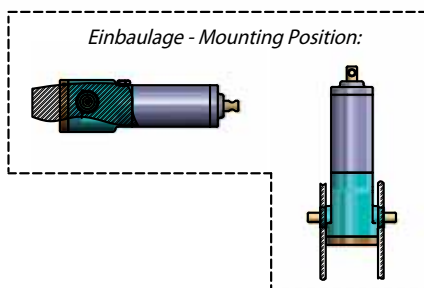

\* Auf Wunsch - \* On request;

TYP TYPE	Hub Stroke [mm]	Förderleistung Displacement [cm <sup>3</sup> ]	Hub pro Pumpzyklus Stroke Cycle [mm]	Hubkraft F Force F [N]	A [mm]	B [mm]	Tank [L]	Gewicht Weight [kg]
GL24C-135	135	8	12	9800	280	345	0,3	5,4
*GL24C-150	150	8	12	9800	295	350	0,3	5,7
GL24C-200	200	8	12	9800	345	410	0,4	6,2
GL24C-284	284	8	12	9800	429	494	0,4	7,3
*GL24C-300	300	8	12	9800	445	510	0,6	7,6
*GL24C-400	400	8	12	9800	545	610	0,8	9

Unverbindliche Angaben. Änderungen vorbehalten. - Dimensions not binding. Modifications reserved without prior notice.  
Property of HANSA-TMP SRL. Copying without authorisation will be persecuted by Law.  
Eigentum von HANSA-TMP SRL. Nicht genehmigtes Kopieren wird strafrechtlich verfolgt.

### Pumpe Typ GLT10-ALW - Pump Type GLT10-ALW

Einfachwirkend, mit integriertem einfachwirkenden Zylinder mit Federrückzug  
Single acting function with built-in single acting cylinder with spring return

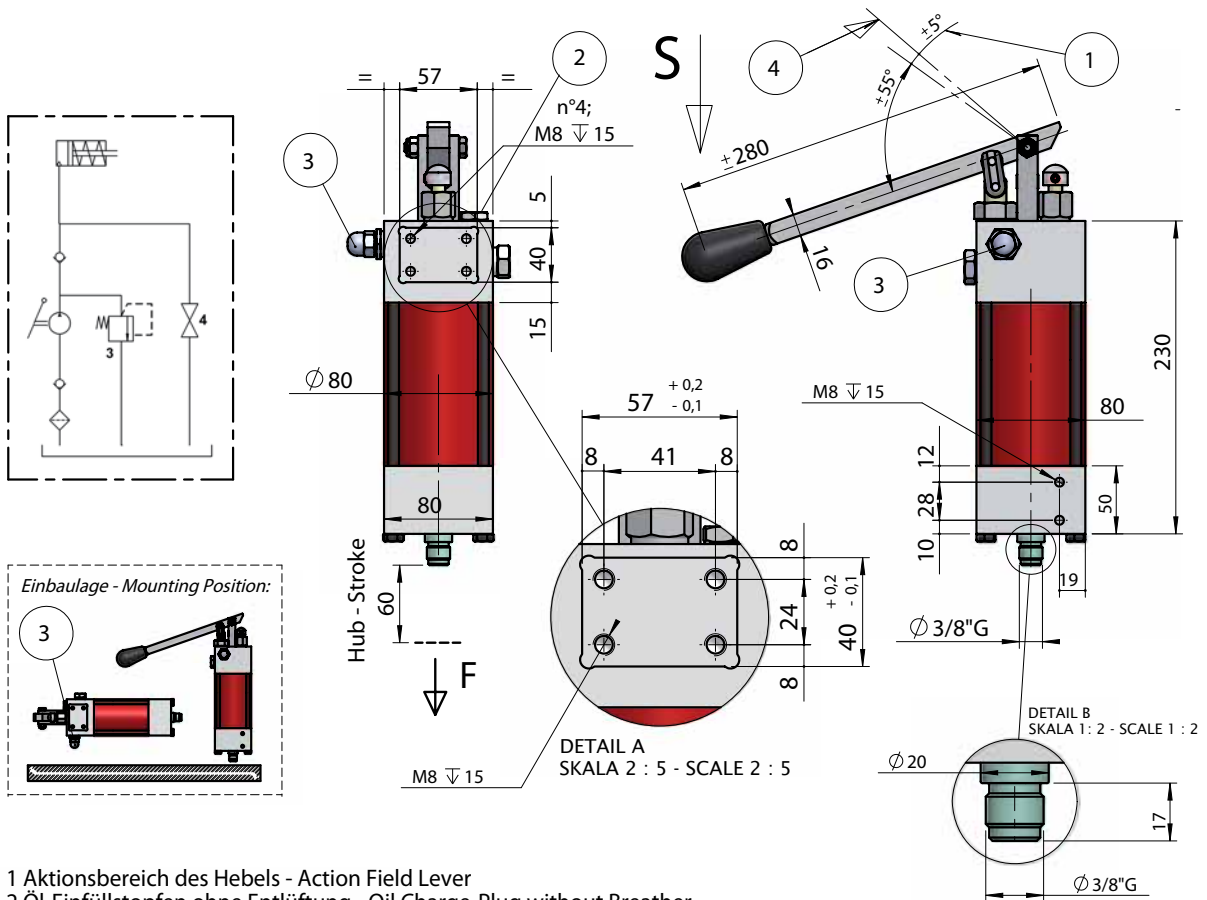

- 1 Aktionsbereich des Hebels - Action Field Lever
- 2 Öl-Einfüllstopfen ohne Entlüftung - Oil Charge-Plug without Breather
- 3 Max-Druckeinstellung - Relief Valve Setting
- 4 Ablassbereich - Release Field

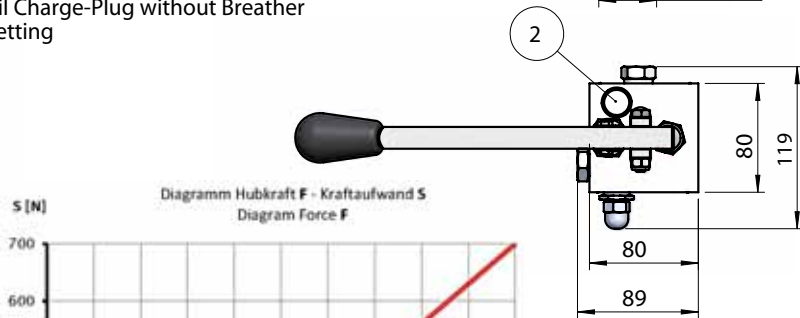
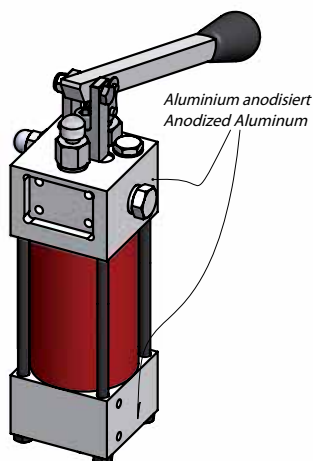

TYP TYPE	Hub Stroke [mm]	Förderleistung pro Pumpzyklus Displacement*Cycle [cm <sup>3</sup> ]	Hub pro Pumpzyklus Stroke*Cycle [mm]	Hubkraft S Force S [N]	Tank [L]	Gewicht Weight [kg]
GLT10-ALW	60	5,2	7	20000	0,13	6

Unverbindliche Angaben. Änderungen vorbehalten. - Dimensions not binding. Modifications reserved without prior notice.  
Property of HANSA-TMP SRL. Copying without authorisation will be persecuted by Law.  
Eigentum von HANSA-TMP SRL. Nicht genehmigtes Kopieren wird strafrechtlich verfolgt.

### Pumpe Typ GTE - Pump Type GTE

*Einfach-Hub, mit integriertem einfachwirkenden Zylinder*  
*Single Acting function with built-in single acting cylinder*

- 1 Ablasshandrad - Release Handknob
- 2 Öl-Einfüllstopfen - Filler Plug
- 3 Ablassdrossel - Release Throttle
- 4 Pumphebel - Lever
- 5 Kolbenstange Ø30 - Piston Rod Ø 30
- 6 Befestigungsbohrungen - Fixing Holes
- 7 Schutzkappe (auf Anfrage) - Piston Protection (on request)

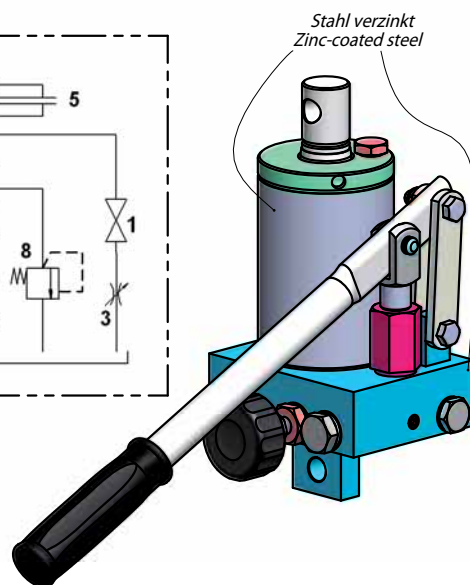
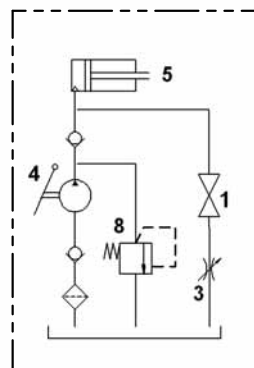
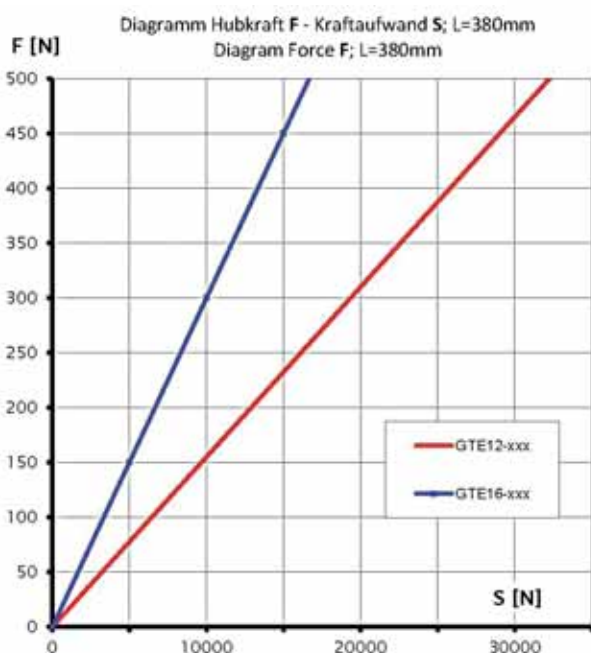
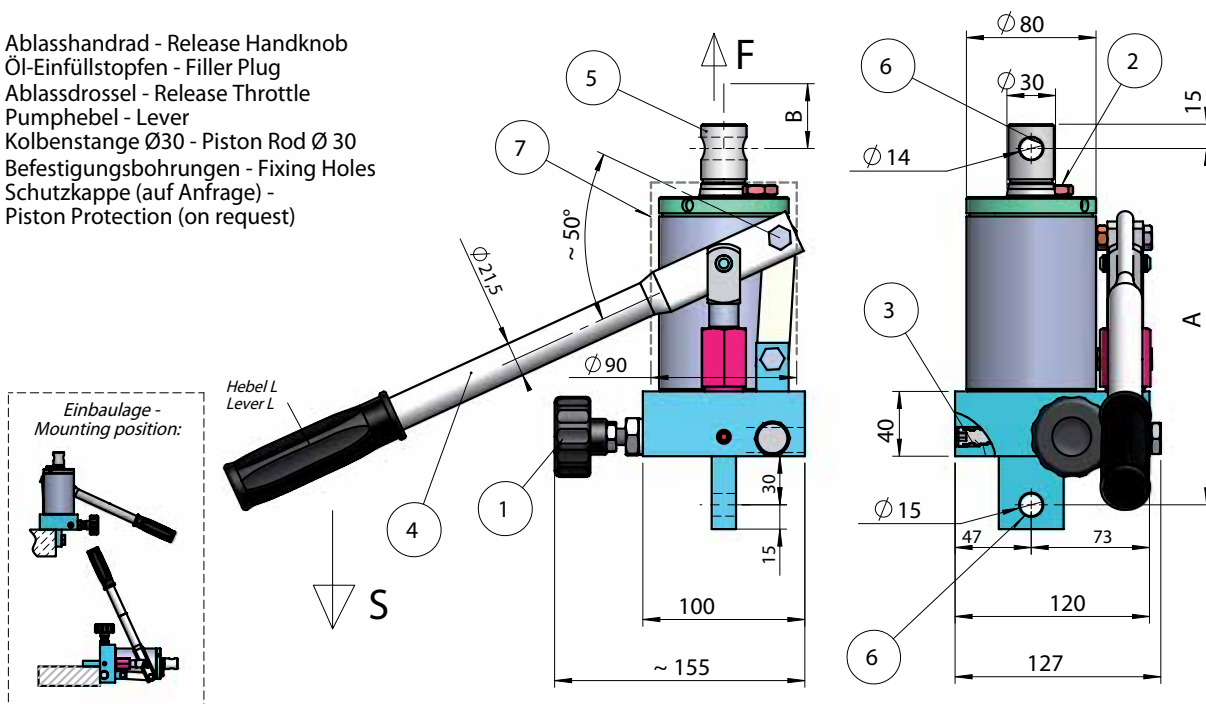

TYP TYPE	Hub B Stroke B [mm]	Förderleistung Displacement [cm <sup>3</sup> ]	Hub pro Pumpzyklus Stroke Cycle [mm]	Hubkraft F Force F [N]	A [mm]	Tank [L]	Gewicht Weight [kg]
GTE12-100	100	3,7	5	31000	220	0,21	~9
GTE12-200	200	3,7	5	31000	320	0,42	~13
GTE16-100	100	6,7	9	17000	220	0,21	~9
GTE16-200	200	6,7	9	17000	320	0,42	~13
*GTE(12/16)-xxx	xxx	3,7/6,7	(5/9)	31000/17000	120+xxx	-	-

*Unverbindliche Angaben. Änderungen vorbehalten. - Dimensions not binding. Modifications reserved without prior notice.  
Property of HANSA-TMP SRL. Copying without authorisation will be persecuted by Law.  
Eigentum von HANSA-TMP SRL. Nicht genehmigtes Kopieren wird strafrechtlich verfolgt.*

### Pumpe Typ GL224(P) - Pump Type GL224(P)

*Einfach-Hub, mit integriertem einfachwirkenden Zylinder*  
*Single Acting function with built-in single acting cylinder*

- 1 Pumpedal - Foot Pedal
- 2 Ablasspedal - Unloading Foot Pedal
- 3 Öl-Einfüllstopfen - Filler Plug
- 4 Befestigungsbohrungen - Fixing Holes
- 5 Ablassdrossel - Unloading Throttle
- 6 Druckbegrenzungsventil - Relief Valve

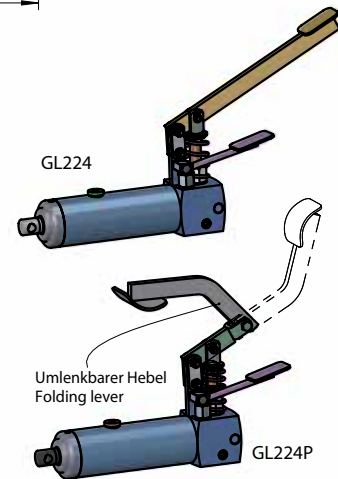
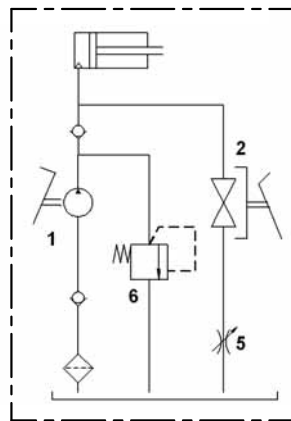
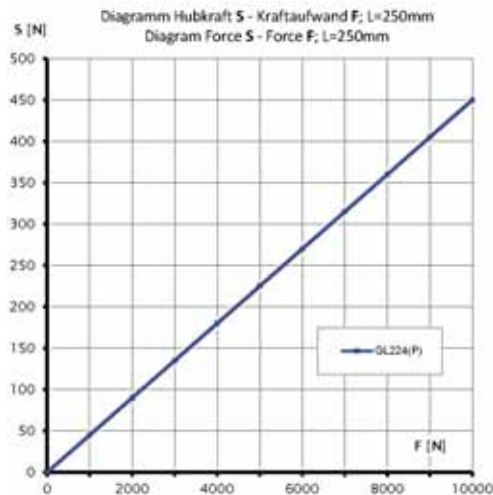
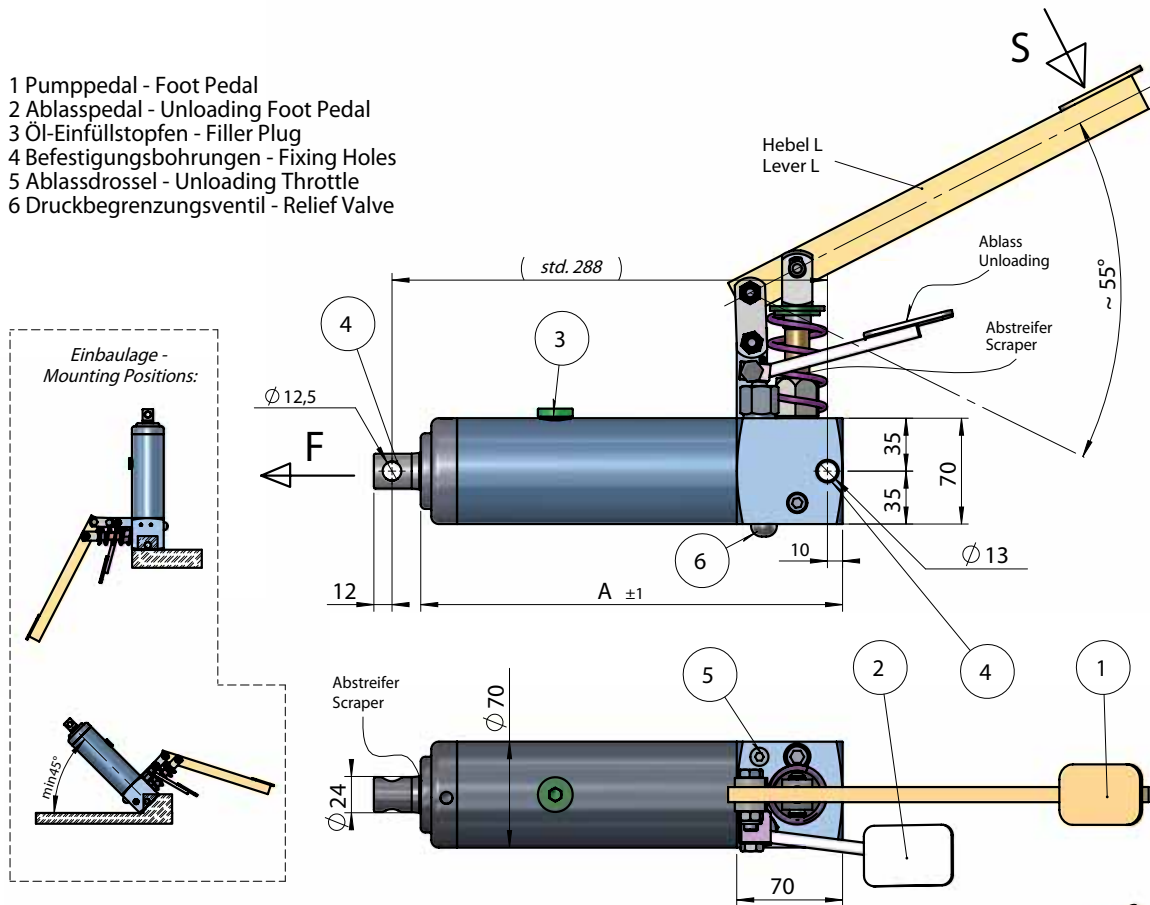

TYP TYPE	Hub B Stroke B [mm]	Förderleistung Displacement [cm <sup>3</sup> ]	Hub pro Pumpzyklus Stroke Cycle [mm]	Hubkraft F Force F [N]	A [mm]	Tank [L]	Gewicht Weight [kg]
GL224	150	6,5	8	9000	272	0,35	~9
*GL224-xxx	xxx	6,5	8	9000	xxx + 122	-	-
GL224P	150	6,5	8	9000	272	0,35	~9
*GL224P-xxx	xxx	6,5	8	9000	xxx + 122	-	-

\* Andere Hublängen auf Anfrage - Ask availability for different strokes

Unverbindliche Angaben. Änderungen vorbehalten. - Dimensions not binding. Modifications reserved without prior notice.  
Property of HANSA-TMP SRL. Copying without authorisation will be persecuted by Law.  
Eigentum von HANSA-TMP SRL. Nicht genehmigtes Kopieren wird strafrechtlich verfolgt.

### Pumpe Typ GL229 - Pump Type GL229

Einfach-Hub, mit integriertem einfachwirkenden Zylinder  
Single Acting function with built-in single acting cylinder

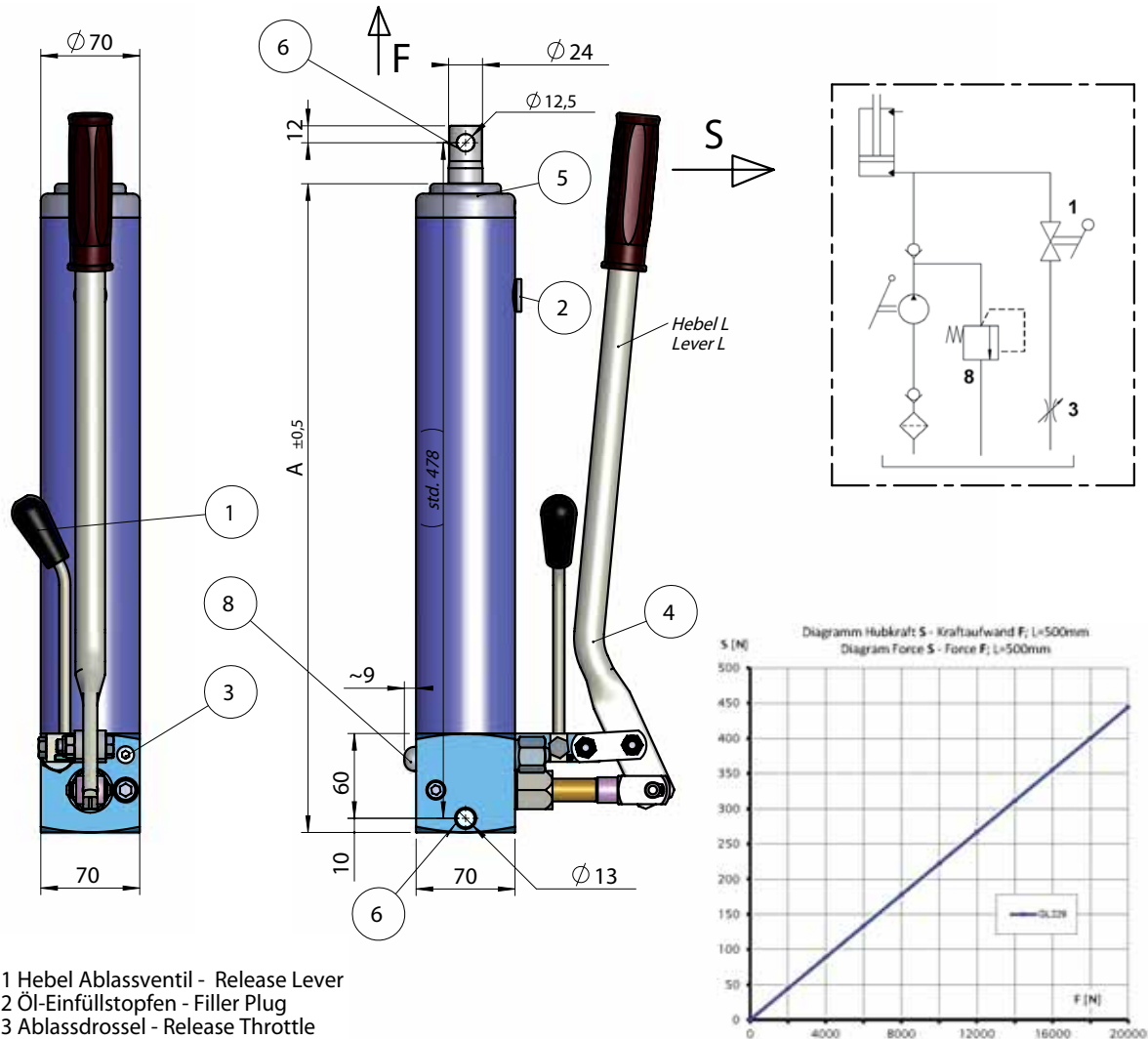

- 1 Hebel Ablassventil - Release Lever
- 2 Öl-Einfüllstopfen - Filler Plug
- 3 Ablassdrossel - Release Throttle
- 4 Pumphebel - Lever
- 5 Kolbenstange - Cylinder Rod
- 6 Befestigungsbohrungen - Fixing Holes
- 8 Druckbegrenzungsventil - Relief Valve

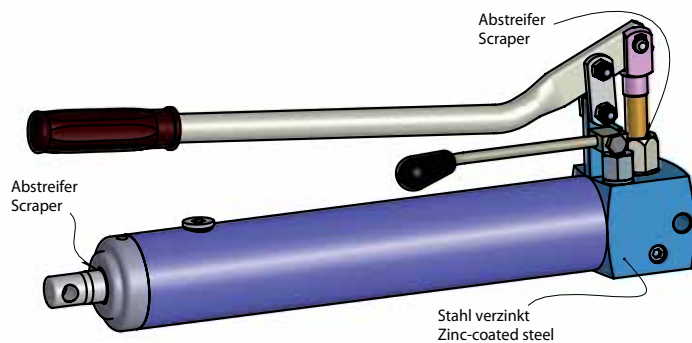
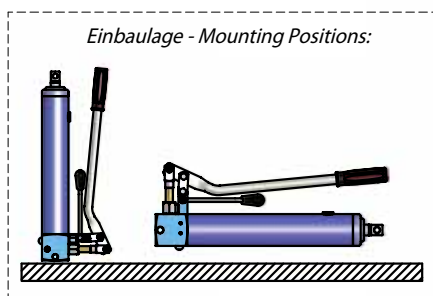

TYP TYPE	Hub B Stroke B [mm]	Förderleistung Displacement [cm <sup>3</sup> ]	Hub pro Pumpzyklus Stroke Cycle [mm]	Hubkraft F Force F [N]	A [mm]	Tank [L]	Gewicht Weight [kg]
GL229	330	6,5	8	18000	459	0,8	~11
*GL229-xxx	xxx	6,5	8	18000	xxx + 129	-	-

\* Bitte gewünschten Hub angeben - Ask availability for different strokes

Unverbindliche Angaben. Änderungen vorbehalten. - Dimensions not binding. Modifications reserved without prior notice.  
Property of HANSA-TMP SRL. Copying without authorisation will be persecuted by Law.  
Eigentum von HANSA-TMP SRL. Nicht genehmigtes Kopieren wird strafrechtlich verfolgt.

### Pumpe Typ GL239-HAL - Pump Type GL239-HAL

Fusspedalpumpe. Einfachwirkend, mit integriertem einfachwirkenden Zylinder  
Foot pedal pump. Single acting function with built-in single acting cylinder

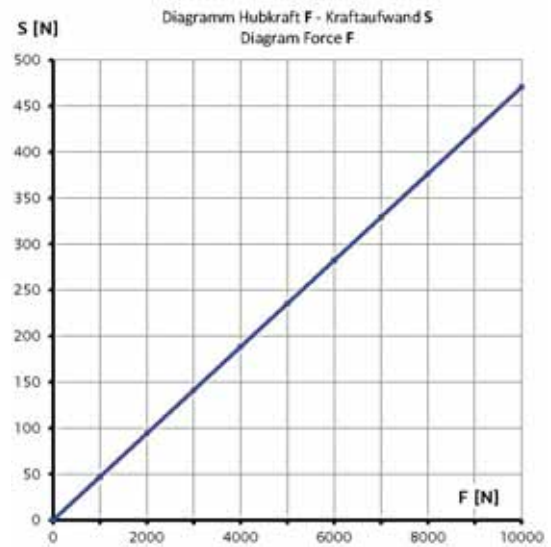
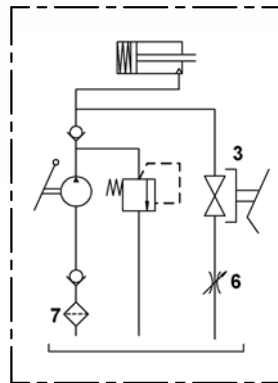
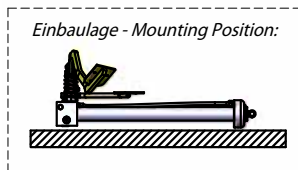
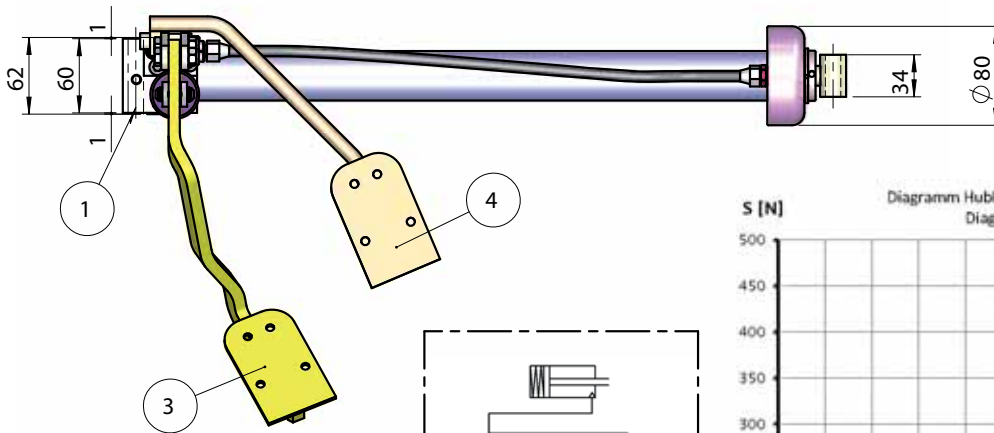
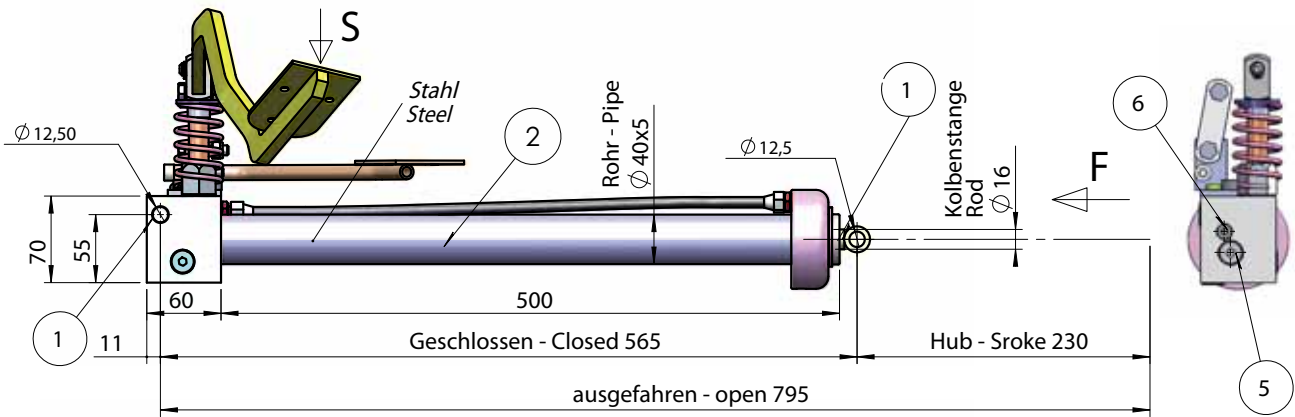

Zugzylinder (Ausfahren durch Feder) -  
Traction cylinder (with output spring)

- 1 Befestigungsbohrungen - Mounting Holes
- 2 Tank verzinkt - Zinc-coated tank
- 3 Pumppedal - Foot Pedal Lever
- 4 Ablasspedal - Release foot-pedal
- 5 Öl-Einfüllstopfen (ohne Entlüftung) -  
Filler Plug (without breather)
- 6 Ablassdrossel - Release Throttle

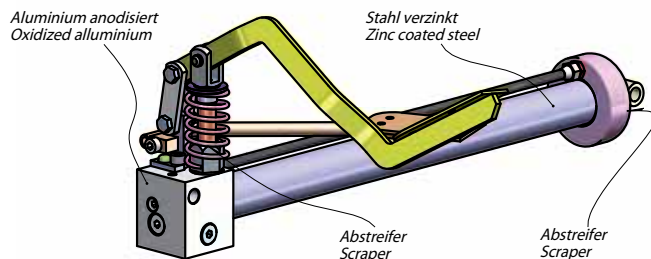

TYP TYPE	Hub B Stroke B [mm]	Förderleistung Displacement [cm <sup>3</sup> ]	Hub pro Pumpzyklus Stroke Cycle [mm]	Hubkraft F Force F [N]	Tank [L]	Gewicht Weight [kg]
GL239-HAL	230	7	10	8000	0,15	~6

Unverbindliche Angaben. Änderungen vorbehalten. - Dimensions not binding. Modifications reserved without prior notice.  
Property of HANSA-TMP SRL. Copying without authorisation will be persecuted by Law.  
Eigentum von HANSA-TMP SRL. Nicht genehmigtes Kopieren wird strafrechtlich verfolgt.



### Pumpe Typ GL243-C - Pump Type GL243-C

Einfach-Hub, mit integriertem einfachwirkenden Zylinder  
Single acting function with built-in single acting cylinder  
**ATEX II 2 GD c IIB T6 T85°C**

- 1 Ablasshandrad - Release Handknob
- 2 Öl-Einfüllstopfen - Filler Plug
- 3 Ablassdrossel - Release Throttle
- 4 Pumphebel (nicht inbegriffen) - Lever (not supplied)
- 4a-4b Hebelansatz - Lever Pin
- 6 Befestigungsbohrungen - Mounting Holes
- 7 Druckbegrenzungsventil - Relief Valve

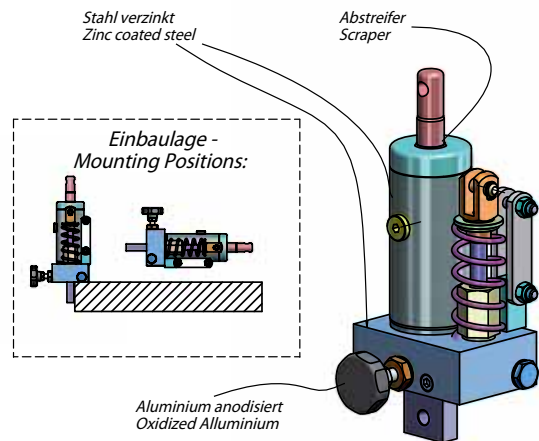
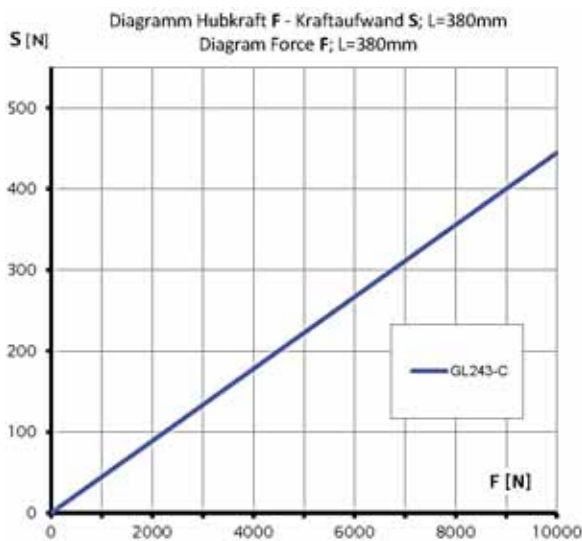
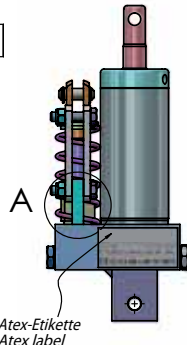
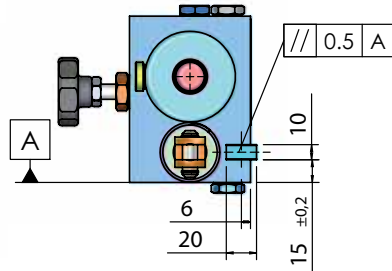
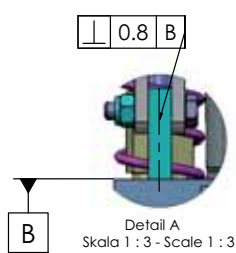
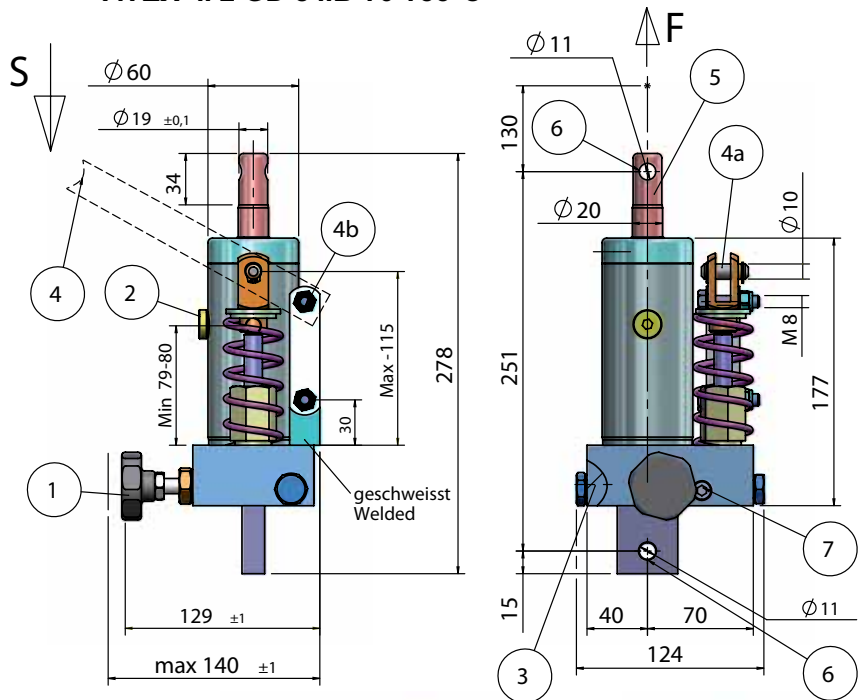
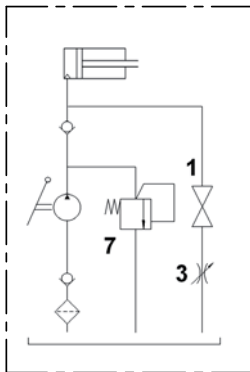

TYP TYPE	Hub B Stroke B [mm]	Förderleistung Displacement [cm <sup>3</sup> ]	Hub pro Pumpzyklus Stroke Cycle [mm]	Hubkraft F Force F [N]	Tank [L]	Gewicht Weight [kg]
GL243-C	130	3,6	~10	max 9000	0,19	6

Unverbindliche Angaben. Änderungen vorbehalten. - Dimensions not binding. Modifications reserved without prior notice.  
Property of HANSA-TMP SRL. Copying without authorisation will be persecuted by Law.  
Eigentum von HANSA-TMP SRL. Nicht genehmigtes Kopieren wird strafrechtlich verfolgt.

### Pumpe Typ GL247 - Pump Type GL247

Einfachwirkend, mit integriertem einfachwirkenden Zylinder mit Federrückzug  
Single acting function with built-in single acting cylinder with spring return

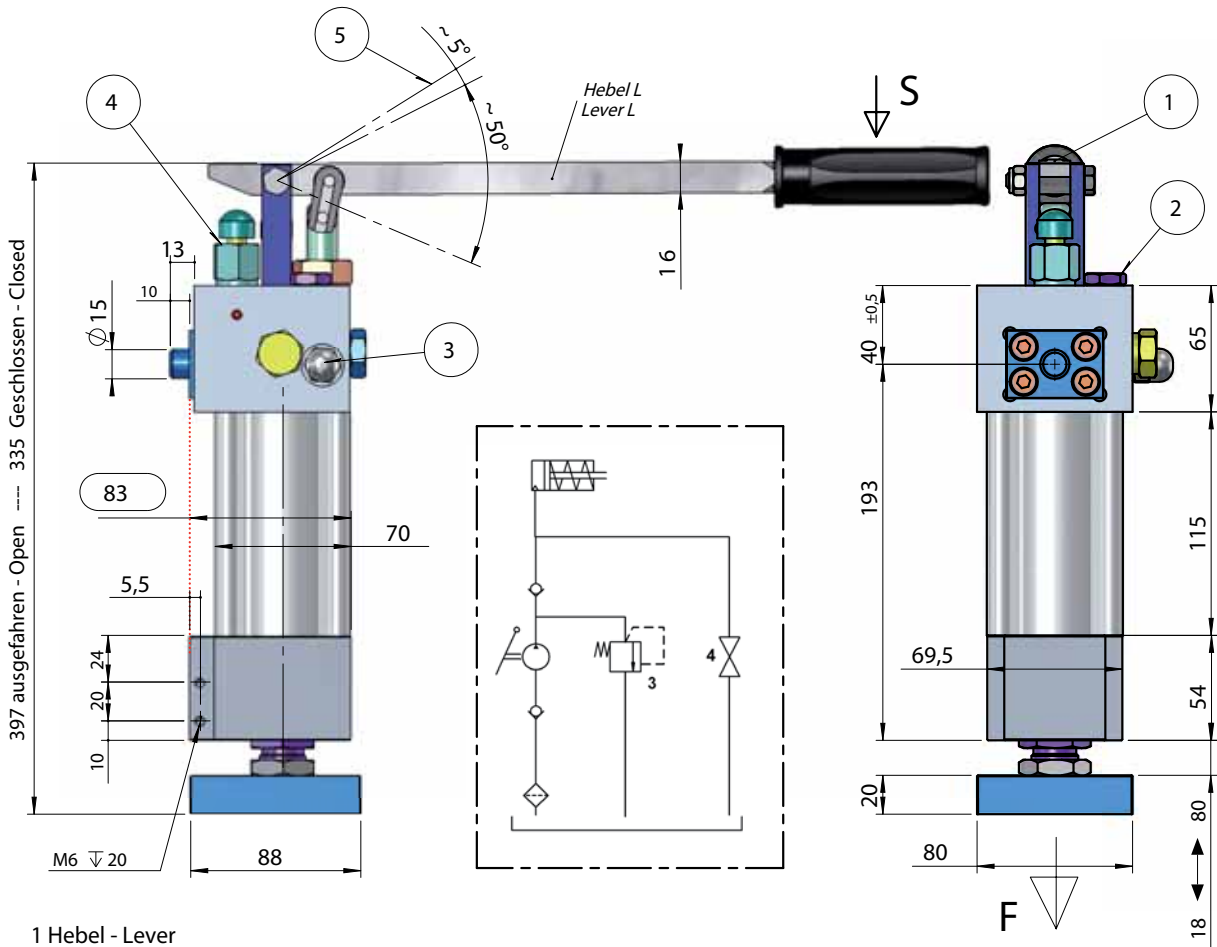

- 1 Hebel - Lever
- 2 Öl-Einfüllstopfen - Filler Plug
- 3 Max-Druckeinstellung - Relief Valve Setting
- 4 Ablassventil - Release Valve

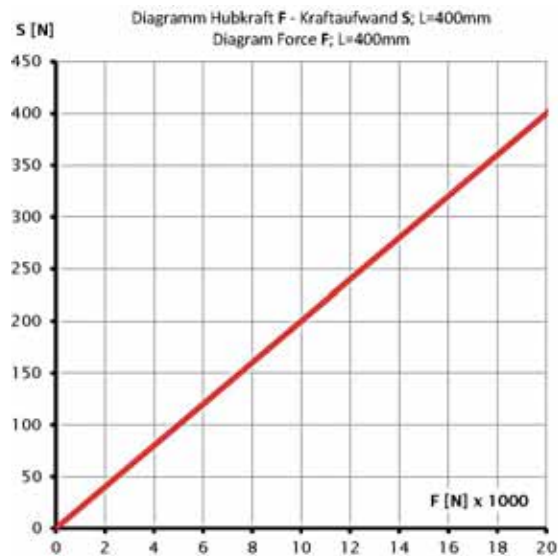
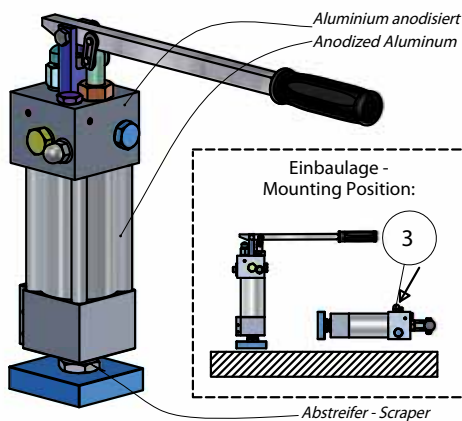

TYP TYPE	Hub Stroke [mm]	Förderleistung Displacement [cm <sup>3</sup> ]	Hub pro Pumpzyklus Stroke Cycle [mm]	Hubkraft F Force F [N]	Tank [L]	Gewicht Weight [kg]
GL247	62	5	5	20000	0,13	5

Unverbindliche Angaben. Änderungen vorbehalten. - Dimensions not binding. Modifications reserved without prior notice.  
Property of HANSA-TMP SRL. Copying without authorisation will be persecuted by Law.  
Eigentum von HANSA-TMP SRL. Nicht genehmigtes Kopieren wird strafrechtlich verfolgt.

### Pumpe Typ GL249-RG - Pump Type GL249-RG

Einfach-Hub, mit integriertem einfachwirkenden Zylinder  
Single acting function with built-in single acting cylinder

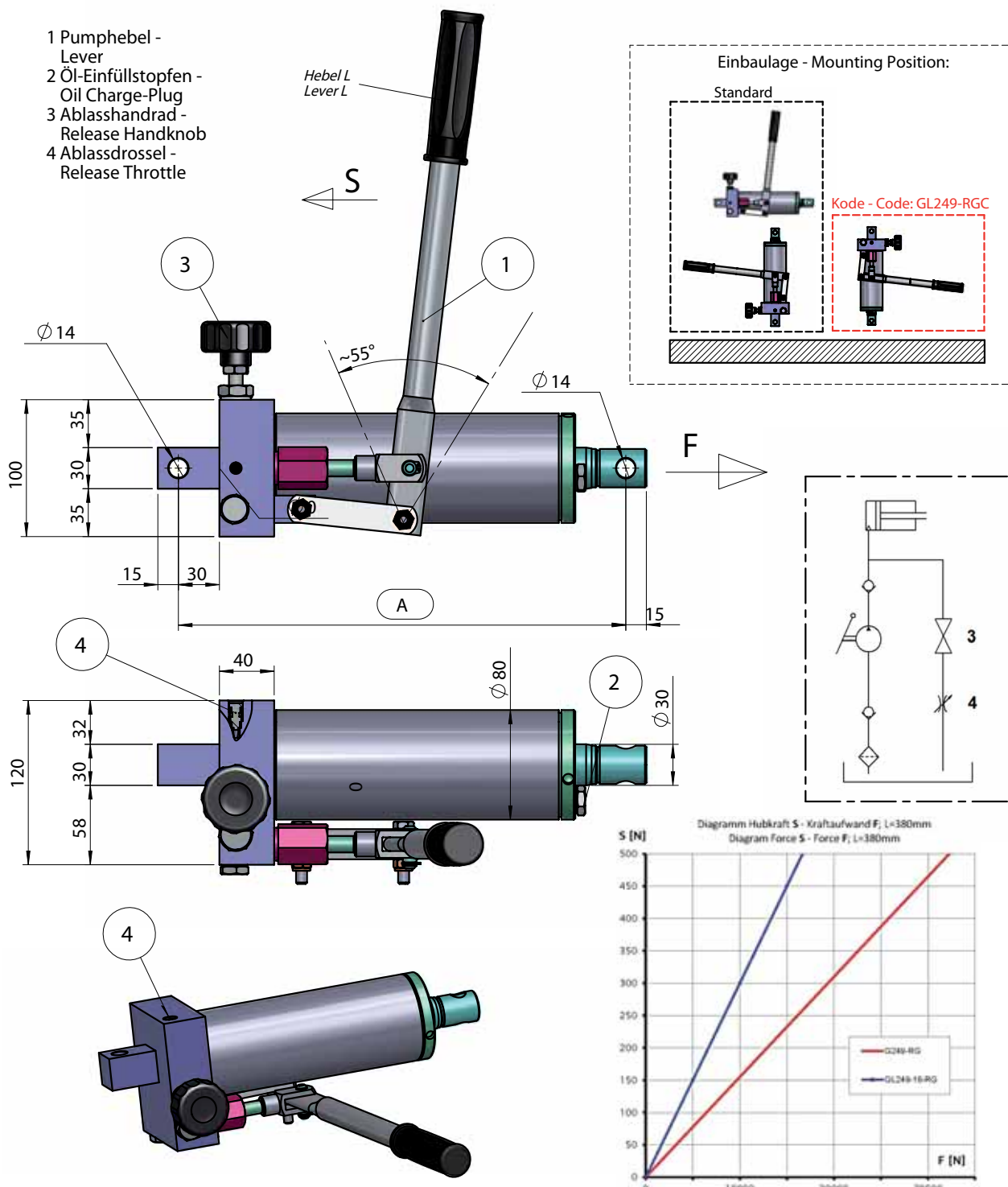

TYP TYPE	Hub B Stroke B [mm]	Förderleistung Displacement [cm <sup>3</sup> ]	Hub pro Pumpzyklus Stroke Cycle [mm]	Hubkraft F Force F [N]	A [mm]	Tank [L]	Gewicht Weight [kg]
GL249-RG	200	3,7	5	21000	327	0,42	~11
GL249-RGC	200	3,7	5	21000	327	0,42	~11
GL249-16-RG-100	100	6,7	9	15000	227	0,21	~8

Unverbindliche Angaben. Änderungen vorbehalten. - Dimensions not binding. Modifications reserved without prior notice.  
Property of HANSA-TMP SRL. Copying without authorisation will be persecuted by Law.  
Eigentum von HANSA-TMP SRL. Nicht genehmigtes Kopieren wird strafrechtlich verfolgt.

### Pumpe Typ GL254AL - Pump Type GL254AL

*Doppelhub-Funktion mit integriertem einfachwirkenden Zylinder*  
*Double-stroke function with built-in single acting cylinder*

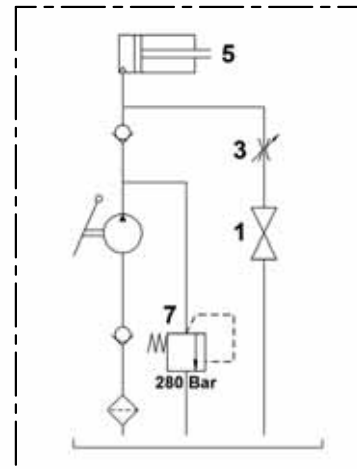
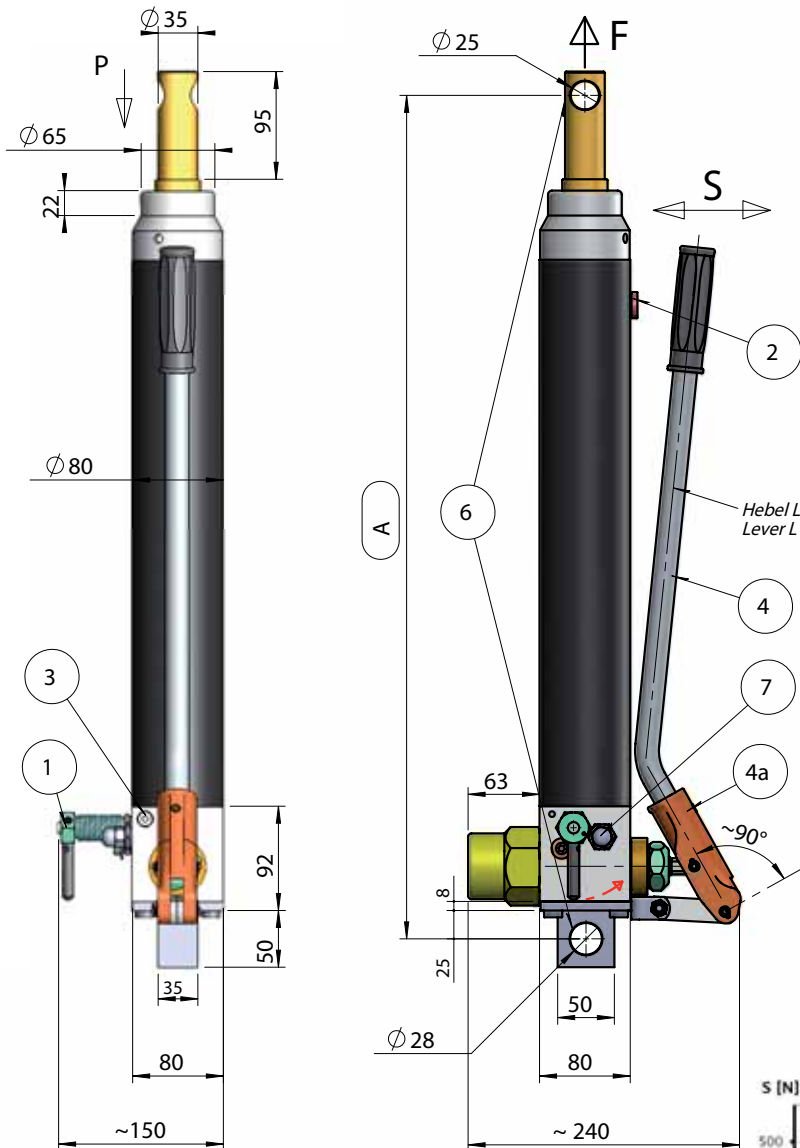

- 1 Ablassventil (normal geschlossen) \*\* - Release Handknob (normally closed) \*\*
- 2 Öleinfüllstopfen - Filler Plug
- 3 Ablassdrossel - Release Throttle
- 4 Hebelstange - Lever Extension
- 4a Pumpehebel - Lever
- 5 Kolbenstange - Cylinder Rod
- 6 Befestigungsbohrungen - Mounting Holes
- 7 Druckbegrenzungsventil - Relief Valve

\*\* Ventilsitz gehärtet und geschliffen  
\*\* Hardened and Polished Valve

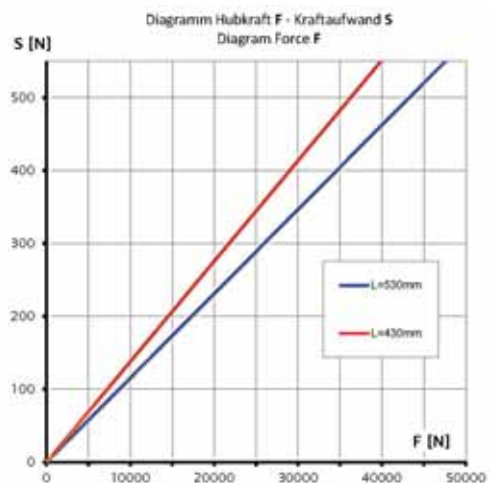
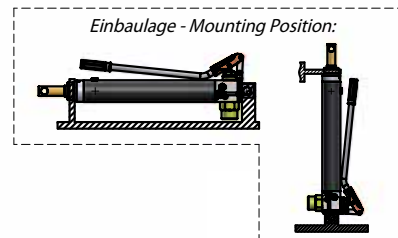

TYP TYPE	Hub B Stroke B [mm]	Förderleistung Displacement [cm <sup>3</sup> ]	Hub pro Pumpzyklus Stroke Cycle [mm]	Hubkraft F Force F [N]	A [mm]	L [mm]	Tank [L]	Gewicht Weight [kg]
GL254AL	450	21	12	45000	745	530	1	~18

Unverbindliche Angaben. Änderungen vorbehalten. - Dimensions not binding. Modifications reserved without prior notice.  
Property of HANSA-TMP SRL. Copying without authorisation will be persecuted by Law.  
Eigentum von HANSA-TMP SRL. Nicht genehmigtes Kopieren wird strafrechtlich verfolgt.

### Pumpe Typ GL267 - Pump Type GL267

Einfach-Hub, mit integriertem einfachwirkenden Zylinder  
Single acting function with built-in single acting cylinder

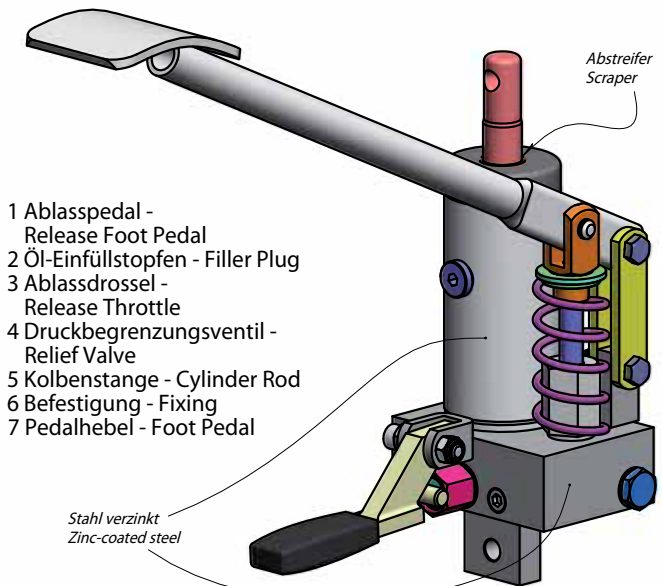
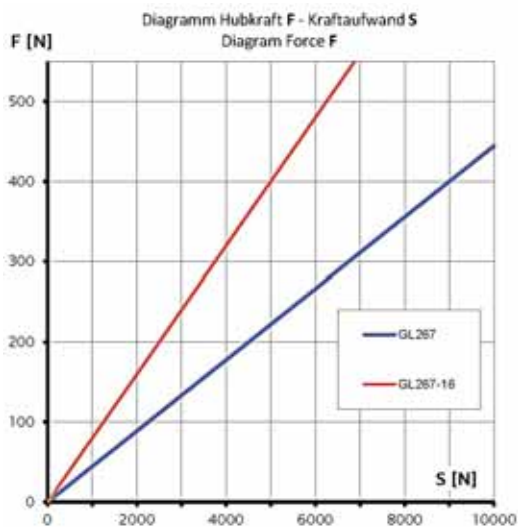
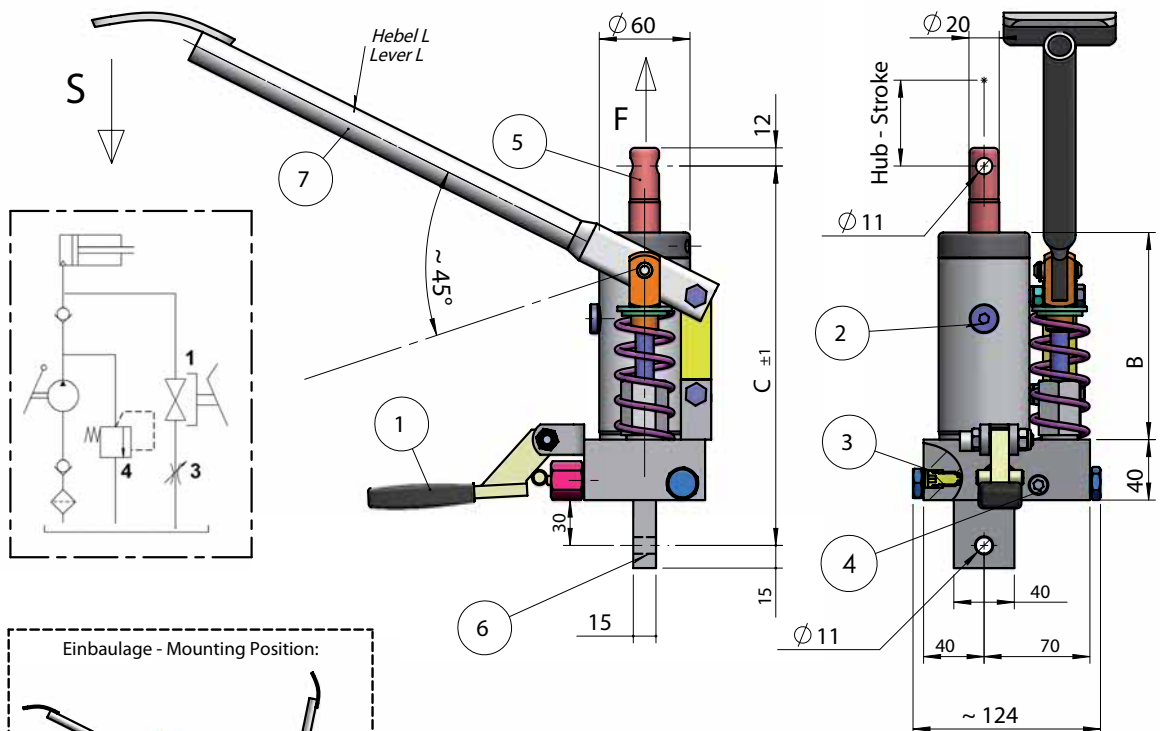

\* Bitte gewünschten Hub angeben - Mention requested stroke

TYP TYPE	Hub Stroke [mm]	Förderleistung Displacement [cm <sup>3</sup> ]	Hub pro Pumpzyklus Stroke Cycle [mm]	Hubkraft F Force F [N]	B [mm]	C [mm]	Tank [L]	Gewicht Weight [kg]
GL267	130	3,6	~10	max 9000	137	253	0,18	6
*GL267-xxx	xxx	3,6	~10	max 9000	xxx + 7	xxx + 123	-	-
GL267-12	130	6,6	~20	max 5000	137	253	0,18	6
*GL267-16-xxx	xxx	6,6	~20	max 5000	xxx + 7	xxx + 123	-	-

Unverbindliche Angaben. Änderungen vorbehalten. - Dimensions not binding. Modifications reserved without prior notice.  
Property of HANSA-TMP SRL. Copying without authorisation will be persecuted by Law.  
Eigentum von HANSA-TMP SRL. Nicht genehmigtes Kopieren wird strafrechtlich verfolgt.

### Pumpe Typ GL299-HAL - Pump Type GL299-HAL

*Doppelhub-Funktion mit doppeltwirkendem Differentialzylinder*  
*Double acting function with built-in double acting differential cylinder*

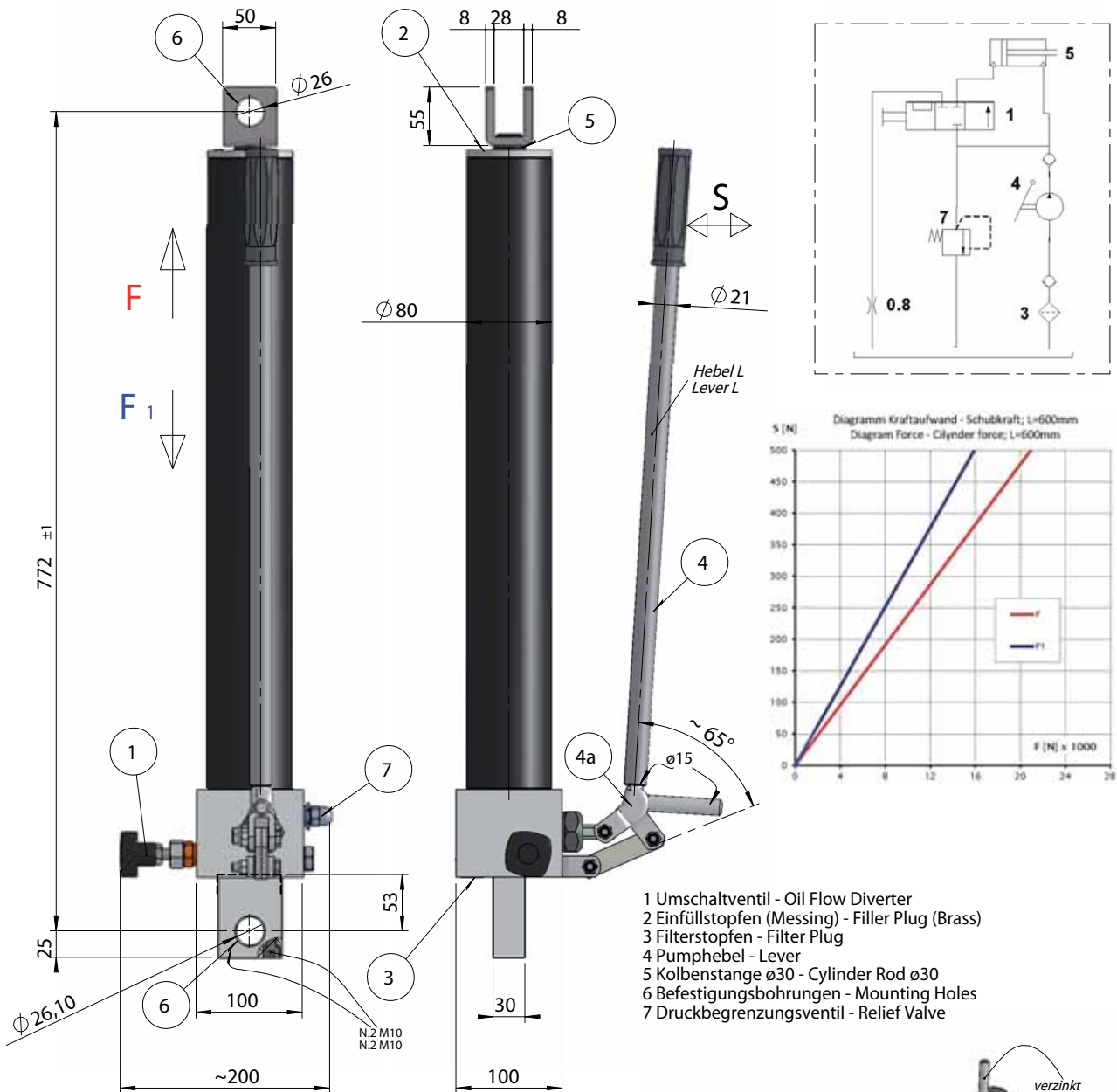

- 1 Umschaltventil - Oil Flow Diverter
- 2 Einfüllstopfen (Messing) - Filler Plug (Brass)
- 3 Filterstopfen - Filter Plug
- 4 Pumphebel - Lever
- 5 Kolbenstange ø30 - Cylinder Rod ø30
- 6 Befestigungsbohrungen - Mounting Holes
- 7 Druckbegrenzungsventil - Relief Valve

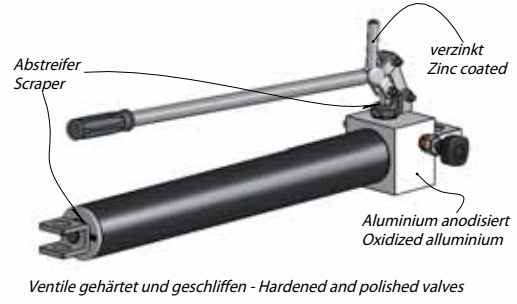
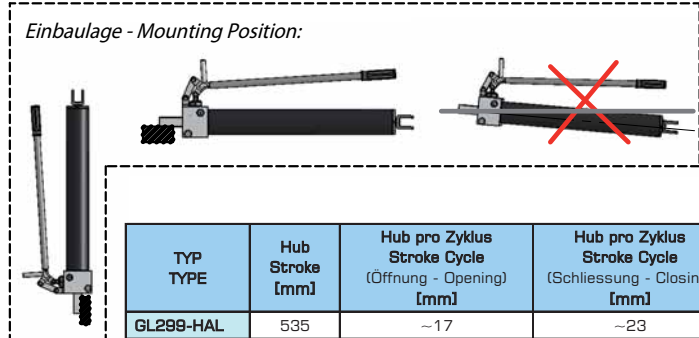

TYP TYPE	Hub Stroke [mm]	Hub pro Zyklus Stroke Cycle (Öffnung - Opening) [mm]	Hub pro Zyklus Stroke Cycle (Schliessung - Closing) [mm]	Zugkraft F1 Force F1 [N]	Schubkraft F Force F [N]	Betriebstemperatur Working temperature [C°]	Gewicht Weight [kg]
GL299-HAL	535	~17	~23	14000	18000	-30 / +60	18

*Unverbindliche Angaben. Änderungen vorbehalten. - Dimensions not binding. Modifications reserved without prior notice.*  
*Property of HANSA-TMP SRL. Copying without authorisation will be persecuted by Law.*  
*Eigentum von HANSA-TMP SRL. Nicht genehmigtes Kopieren wird strafrechtlich verfolgt.*

### Pumpe Typ GL304 - Pump Type GL304

*Doppelhub-Funktion mit integriertem einfachwirkenden Zylinder*  
*Double-acting function with built-in single acting cylinder*

- 1 Ablassventil - Release Handknob
- 2 Öl-Einfüllstopfen - Filler Plug
- 3 Ablassdrossel - Release Throttle
- 4 Pumpehebel - Lever
- 5 Kolbenstange - Piston Rod
- 6 Befestigungsbohrungen - Mounting Holes
- 7 Druckbegrenzungsventil - Relief Valve

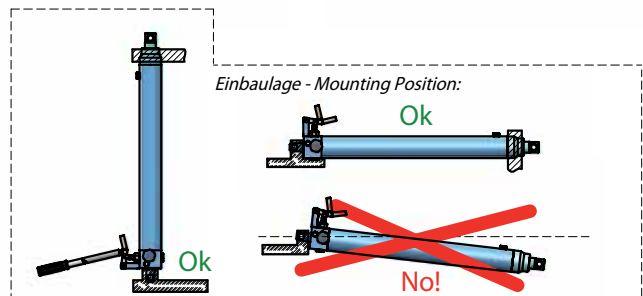
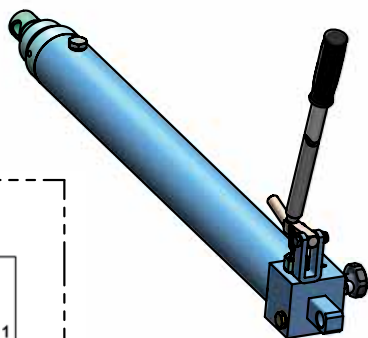
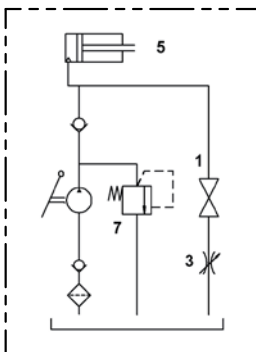
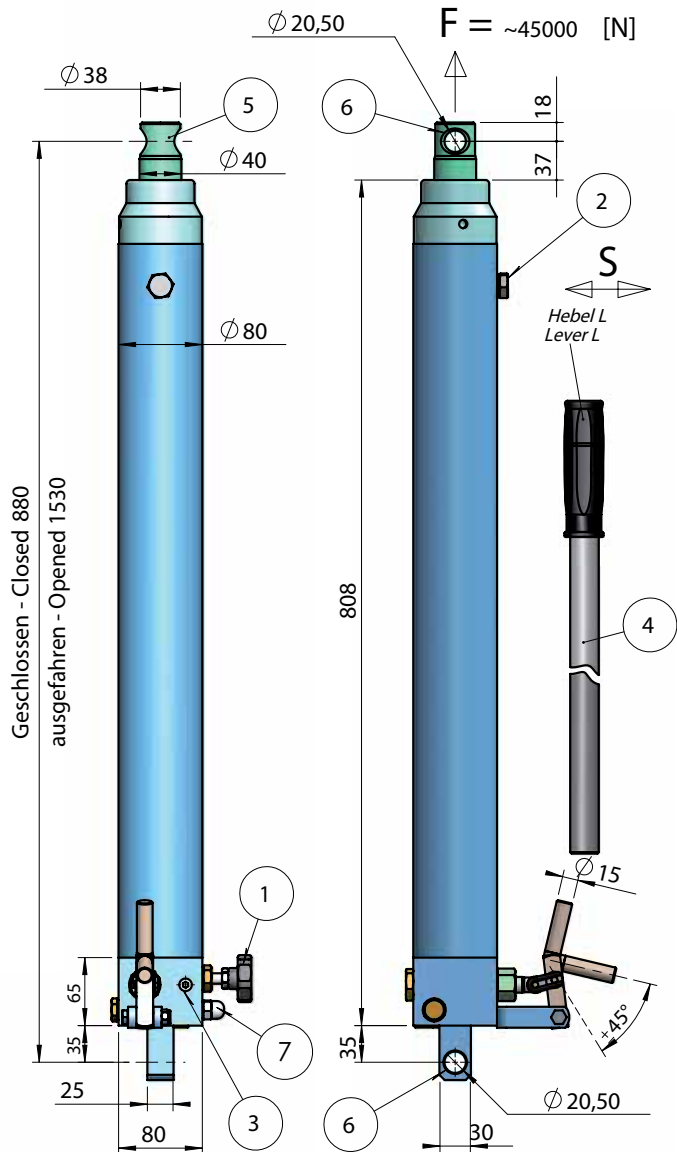
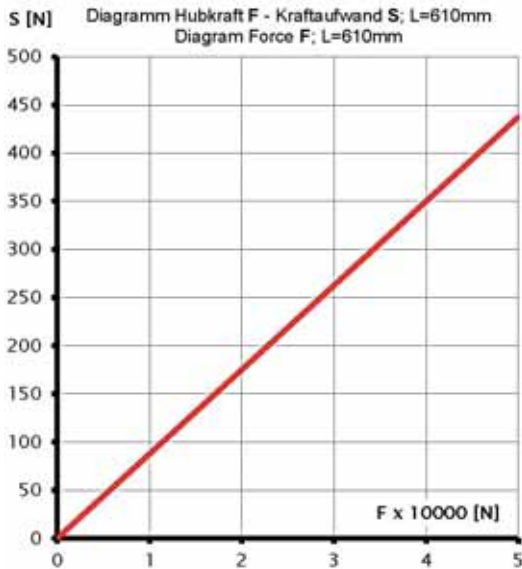

TYP TYPE	Hub Stroke [mm]	Förderleistung Displacement [cm <sup>3</sup> ]	Hub pro Pumpzyklus Stroke Cycle [mm]	Hubkraft F Force F [N]	Gewicht Weight [kg]
GL304	650	9	6	45000	22

*Unverbindliche Angaben. Änderungen vorbehalten. - Dimensions not binding. Modifications reserved without prior notice.*  
*Property of HANSA-TMP SRL. Copying without authorisation will be persecuted by Law.*  
*Eigentum von HANSA-TMP SRL. Nicht genehmigtes Kopieren wird strafrechtlich verfolgt.*

### Pumpe Typ GLDE 25-ICN - Pump Type GLDE 25-ICN

Mit Umschaltventil und doppelwirkendem Differentialzylinder  
With diverter valve and double acting differential cylinder

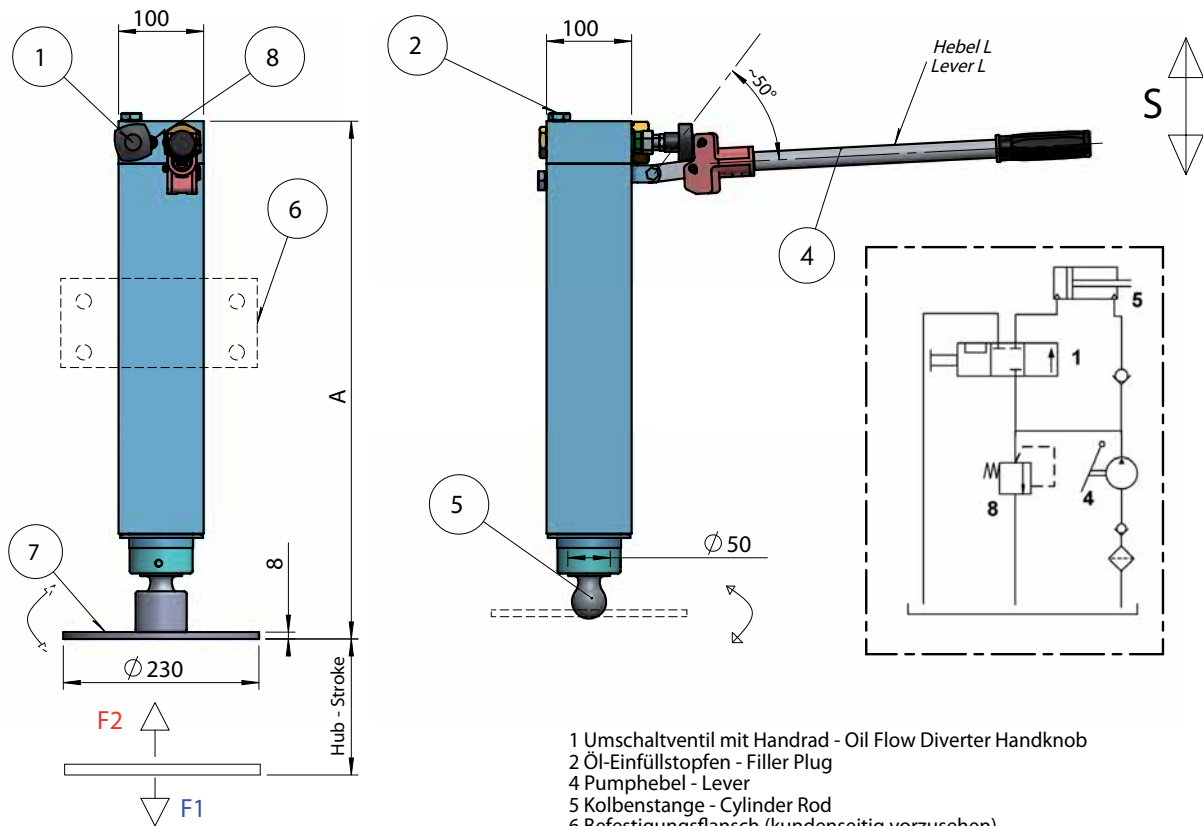

- 1 Umschaltventil mit Handrad - Oil Flow Diverter Handknob
- 2 Öl-Einfüllstopfen - Filler Plug
- 4 Pumpebel - Lever
- 5 Kolbenstange - Cylinder Rod
- 6 Befestigungsflansch (kundenseitig vorzusehen) - Flange for Support (to be provided by the customer)
- 7 Schwenkbare Flanschauflage - Adjustable Flange for Support
- 8 Druckbegrenzungsventil - Max. Pressure Valve

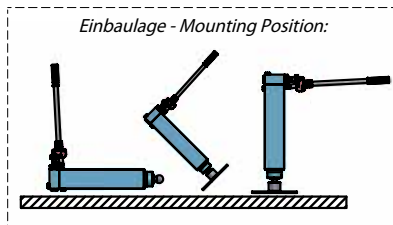

Auf Wunsch für senkrechten Hebel möglich  
Available on request for vertical lever

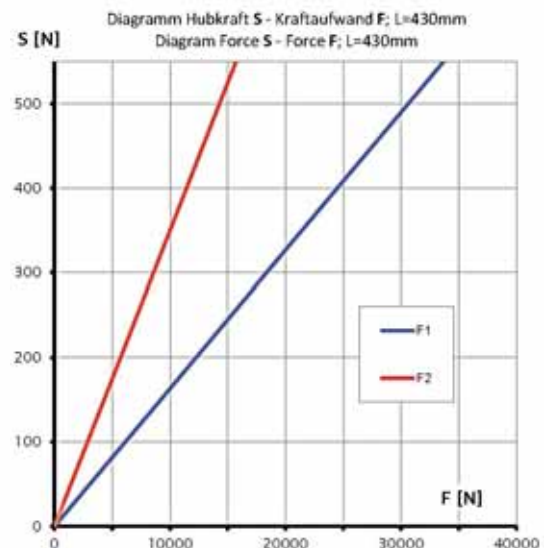

TYP TYPE	Hub Stroke [mm]	Förderleistung Displacement [cm <sup>3</sup> ]	Hub pro Pumpzyklus Stroke Cycle [mm]	Hubkraft F1/F2 Force F1/F2 [N]	A [mm]	Tank [L]	Gewicht Weight [kg]
GLDE25-ICN	380	15,5	~7,5	30000 / 1000	600	0,8	29
GLDE25-ICN-500	500	15,5	~7,5	30000 / 1000	720	1,1	34

Unverbindliche Angaben. Änderungen vorbehalten. - Dimensions not binding. Modifications reserved without prior notice.  
Property of HANSA-TMP SRL. Copying without authorisation will be persecuted by Law.  
Eigentum von HANSA-TMP SRL. Nicht genehmigtes Kopieren wird strafrechtlich verfolgt.



### Pumpe Typ GLOP 6-8-10 - Pump Type GLOP 6-8-10

Druckluftbetriebene Hydraulikpumpe mit einem Pumpkolben  
Air-Hydraulic pump with one pumping piston

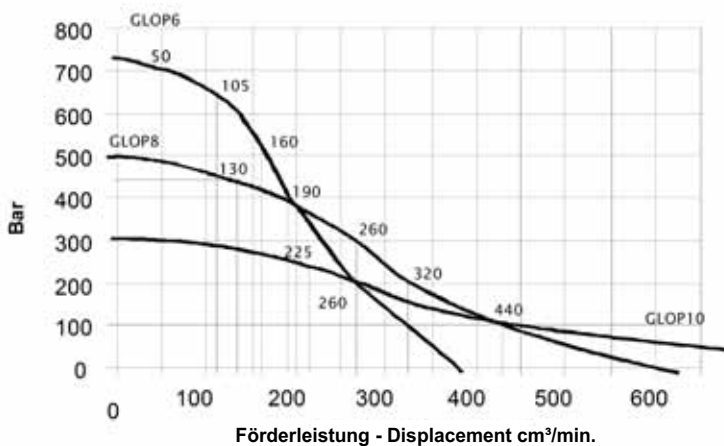
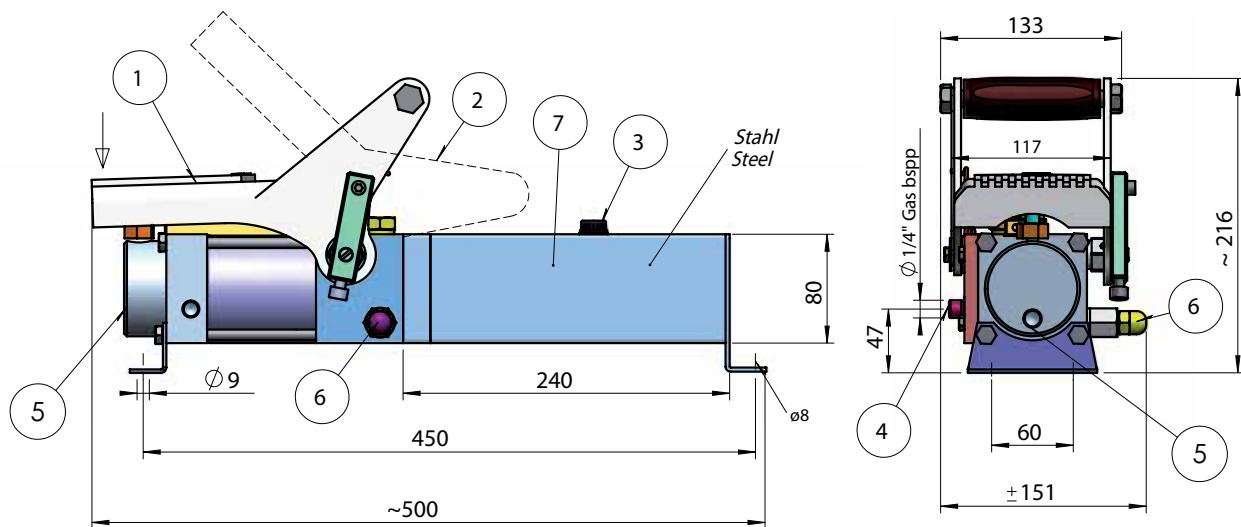

Gewicht - Weight Kg. ~9

- 1 Pumpenbetätigung - Pump Operation
- 2 Ölablass - Oil Discharge
- 3 Öl-Einfüllstopfen - Filler Plug
- 4 Druckanschluss 1/4" Gas bspp - Pressure Port 1/4" Gas bspp
- 5 Druckluftanschluss 1/4" Gas bspp - Air Inlet 1/4" Gas bspp
- 6 Max-Druckeinstellung - Pressure Relief Setting
- 7 Tank 1,3 l

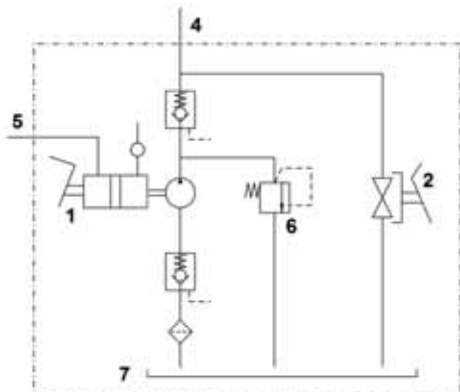
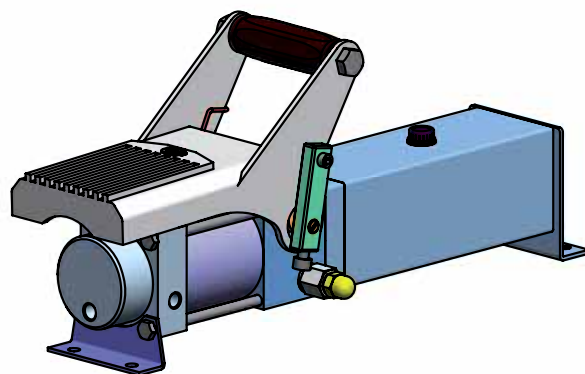
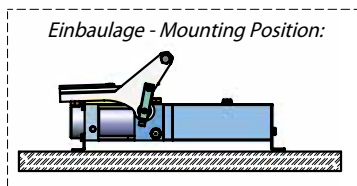

TYP TYPE	Fördervolumen Displacement [cm³/min]	Druck Pressure [bar]	Druckluftbedarf Air Consumption [l/min]
GLOP6	~350	700	~50
GLOP8	~600	500	~45
GLOP10	~900	300	~43

Unverbindliche Angaben. Änderungen vorbehalten. - Dimensions not binding. Modifications reserved without prior notice.  
Property of HANSA-TMP SRL. Copying without authorisation will be persecuted by Law.  
Eigentum von HANSA-TMP SRL. Nicht genehmigtes Kopieren wird strafrechtlich verfolgt.

### Pumpe Typ GLOP 625-725 - Pump Type GLOP 625-725

Druckluftbetriebene Hydraulikpumpe mit Koaxial-Doppelkolben  
Air-Hydraulic Pump with co-axial piston system

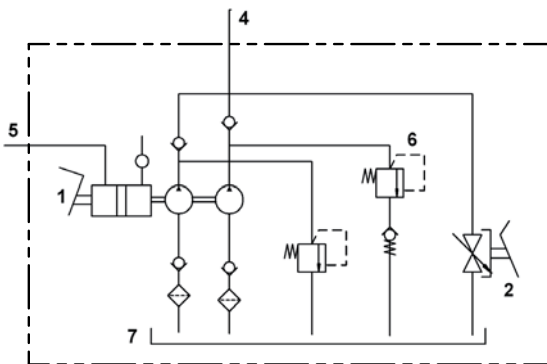
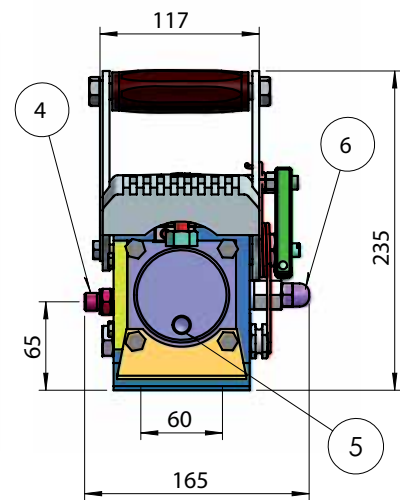
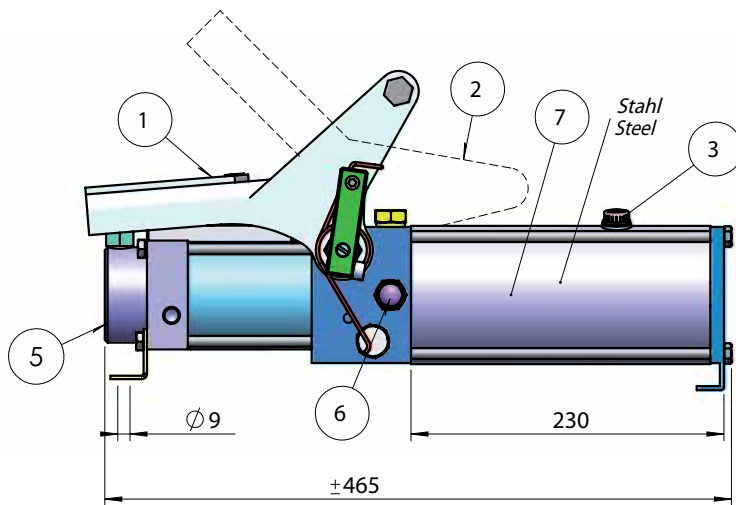

Einbaulage - Mounting Position:

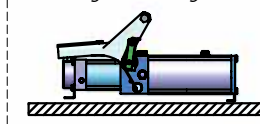

Gewicht (mit Ölfüllung) - Weight (with oil) Kg. ~14,3

- 1 Pumpenbetätigung - Pump Operation
- 2 Ölablass - Oil Discharge
- 3 Öl-Einfüllstopfen - Filler Plug
- 4 Druckanschluss (1/4" Gas bspp) - Pressure Port (1/4" Gas bspp)
- 5 Druckluftanschluss (1/4" Gas bspp) - Air Inlet (1/4" Gas bspp)
- 6 Max-Druckeinstellung - Relief Valve
- 7 Tank 1,2l

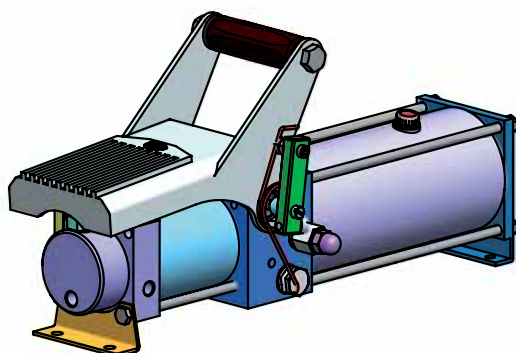
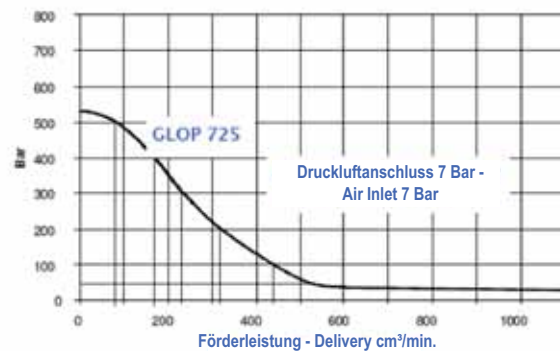
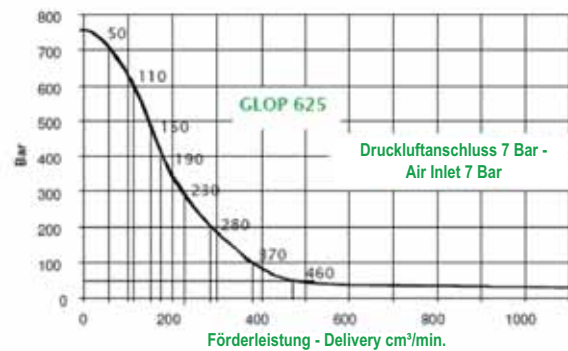

TYP TYPE	Druckanschluss cm <sup>3</sup> /min. Pressure Port cm <sup>3</sup> /min.				Druck Pressure	Druckluftbedarf l/min. Air Consumption l/min.
	0 bar Öldruck 0 bar Oil	10 bar Öldruck 10 bar Oil	20 bar Öldruck 20 bar Oil	30 bar Öldruck 30 bar Oil		
GLOP625	4000	3000	2500	2000	10 bar Druckluft 10 bar Air	43
GLOP725	4300	3200	2700	2200	700 Bar	43

Unverbindliche Angaben. Änderungen vorbehalten. - Dimensions not binding. Modifications reserved without prior notice.  
Property of HANSA-TMP SRL. Copying without authorisation will be persecuted by Law.  
Eigentum von HANSA-TMP SRL. Nicht genehmigtes Kopieren wird strafrechtlich verfolgt.

### 4-Wege Umschaltventil GL4VN - 4 Way Diverter Group GL4VN

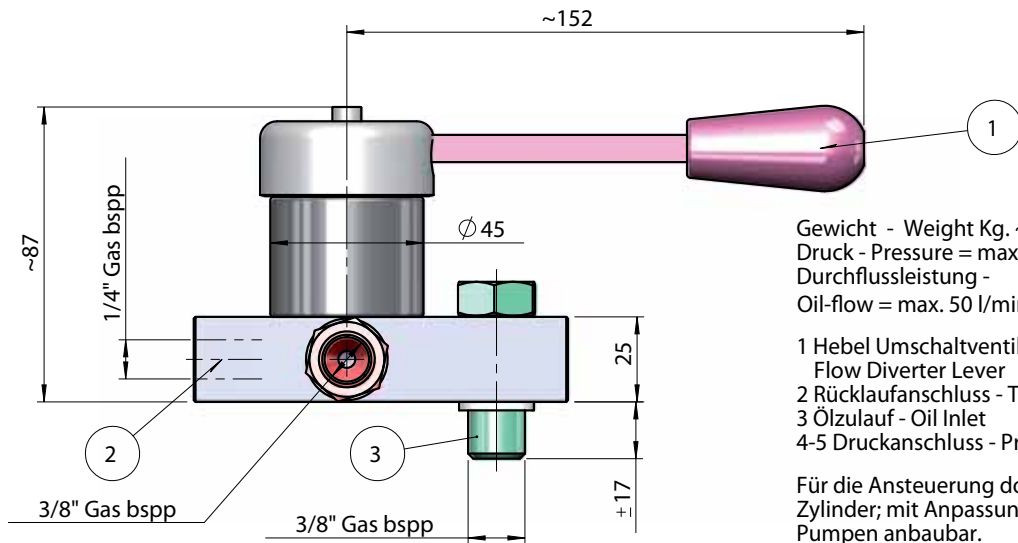

Gewicht - Weight Kg. ~1,0  
 Druck - Pressure = max. 700 bar  
 Durchflussleistung -  
 Oil-flow = max. 50 l/min.

- 1 Hebel Umschaltventil -  
Flow Diverter Lever
- 2 Rücklaufanschluss - Tank Port
- 3 Ölzulauf - Oil Inlet
- 4-5 Druckanschluss - Pressure Port

Für die Ansteuerung doppeltwirkender Zylinder; mit Anpassungen an fast alle Pumpen anbaubar.

4-Way-diverter valve for the control of double acting cylinders; with modifications available for nearly all pump models.

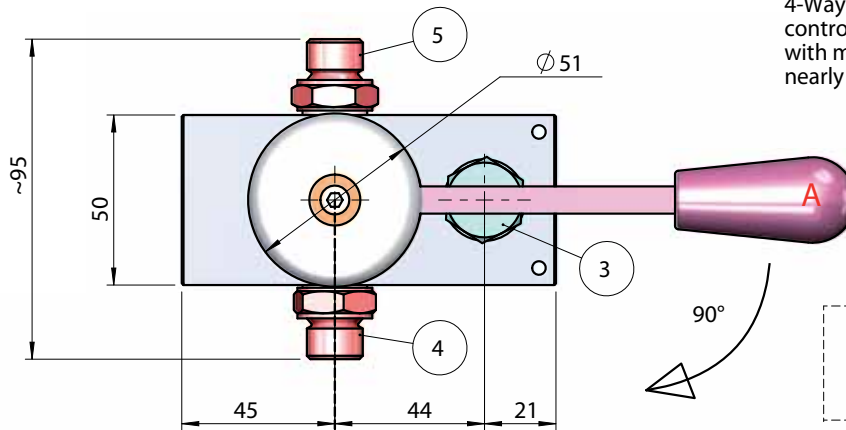

*Einbaulage - Mounting:  
uneingeschränkt.  
Any Position.*

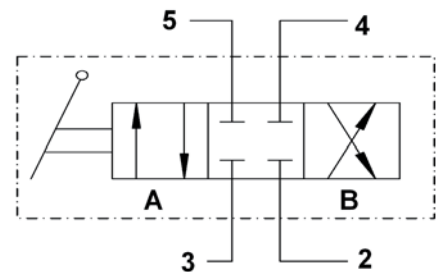
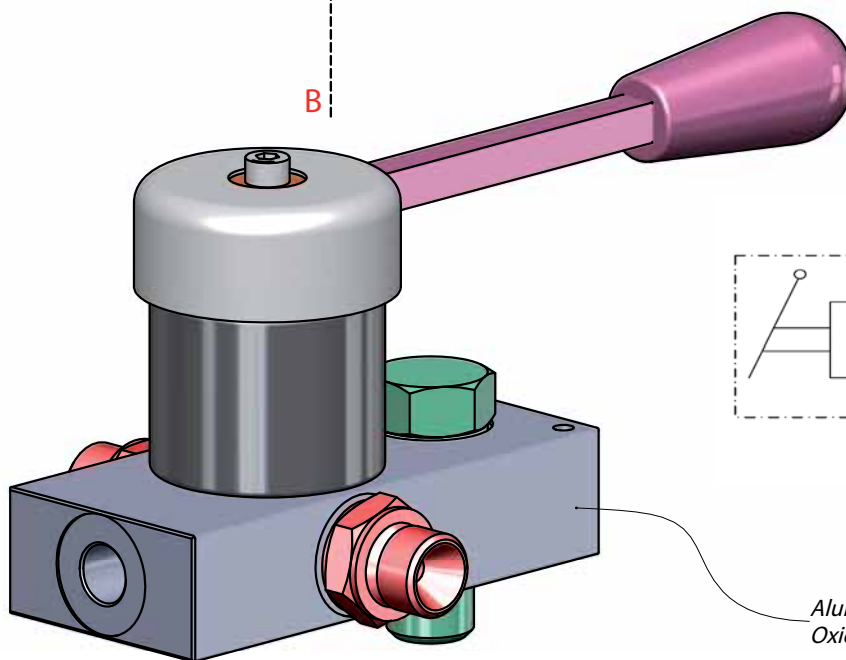

Aluminium anodisiert  
Oxidized Aluminium

Unverbindliche Angaben. Änderungen vorbehalten. - Dimensions not binding. Modifications reserved without prior notice.  
 Property of HANSA-TMP SRL. Copying without authorisation will be persecuted by Law.  
 Eigentum von HANSA-TMP SRL. Nicht genehmigtes Kopieren wird strafrechtlich verfolgt.

### Zusatzbauteile - Accessories

#### Ablassventil mit Druckbegrenzungsventil RVM Ball-Valve with Relief Valve Series RVM

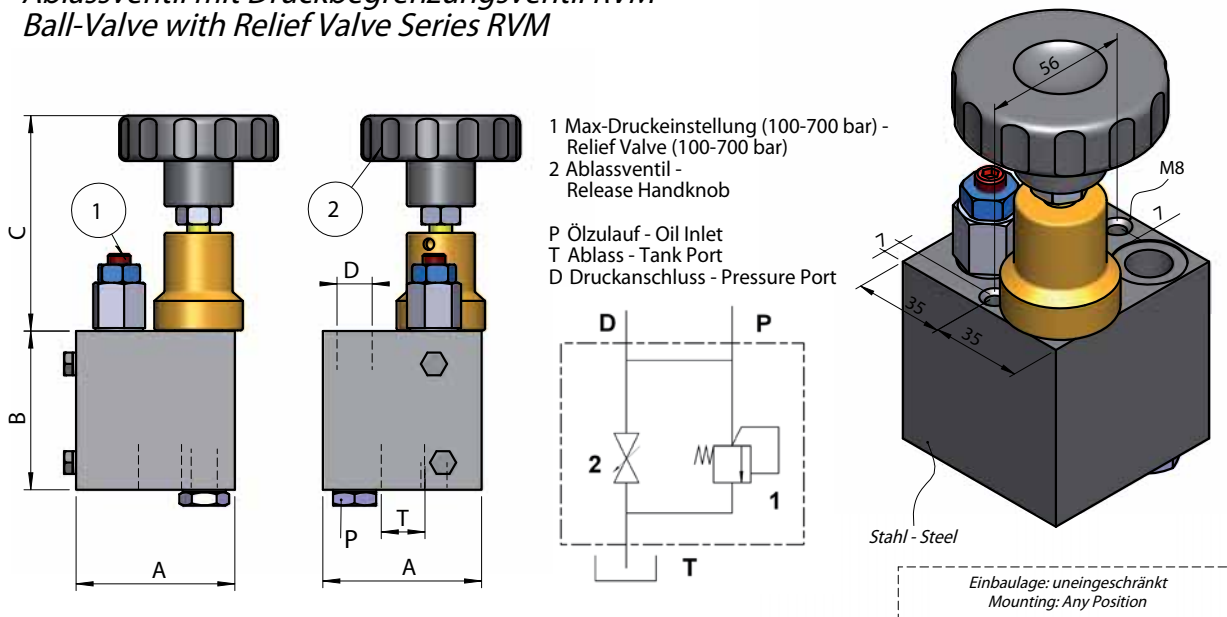

Typ-Type	Bar	A	B	C	D	P	T	Gewicht-Weight [Kg]
RVM 38	700	70	70	115	3/8" Gas bspp	3/8" Gas bspp	1/2" Gas bspp	~2,8

EINSATZ: Dank der beschränkten Abmessungen erfolgt der Einsatz bevorzugt auf Hydraulikaggregaten.  
KONSTRUKTIONSMERKMALE: Aus Stahl, feinmechanisch bearbeitet; einfache Handhabung. Es handelt sich um eine Kombination des ventils der Serie "R" mit dem Druckbegrenzungsventil der Serie VMP.

APPLICATIONS: Thanks to the reduced dimensions, this valve is specially suitable for installation on power-packs.  
FEATURES: Made in steel; easy installation; machining on most advanced facilities; easy maintenance. Combination of ball valve series "R1V" and relief valve series "VMP" maintaining the same characteristics of those.

#### Ablassventil Serie R1V Ball-Valve Series R1V

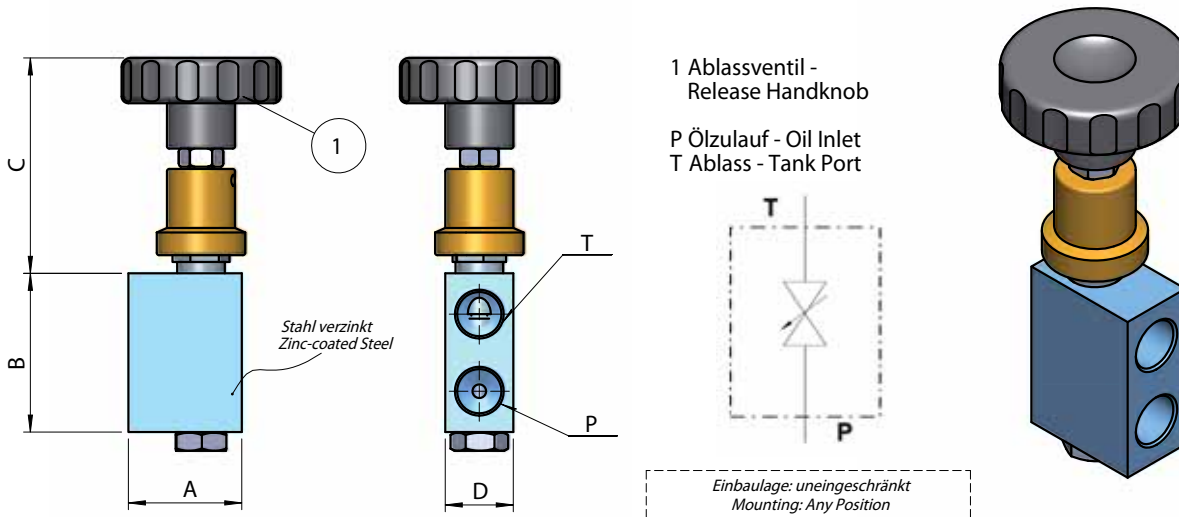

Typ-Type	Bar	A	B	C	D	P	T	Gewicht-Weight [Kg]
R1V	700	50	70	115	30	1/2" Gas bspp	1/2" Gas bspp	~1,0

EINSATZ: In Hydrauliksystemen, welche eine schnelle Druckwegschaltung benötigen, indem die Druckflüssigkeit direkt zum Tank geleitet wird, wie während der Umschaltphase von einem zu einem anderen Verbraucher.

KONSTRUKTIONSMERKMALE: Aus Stahl, feinmechanisch bearbeitet; einfache Handhabung. Keine Korrosion. Ohne Leckage für den gesamten Druckbereich.

APPLICATIONS: in hydraulic circuit with necessity of rapid pressure unloading by connecting the pressure line to the tank during passages from one operation to another, or to shut down or feed in rapidly oil into the circuit.

FEATURES: Made in steel by using most advanced manufacturing facilities; easy maintenance; corrosion proof; perfectly closing without any drain at any pressure.

Unverbindliche Angaben. Änderungen vorbehalten. - Dimensions not binding. Modifications reserved without prior notice.  
Property of HANSA-TMP SRL. Copying without authorisation will be persecuted by Law.  
Eigentum von HANSA-TMP SRL. Nicht genehmigtes Kopieren wird strafrechtlich verfolgt.

### Zusatzbauteile - Accessories

#### Druckbegrenzungsventil VMP Pressure Relief Valve Series VMP

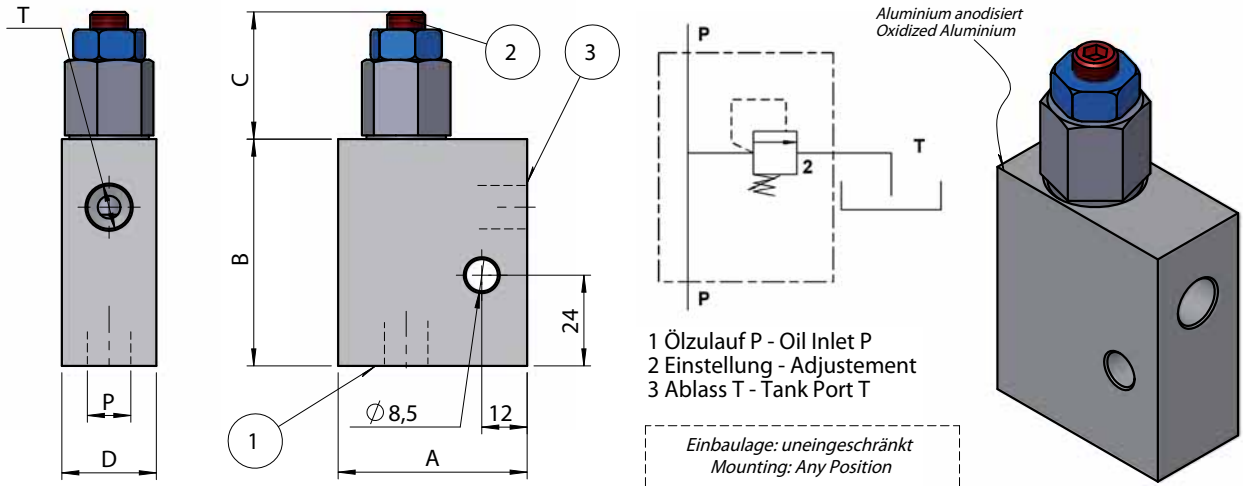

**EINSATZ:** Zur Vermeidung von Druckspitzen, welche die Bauteile des Hydrauliksystems beschädigen könnten (Pumpen, Manometer, Motore usw.)  
**KONSTRUKTIONSMERKMALE:** Mit Alluminiumgehäuse, feinmechanisch bearbeitet; einfache Handhabung. Keine Korrosion. Mittels Feder einstellbar für Drücke zwischen 5 und 700 Bar.

**APPLICATIONS:** The VMP valves avoid that peak-pressures can damage components of the hydraulic circuit (pumps, motors, gauges, etc.).  
**FEATURES:** Made in alluminium by using most advanced manufacturing facilities; easy maintenance; corrosion proof; adjustable for pressures between 5 and 700 Bar by acting on the setting spring.

#### Abschaltventil Serie VEM Exclusion Valve Series VEM

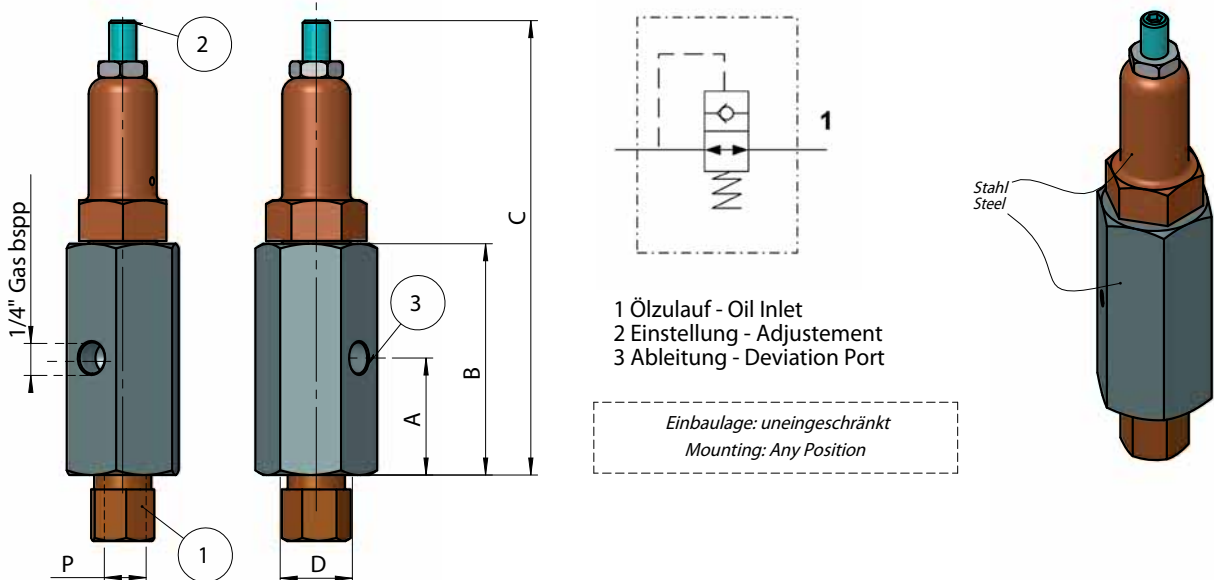

**EINSATZ:** Zum Wegschalten der Funktion von Komponenten in hydraulischen Systemen.  
**KONSTRUKTIONSMERKMALE:** aus Stahl, feinmechanisch bearbeitet; einfache Handhabung; kein Druckverlust. Druckeinstellung mittels Feder, welche mittels Schieber eine Kugel steuert, die den Öldurchfluss unterbricht. Zwecks guter Funktion muss die Druckflüssigkeit ohne Verschmutzung sein.

**APPLICATIONS:** used in circuits which need the exclusion by means of interception of the oil-flow to specific components.  
**FEATURES:** made in steel by using most advanced manufacturing facilities; easy maintenance; no pressure drop. Setting of pressure is obtained by acting on the setting spring which, by means of a piston, commands a ball which excludes the oil-flow. In order to assure good function, it is essential that the oil is without contamination.

*Unverbindliche Angaben. Änderungen vorbehalten. - Dimensions not binding. Modifications reserved without prior notice.  
 Property of HANSA-TMP SRL. Copying without authorisation will be persecuted by Law.  
 Eigentum von HANSA-TMP SRL. Nicht genehmigtes Kopieren wird strafrechtlich verfolgt.*

### Zusatzbauteile - Accessories

#### Baugruppe D - Group D

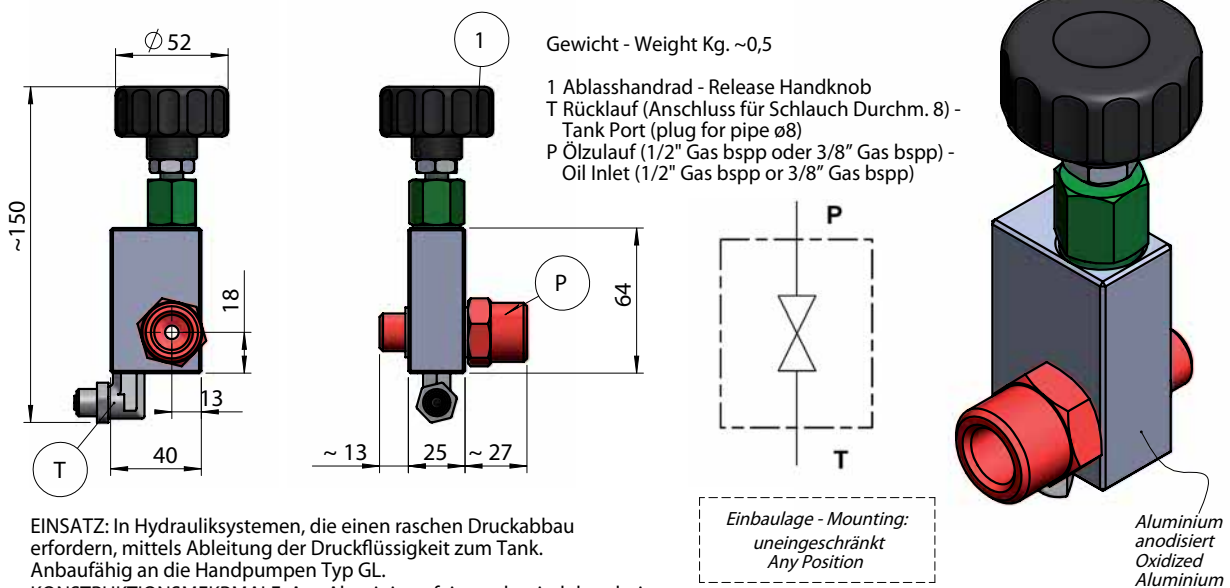

EINSATZ: In Hydrauliksystemen, die einen raschen Druckabbau erfordern, mittels Ableitung der Druckflüssigkeit zum Tank. Anbaufähig an die Handpumpen Typ GL.  
KONSTRUKTIONSMERKMALE: Aus Aluminium, feinmechanisch bearbeitet; einfache Handhabung. Korrosionssicher.

APPLICATIONS: in hydraulic circuit with necessity of rapid pressure unloading by connecting the pressure line to the tank. Available on pumps type GL.  
FEATURES: Made in aluminium by using most advanced manufacturing facilities; easy maintenance; corrosion proof.

#### Baugruppe DV - Group DV

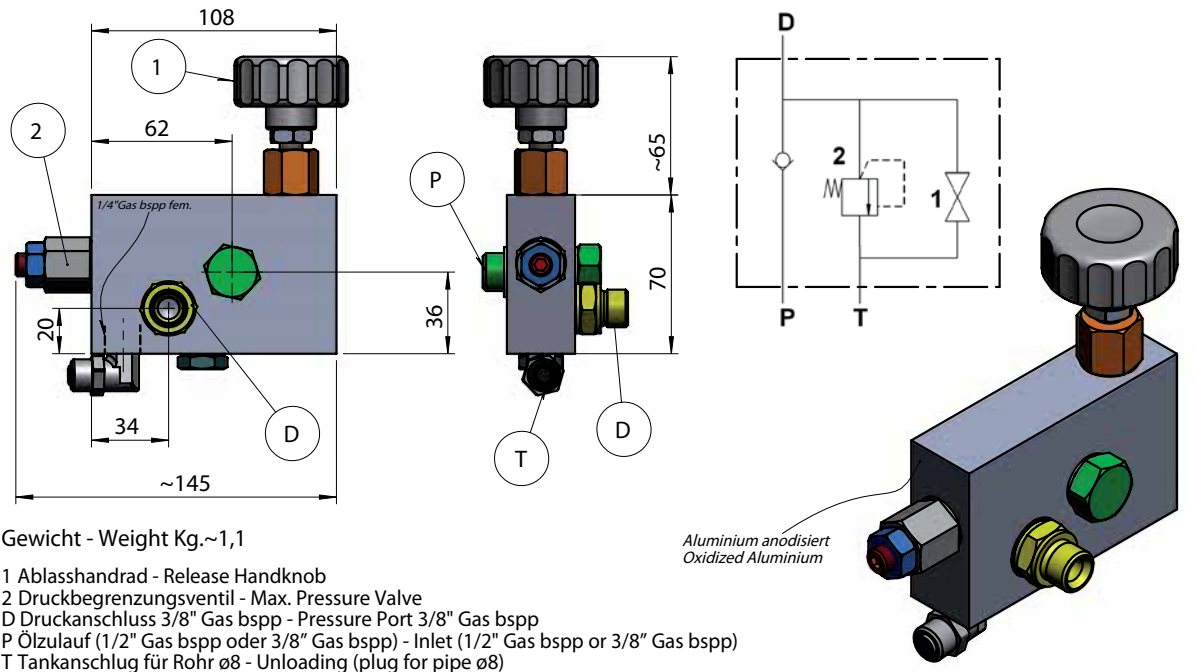

EINSATZ: In Hydrauliksystemen, welche einen raschen Druckabbau erfordern, mittels Wegschalten der Druckflüssigkeit zum Tank. Anbaufähig an die Pumpen Typ GL.  
KONSTRUKTIONSMERKMALE: Aus Aluminium, feinmechanisch bearbeitet; einfache Handhabung. Korrosionssicher.

APPLICATIONS: in hydraulic circuit with necessity of rapid pressure unloading by connecting the pressure line to the tank and max. pressure setting. Available for pumps type GL.  
FEATURES: Made in aluminium by using most advanced manufacturing facilities; easy maintenance; corrosion proof.

Unverbindliche Angaben. Änderungen vorbehalten. - Dimensions not binding. Modifications reserved without prior notice.  
Property of HANSA-TMP SRL. Copying without authorisation will be persecuted by Law.  
Eigentum von HANSA-TMP SRL. Nicht genehmigtes Kopieren wird strafrechtlich verfolgt.













As HANSA-TMP has a very extensive range of products and some products have a variety of applications, the information supplied may often only apply to specific situations.

If the catalogue does not supply all the information required, please contact HANSA-TMP.

In order to provide a comprehensive reply to queries we may require specific data regarding the proposed application.

Whilst every reasonable endeavour has been made to ensure accuracy, this publication cannot be considered to represent part of any contract, whether expressed or implied.

The data in this catalogue refer to the standard product. The policy of HANSA-TMP consists of a continuous improvement of its products. It reserves the right to change the specifications of the different products whenever necessary and without giving prior information.



**HYDRAULIC COMPONENTS  
HYDROSTATIC TRANSMISSIONS  
GEARBOXES - ACCESSORIES**

Via M. L. King, 6 - **41122 MODENA (ITALY)**  
Tel: +39 059 415 711  
Fax: +39 059 415 729 / 059 415 730  
INTERNET: <http://www.hansatmp.it>  
E-MAIL: [hansatmp@hansatmp.it](mailto:hansatmp@hansatmp.it)