

KRACHT

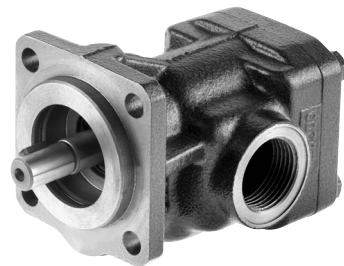

Transfer Gear Pumps
for Fuels

KF-F 2.5...112

Construction

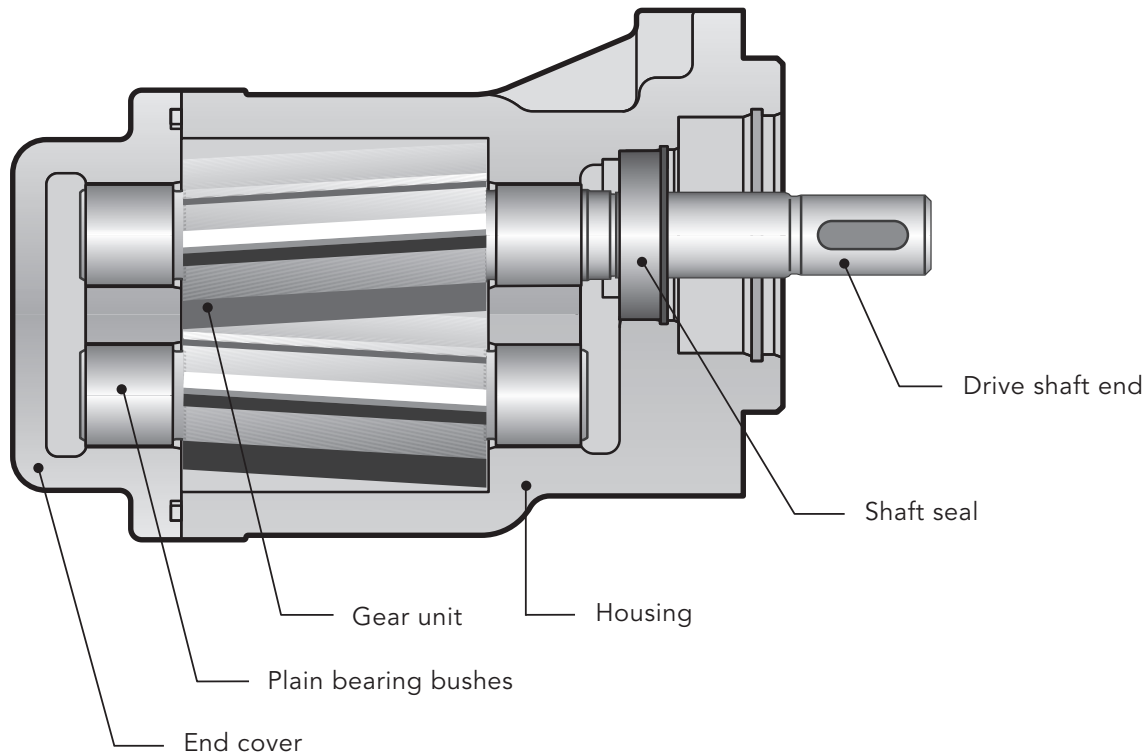

Description

The Type KF-F transfer pumps were developed specifically for use with fuels, especially for marine fuels.

These need to be critically considered, especially regarding the lubricity. And above all, those with low sulphur. Diesel fuels (MGO/DMA) exhibit low lubricity, which cannot be determined through the viscosity. Special methods are available for determining the tribological properties.

The HFRR test acc ISO 12156 is a recognised method for measuring the lubricity of diesel fuels. The characteristic value determined using this method is referred to as Wear Scar Diameter (WSD) and increases with decreasing lubricity. This characteristic value is stated by the fuel manufacturers and can be included when assessing the stability of components.

The KF-F fuel pumps are durable up to a WSD value of 520 µm, which is the minimum lubricity of MGO and DMA according to ISO 8217.

Furthermore, the pumps exhibit extremely good efficiency, especially at high speeds.

The KF-F pumps can be used without restrictions

for pumping fuels with low sulphur content, MGO/DMA (gas oil) acc ISO 8217 (see working characteristics).

Direction of Rotation

The following should be note for direction of rotation:

- when looking at the pump shaft end, the direction of pumping is from left to right if the shaft rotates **clockwise**.
- when looking at the pump shaft end, the direction of pumping is from right to left if the shaft rotates **counterclockwise**.

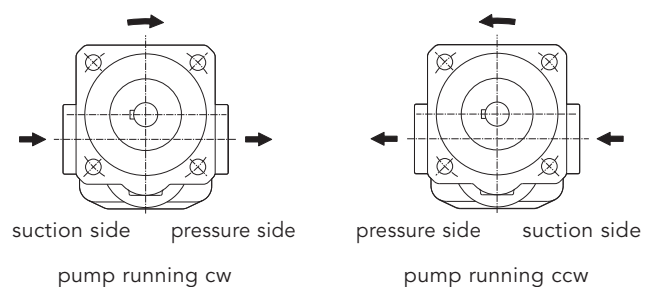

Materials

Housing and cover	EN-GJS-400-15 (GGG 40)
Gear	Steel 1.7139
Bearing	Multi-layer friction type bearing
Shaft end seals	Rotary shaft lip-type seal FKM Mechanical seal FKM Magnetic coupling
O-ring	FKM

Properties of fuels

Viscosity	$v_{\min} = 1.2 \text{ mm}^2/\text{s}$ $v_{\max} = 20\,000 \text{ mm}^2/\text{s}$ (dependent on pressure, speed and lubricity)
Lubricity HFRR-test (according to ISO 12156)	WSD $\leq 520 \mu\text{m}$ (meet the requirements of ISO 8217 for marine fuels)

Characteristics

Nominal sizes 2.5...112 cm ³	$V_g = 2.5/4/5/6/8/10/12/16/20/25/32/40/50/63/80/100/112$
Direction of rotation	right or left
Fixing type	flange (DIN ISO 3019)
Pipe connection	KF-F 2.5...25 Whitworth-pipe thread, SAE flange KF-F 32...112 SAE flange
Drive shaft end	ISO R 775 short-cylindrical

Working Characteristics

Fuel temperature	- 10 °C... 150 °C
Ambient temperature	- 20 °C... 60 °C
Working pressure	inlet port see chart page 6 outlet port $p_{\max} = 12 \text{ bar}$ at $v = 1.2 \text{ mm}^2/\text{s}$ for displacement 2.5... 112 $p_{\max} = 25 \text{ bar}$ at $v \geq 12 \text{ mm}^2/\text{s}$ (dependent on viscosity)
Driving Speed	$n = 200 \dots 3600 \text{ 1/min}$ for displacement 2.5... 63 cm ³ $200 \dots 3000 \text{ 1/min}$ for displacement 80... 112 cm ³ (observe the restricted drive speed for higher viscosities)
Volumetric efficiency	strongly dependent to drive speed, viscosity and pressure Example: 6 bar, 2 mm ² /s, 1450 1/min: $\eta > 70 \%$ 6 bar, 2 mm ² /s, 3600 1/min: $\eta > 90 \%$

Technical Data

Nominal size	geom. displacement V_g cm^3/r	Working pressure* $V \geq 12 \text{ mm}^2/\text{s}$ p_b bar	Maximum pressure (pressure peaks) $V \geq 12 \text{ mm}^2/\text{s}$ p_{max} bar	Speed range		Sound level dB (A)		
				n_{min} 1/min	n_{max} 1/min	$p = 5 \text{ bar}$	$p = 15 \text{ bar}$	$p = 25 \text{ bar}$
2.5	2.55	25	40	200	3600	≤ 65	≤ 66	≤ 67
4	4.03							
5	5.05							
6	6.38							
8	8.05							
10	10.11							
12	12.58							
16	16.09							
20	20.1							
25	25.1							
32	32.12							
40	40.21	25	40	200	3000	≤ 67	≤ 68	≤ 68
50	50.2							
63	63.18							
80	80.5							
100	101.5							
112	113.5							

Remark

* Working pressure p_b = perm. sustained pressure

For certain working conditions, the minimum or maximum characteristics should not be used.

For example, the max. working pressure is not permissible in combination with low speed and low viscosity.

In such limit ranges, please consult us.

Sound level measured in dB(A) at 1 m distance

Sound level measured with drive motor, installation site:

Works hall, quiet sound level = 40 dB(A)

Pump assembly on rigid fastening angle,

Suction and pressure conduits: Hose

Measured with transmission oil,

Oil viscosity $\nu = 34 \text{ mm}^2/\text{s}$,

Speed $n = 1500 \text{ 1/min}$.

Speed recommendation

Kinematic viscosity $\nu \text{ mm}^2/\text{s}$

< 300 300 500 1000 2000 3000 6000 10000 20000

≥ 1500 1250 1000 750 600 500 400 300 200

Speed $n_{\text{max}} \text{ 1/min}$

Shaft End Seals

	Sealing material	Pressure inlet port		Fuel temperature °C
		bar	bar	
Pump with rotary shaft lip-type seal	FKM	max. 750 1/min	KF-F 2.5 ... 80 -0.4 ... 6.0	KF-F 100/112 -0.4 ... 6.0
		max. 1000 1/min	-0.4 ... 5.0	-0.4 ... 5.0
		max. 1500 1/min	-0.4 ... 4.0	-0.4 ... 3.5
		max. 2000 1/min	-0.4 ... 3.0	-0.4 ... 2.5
		max. 3000 1/min	-0.4 ... 2.0	-0.4 ... 1.5
		max. 3600 1/min	-0.4 ... 1.0	-
Pump with mechanical seal	FKM		-0.4 ... 10.0	-10 ... 150
Pump with magnetic coupling			see page 8	-10 ... 150

Variants

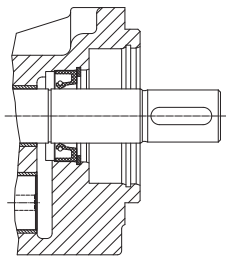

Pump with rotary shaft lip-type seal

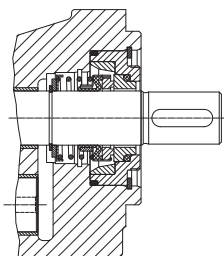

Pump with mechanical seal

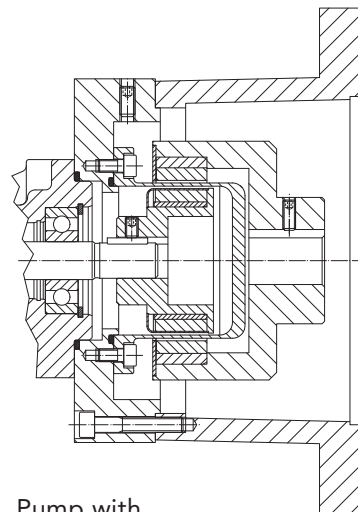

Pump with magnetic coupling

Type Key for fuel pumps with rotary shaft lip-type seal or mechanical seal

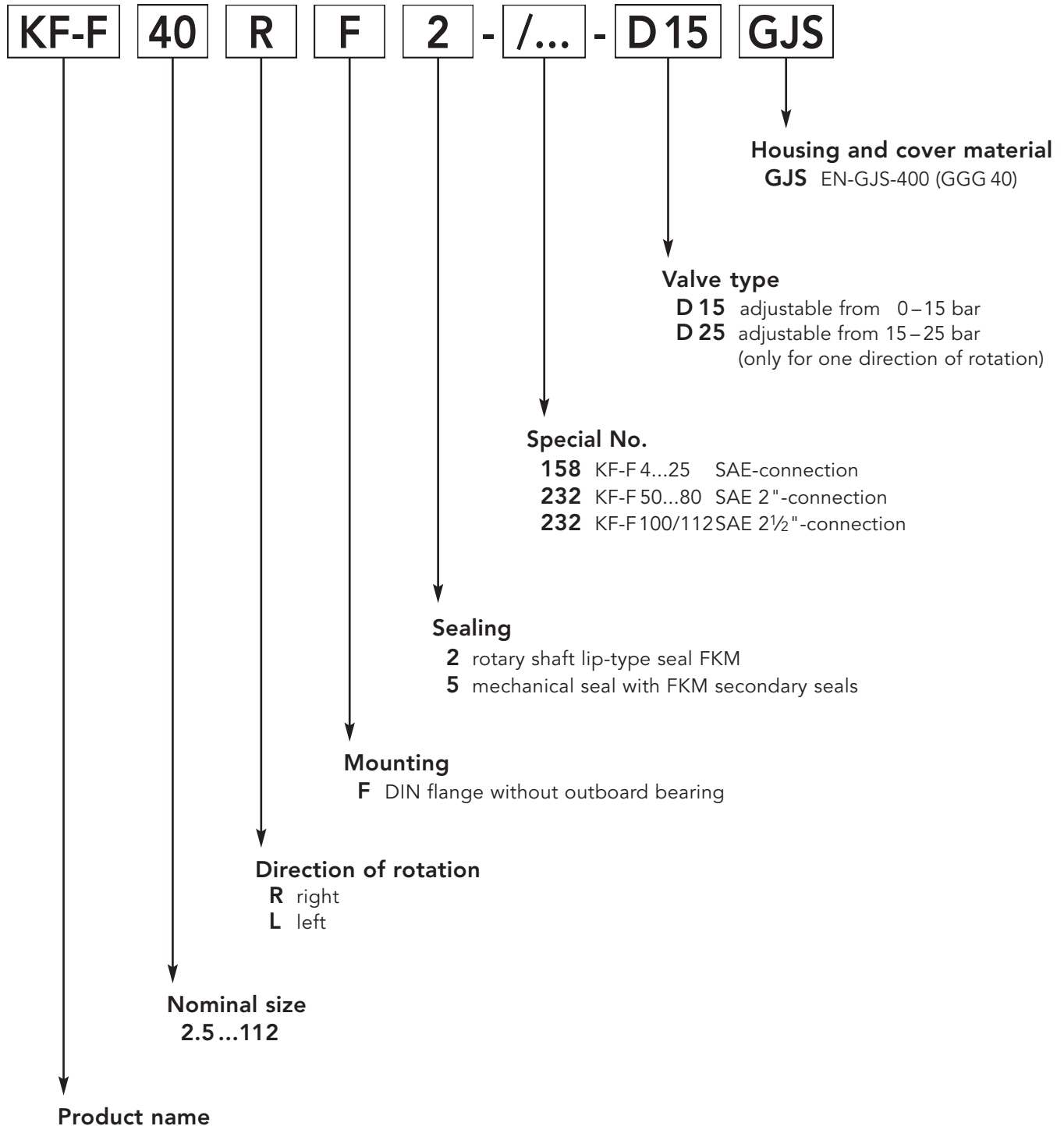

Description

The magnetic coupling serves as a shaft seal and for the transmission of the torque. The outer rotor of the magnetic coupling is assembled on the engine shaft and the inner rotor is assembled directly on the pumping shaft. The torque is transmitted through the magnetic forces between the outer and inner rotor. Between the two rotors, you have the split case which hermetically seals the pump.

The magnetic coupling is used when an absolute sealing is required between the pumping room and the atmosphere.

It can be used in vacuum operation in which an intrusion of air into the system is steadily prevented. Also, a leak-free operation is ensured when operating in closed systems with high pressure on the pump inlet side.

Materials magnetic coupling

Inner rotor	Hub made of stainless steel 1.4571 Magnets made of Sm2Co17 Magnet covering made of stainless steel 1.4571
Split case	Flange made of stainless steel 1.4571 Case made of stainless steel 1.4571 From construction size 75, alternatively made of Hastelloy
Outer rotor	Hub made of 355J2G3 (St 52) Magnet made of Sm2Co17

Characteristics

Nominal size 2.5 ...112 cm ³	$V_g = 2.5/4/5/6/8/10/12/16/20/25/32/40/50/63/80/100/112$
Direction of rotation	right or left
Fixing type	flange type
Pipe connection	KF 2.5 ...25 Whitworth-pipe thread, SAE flange KF 32 ... 112 SAE flange
Fitting position	horizontal, vertical (shaft end facing downward/at the bottom)

Working Characteristics

Fuel temperature	- 10 °C... 150 °C				
Ambient temperature	- 20 °C... 60 °C				
Working pressure	Inlet port	Operating $p_{e\ min} = -0.4$ bar, vacuum facility -0.92 bar $p_{e\ max} = 16$ bar (1) $p_{e\ max} = 25$ bar (2) $p_{e\ max} = 40$ bar (3) Standstill $p_{e\ min} = -1$ bar $p_{e\ max} = 16$ bar (1) $p_{e\ max} = 25$ bar (2) $p_{e\ max} = 40$ bar (3)			
Differential pressure	Outlet port	$p_{n\ max} = 25$ bar (dependent on viscosity)			
Nominal torque magnetic coupling	MSA 46/6	3 Nm	MSB 75/10	20 Nm	
	MSA 60/8	7 Nm	MSC 75/10	30 Nm	
	MSB 60/8	14 Nm	MSB 110/16	50 Nm	
	MSA 75/10	10 Nm	MSC 110/16	80 Nm	

Type Key

Ordering example for fuel pumps with magnetic coupling

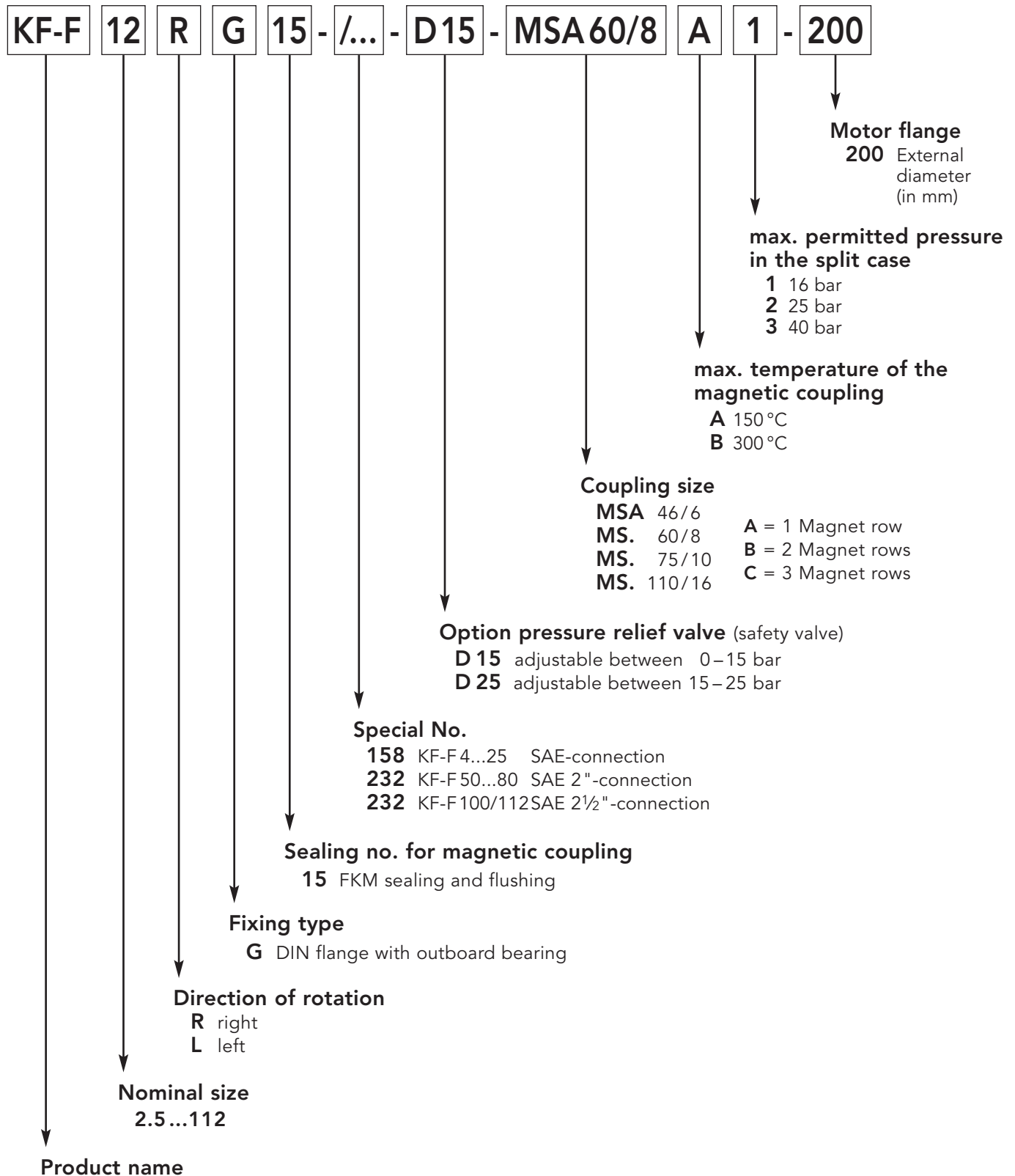

Selection Assistance

Pump	Coupling size	Stat. cut-off torque at 20 °C [Nm]	Permitted power consumption [kW] at n = 750 1/min	Motor size	Permitted power consumption [kW] at n = 1000 1/min	Motor size	Permitted power consumption [kW] at n = 1500 1/min	Motor size	Permitted power consumption [kW] at n = 3000 1/min	Motor size	
KF-F 2.5 ... 25	MSA 46	3	–	–	0.18	71	0,18	63	0,25	63	
							0.25	71	0.37	71	
	MSA 60	7	0.18	80	0.25	71	0.37	71	0.75	80	
											0.25
	MSB 60	14	0.37	90	0.55	80	0.75	80	1.5	90	
											0.55
	MSB 75	24	0.75	100	1.1	90	1.5	90	3.0	100	
											1.1
	KF-F 32 ... 112	MSB 75	24	0.75	100	1.1	90	1.5	90	3.0	100
MSC 75		40	1.5	112	2.2	112	3.0	100	5.5	132	
											2.2
MSB 110		60	3.0	132	4.0	132	5.5	132	11.0	160	
MSC 110		95	4.0	160	5.5	132	7.5	132	15.0	160	
											5.5

To design the magnetic coupling, the following information needs to be available:

- Pump size
- Pump pressure (working and starting pressure)
- Working and starting viscosity
- Precise name of media – required static seals (if possible) – possibly main media characteristics
- Drive motor power
- Speed or speed range
- Switch on type – direct or with frequency inverter
- Media and ambient temperature

Product Portfolio

Transfer Pumps

Transfer pumps for lubricating oil supply equipment, low pressure filling and feed systems, dosing and mixing systems.

Mobile Hydraulics

Single and multistage high pressure gear pumps, hydraulic motors and valves for construction machinery, vehicle-mounted machines.

Flow Measurement

Gear and turbine flow meters and electronics for volume and flow metering technology in hydraulics, processing and laquering technology.

Industrial Hydraulics / Test Bench Construction

Cetop directional control and proportional valves, hydraulic cylinders, pressure, quantity and stop valves for pipe and slab construction, hydraulic accessories for industrial hydraulics (mobile and stationary use).

Technology Test benches / Fluid Test benches.



KF-F.2.5...112/GB/07.11

KRACHT