

KRACHT

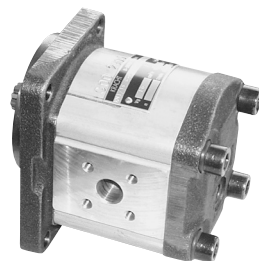
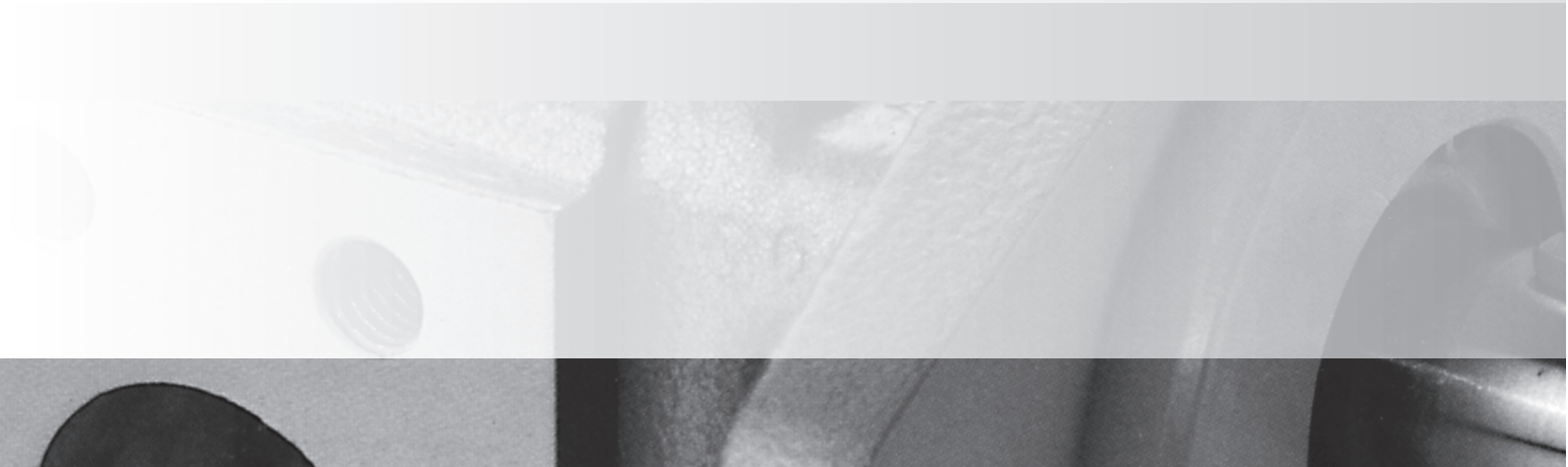

High Pressure Gear Motors

KM 1

Construction

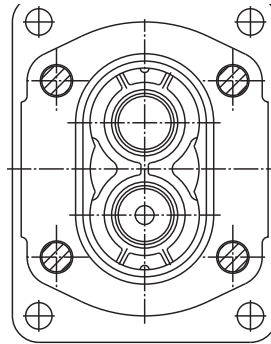
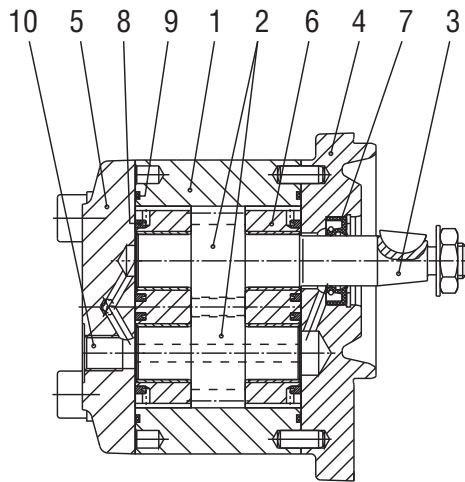

- 1 Housing
- 2 Gearing
- 3 Drive shaft end
- 4 Flange mounting cover
- 5 End cover
- 6 Double gland bearing with special plane bearing bushes
- 7 Rotary shaft lip-type seals
- 8 Pressure field sealing for axial clearance compensation
- 9 Sealing of the housing
- 10 Drain port

Function

Accordingly to its configuration – the Design principle is illustrated by the Sectional figure above – the KRACHT External Gear-Type Motor Series KM 1 is classified in the category of the so-called Gland-Type Bearing Motors.

All essential functional parts as the gearing and the gland bearings are located in an aluminium housing manufactured of a high strength extrusion alloy which is closed on each side by an end cover or by a flange mounting cover respectively.

The gearing of case hardening steel in surface hardened condition consists of the pinion shaft and the pinion.

Highest manufacturing quality is assured by grinding and honing of the tooth flanks.

The surfaces of the journals are super finished.

An important reduction of the type dependent deviation of the volumetric flow and of the pressure pulsation was achieved on the basis of the great teeth number ($z = 13$) and the specially shaped teeth.

The gland bearings located on both sides of the gearing carry the journals in heavy duty multicomponent plane bearing bushes and contain additionally those sealing elements which serve for the pressure field sealing to compensate the axial clearance.

If requested the engines with built up special valve can be delivered.

Multiple engine combinations are possible.

The optimal design of the pressure fields guarantees very good efficiencies over a wide pressure/speed range on the one hand – at the nominal working point for instance a total efficiency of 90% and above is reached – and ensures a smooth starting behaviour of the motor

on the other hand and that already at a low rate of the input flow.

As the pressure fields are symmetrically arranged the motors can be used as well for clockwise as for anticlockwise rotation (reversible working modes).

The pressure relief of the shaft seal is effected by the drain port to be found in the end cover, (note the max. permissible drain pressure) so that the motors may be pressurized at the outlet side, hence follows that it is possible to connect together several motors in series.

For high speed Operation the shaft seal must be of FKM-material, refer to page 5.

The combination of 2 motors for instance coupled together and provided with a common supply line makes a **Flow Divider** with a high dividing accuracy.

Note:

External loads

Radial or Axial loads acting on the shaft end impair the functions of the gland bearings. Radial loads can possibly be absorbed in dependence on the extent and the direction of the loads.

Axial loads are NOT permissible.

To absorb external loads the motor type with outboard bearing must be used.

New (on request):

These engines are also available with reduced flank clearance. This results in lower pulsation and considerably improved start-up behaviour.

General Characteristics

Mounting	flange and foot-type
Pipe connection	flange-type
Direction of rotation	clockwise and anticlockwise
Weight	refer to dimensional sheet
Fitting position	optional
Permissible ambient temperature range	$\vartheta_{u \min} = - 20\text{ }^{\circ}\text{C}$ $\vartheta_{u \max} = + 60\text{ }^{\circ}\text{C}$

Working Characteristics

Working pressures

Input side	$p_{1 \max}$ = refer to technical data
Outlet side	$p_{2 \max}$ = 120 bar
Drain pressure	$p_{T \max}$ = 2 bar
Short time	$p_{T \max}$ = 5 bar

Fluid temperature range	$\vartheta_{m \max}$ = 90 °C for NBR rotary shaft lip-type seal 100 °C for FKM rotary shaft lip-type seal
-------------------------	--

Viscosity range	v_{\min} = 10 mm ² /s v_{\max} = 600 mm ² /s
-----------------	---

Filtration	ISO 4406 : 1999 code 21/19/16 (NAS 1638 class 10)
------------	---

Grade of filtration	β_{25} ≥ 75 for ... 300 bar β_{40} ≥ 75 for ... 100 bar
---------------------	--

Recommended Viscosity range	v = 30 ... 45 mm ² /s
-----------------------------	------------------------------------

Characteristic curves	refer to pages 6 – 10
-----------------------	-----------------------

Hydraulic fluids	Mineral oil acc. DIN 51524/25 Mineral oil acc. DIN 51511 bio-oils of type „HEES“, can be used up to 70 °C, max. pressure must be reduced minus 20 % (use only on request)
------------------	---

Materials

Housing	aluminium
Bearing	double gland bearing with multicomponent plane bearing bushes
Journals and gears	ase hardening steel acc. to DIN 17210 surface hardened and ground
Seals	1 NBR rotary shaft lip-type seal $\vartheta \leq 90\text{ }^{\circ}\text{C}$ (PU sealing for pressure field) 2 FKM rotary shaft lip-type seal $\vartheta \leq 100\text{ }^{\circ}\text{C}$ (PU sealing for pressure field)

Direction of rotation

Regarding the direction of rotation basically the following applies provided the view is directed toward the drive shaft end:

Drive shaft end rotating clockwise:	Oil flow from left to right.
Drive shaft end rotating anticlockwise:	Oil flow from right to left.

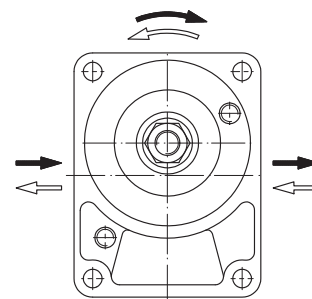

Options Hydraulic Fan Drive Solutions

- KM 1 with pressure relief valve (standard and space optimized)
- KM 1 with proportional valve (standard and space optimized)
- KM 1 with proportional valve and reversible unit (standard and space optimized)
- KM 1 with ON-OFF function
- KM 1 with pressure relief valve and reversible unit
- KM 1 with thermostatic valve and pressure relief valve
- KM 1 with thermostatic valve and pressure relief valve with reversible unit

Technical Data

Nominal motor displacement	Geom. motor displacement		max. pressure p_{max} bar	Rated pressure p_N bar	Working pressure p_D bar	max. working speed		Moment of inertia $\times 10^{-6}$ J kg m ²
	V_g cm ³ /r					n_{max} 1/min		
	4 NL	4 NM				NBR	FKM	
5.5	5.45	5.60	300	280	250	3000	4000	35.7
6.3	6.28	6.45	300	280	250	3000	4000	39.9
8	7.90	8.16	300	280	250	3000	4000	51.1
9.6	9.59	9.86	300	280	250	3000	4000	56.5
11	10.90	11.20	300	280	250	3000	4000	62.9
14	13.85	14.25	300	280	250	3000	4000	77.7
16	15.90	16.32	260	240	210	3000	4000	87.7
19	18.80	19.37	220	200	180	3000	4000	102.5
22	22.30	22.90	200	180	150	3000	4000	119.6
25	25.21	25.97	200	180	150	3000	4000	135.3

Note: Allowed torque for the shaft end follow!

Time / Pressure chart

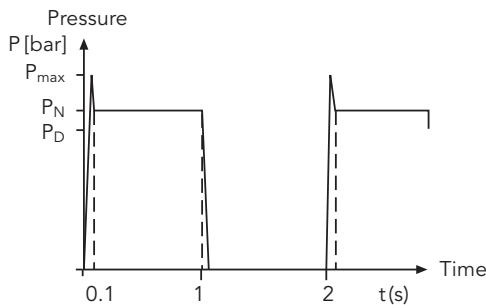

Maximum pressure Δ pressure peak
 Rated pressure $p_N < 6s \Delta 50\%$ ED
 see time / pressure chart
 max. perm. working cycles: 30/min
 Pressures as specified are applicable
 to $v \geq 30$ mm²/s

Calculation Formulas for Hydraulic Pumps and Motors

Characteristic data, formula signs, units

- | | | |
|--------------------------------|--------------|--------------------|
| 1. Discharge flow / input flow | Q | l/min |
| 2. Pump / motor displacement | V_g | cm ³ /r |
| 3. Pressure | p | bar |
| 4. Speed | n | 1/min |
| 5. Torque | M | Nm |
| 6. Power | P | kW |
| 7. Total efficiency | η_{tot} | — |
| 8. Volumetric efficiency | η_{vol} | — |
| 9. Hydr./mech. efficiency | η_{hm} | — |
| 10. Flow velocity | v | m/s |
| 11. Piping diameter | d | mm |

General

- 1 Δ input, driven
 2 Δ output, driving

$$Q_{th} = V_g \cdot n, \quad \eta_{tot} = \eta_{vol} \cdot \eta_{hm}$$

$$M = 9549 \cdot \frac{P}{n}, \quad v = 21.22 \frac{Q}{d^2}$$

Approximate values for
 KRACHT products in the
 nominal working point

	η_{tot}	η_{vol}
KP	≈ 0.85	≈ 0.93
KM	≈ 0.85	≈ 0.93

Characteristic data for:	Volumetric flow	Discharge flow $Q_2 = \frac{V_g \cdot n_1 \cdot \eta_{vol}}{10^3} \left[\frac{l}{min} \right]$	Input flow $Q_1 = \frac{V_g \cdot n_2}{10^3 \cdot \eta_{vol}} \left[\frac{l}{min} \right]$
	Torque	Drive torque $M_1 = \frac{p \cdot V_g}{20 \cdot \pi \cdot \eta_{hm}} \text{ [Nm]}$	Output torque $M_2 = \frac{\Delta p \cdot V_g \cdot \eta_{hm}}{20 \cdot \pi} \text{ [Nm]}$
	Power	Input power $P_1 = \frac{p \cdot Q_2}{600 \cdot \eta_{tot}} \text{ [kW]}$	Output power $P_2 = \frac{\Delta p \cdot Q_1 \cdot \eta_{tot}}{600} \text{ [kW]}$

Guidance for use of the Characteristic Curves

Required: Torque output M at speed n
 Unknown: Pressure difference Δp and the required Input flow Q

Example: $M = 45 \text{ Nm}$ → ①
 $n = 1400 \text{ 1/min}$ ↑ ②

The Intersection of ① and ② is the motor working point with:
 $\Delta p = 142 \text{ bar}$ → ③
 $Q = 32.2 \text{ l/min}$ ↓ ④

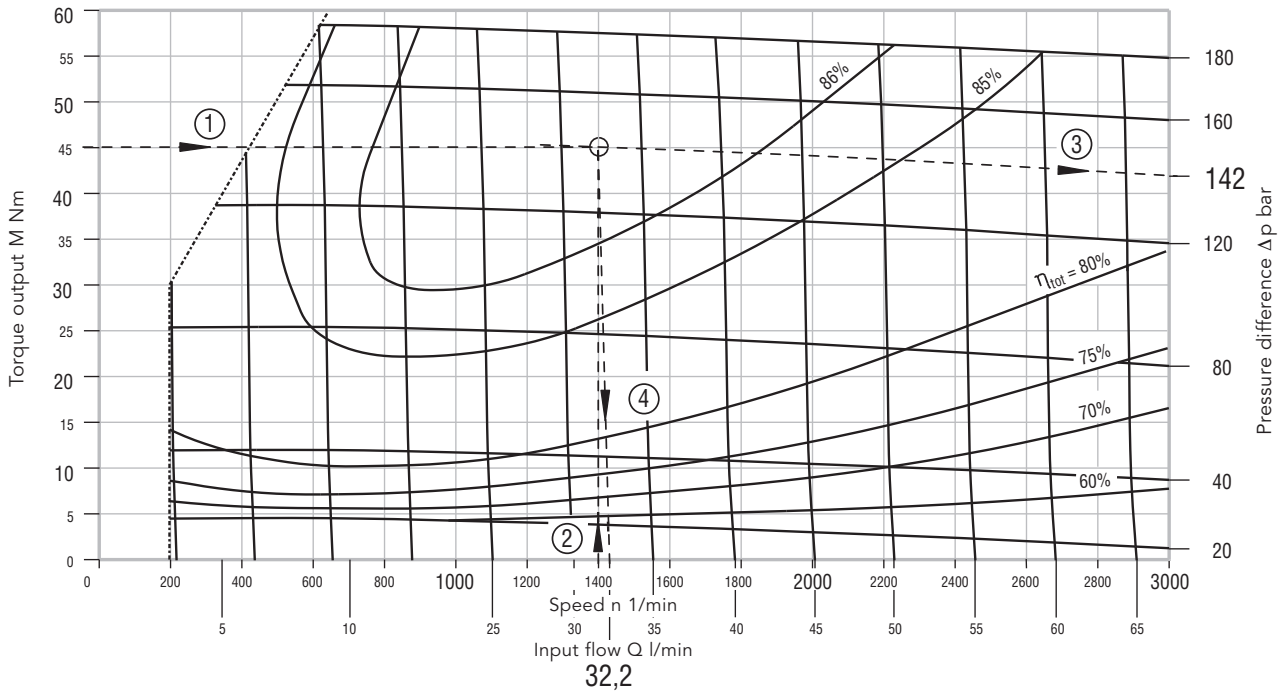

Characteristic Curves for Type KM 1/5.5

Characteristic values applicable to viscosity $\nu = 34 \text{ mm}^2/\text{s}$ · Dispersion of the speed values $n = \pm 75 \text{ 1/min}$
 Dispersion of the torque output $M = \pm 1.1 \text{ Nm}$ at $\Delta p = \text{constant}$ and $Q = \text{constant}$

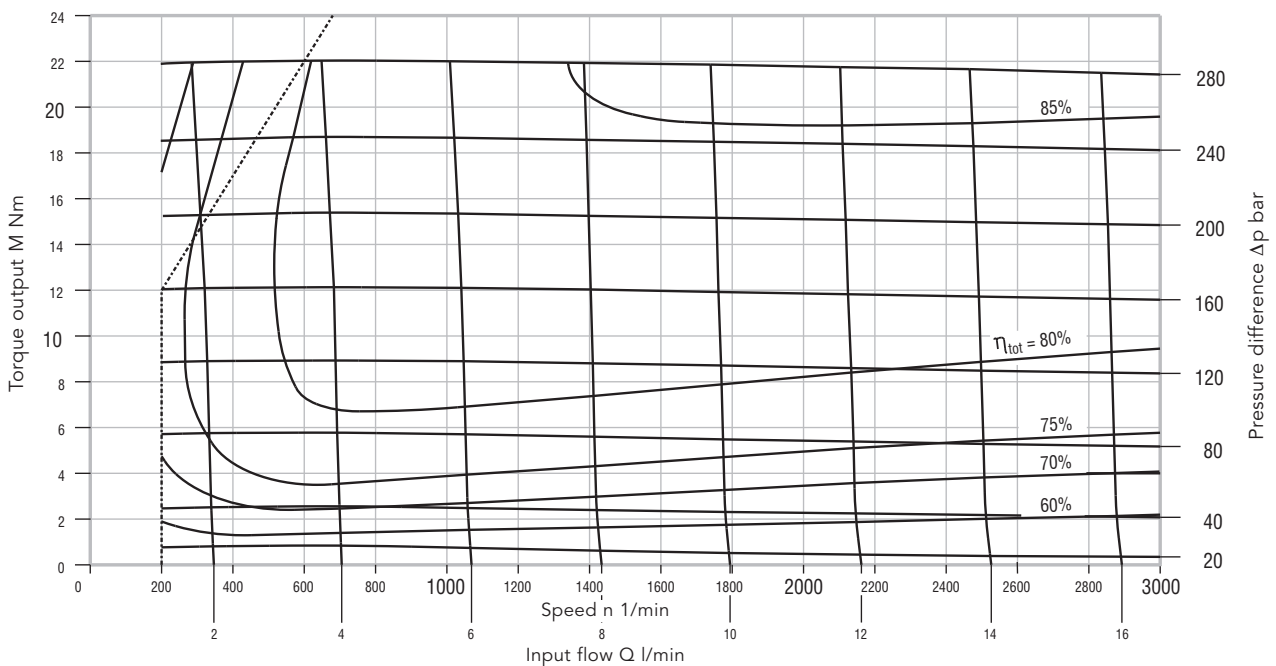

Characteristic Curves for Type KM 1/8

Characteristic values applicable to viscosity $\nu = 34 \text{ mm}^2/\text{s}$ · Dispersion of the speed values $n = \pm 75 \text{ 1/min}$
 Dispersion of the torque output $M = \pm 1.6 \text{ Nm}$ at $\Delta p = \text{constant}$ and $Q = \text{constant}$

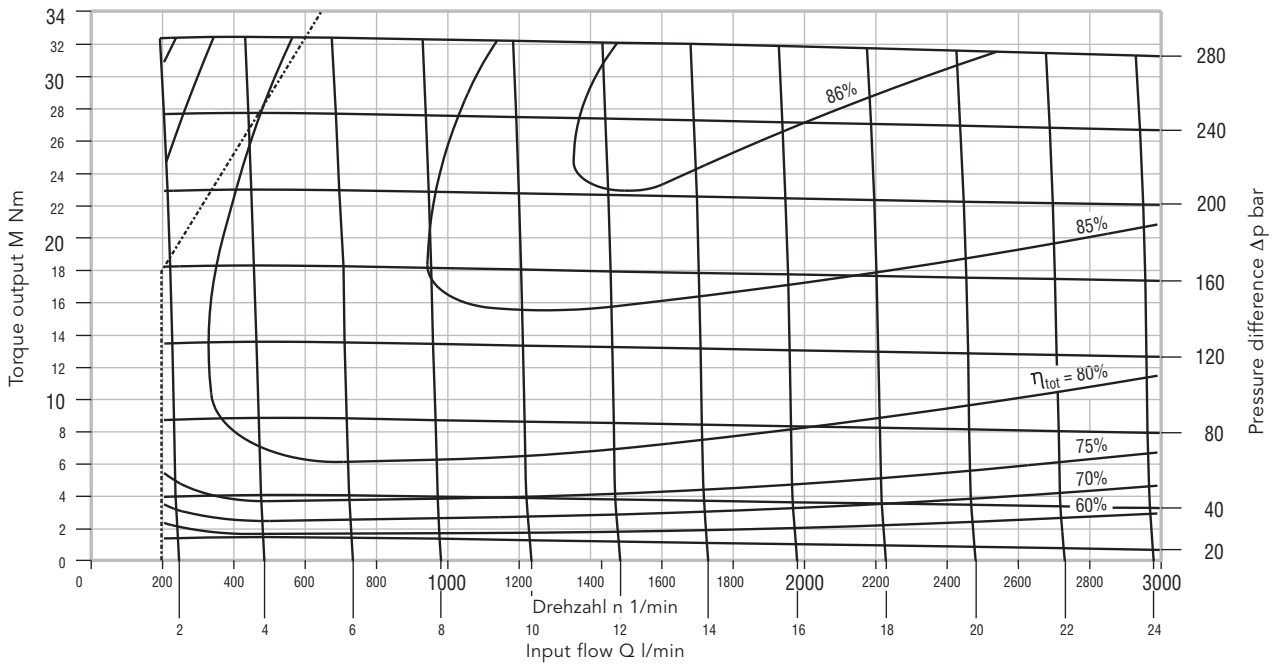

Characteristic Curves for Type KM 1/11

Characteristic values applicable to viscosity $\nu = 34 \text{ mm}^2/\text{s}$ · Dispersion of the speed values $n = \pm 75 \text{ 1/min}$
 Dispersion of the torque output $M = \pm 2.2 \text{ Nm}$ at $\Delta p = \text{constant}$ and $Q = \text{constant}$

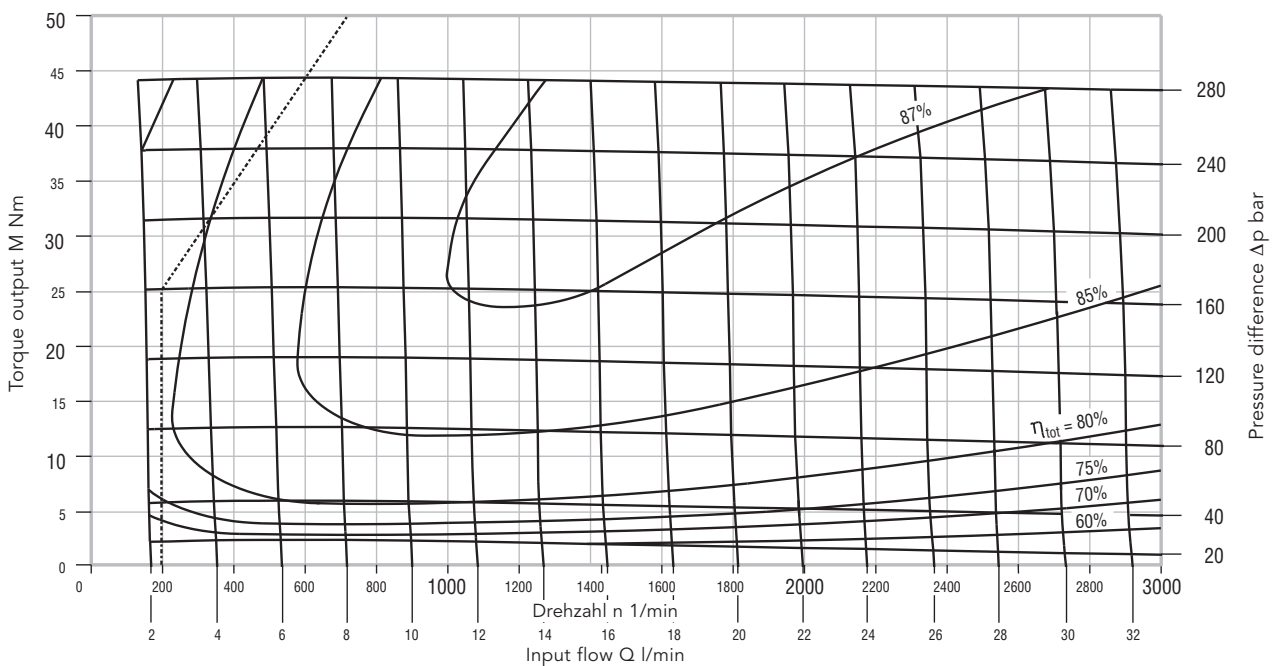

Characteristic Curves for Type KM 1/14

Characteristic values applicable to viscosity $\nu = 34 \text{ mm}^2/\text{s}$ · Dispersion of the speed values $n = \pm 75 \text{ 1/min}$
 Dispersion of the torque output $M = \pm 2.8 \text{ Nm}$ at $\Delta p = \text{constant}$ and $Q = \text{constant}$

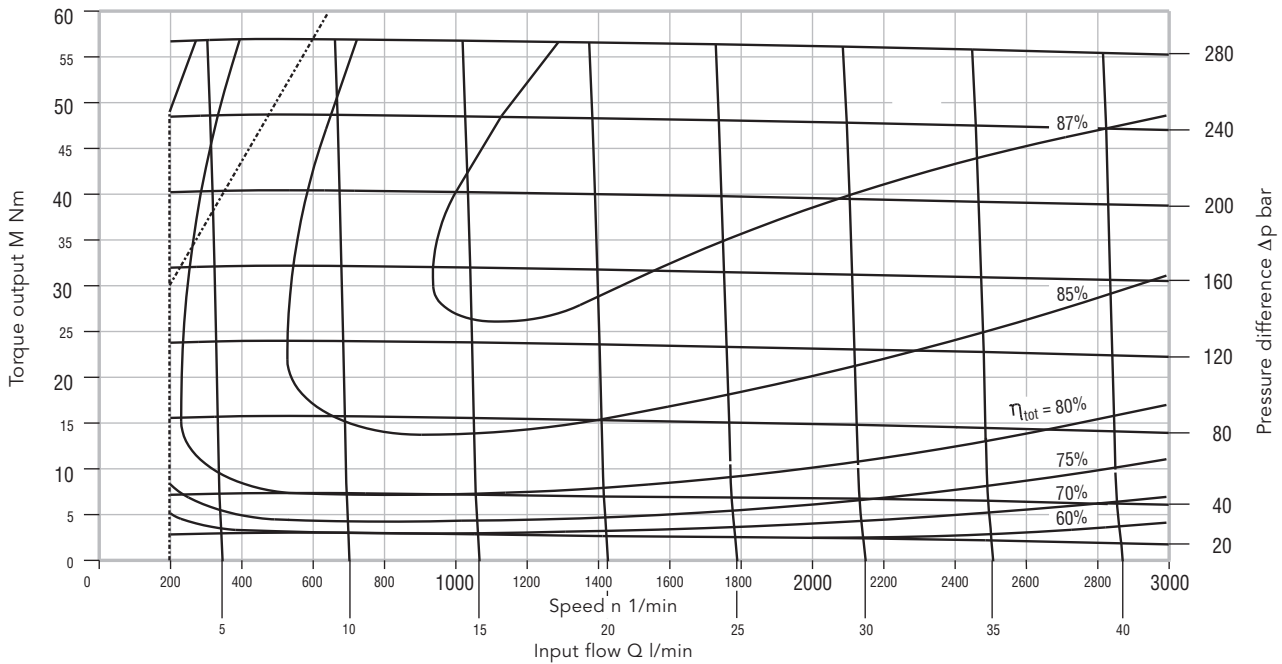

Characteristic Curves for Type KM 1/16

Characteristic values applicable to viscosity $\nu = 34 \text{ mm}^2/\text{s}$ · Dispersion of the speed values $n = \pm 75 \text{ 1/min}$
 Dispersion of the torque output $M = \pm 2.8 \text{ Nm}$ at $\Delta p = \text{constant}$ and $Q = \text{constant}$

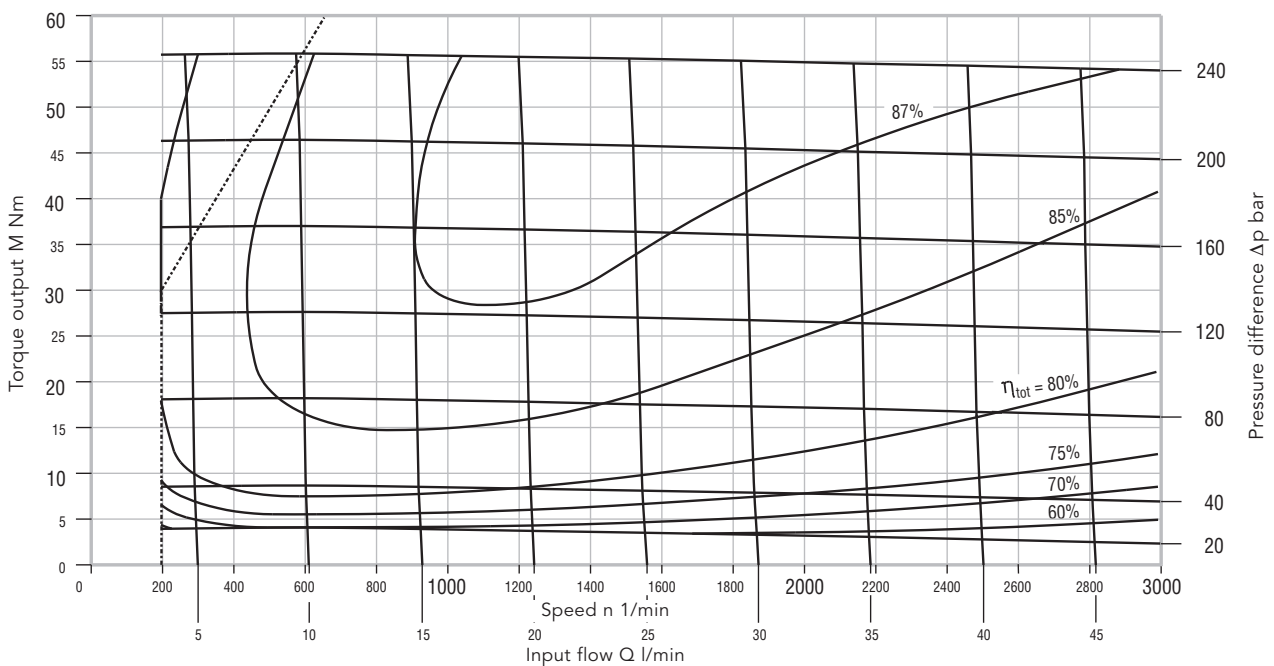

Characteristic Curves for Type KM 1/19

Characteristic values applicable to viscosity $\nu = 34 \text{ mm}^2/\text{s}$ · Dispersion of the speed values $n = \pm 75 \text{ 1/min}$
 Dispersion of the torque output $M = \pm 2.2 \text{ Nm}$ at $\Delta p = \text{constant}$ and $Q = \text{constant}$

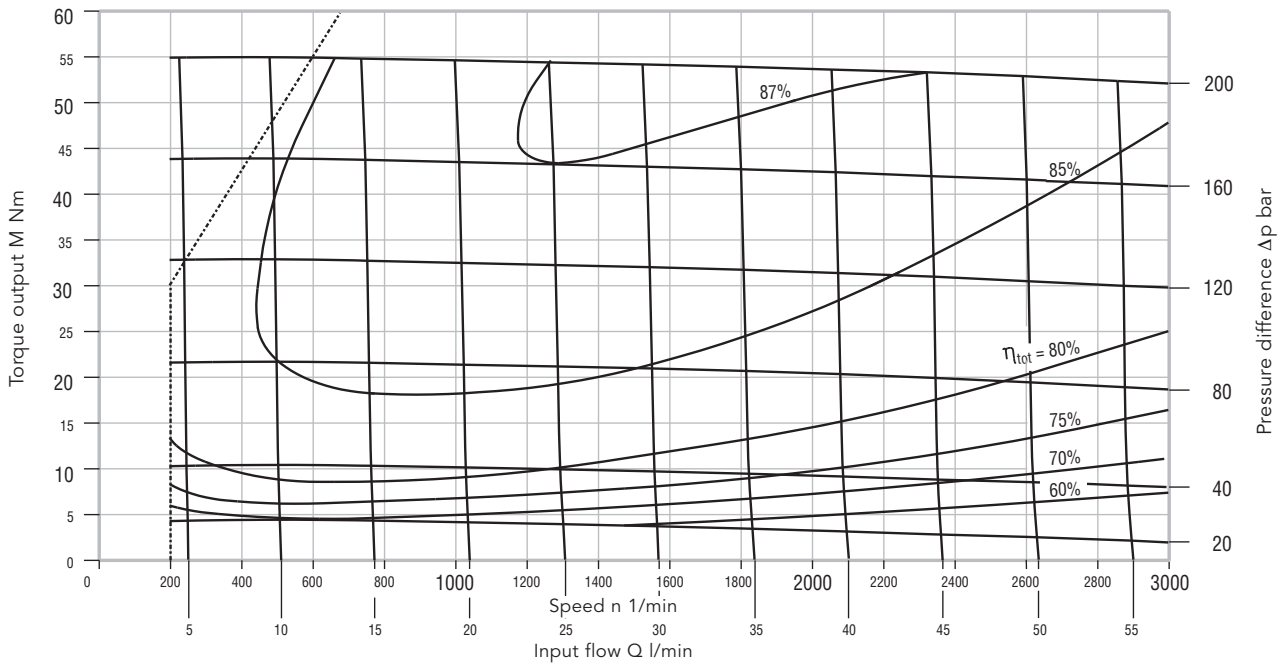

Characteristic Curves for Type KM 1/22

Characteristic values applicable to viscosity $\nu = 34 \text{ mm}^2/\text{s}$ · Dispersion of the speed values $n = \pm 75 \text{ 1/min}$
 Dispersion of the torque output $M = \pm 2.8 \text{ Nm}$ at $\Delta p = \text{constant}$ and $Q = \text{constant}$

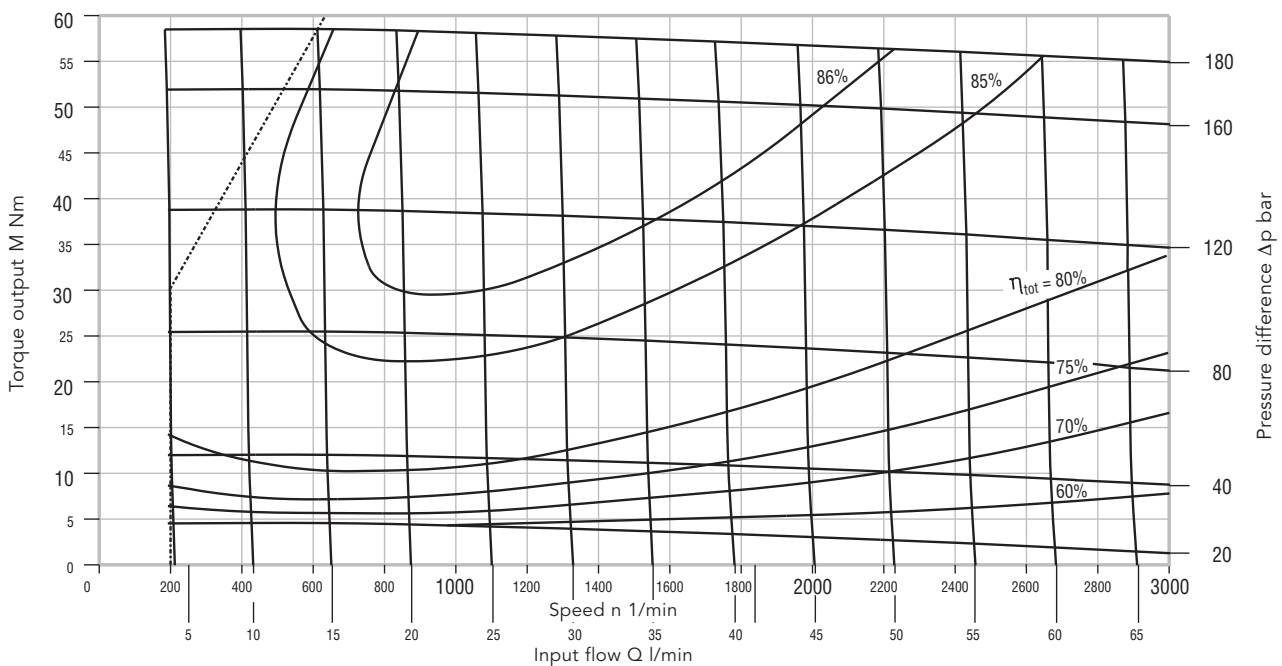

Characteristic Curves for Type KM 1/25

Characteristic values applicable to viscosity $\nu = 34 \text{ mm}^2/\text{s}$ · Dispersion of the speed values $n = \pm 75 \text{ 1/min}$
 Dispersion of the torque output $M = \pm 2.8 \text{ Nm}$ at $\Delta p = \text{constant}$ and $Q = \text{constant}$

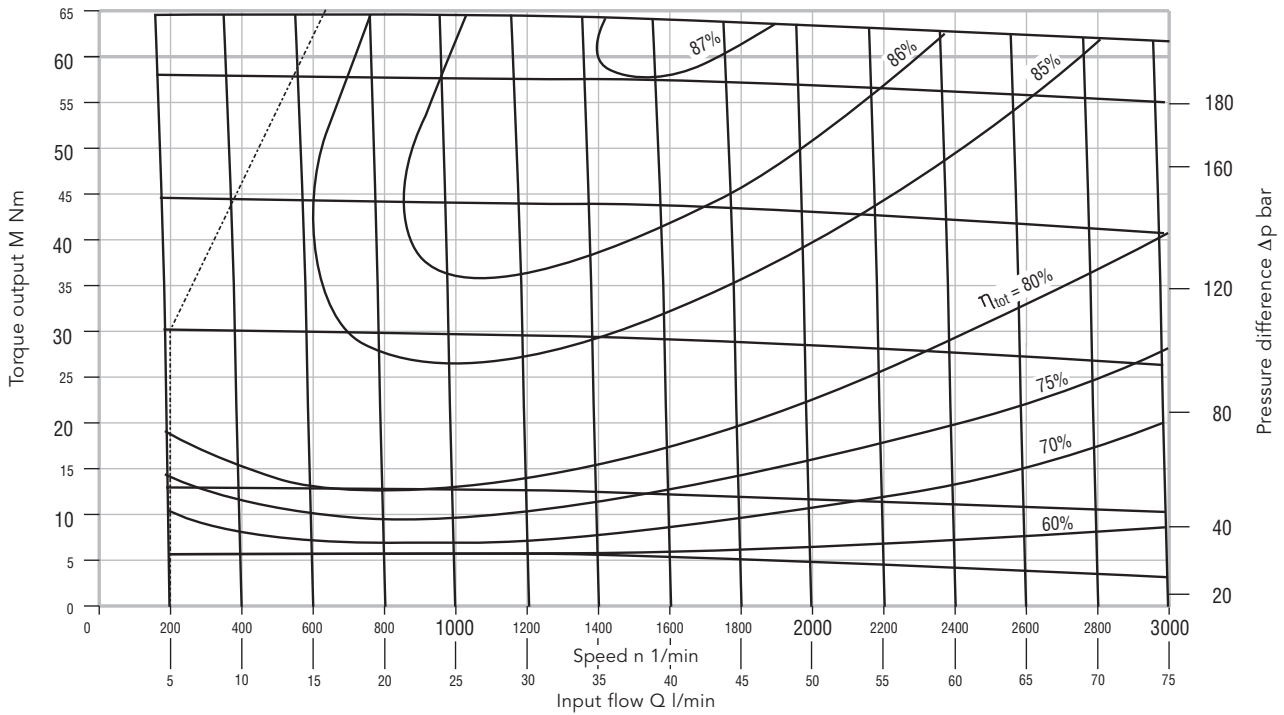

Type Key

Shaft ends

- F** with two parallel flats $M_{max} = 40 \text{ Nm}$
- K** Taper 1: 5 $M_{max} = 160 \text{ Nm}$
- M** Taper 1: 8 $M_{max} = 160 \text{ Nm}$
- S** Involute spline SAE-A, DP 16/32, $\alpha = 30^\circ$, $z = 9$, $M_{max} = 55 \text{ Nm}$
- X** Involute spline B 17 x 14, DIN 5482, $M_{max} = 70 \text{ Nm}$

Housing ports

- A** $\varnothing 15$ with LK 35
- C** G 1/2 (on request)
- D** M 22 x 1.5 (on request)
- J** 7/8 – 14 UNF (on request)
- Q** $\varnothing 13.5$ with LK 30.2
(Input and outlet side equally sized)

Outboard flanges or bearing resp.

- 0** without
- L** Bearing series: light
- P** Bearing series: heavy
- R** Mounting angle

Second shaft end

- 0** without
- X** Involute spline
B 17 x 14, DIN 5482

End cover (adaptor pieces)

- A** End cover (standard type)
- B** End cover with side drain port
- F** Adaptor piece for multi-stage pump types KM1 coupled with KM1 only

Design serial no.

- 4** (Specified by Kracht)

Code for materials

- N** Housing:
Aluminium double
bland bearing with
multicomponent
plane bearing
bushes

Ordering example

KM	1/	5.5	G	3	0	A	K	0	A	4	N	L	1/	.
----	----	-----	---	---	---	---	---	---	---	---	---	---	----	---

Type of gearing

- L** Driving and driven gears of case hardening steel
(tooth flanks grinded and hones)
- M** reduced backlash of teeth

Direction of rotation

- 3** clockwise and anticlockwise

Selection: flange mounting cover

- A** SAE-A-2-bolt type, $LA = 106.4$; $\varnothing Z = 82.55$
- F** 2 bolt square flange, $LA = 60/60$; $\varnothing Z = 50$
- G** 4 bolt rectangular flange, $LA = 72/100$; $\varnothing Z = 80$
- K** 4 bolt rectangular flange, $LA = 71.4/96.1$; $\varnothing Z = 36.47$
- L** 2 bolt rectangular flange, $LA = 60/60$; $\varnothing Z = 52$
with O-ring (without shaft seal)
- M** same as type F;
but the bolting is mirror inverted
- Q** 2 bolt square flange, $LA = 60/60$; $\varnothing Z = 52$ with O-ring
($LA =$ mounting hole distance, $\varnothing =$ centering diameter)

Nominal motor displacement

- 5.5 / 6.3 / 8 / 9.6 / 11 / 14 / 16 / 19 / 22 / 25

Seals

- 1** NBR rotary shaft lip type seals
 $\vartheta \leq 90^\circ\text{C}$
- 2** FKM rotary shaft lip type seals
 $\vartheta \leq 100^\circ\text{C}$

Size 1

Product name

Code no. for special construction

G-Flange, Tapered Shaft End

Ordering example:

KM 1/8 G30A K0A 4NL1

Shaft end: taper 1:5
 Hex. lock nut M 12 x 1.5
 EN ISO 8675
 Curved spring washer B12 DIN 137
 Woodruff key 3 x 6.5 DIN 6888

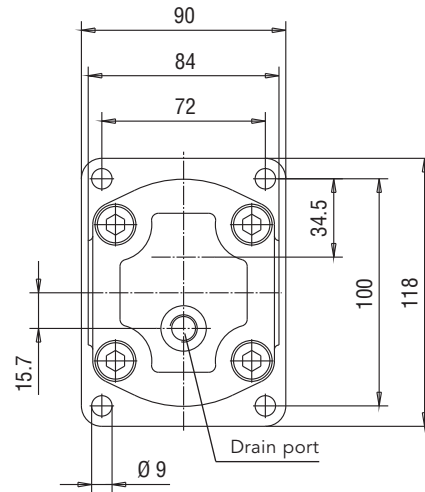
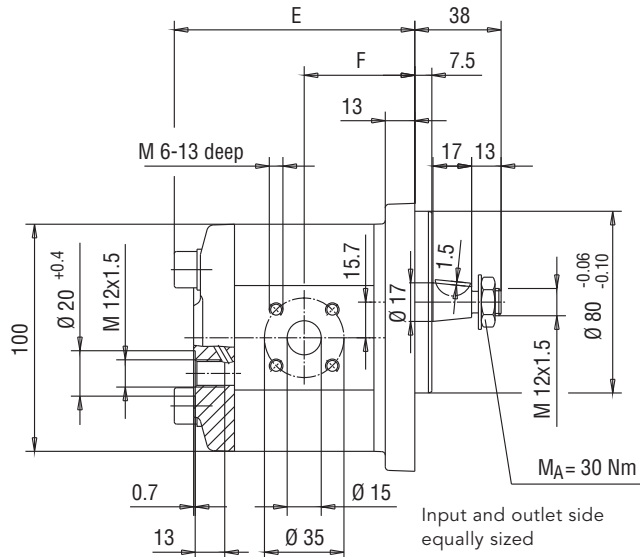

G-Flange, Involute Spline Shaft End

Ordering example:

KM 1/8 G30A X0A 4NL1

Shaft end: involute spline
 B 17 x 14 DIN 5482
 but tooth thickness $S_w = 3.206$
 Addendum modification = +0.6

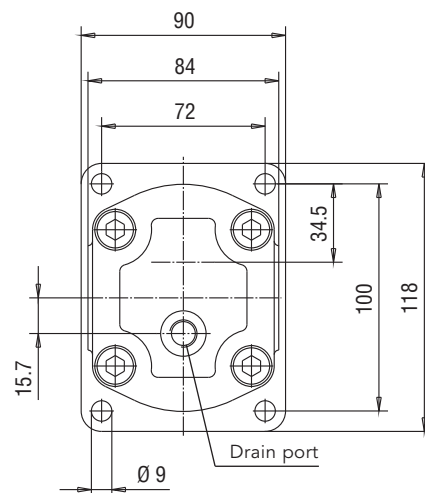
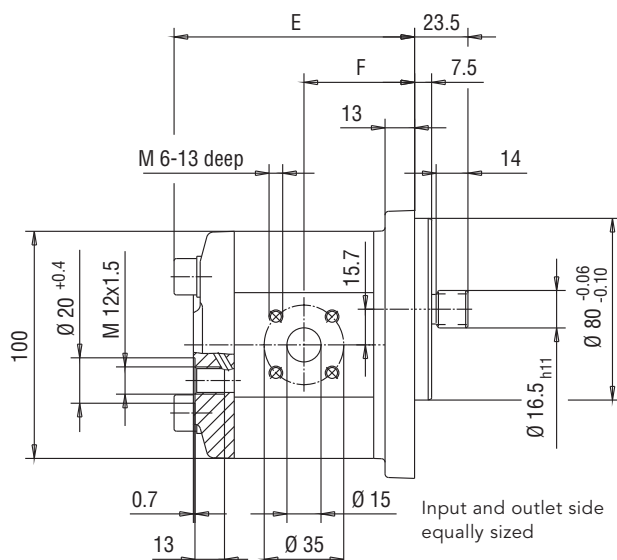

Displacement Nominal size	5.5	6.3	8	9.6	11	14	16	19	22	25
E	91.7	93.1	95.9	98.7	100.9	105.9	109.3	114.3	120.1	125.3
F	41.6	42.3	43.7	45.1	46.2	48.7	50.4	52.9	55.8	58.4
Weight kg	2.2	2.3	2.3	2.4	2.5	2.6	2.8	2.9	3.1	3.3

End Cover B

End cover B available for all types of motor.

Connection of the drain piping optional on the right or left side.

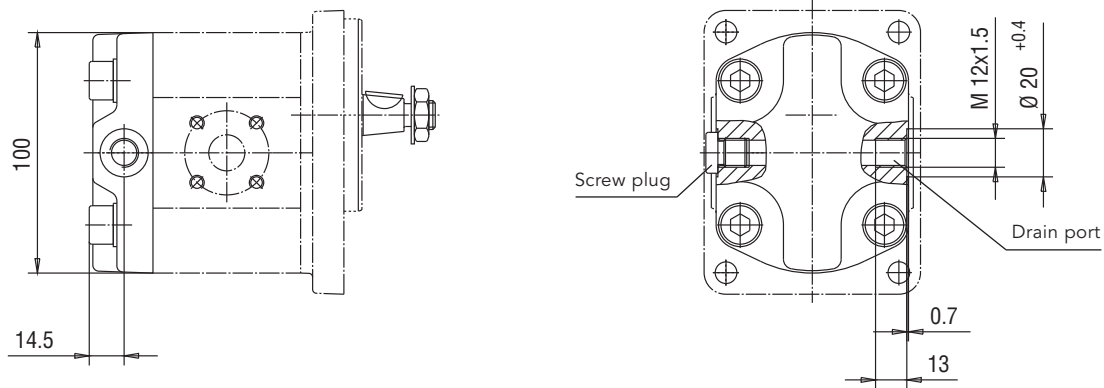

SAE A-Flange, Tapered Shaft End

Ordering example:

KM 1/8 A30A K0A 4NL1

Shaft end: taper 1:5

Hex. lock nut M 12 x 1.5

EN ISO 8675

Curved spring washer B12 DIN 137

Woodruff key 3 x 6.5 DIN 6888

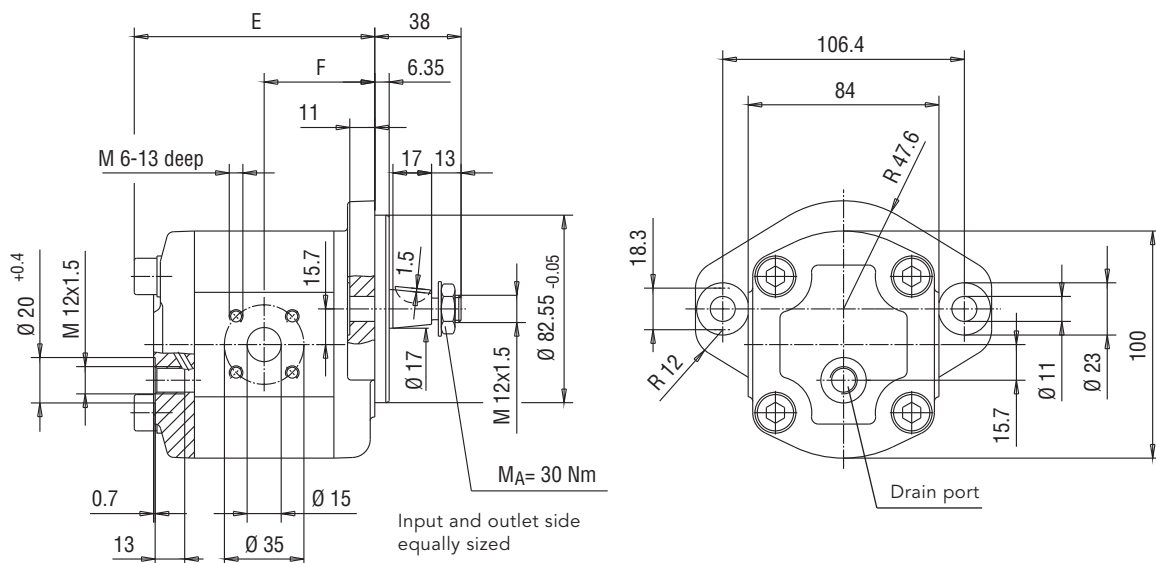

SAE A-Flange, SAE A-Shaft-End

Ordering example:

KM 1/8 A30A S0A 4NL1

Shaft end: involute spline
SAE-A $z = 9$; DP 16/32; $\alpha = 30^\circ$
allowed torque $M_{max} = 55 \text{ Nm}$

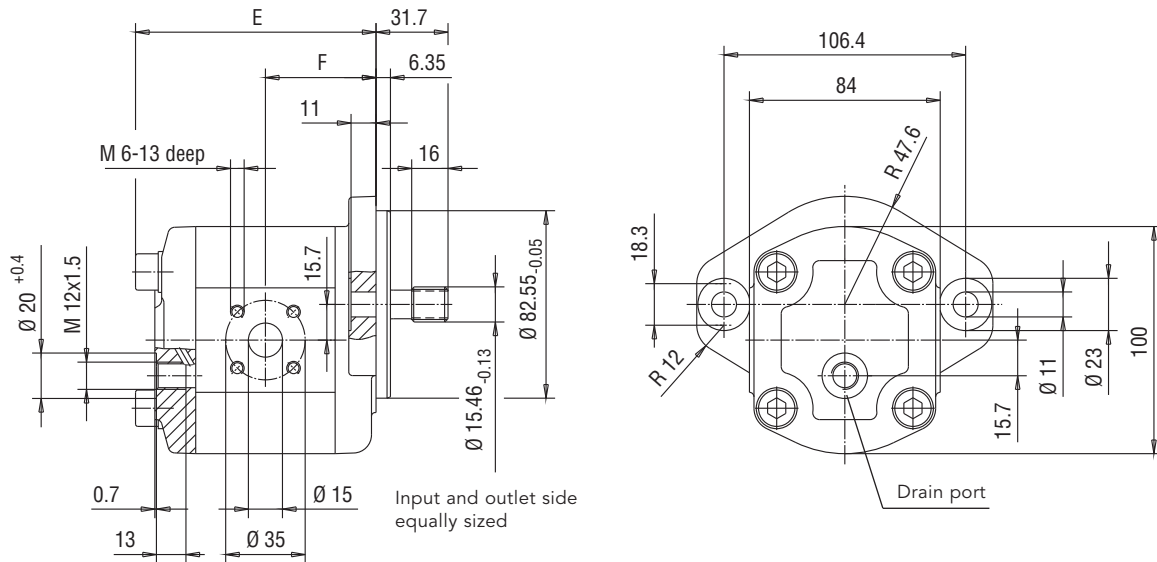

SAE A-Flange, Involute Spline Shaft End

Ordering example:

KM 1/8 A30A X0A 4NL1

Shaft end: involute spline
B 17 x 14 DIN 5482

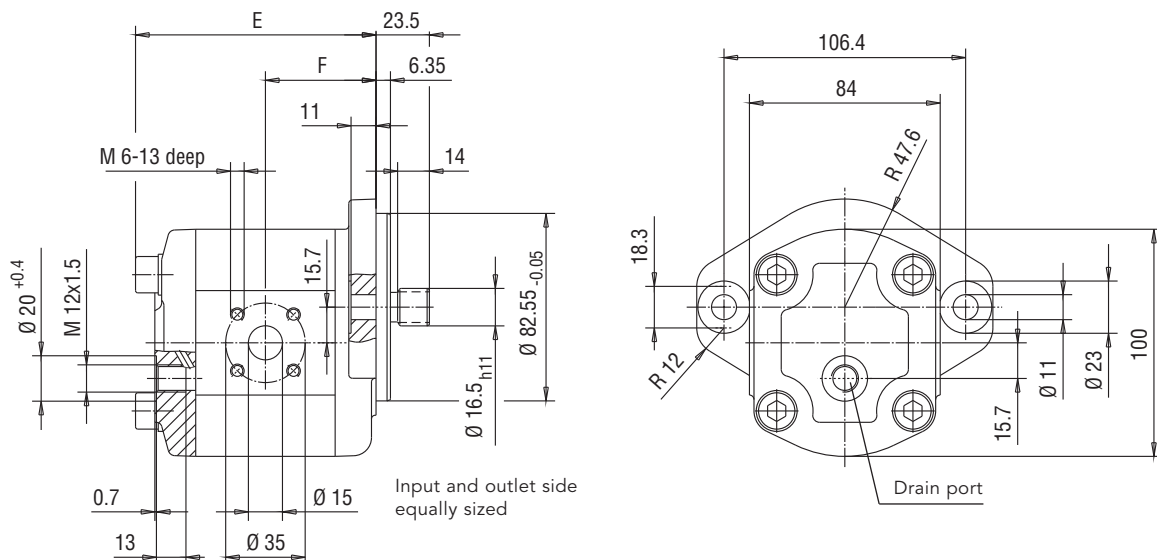

Displacement Nominal size	5.5	6.3	8	9.6	11	14	16	19	22	25
E	91.7	93.1	95.9	98.7	100.9	105.9	109.3	114.3	120.1	125.3
F	41.6	42.3	43.7	45.1	46.2	48.7	50.4	52.9	55.8	58.4
Weight kg	2.6	2.7	2.7	2.8	2.9	3.0	3.2	3.3	3.5	3.7

K-Flange, Tapered Shaft End 1 : 8

Ordering example:

KM 1/8 K30Q M0A 4NL1

Shaft end: taper 1: 8

Hex. lock nut M 12 x 1.5

EN ISO 8675

Curved spring washer B12

DIN 137

Woodruff key 3 x 6.5 DIN 6888

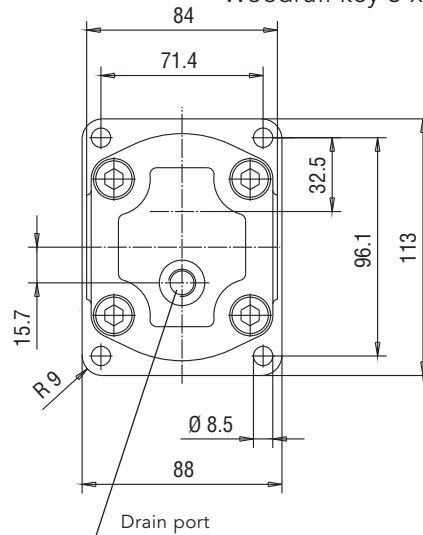
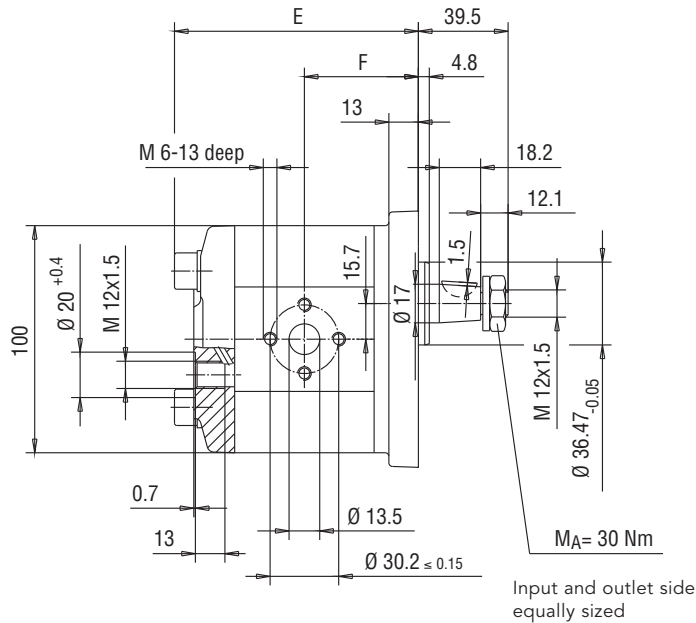

K-Flange, Involute Spline Shaft End

Ordering example:

KM 1/8 K30Q X0A 4NL1

Shaft end: involute spline

B 17 x 14 DIN 5482

but tooth thickness $S_w = 3.206$

Addendum modification = +0.6

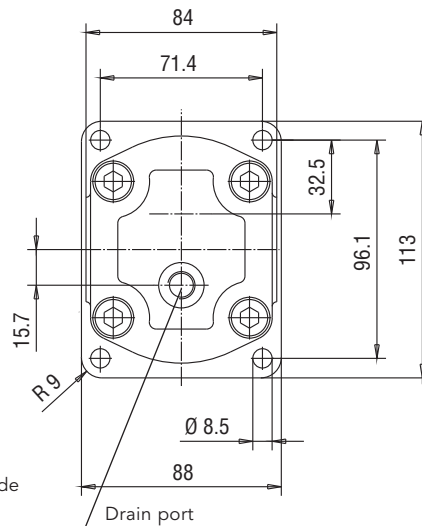
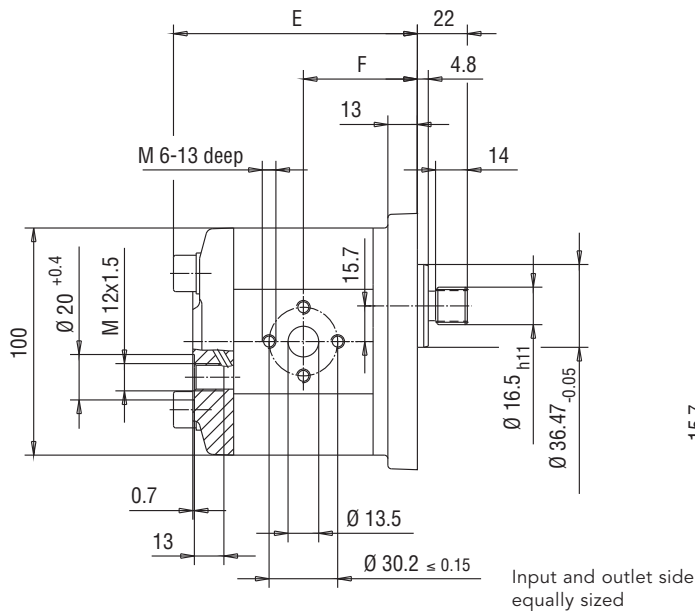

Displacement Nominal size	5.5	6.3	8	9.6	11	14	16	19	22	25
E	93.2	94.6	97.4	100.2	102.4	107.4	110.8	115.8	121.6	126.8
F	43.1	43.8	45.2	46.6	47.7	50.2	51.9	54.4	57.3	59.9
Weight kg	2.2	2.3	2.3	2.4	2.5	2.6	2.8	2.9	3.1	3.3

L-Flange, Parallel Flat Shaft End, without Shaft Lip-Type Seal

Ordering example:

KM 1/8 L30A F0A 4NL1

allowed torque $M_{max} = 40 \text{ Nm}$

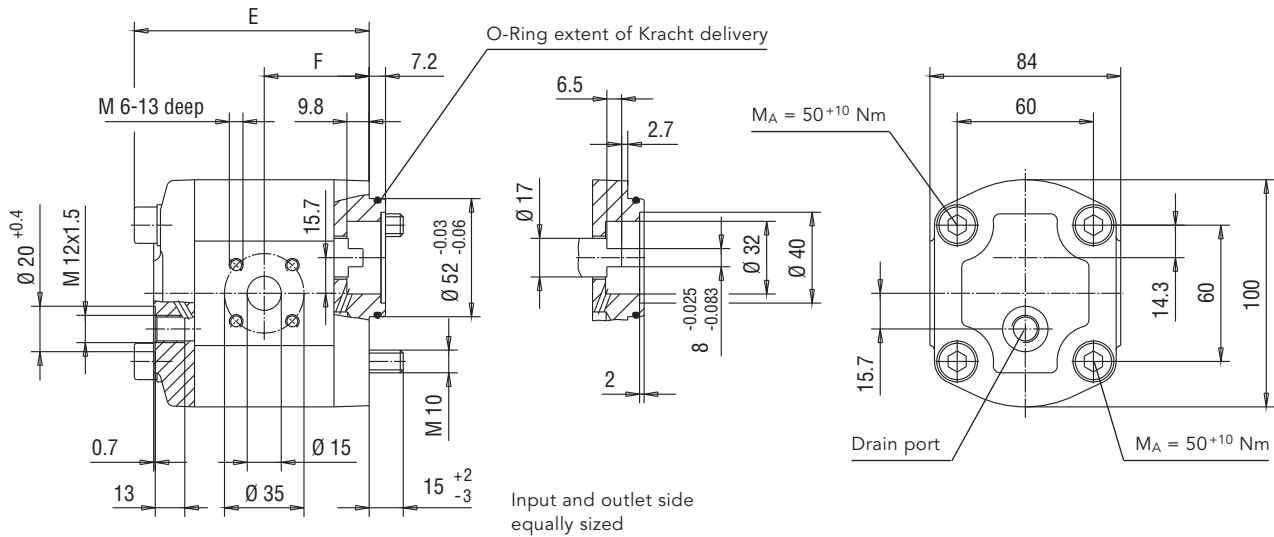

L-Flange, Involute Spline Shaft End, without Shaft Lip-Type Seal

Ordering example:

KM 1/8 L30A X0A 4NL1/204

Shaft end: involute spline
 B 17 x 14 DIN 5482
 but tooth thickness $S_w = 3.206$
 Addendum modification = +0.6

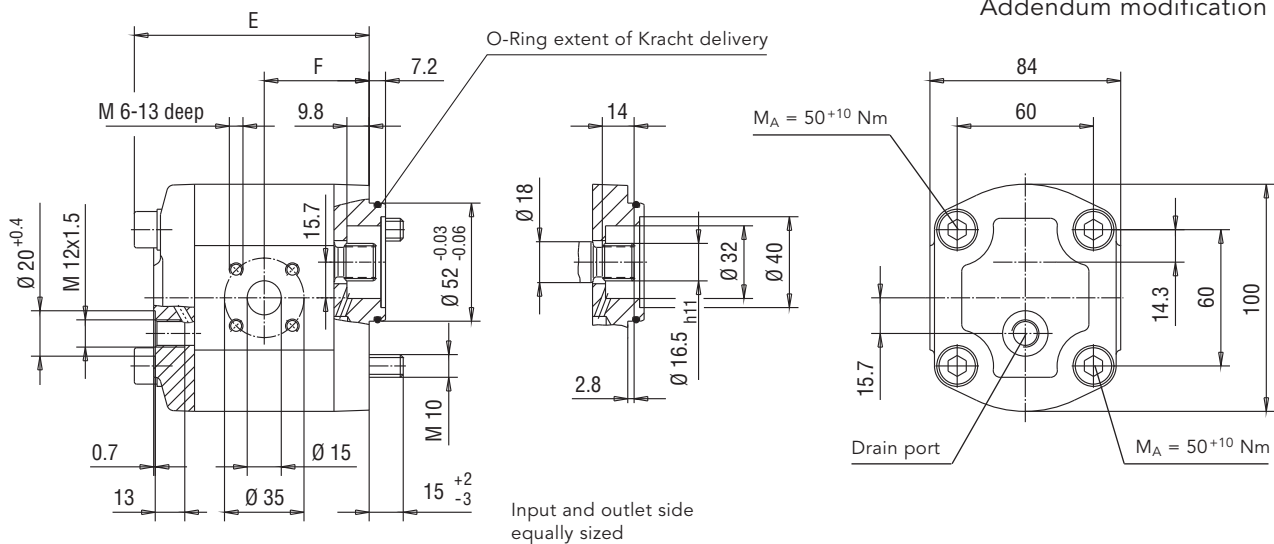

Displacement Nominal size	5.5	6.3	8	9.6	11	14	16	19	22	25
E	89.2	90.6	93.4	96.2	98.4	103.4	106.8	111.8	117.6	122.8
F	39.1	39.8	41.2	42.6	43.7	46.2	47.9	50.4	53.3	55.9
Weight kg	2.2	2.3	2.3	2.4	2.5	2.6	2.8	2.9	3.1	3.3

Outboard Bearing L, G-Flange, Tapered Shaft End Ø 20 mm

Ordering example:

KM 1/8 L3LA_X^F0A 4NL1

Shaft end: taper 1:5
 Hex. lock nut BM 14 x 1.5
 EN ISO 8675
 Curved spring washer B14 DIN 127
 Woodruff key 4 x 6.5 DIN 6888

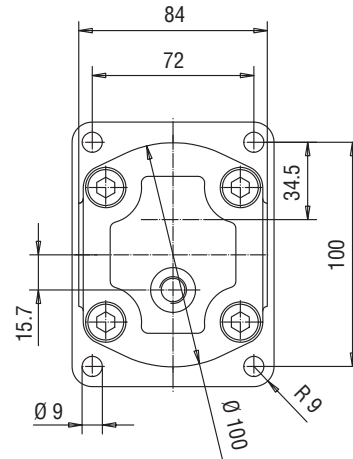
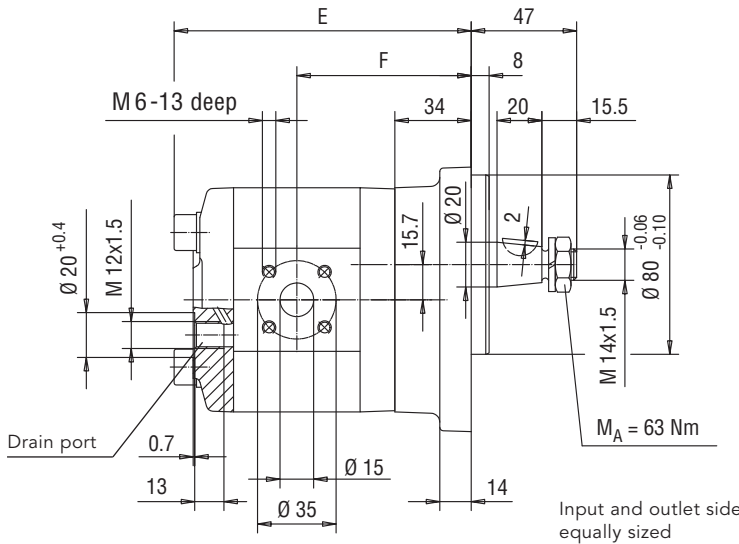

Outboard Bearing L, G-Flange, Tapered Shaft End Ø 17 mm

Ordering example:

KM 1/8 L3LA_X^F0A 4NL1/324

Shaft end: taper 1:5
 Hex. lock nut BM 12 x 1.5
 EN ISO 8675
 Curved spring washer B12 DIN 137
 Woodruff key 3 x 6.5 DIN 6888

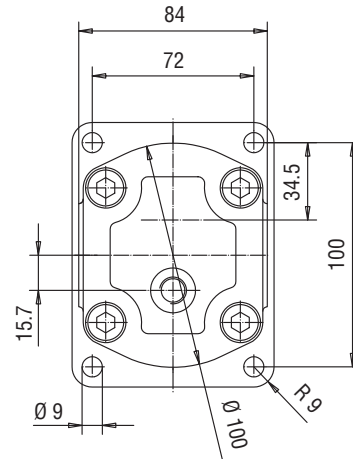
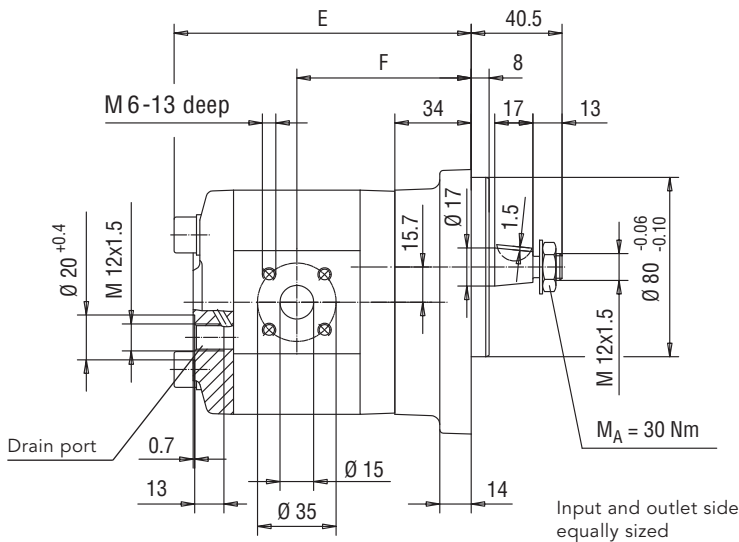

Displacement Nominal size	5.5	6.3	8	9.6	11	14	16	19	22	25
E	123.2	124.6	127.4	130.2	132.4	137.4	140.8	145.8	151.6	156.8
F	73.1	73.8	75.2	76.6	77.7	80.2	81.9	84.4	87.3	89.9
Weight kg	3.2	3.3	3.3	3.4	3.5	3.6	3.8	3.9	4.1	4.3

Outboard Bearing L, F-Flange, Tapered Shaft End Ø 17 mm

Ordering example:

KM 1/8 L3LA_XF_{0A} 4NL1/375

Shaft end: taper 1:5
Hex. lock nut BM 12 x 1.5
EN ISO 8675
Curved spring washer B12
DIN 137
Woodruff key 3 x 6.5
DIN 6888

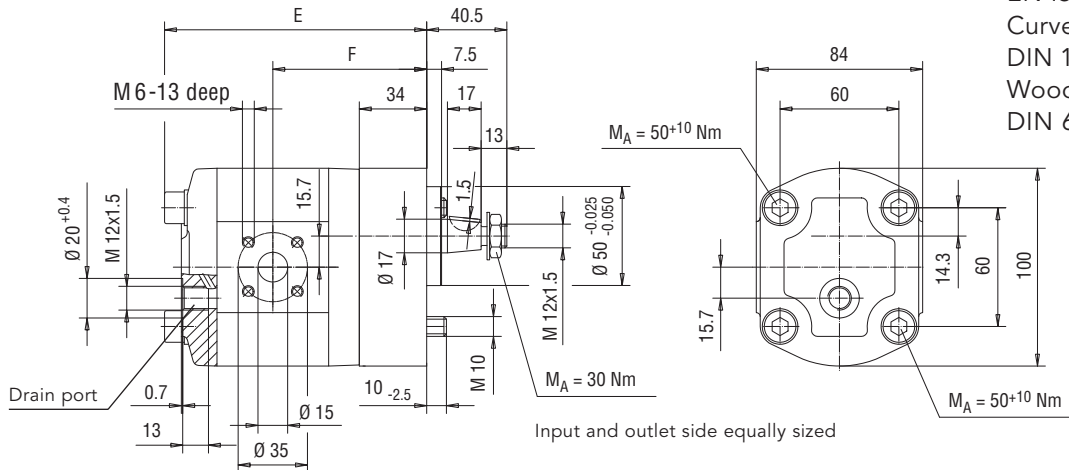

Displacement Nominal size	5.5	6.3	8	9.6	11	14	16	19	22	25
E	125.7	127.1	127.4	130.2	132.4	137.4	140.8	145.8	151.6	156.8
F	73.1	73.8	75.2	76.6	77.7	80.2	81.9	84.4	87.3	89.9
Weight kg	3.1	3.2	3.2	3.3	3.4	3.5	3.7	3.8	4.0	4.2

Outboard Bearing L, A-Flange, Tapered Shaft End Ø 20 mm

Ordering example:

KM 1/8 L3LA_XF_{0A} 4NL1/401

Shaft end: taper 1:5
Hex. lock nut BM 12 x 1.5
EN ISO 8675
Curved spring washer B12
DIN 137
Woodruff key 3 x 6.5
DIN 6888

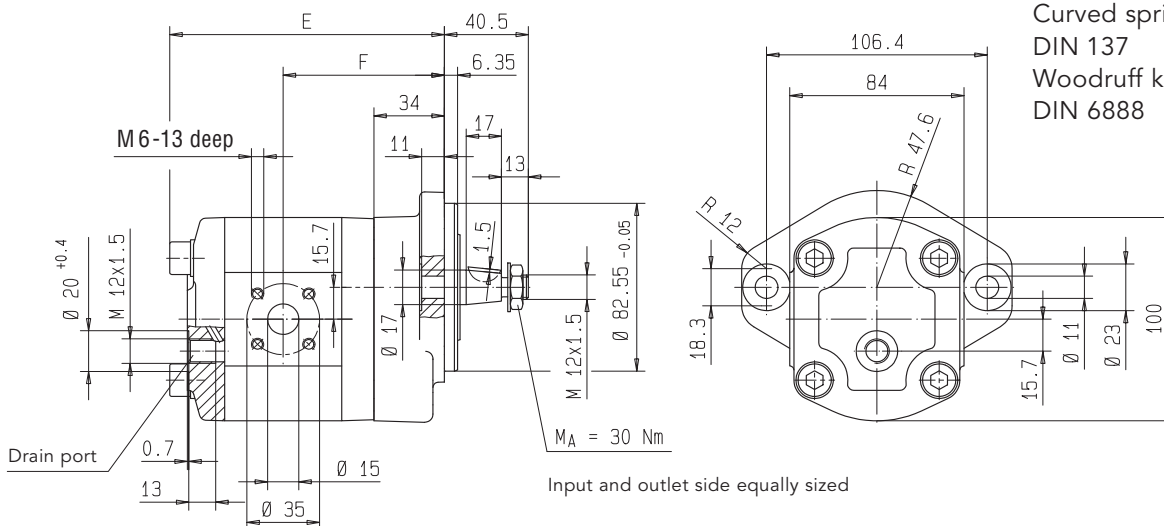

Displacement Nominal size	5.5	6.3	8	9.6	11	14	16	19	22	25
E	123.2	124.6	127.4	130.2	132.4	137.4	140.8	145.8	151.6	156.8
F	73.1	73.8	75.2	76.6	77.7	80.2	81.9	84.4	87.3	89.9
Weight kg	4.1	4.2	4.2	4.3	4.4	4.5	4.7	4.8	5.0	5.2

Permissible Load – Outboard Bearing L, Tapered Shaft End

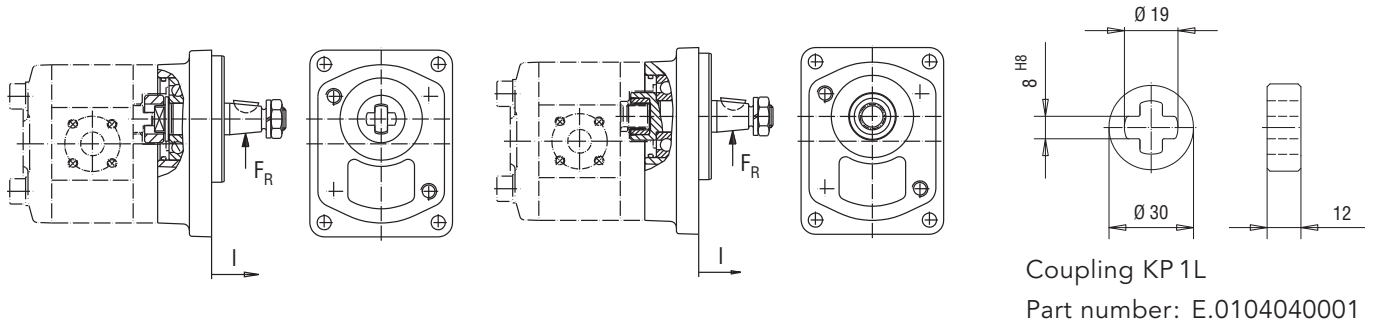

Permissible radial load $F_{R \max}$ as function of the supporting distance l for a given axial force F_A (for $L_h = 10,000$ h), medium wave at $l = 21.5$ mm

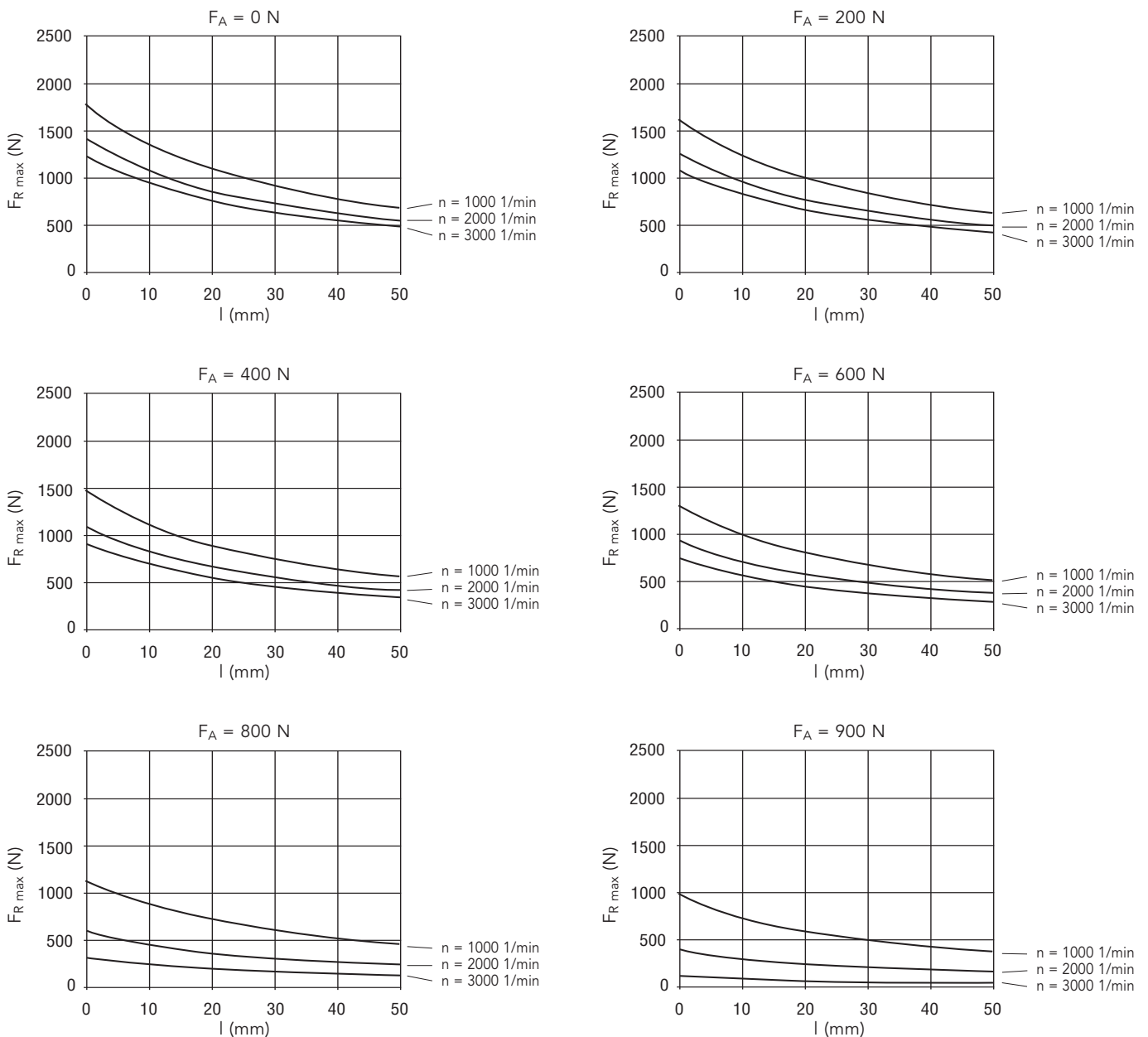

Permissible Load – Outboard Bearing P, Tapered Shaft End

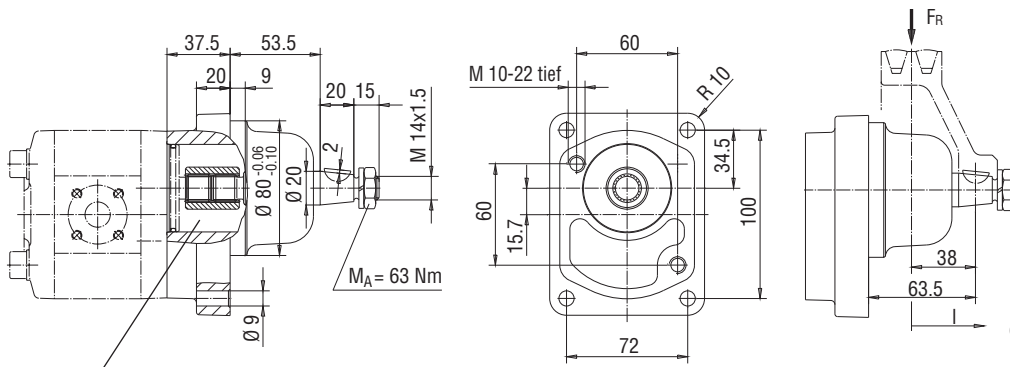

Shaft end: taper 1:5
 Hex. lock nut M 14 x 1.5
 Curved spring washer B 14
 Woodruff key 4 x 6.5
 Weight of the outboard bearing 3.5 kg

Ordering example:

KM 1/8 Q3PA X0A 4NL1

Fill with 50 cm³ oil (ISO VG 10 - 68) before assembly.

Permissible radial load $F_{R\max}$ as function of the supporting distance l for a given axial force F_A (for $L_h = 10,000$ h), medium wave at $l = 38$ mm

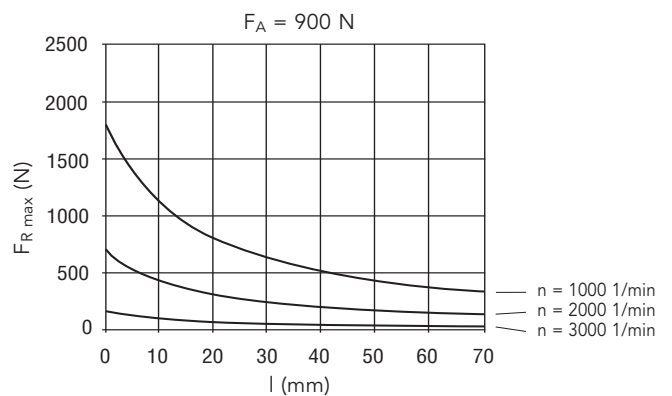
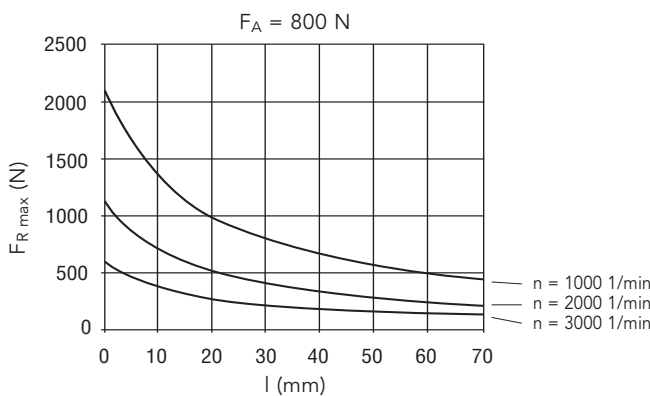
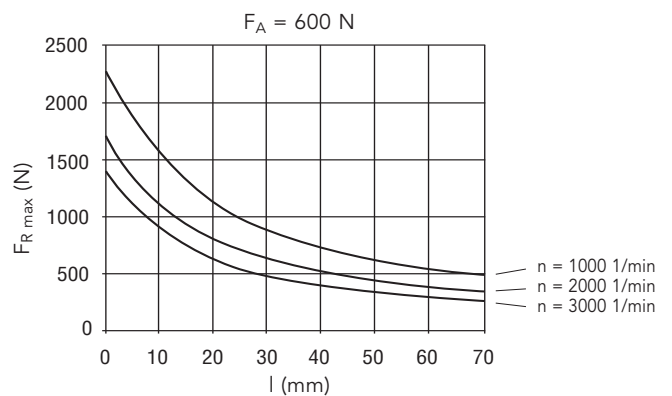
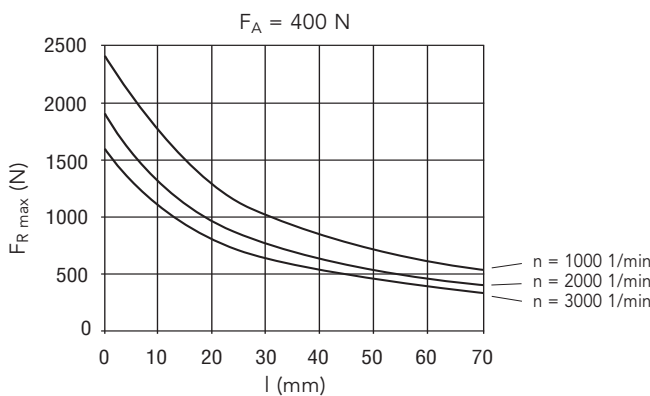
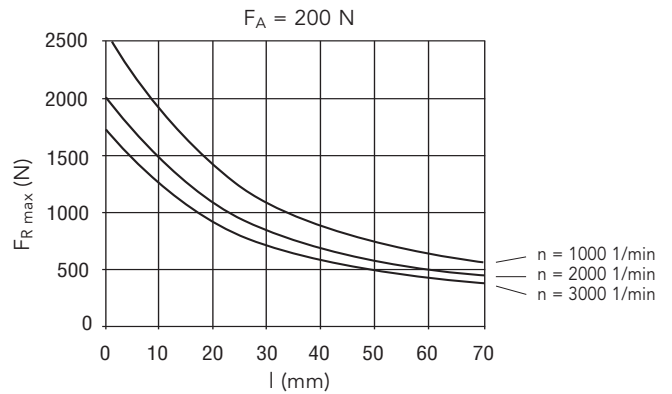
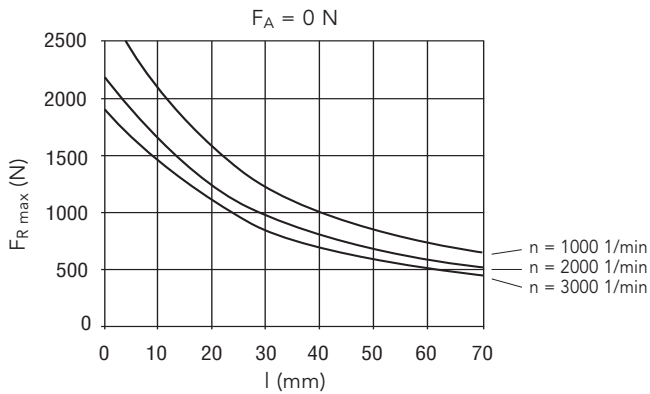

Mounting Angle, Tapered Shaft End

Ordering example:

KM 1/8 F3RA K0A 4NL1

Shaft end: taper 1:5
 Hex. lock nut M 12 x 1.5
 EN ISO 8675
 Curved spring washer B12
 DIN 137
 Woodruff key 3 x 6.5
 DIN 6888

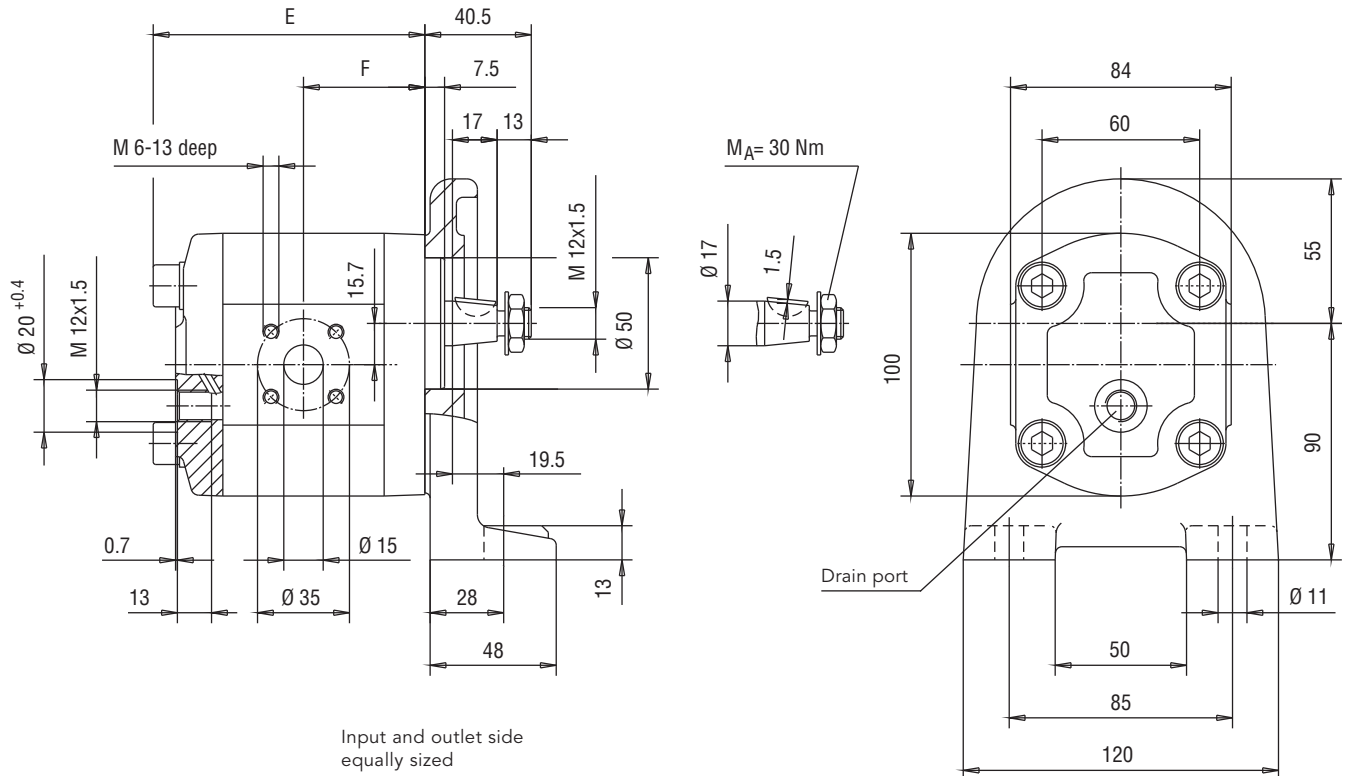

Displacement Nominal size	5.5	6.3	8	9.6	11	14	16	19	22	25
E	89.2	90.6	93.4	96.2	98.4	103.4	106.8	111.8	117.6	122.8
F	39.1	39.8	41.2	42.6	43.7	46.2	47.9	50.4	53.3	55.9
Weight kg	3.8	3.9	3.9	4.0	4.1	4.2	4.4	4.5	4.7	4.9

Double Type, Tapered Shaft End

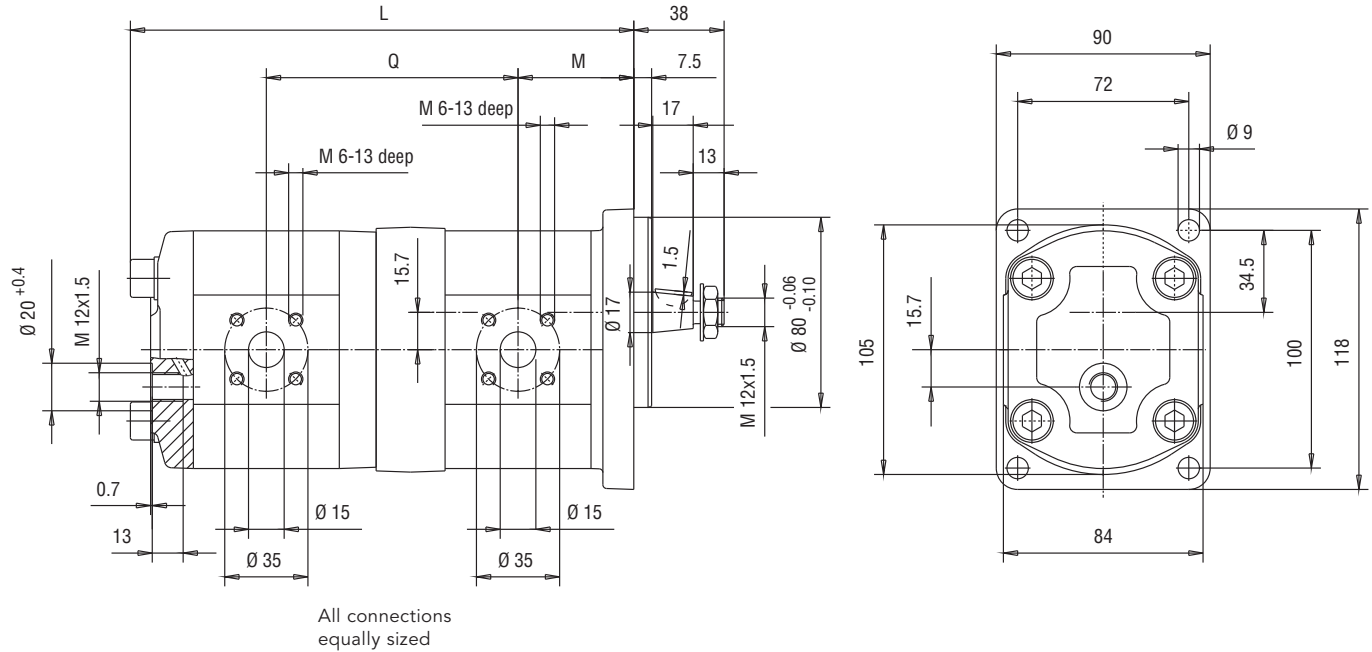

Example

Other flanges and shaft ends possible/available

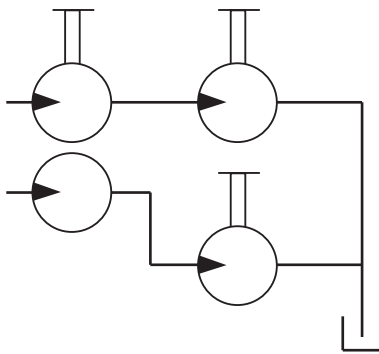

Ordering example:

**KM 1/8 G30A XXF 4NL1/215 +
KM 1/8 L30A X0A 4NL1/215**

Nominal displacement	Nominal displacement																					
	M		d		1. Stage																	
					25		22		19		16		14		11		8		6.3		5.5	
				Q	L	Q	L	Q	L	Q	L	Q	L	Q	L	Q	L	Q	L			
5.5	41.6	15	2. Stage	5.5	108.5	217.0	105.9	211.8	103.0	206.0	100.5	201.0	98.8	197.6	96.3	192.6	93.8	187.6	92.4	184.8	91.7	183.4
6.3	42.3	20		6.3	109.2	218.4	106.6	213.2	103.7	207.4	101.2	202.4	99.5	199.0	97.0	194.0	94.5	189.0	93.1	186.2		
8	43.7	20		8	110.6	221.2	108.0	216.0	105.1	210.2	102.6	205.2	100.9	201.8	98.4	196.8	95.9	191.8				
11	46.2	20		11	113.1	226.2	110.5	221.0	107.6	215.2	105.1	210.2	103.4	206.8	100.9	201.8						
14	48.7	20		14	115.6	231.2	113.0	226.0	110.1	220.2	107.6	215.2	105.9	211.8								
16	50.4	20		16	117.3	234.6	114.7	229.4	111.8	223.6	109.3	218.6										
19	52.9	20		19	119.8	239.6	117.2	234.4	114.3	228.6												
22	55.8	20		22	122.7	245.4	120.1	240.2														
25	58.4	20		25	125.3	250.6																

Flow Divider KM 1

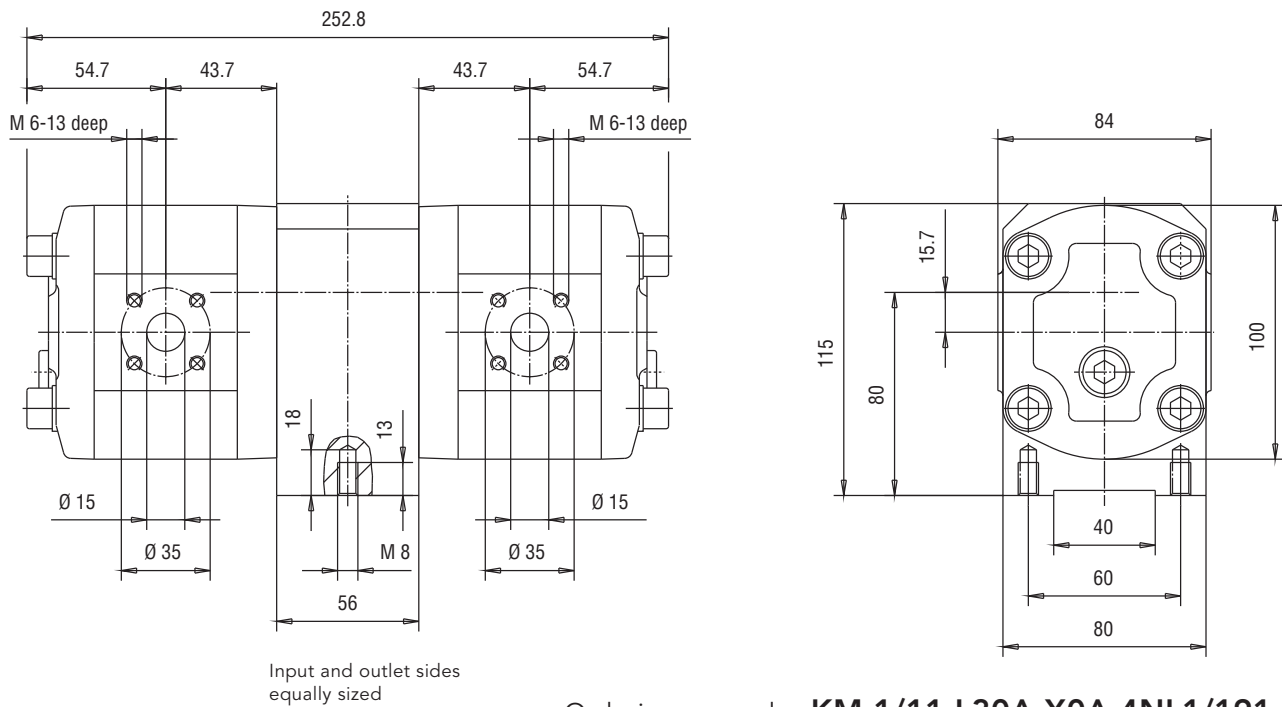
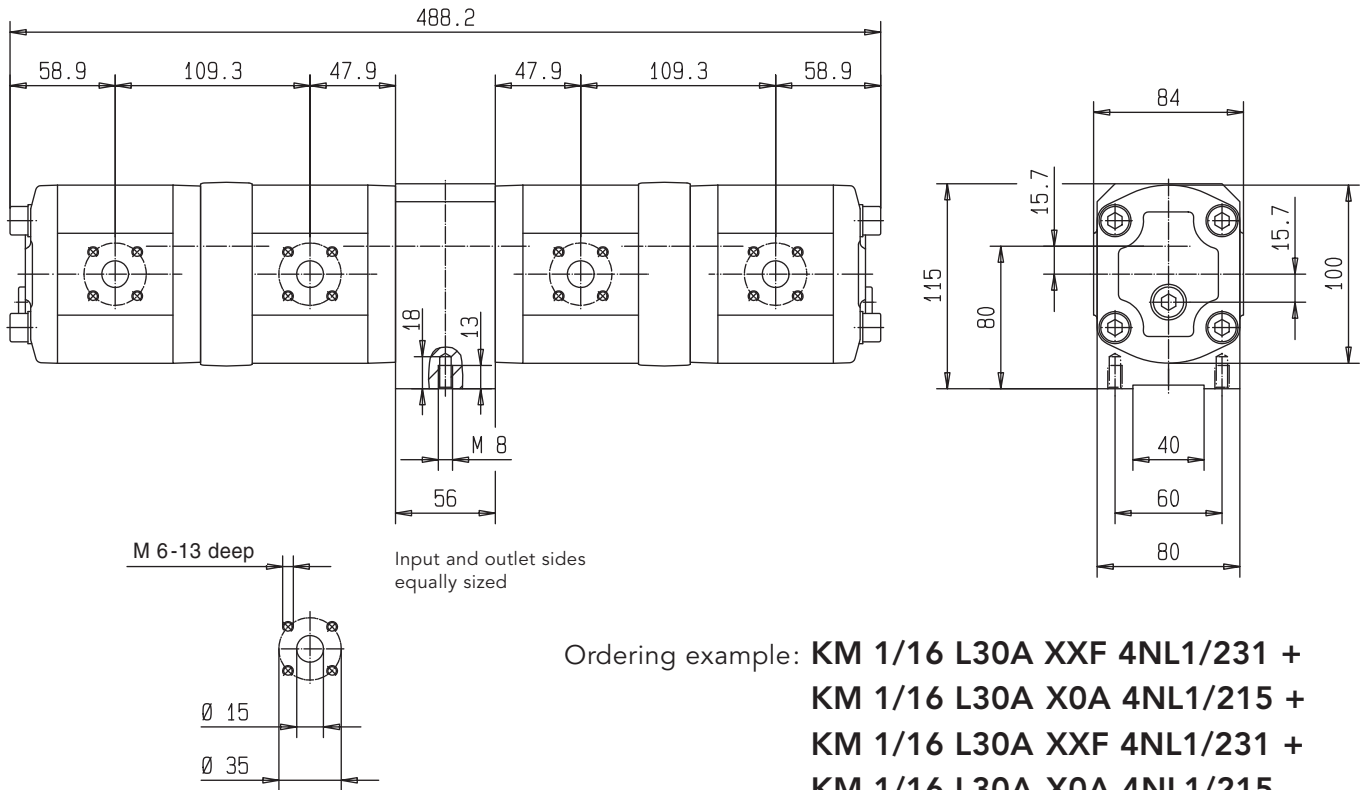

Coupling and Accessories

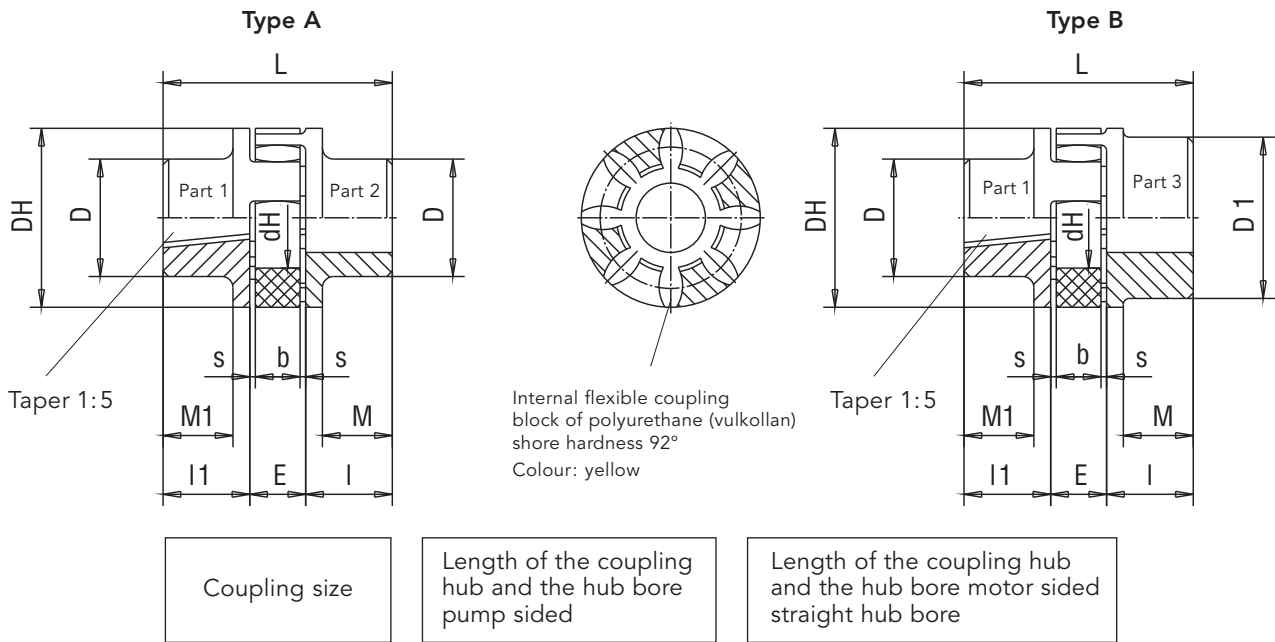

Ordering example: **RA 38 - K 18/17 - Z 45/38**

	Coupling size	Weight kg	Moment of inertia kgm ²	Rough bore		Finished bore				Dimensions								Ordering code				
				Part 2	Part 3	min. Part 2	min. Part 3	max. Part 2	max. Part 3	I	I ₁	E	s	b	L	M	M ₁		D _H	D	D ₁	d _H
Type A	24	0.2	0.00008	-	-	9	-	24	-	30	18.5	18	2	14	66.5	24	12.5	55	40	-	27	RA 24-K18/17-Z 30/...
	28	0.35	0.0002	-	-	10	-	28	-	35	18.5	20	2.5	15	73.5	28	11.5	65	48	-	30	RA 28-K18/17-Z 35/...
	38	0.75	0.0007	-	-	12	-	38	-	45	18.5	24	3	18	87.5	37	10.5	80	66	-	38	RA 38-K18/17-Z 45/...
	42	1.15	0.0014	25	-	28	-	42	-	50	18.5	26	3	20	94.5	40	8.5	95	75	-	46	RA 42-K18/17-Z 50/...
Type B	24/28	0.22	0.0001	-	20	-	22	-	28	30	18.5	18	2	14	66.5	24	12.5	55	40	56	27	RA 24/28-K18/17-Z 30/...
	28/38	0.42	0.0003	-	23	-	28	-	38	35	18.5	20	2.5	15	73.5	28	11.5	65	48	67	30	RA 28/38-K18/17-Z 35/...
	38/45	0.82	0.0008	-	36	-	38	-	45	45	18.5	24	3	18	87.5	37	10.5	80	66	77	38	RA 38/45-K18/17-Z 45/...
	38/45	2.5	0.0020	-	-	-	38	-	45	70	18.5	24	3	18	112.5	62	10.5	80	66	78	38	RG 38/45-K18/17-Z 70/...
	42/55	1.29	0.0018	-	25	-	42	-	55	50	18.5	26	3	20	94.5	40	8.5	95	75	94	46	RG 42/55-K18/17-Z 50/...

Working temperatur: -40 °C to +90 °C (short time temperature peaks up to +120 °C are permissible)
 Weights as well as moments of inertia relate to the max. bore dia. after final machining – but without key-way.
 Bore finish acc. to ISO-fit class H7; key-ways acc. to DIN 6885 / part 1.

RA: Hub material Al
RG: Hub material part 2 and 3 GG

Coupling sleeve:

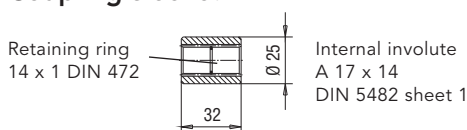

Coupling sleeve size 1
 Part number: B.0079020001

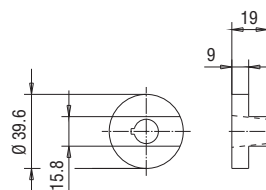

Coupling KP 1 k-shaft
 Partnumber: E.0187220001

Straight Flanged Connector

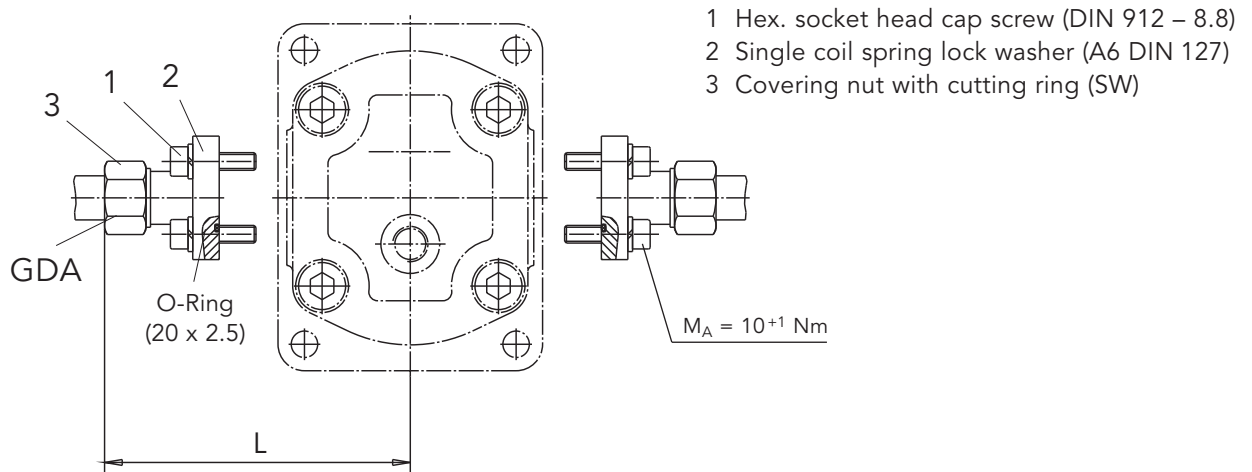

- 1 Hex. socket head cap screw (DIN 912 – 8.8)
- 2 Single coil spring lock washer (A6 DIN 127)
- 3 Covering nut with cutting ring (SW)

Inlet port pipe externa dia. mm	Ordering code	Rated pressure P_N in bar	Dimensions		Cap screw	Weight kg
			L	SW		
16	GDA 1/16	315	82	30	4 x M6 x 22	0.18
15	GDA 1/15	250	81	27	4 x M6 x 22	0.17
12	GDA 1/12	315	81	22	4 x M6 x 22	0.16

Elbow Flanged Connector

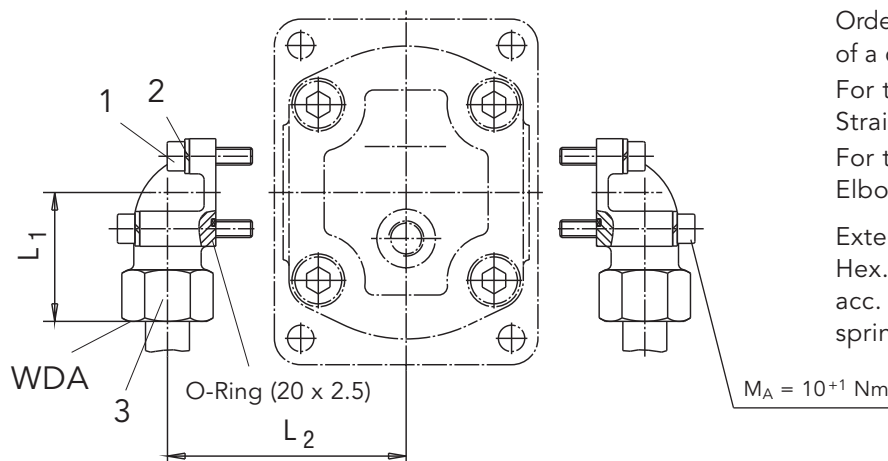

Ordering example
of a complete connection:
For the inlet port:
Straight flanged connector **GDA 1/22**
For the outlet port:
Elbow flanged connector **WDA 1/20**
Extend of Kracht delivery:
Hex. socket head cap screw
acc. to DIN 912 as well as single coil
spring lock washers and O-rings.

Inlet port pipe externa dia. mm	Ordering code	Rated pressure P_N in bar	Dimensions			Cap screw	Weight kg
			L ₁	L ₂	SW		
20	WDA 1/20	315	56	67	36	2 x M6 x 45 2 x M6 x 22	0.40
16	WDA 1/16	315	48	62	30	2 x M6 x 40 2 x M6 x 22	0.28
15	WDA 1/15	250	46	58.5	27	2 x M6 x 35 2 x M6 x 22	0.22
12	WDA 1/12	315	47	58.5	22	2 x M6 x 35 2 x M6 x 22	0.20

Note

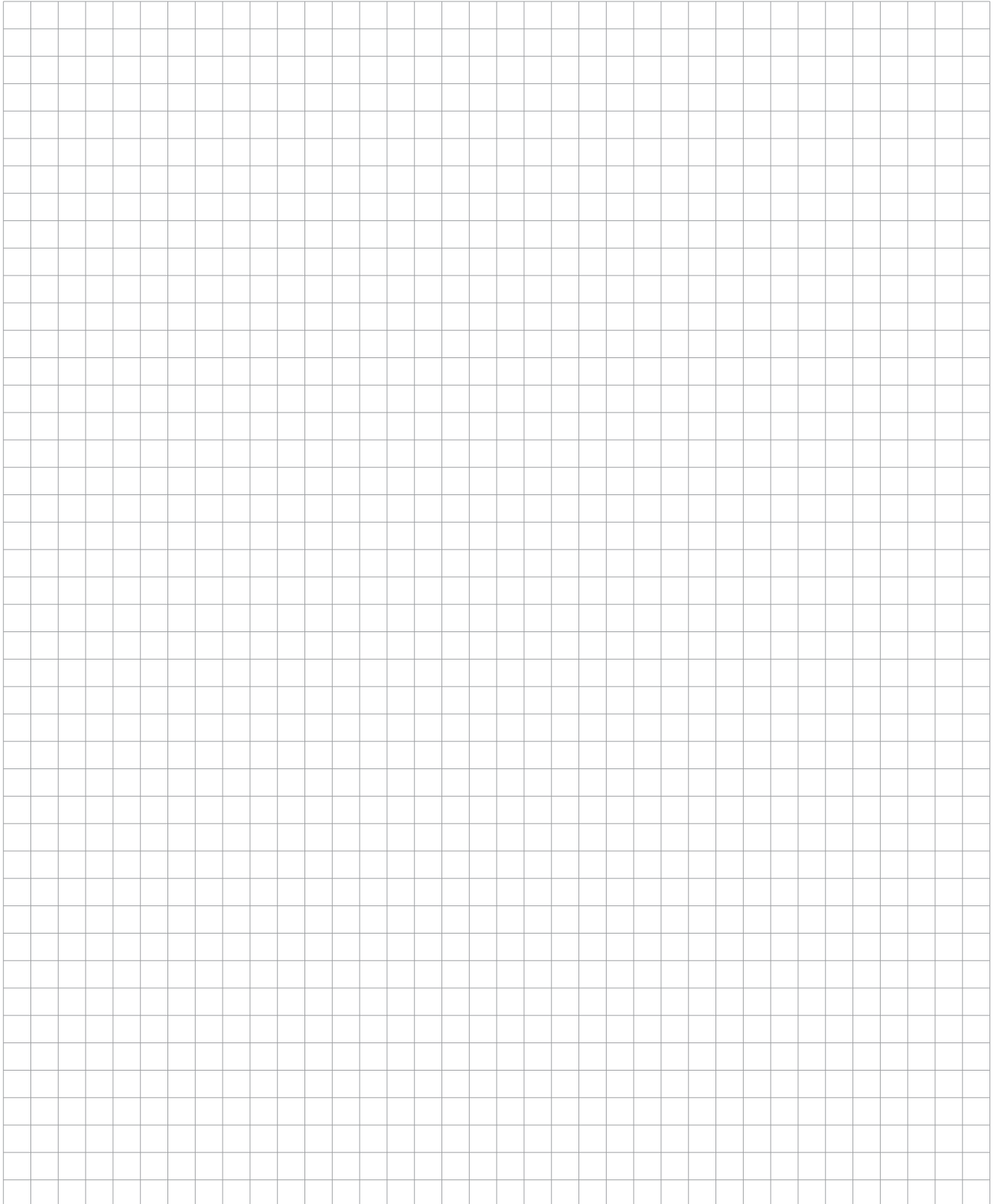

Product Portfolio

Transfer Pumps

Transfer pumps for lubricating oil supply equipment, low pressure filling and feed systems, dosing and mixing systems.

Mobile Hydraulics

Single and multistage high pressure gear pumps, hydraulic motors and valves for construction machinery, vehicle-mounted machines.

Flow Measurement

Gear and turbine flow meters and electronics for volume and flow metering technology in hydraulics, processing and laquering technology.

Industrial Hydraulics / Test Bench Construction

Cetop directional control and proportional valves, hydraulic cylinders, pressure, quantity and stop valves for pipe and slab construction, hydraulic accessories for industrial hydraulics (mobile and stationary use).

Technology Test benches / Fluid Test benches.



KM 1/GB/02.14

KRACHT