

OWC-30-DE-2VMP-14

VALVOLA BILANCIAMENTO, BLOCCO E CONTROLLO MOVIMENTO A DOPPIO EFFETTO, CON COLLETTORE IN LINEA E LIMITATRICE

DOUBLE COUNTERBALANCE VALVE WITH RELIEF VALVE AND IN LINE BODY

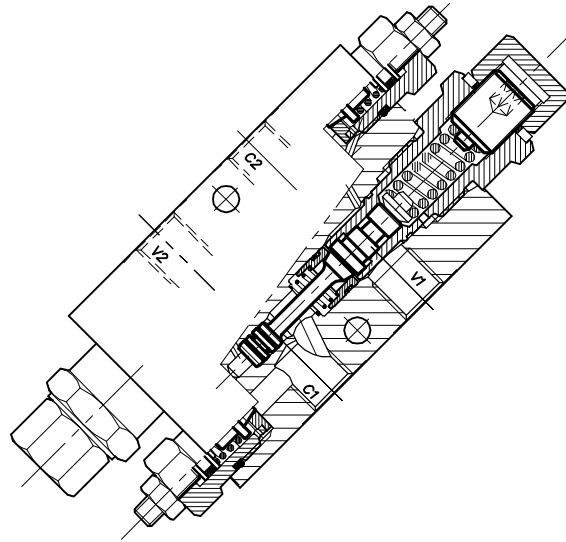
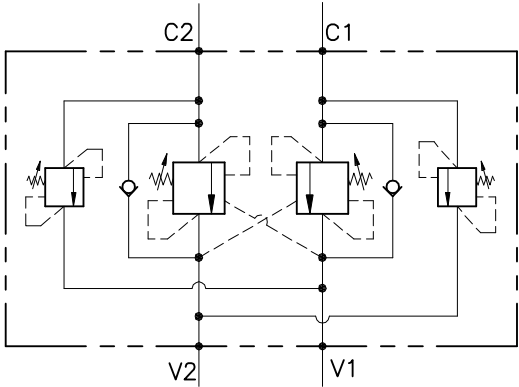

CARATTERISTICHE

Luce nominale	DN 6
Portata min/max	1/25 l/min - 0.26/6.6 GPM
Pressione di lavoro max.	350 bar - 5075 PSI
Pressione max. di taratura	350 bar - 5075 PSI
Rapporto di pilotaggio standard	4 : 1
Temperatura ambiente	-30°C + 50°C
Temperatura olio	-30°C + 80°C
Filtraggio consigliato	30 micron
Coppia di serraggio	76÷82 Nm
Peso	0.300 Kg

PERFORMANCE

Rated size
Min/max flow-rate
Max working pressure
Max setting pressure
Standard pilot ratio
Room temperature
Oil temperature
Recommended filtration
Tightening torque
Weight

NOTE:

La taratura deve essere **1.3** volte maggiore della pressione indotta dal carico.

Valve should be set at **1.3** times load induced pressure.

ESEMPIO/EXAMPLE:

Pressione di lavoro max:

Max working pressure:

350 bar / 1.3 = 270 bar

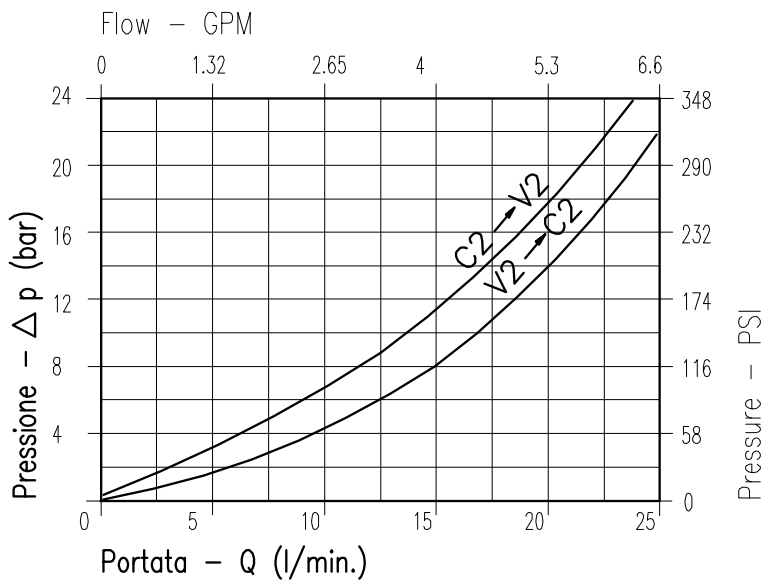

Viscosità olio 46 cSt a 50°C
Oil viscosity 46 cSt at 50°C

REGOLAZIONE
ADJUSTMENT

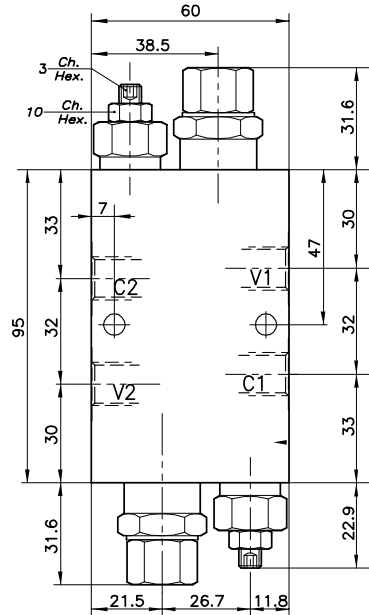

Grano
Dowel
(X)

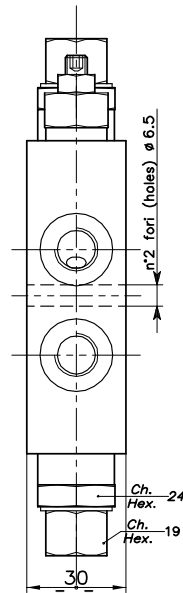

Piombata
Sealed
(H)

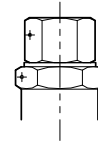

**DIMENSIONI
DIMENSIONS**

Campo taratura Setting range	Attacchi Port size V2-C2 V1-C1 GAS (BSPP)	Luce nominale Rated size DN	Portata max Max flow-rate l/min - GPM
628	1/4"	6	25-6

**ESEMPIO TIPICO DI CIRCUITO
TYPICAL CIRCUIT EXAMPLE**

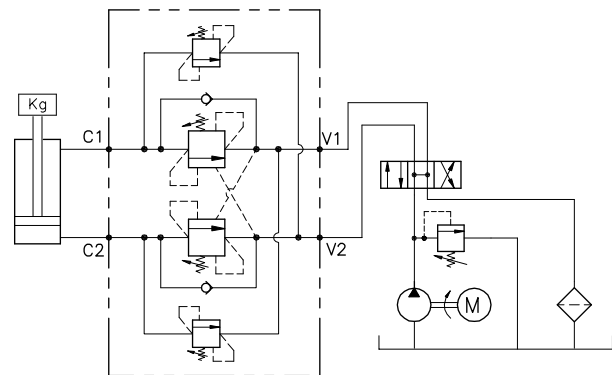

**CODICE DI ORDINAZIONE
HOW TO ORDER**

001 628 0 X 0

Campo taratura / Setting range

628

Campo taratura 30÷280 bar (molla colore verde)
Setting range 30÷280 bar (green spring)

Taratura standard (Q=5 l/1')
Std. bar setting (Q=5 l/1')
250 bar

Incr. press. - bar giro/vite
Pressure rise - bar/turn of screw
(56)

Rapporto di pilotaggio
Pilot ratios

O 4 : 1
F 7 : 1

Regolazione
Adjustment

X Grano - Dowel
H Piombata - Sealed