

OWC-SE-12-FMB-SH-...

VALVOLA BILANCIAMENTO, BLOCCO E CONTROLLO MOVIMENTO
A SEMPLICE EFFETTO FLANGIATA MOTORE

SINGLE COUNTERBALANCE MOTOR FLANGEABLE VALVE

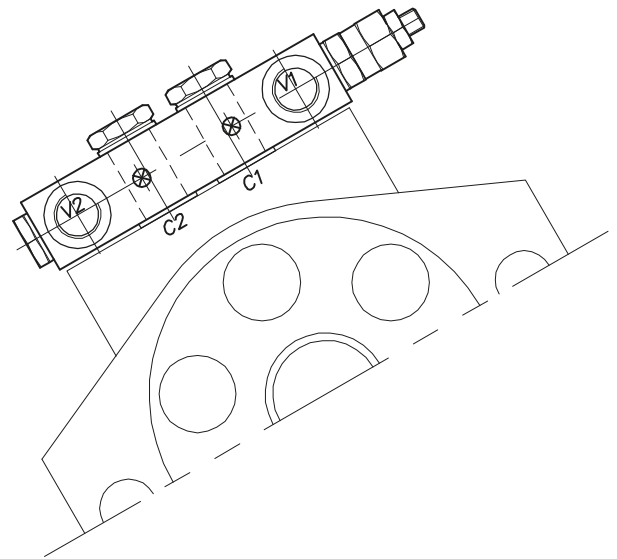
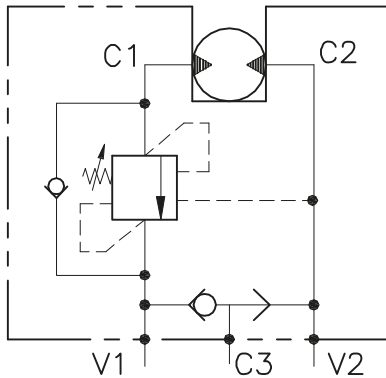

CARATTERISTICHE

Luce nominale	DN 10
Portata min/max	1/60 l/min - 0.26/15.9 GPM
Pressione di lavoro max.	350 bar - 5075 PSI
Pressione max. di taratura	350 bar - 5075 PSI
Rapporto di pilotaggio standard	4.25 : 1
Temperatura ambiente	-30°C + 50°C
Temperatura olio	-30°C + 80°C
Filtraggio consigliato	30 micron
Coppia di serraggio	110÷115 Nm
Peso	

PERFORMANCE

Rated size
Min/max flow-rate
Max working pressure
Max setting pressure
Standard pilot ratio
Room temperature
Oil temperature
Recommended filtration
Tightening torque
Weight

NOTE:

La taratura deve essere **1.3** volte maggiore della pressione indotta dal carico.

Valve should be set at **1.3** times load induced pressure.

ESEMPIO/EXAMPLE:

Pressione di lavoro max:

Max working pressure:

350 bar / 1.3 = 270 bar

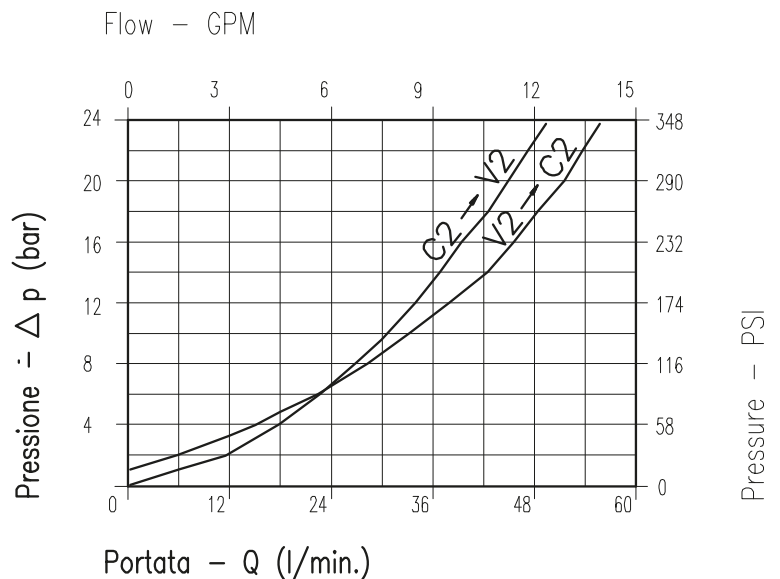

Viscosità olio 46 cSt a 50°C
Oil viscosity 46 cSt at 50°C

REGOLAZIONE
ADJUSTMENT →

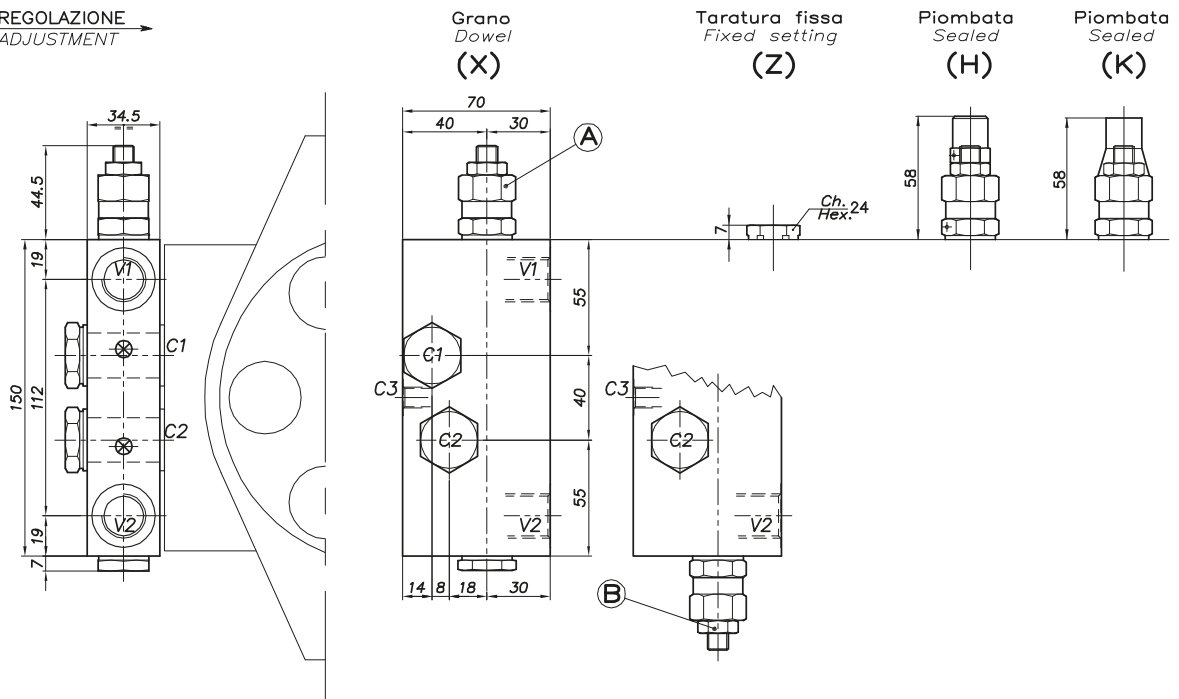

DIMENSIONI DIMENSIONS

Campo taratura Setting range	Attacchi Port size V2-C2 V1-C1 GAS (BSPF)	Attacchi Port size C3 GAS (BSPF)	Portata max Max flow-rate l/min - GPM
153	1/2"	1/8"	60-15,9

ESEMPIO TIPICO DI CIRCUITO TYPICAL CIRCUIT EXAMPLE

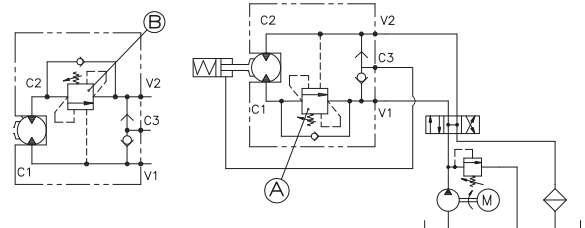

CODICE DI ORDINAZIONE HOW TO ORDER

007 153 A X 0

Campo taratura / Setting range	Porta controllata Controlled port	Regolazione Adjustment
153	A C1-V1 B C2-V2	X Grano - Dowel Z Taratura fissa - Fixed setting H Piombata - Sealed K Piombata - Sealed
Campo taratura 30÷220 bar (molla colore verde) Setting range 30÷220 bar (green spring)		
Taratura standard (Q=5 l/1') Std. bar setting (Q=5 l/1') 220 bar	Incr. press. - bar giro/vite Pressure rise - turn of screw (56)	