

# OWC-SE-...-14FCB-...

VALVOLA BILANCIAMENTO, BLOCCO E CONTROLLO MOVIMENTO A SEMPLICE EFFETTO CON COLLETTORE FLANGIATO

SINGLE COUNTERBALANCE VALVE WITH FLANGEABLE BODY

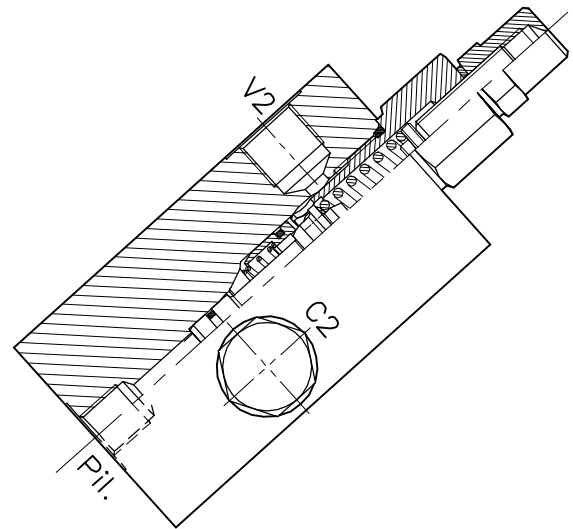
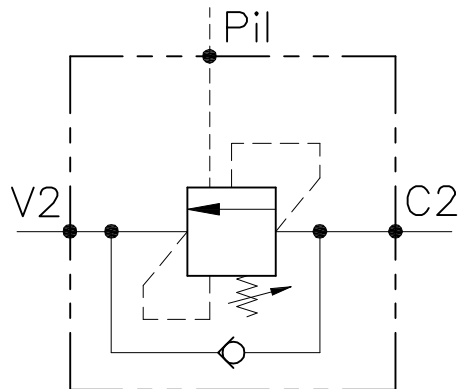

## CARATTERISTICHE

Luce nominale min/max	<b>DN 8</b>
Portata min/max	<b>1/60 l/min - 0.26/15.9 GPM</b>
Pressione di lavoro max.	<b>450 bar - 6525 PSI</b>
Pressione max. di taratura	<b>350 bar - 5075 PSI</b>
Rapporto di pilotaggio standard	<b>4.25 : 1</b>
Temperatura ambiente	<b>-30°C + 50°C</b>
Temperatura olio	<b>-30°C + 80°C</b>
Filtraggio consigliato	<b>30 micron</b>
Peso	

## PERFORMANCE

Min/max rated size
Min/max flow-rate
Max working pressure
Max setting pressure
Standard pilot ratio
Room temperature
Oil temperature
Recommended filtration
Weight

### NOTE:

La taratura deve essere **1.3** volte maggiore della pressione indotta dal carico.

Valve should be set at **1.3** times load induced pressure.

### ESEMPIO/EXAMPLE:

Pressione di lavoro max:

Max working pressure:

**350 bar / 1.3 = 270 bar**

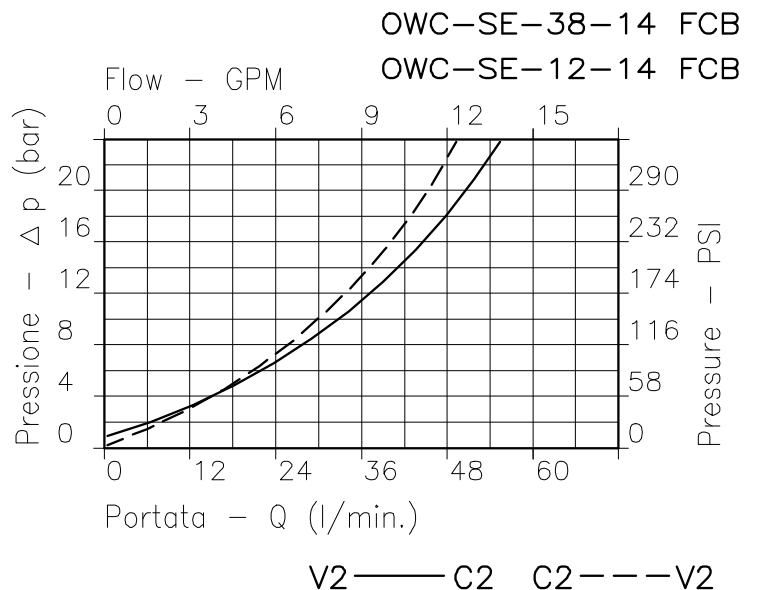

Viscosità olio 46 cSt a 50°C  
Oil viscosity 46 cSt at 50°C

REGOLAZIONE  
ADJUSTMENT →

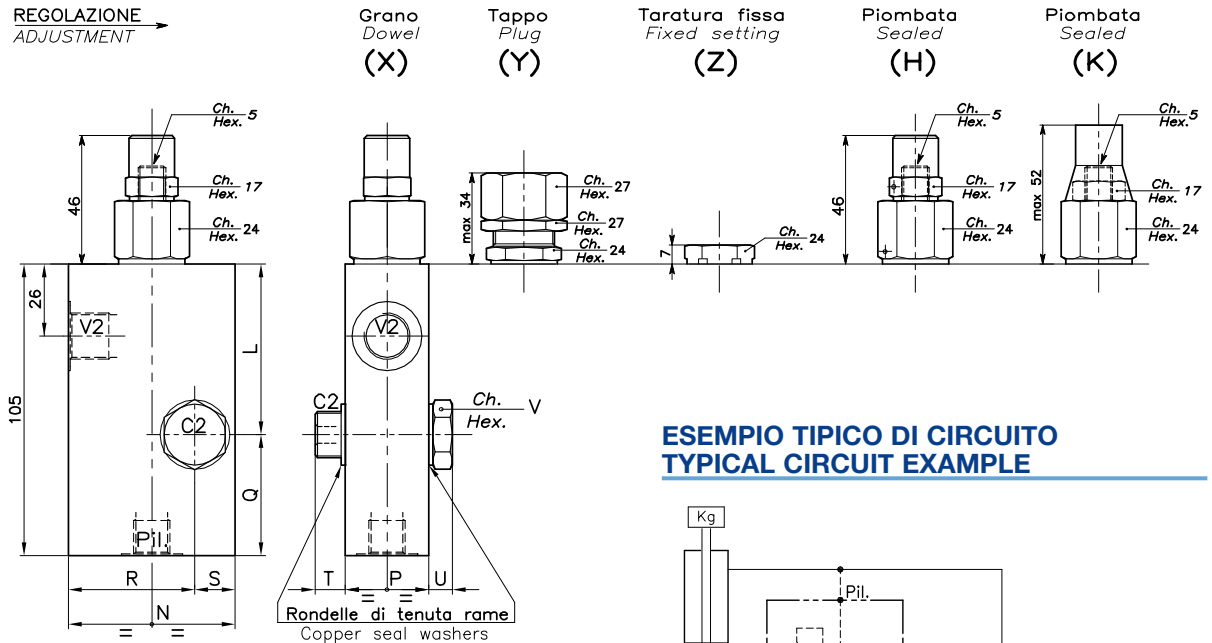

## ESEMPIO TIPICO DI CIRCUITO TYPICAL CIRCUIT EXAMPLE

## DIMENSIONI DIMENSIONS

Campo taratura Setting range		L	N	P	Q	R	S	T	U	V	Attacchi Port size V2-C2 GAS (BSPP)	Attacchi Port size PIL GAS (BSPP)	Portata max Max flow-rate l/min - GPM
071	024	61,5	60	29,5	43,5	46	14	12	8	22	3/8"	1/4"	40-10
073	030	63	70	34,5	42	55	15	12	8	27	1/2"	1/4"	60-15

## CODICE DI ORDINAZIONE HOW TO ORDER

001 071 0 X 0

Campo taratura / Setting range				Rapporto di pilotaggio Pilot ratios		Regolazione Adjustment	
071		024		O 4.25 : 1		X Grano - Dowel	
073		030		D 8 : 1		Y Tappo - Plug	
Campo taratura 30÷220 bar (molla olore verde) Setting range 30÷220 bar (green spring)		Campo taratura 60÷350 bar (molla colore giallo) Setting range 60÷350 bar (yellow spring)				Z Taratura fissa - Fixed setting	
Taratura standard (Q=5 l/1')	Incr. press. - bar giro/vite	Taratura standard (Q=5 l/1')	Incr. press. - bar giro/vite			H Piombata - Sealed	
Std. bar setting (Q=5 l/1')	Pressure rise - turn of screw	Std. bar setting (Q=5 l/1')	Pressure rise - turn of screw			K Piombata - Sealed	
210 bar	(56)	350 bar	(138)				