

VMP-10-...

VALVOLA DI MASSIMA PRESSIONE A CARTUCCIA AD AZIONE DIRETTA CON OTTURATORE CONICO

CARTRIDGE RELIEF, DIRECT ACTING POPPET TYPE VALVE

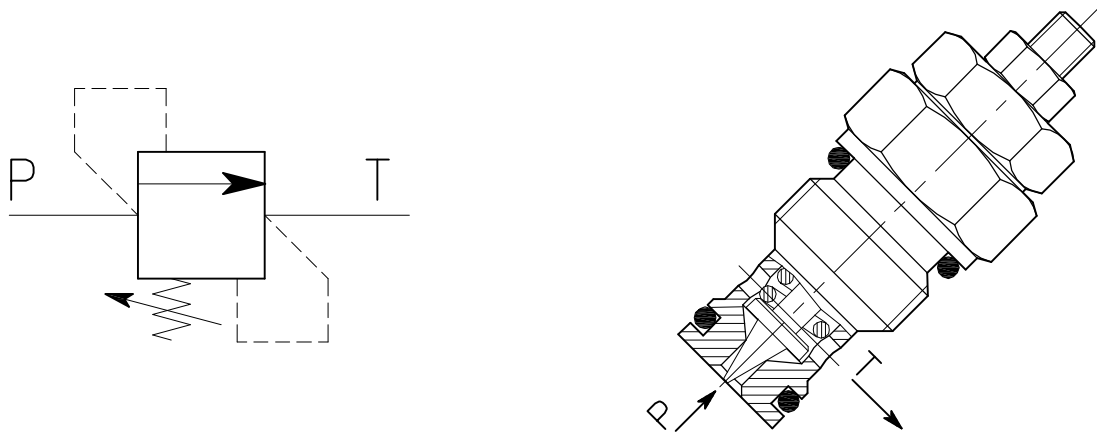

CARATTERISTICHE

Luce nominale	DN 4
Portata min/max	10 l/min - 2.6 GPM
Pressione di lavoro max.	350 bar - 5075 PSI
Pressione max. di taratura	350 bar - 5075 PSI
Temperatura ambiente	-30°C + 50°C
Temperatura olio	-30°C + 80°C
Filtraggio consigliato	30÷50 micron
Coppia di serraggio	46÷52 Nm
Peso	0.095 kg

PERFORMANCE

Rated size
Min/max flow-rate
Max working pressure
Max setting pressure
Room temperature
Oil temperature
Recommended filtration
Tightening torque
Weight

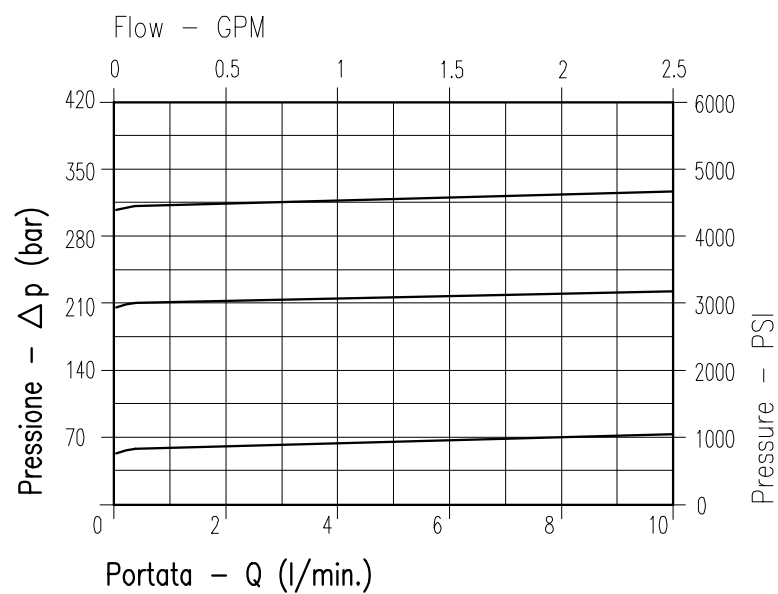

Viscosità olio 46 cSt a 50°C
Oil viscosity 46 cSt at 50°C

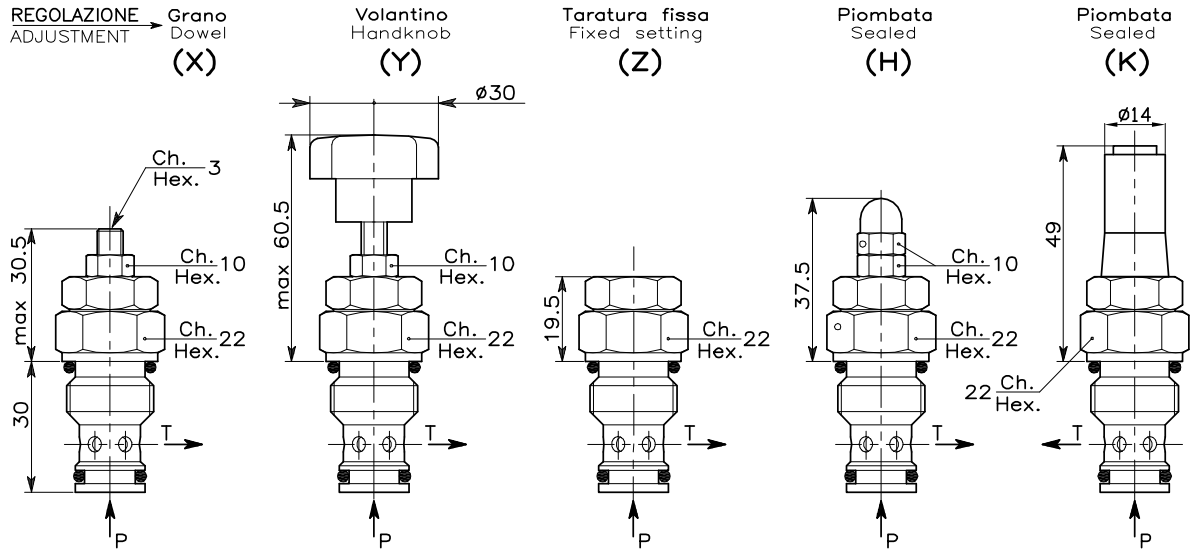

CAVITA' CAVITY CE.013.N

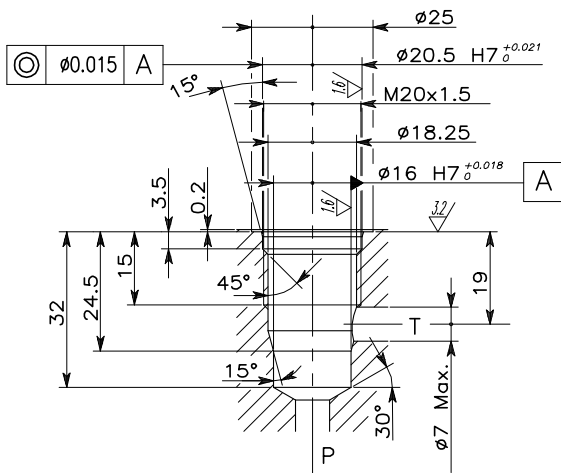

ESEMPIO TIPICO DI CIRCUITO TYPICAL CIRCUIT EXAMPLE

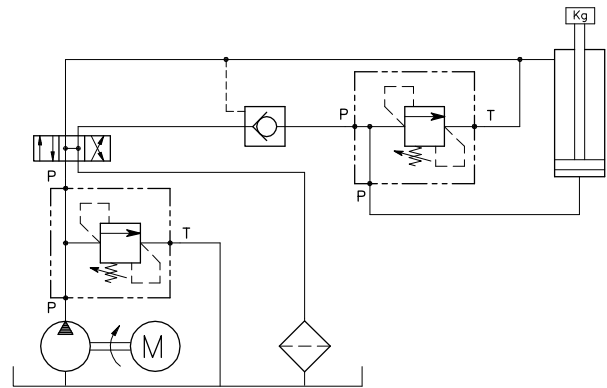

Si raccomanda l'esatta esecuzione della sede
The valve seat should be perfectly tooled

CODICE DI ORDINAZIONE HOW TO ORDER

002 099 0 X 0

Campo taratura / Setting range					
099		098		001	
Campo taratura 5÷100 bar (molla colore blu)		Campo taratura 10÷210 bar (molla colore verde)		Campo taratura 20÷350 bar (molla colore giallo)	
Setting range 5÷100 bar (blue spring)		Setting range 10÷210 bar (green spring)		Setting range 20÷350 bar (yellow spring)	
Taratura standard (Q=5 l/1')	Incr. press. - bar giro/vite	Taratura standard (Q=5 l/1')	Incr. press. - bar giro/vite	Taratura standard (Q=5 l/1')	Incr. press. - bar giro/vite
Std. bar setting (Q=5 l/1')	Pressure rise - turn of screw	Std. bar setting (Q=5 l/1')	Pressure rise - turn of screw	Std. bar setting (Q=5 l/1')	Pressure rise - turn of screw
70 bar	(--)	140 bar	(--)	280 bar	(--)

Regolazione Adjustment	
X	Grano - Dowel
Y	Volantino - Handknob
Z	Taratura fissa - Fixed setting
H	Piombata - Sealed
K	Piombata - Sealed