

VMP-35-CC-...

VALVOLA DI MASSIMA PRESSIONE A CARTUCCIA AD AZIONE DIRETTA CON OTTURATORE CONICO

CARTRIDGE RELIEF, DIRECT ACTING POPPET TYPE VALVE

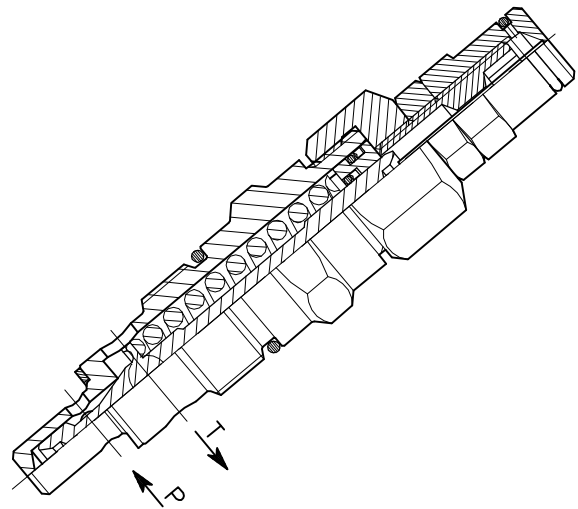
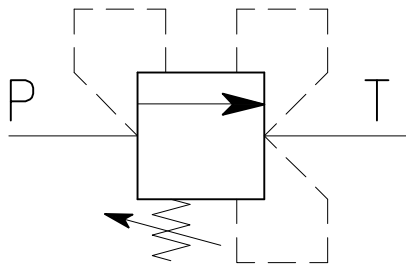

CARATTERISTICHE

Luce nominale	DN 8
Portata min/max	35 l/min - 9.2 GPM
Pressione di lavoro max.	350 bar - 5075 PSI
Pressione max. di taratura	350 bar - 5075 PSI
Temperatura ambiente	-30°C + 50°C
Temperatura olio	-30°C + 80°C
Filtraggio consigliato	30÷50 micron
Coppia di serraggio	50÷59 Nm
Peso	0.256 kg

PERFORMANCE

Rated size
Min/max flow-rate
Max working pressure
Max setting pressure
Room temperature
Oil temperature
Recommended filtration
Tightening torque
Weight

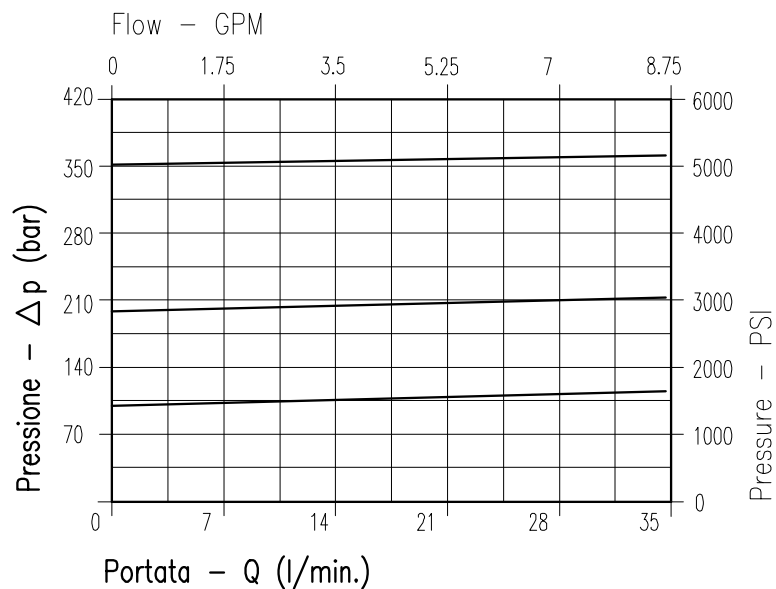

Viscosità olio 46 cSt a 50°C
Oil viscosity 46 cSt at 50°C

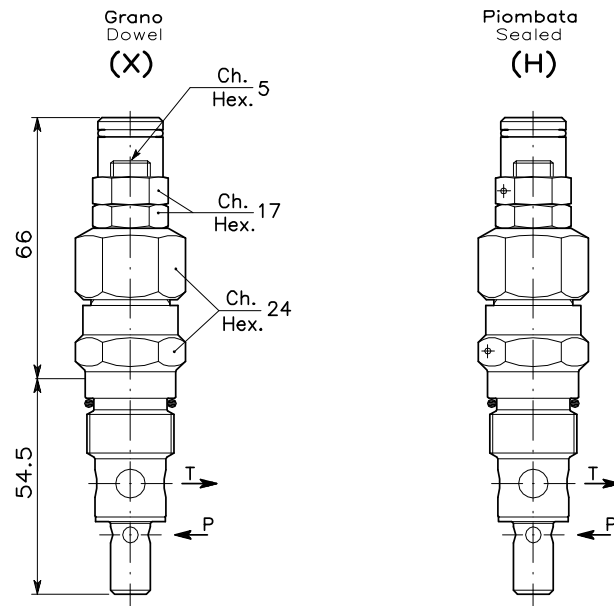
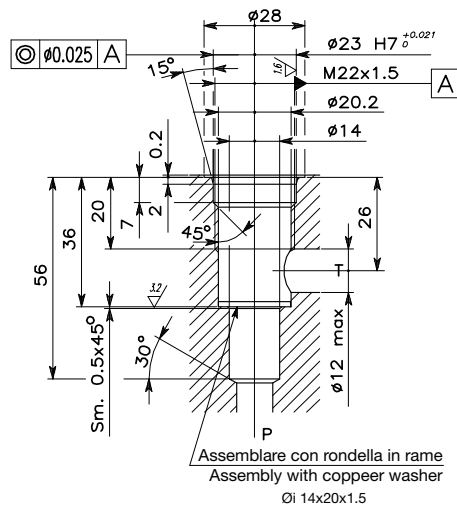
REGOLAZIONE
ADJUSTMENT

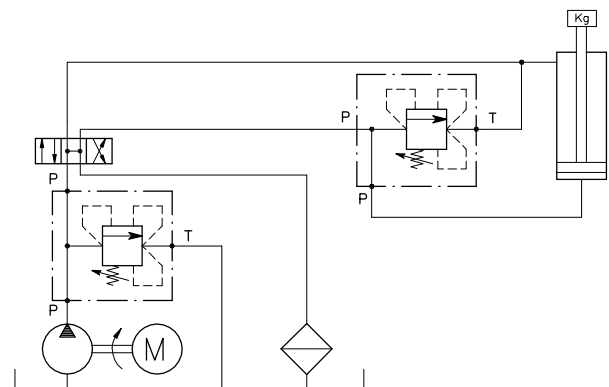
CAVITA' CAVITY CE.007.L

 Si raccomanda l'esatta esecuzione della sede
The valve seat should be perfectly tooled

ESEMPIO TIPICO DI CIRCUITO TYPICAL CIRCUIT EXAMPLE

CODICE DI ORDINAZIONE HOW TO ORDER

002 739 0 X 0

Campo taratura / Setting range					
739		740		741	
Campo taratura 5÷100 bar (molla colore blu)		Campo taratura 10÷210 bar (molla colore verde)		Campo taratura 20÷350 bar (molla colore giallo)	
Setting range 5÷100 bar (blue spring)		Setting range 10÷210 bar (green spring)		Setting range 20÷350 bar (yellow spring)	
Taratura standard (Q=5 l/1')	Incr. press. - bar giro/vite	Taratura standard (Q=5 l/1')	Incr. press. - bar giro/vite	Taratura standard (Q=5 l/1')	Incr. press. - bar giro/vite
Std. bar setting (Q=5 l/1')	Pressure rise - turn of screw	Std. bar setting (Q=5 l/1')	Pressure rise - turn of screw	Std. bar setting (Q=5 l/1')	Pressure rise - turn of screw
80 bar	(--)	180 bar	(--)	320 bar	(--)

Regolazione Adjustment	
X	Grano - Dowel
H	Piombata - Sealed