

VR-CRR-CTP5-12-34-34-...

PIASTRA DI BASE CETOP CON FUNZIONE RIGENERATIVA E VALVOLA DI MASSIMA

BASE PLATE ISO 5 VALVE WITH REGENERATIV FUNCTION AND RELIEF CARTRIDGE

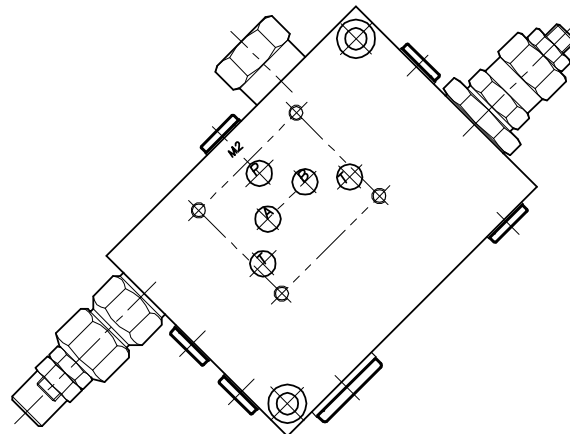
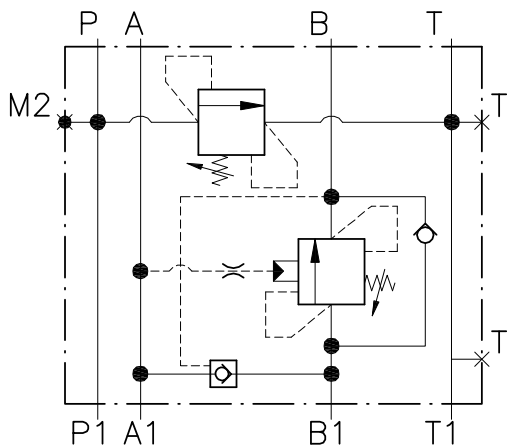

CARATTERISTICHE

Luce nominale	DN 10
Portata max in P	40 l/min - 10.5 GPM
Pressione di lavoro max.	350 bar - 5075 PSI
Pressione max. di taratura	350 bar - 5075 PSI
Temperatura ambiente	-30°C + 50°C
Temperatura olio	-30°C + 80°C
Filtraggio consigliato	30 micron
Peso	

PERFORMANCE

Rated size
Max flow in P port
Max working pressure
Max setting pressure
Room temperature
Oil temperature
Recommended filtration
Weight

NOTE:

La taratura deve essere **1.3** volte maggiore della pressione indotta dal carico.

Valve should be set at **1.3** times load induced pressure.

ESEMPIO/EXAMPLE:

Pressione di lavoro max:

Max working pressure:

350 bar / 1.3 = 270 bar

Base per elettrovalvole modulari ISO 5 con incorporata valvola di massima pressione con rigenerazione da B1 a A1, con esclusione automatica regolabile tramite valvola overcenter. Consente lo sfilamento rapido dello stelo di un cilindro differenziale.

Base plate for ISO 5 directional solenoid valves, including relief valve, with regenerative flow from B1 to A1, with adjustable automatic exclusion by an overcenter valve. Used for fast extension of cylinder rod.

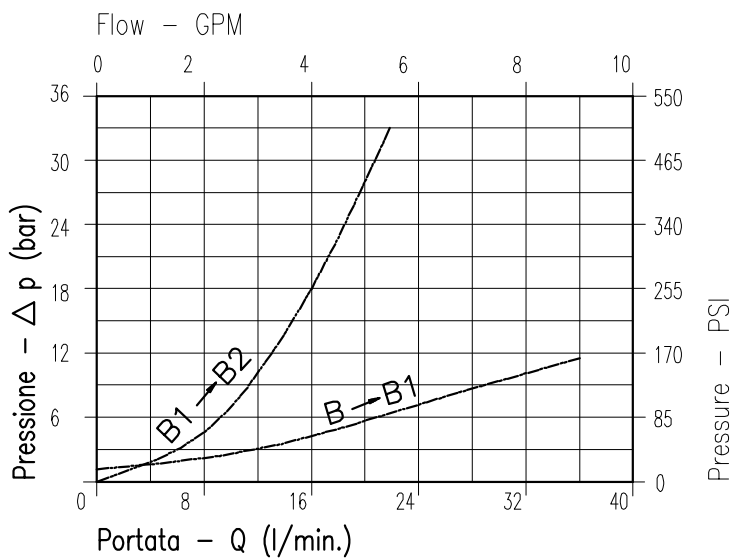

Viscosità olio 46 cSt a 50°C
Oil viscosity 46 cSt at 50°C

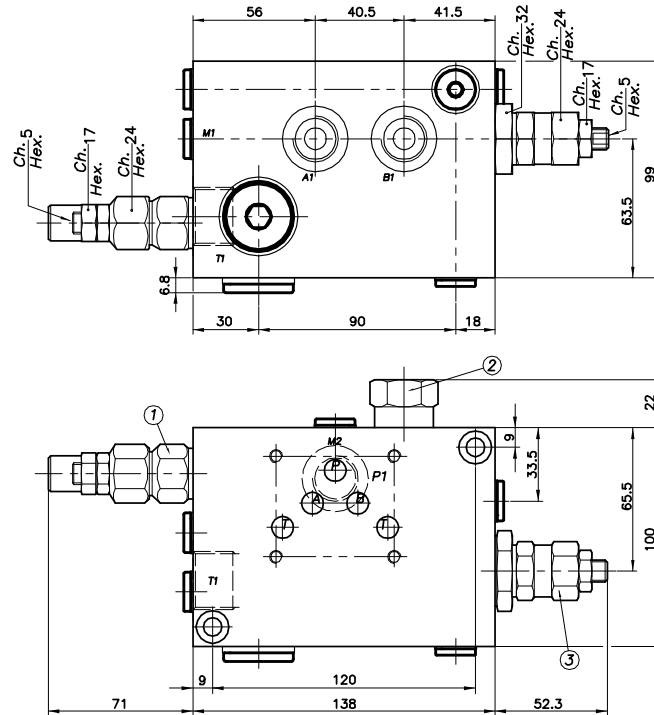

ESEMPIO TIPICO DI CIRCUITO TYPICAL CIRCUIT EXAMPLE

DIMENSIONI DIMENSIONS

Campo taratura Setting range	Attacchi filettati / Threaded connections Bocche - Ports ISO 1179-1 (BSPP)			Attacchi filettati Threaded connections Bocche - Ports ISO 4401 A-B / P-T size 10 (CETOP 5)
	M1-M2	A1-B1 P1	T1	
160	G1/4	G1/2	G3/4	

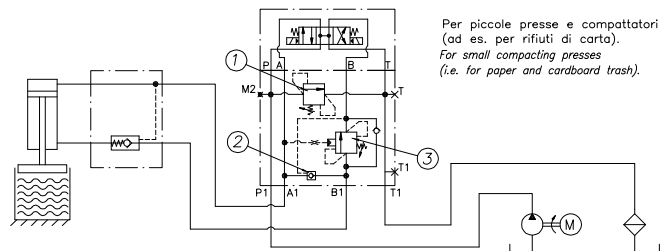

CODICE DI ORDINAZIONE HOW TO ORDER

006 160 0 X 0

Campo taratura / Setting range

160

Campo taratura 60÷350 bar (molla colore giallo)
Setting range 60÷350 bar (yellow spring)

Taratura standard (Q=5 l/1')
Std. bar setting (Q=5 l/1')
350 bar

Incr. press. - bar giro/vite
Pressure rise - bar/turn of scw
(138)

Rapporto di pilotaggio
Pilot ratios

O	4.25 : 1
B	3.2 : 1
C	1 : 2.1
D	8 : 1

Regolazione
Adjustment

X | Grano - Dowel